

PRODUCT SPECIFICATIONS

SHARP

AVC Liquid Crystal Displays Group

LQ121S1LG79

TFT-LCD Module

Spec. Issue Date: Mar. 11, 2011

No: LD-18123A

- Contents -

No.		page
1	Overview	1
2	Mechanical Specifications	1
3	Input Terminals	2
4	Absolute Maximum Ratings	8
5	Electrical Characteristics	9
6	Timing characteristics of input sig	11
7	Input Signals, Basic Display Colors and Gray Scale of Each Color ..	12
8	Optical Characteristics	14
9	Handling Precautions	16
10	Packing form	17
11	Reliability test items	17
12	Others	18
13	Storage conditions	18
Fig.1	Outline Dimensions	19
Fig.3	Packing form	20

1. Overview

This module is a color active matrix LCD module incorporating amorphous silicon TFT (Thin Film Transistor). It is composed of a color TFT-LCD panel, driver ICs, control circuit, power supply circuit and a White-LED Backlight unit. Graphics and texts can be displayed on a 800 × RGB × 600dots panel with about 1619 million colors by using LVDS (Low Voltage Differential Signaling) and supplying +3.3V DC supply voltages for TFT-LCD panel driving and +12.0V DC supply voltage for backlight.

The TFT-LCD panel used for this module is a high-brightness and high-contrast image.

The maximum viewing angle is in the 6o'clock direction.

The 12o'clock direction is difficult to reverse the grayscale.

The LED driver circuit and the PWM circuit to drive the backlight are built into the module.

2. Mechanical specifications

Parameter	specifications	Unit
Display size	30.7(12.1inch) Diagonal	cm
Active area	246.0(H) × 184.5(V)	mm
Pixel format	800(H) × 600(V) (1pixel=R+G+B dot)	pixel
Aspect ratio	4:3	
Pixel pitch	0.3075(H) × 0.3075(V)	mm
Pixel configuration	R,G,B vertical stripe	
Display mode	Normally white	
Unit outline dimensions	265.0(W) × 205.0(H) × 9.5(D)	mm
Mass	Max. 550	g
Surface treatment	Anti-glare and hard-coating 3H	

Outline dimensions are shown in Fig.1.

3. Input Terminals

3-1. TFT-LCD panel driving

CN1 (Interface signals and +3.3V power supply)

Using connectors: FI-XPB30SRL-HF11 (Japan Aviation Electronics industry Co., Ltd.)

Corresponding connectors:

FI-X30H / FI-X30HL / FI-X30C2-NPB (Japan Aviation Electronics industry Co., Ltd.)

Using LVDS receiver: Building into cotroll IC (THC63LVDF84B (Thine electronics) or Compatible product)

Corresponding LVDS transmitter: THC63LVDM83R (Thine electronics)

CN1

Pin	Symbol	Function	Remark
1	GND	GND	
2	SELLVDS	LVDS SET	【*1】
3	RL/UD	Horizontal/Vertical display mode select signal	【*2】
4	GND	GND	
5	RxIN3+	LVDS receiver signal CH3 (+)	LVDS
6	RxIN3-	LVDS receiver signal CH3 (-)	LVDS
7	GND	GND	
8	CK IN+	LVDS receiver signal CK (+)	LVDS
9	CK IN-	LVDS receiver signal CK (-)	LVDS
10	GND	GND	
11	RxIN2+	LVDS receiver signal CH2 (+)	LVDS
12	RxIN2-	LVDS receiver signal CH2 (-)	LVDS
13	GND	GND	
14	RxIN1+	LVDS receiver signal CH1 (+)	LVDS
15	RxIN1-	LVDS receiver signal CH1 (-)	LVDS
16	GND	GND	
17	RxIN0+	LVDS receiver signal CH0 (+)	LVDS
18	RxIN0-	LVDS receiver signal CH0 (-)	LVDS
19	GND	GND	
20	GND	GND	
21	VCC	+3.3V Power supply	
22	VCC	+3.3V Power supply	
23	GND	GND	
24	VBR	PWM signal	【*3】
25	XSTABY	Backlight ON/OFF signal	【*3】
26	GND	GND	
27	VDD	+12V Power supply	
28	VDD	+12V Power supply	
29	GND	GND	
30	GND	GND	

【*1】 SELLVDS is shown in 4-2.

【*2】 RL/UD = LOW

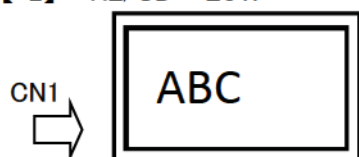

RL/UD = HIGH

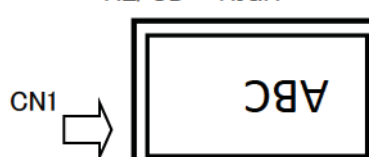

【*3】 shown in 6-2.

3-2. Data Mapping

1) 8 bit input

【*1】 pin assignment with SELLVDS pin (THC63LVDM83R(Thine electronics))

Transmitter		2Pin SELLVDS	
Pin No	Data	= L(GND) or Open	= H(3.3V)
51	TA0	R0 (LSB)	R2
52	TA1	R1	R3
54	TA2	R2	R4
55	TA3	R3	R5
56	TA4	R4	R6
3	TA5	R5	R7 (MSB)
4	TA6	G0 (LSB)	G2
6	TB0	G1	G3
7	TB1	G2	G4
11	TB2	G3	G5
12	TB3	G4	G6
14	TB4	G5	G7 (MSB)
15	TB5	B0 (LSB)	B2
19	TB6	B1	B3
20	TC0	B2	B4
22	TC1	B3	B5
23	TC2	B4	B6
24	TC3	B5	B7 (MSB)
27	TC4	(HS)	(HS)
28	TC5	(VS)	(VS)
30	TC6	DE	DE
50	TD0	R6	R0 (LSB)
2	TD1	R7 (MSB)	R1
8	TD2	G6	G0 (LSB)
10	TD3	G7 (MSB)	G1
16	TD4	B6	B0 (LSB)
18	TD5	B7 (MSB)	B1
25	TD6	(NA)	(NA)

< SELLVDS = L(GND) or Open >

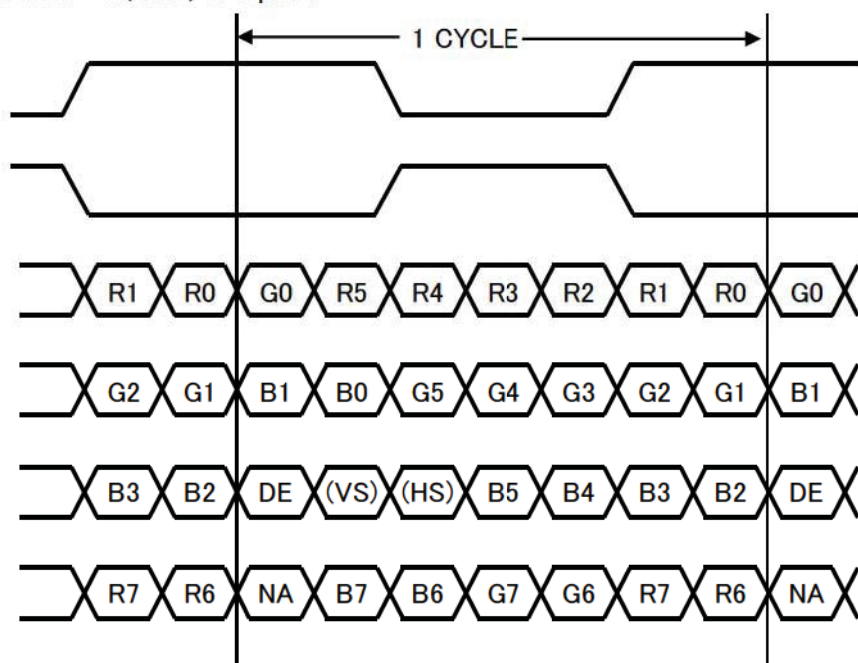

< SELLVDS = H(3.3V) >

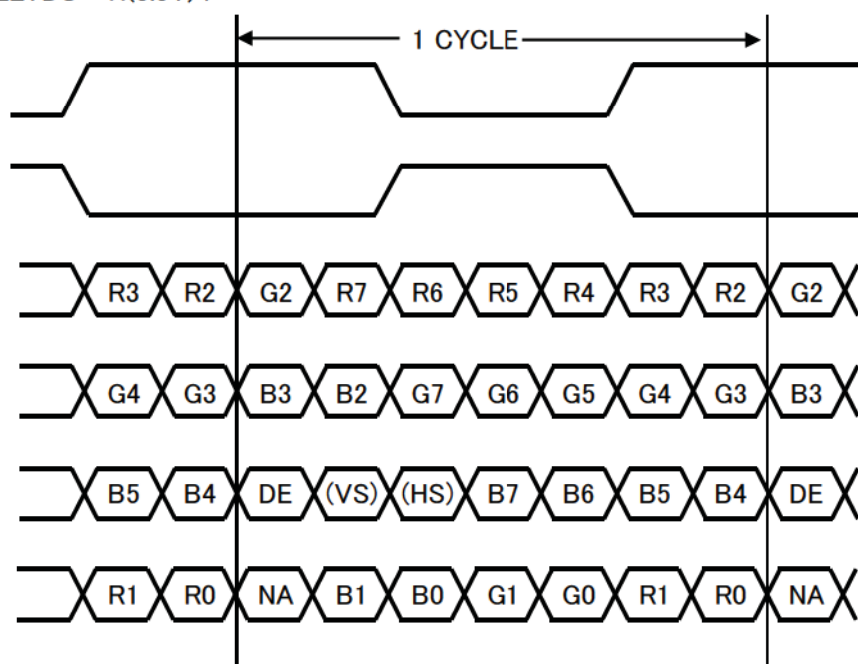

DE: DATA ENABLE

HS: Hsync

VS: Vsync

2) 6bit input

【*1】 pin assignment with SELLVDS (THC63LVDM83R(Thine electronics))

Transmitter		2Pin SELLVDS	
Pin No	Data	= L(GND) or Open	= H(3.3V)
51	TA0	-	R0 (LSB)
52	TA1	-	R1
54	TA2	-	R2
55	TA3	-	R3
56	TA4	-	R4
3	TA5	-	R5 (MSB)
4	TA6	-	G0 (LSB)
6	TB0	-	G1
7	TB1	-	G2
11	TB2	-	G3
12	TB3	-	G4
14	TB4	-	G5 (MSB)
15	TB5	-	B0 (LSB)
19	TB6	-	B1
20	TC0	-	B2
22	TC1	-	B3
23	TC2	-	B4
24	TC3	-	B5 (MSB)
27	TC4	-	(HS)
28	TC5	-	(VS)
30	TC6	-	DE
50	TD0	-	GND
2	TD1	-	GND
8	TD2	-	GND
10	TD3	-	GND
16	TD4	-	GND
18	TD5	-	GND
25	TD6	-	(NA)

< SELLVDS = H(3.3V) >

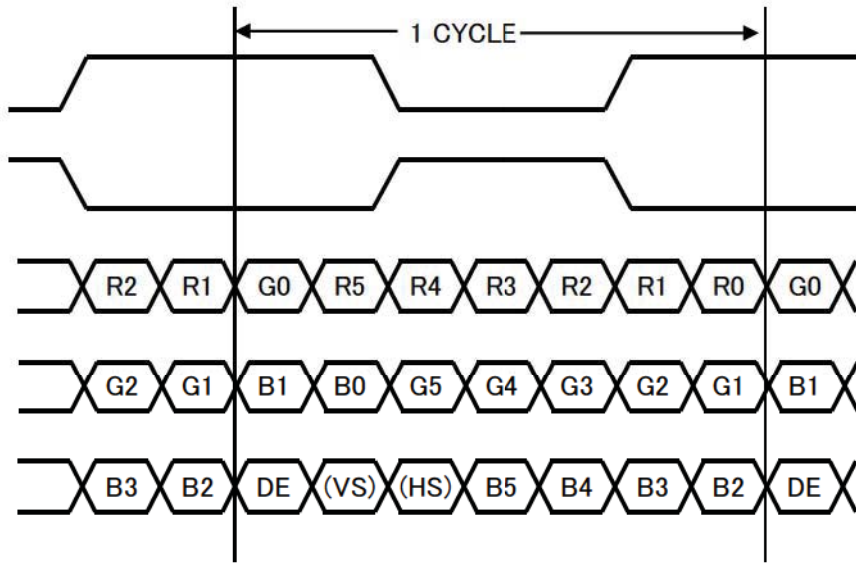

DE: DATA ENABLE

HS: Hsync

VS: Vsync

3-3. Interface block diagram

① 8 bit input (Computer Side)
SELLVDS = L(GND) or Open

(TFT-LCD side)

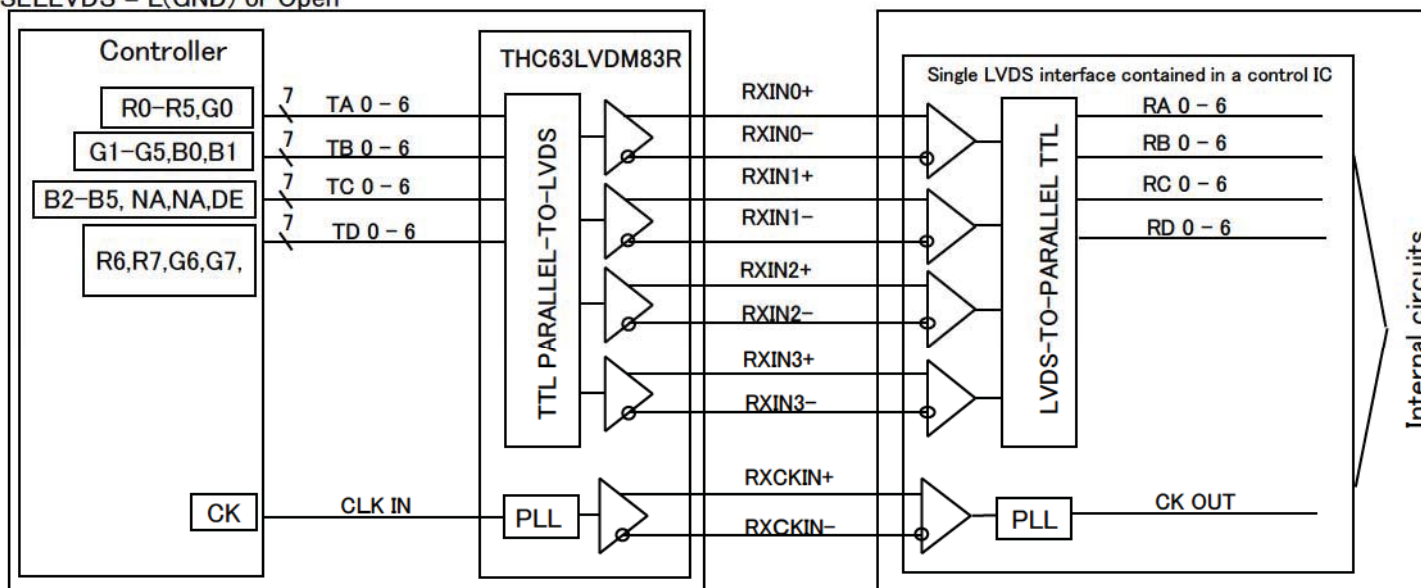

② 8 bit input
SELLVDS = H(3.3V)

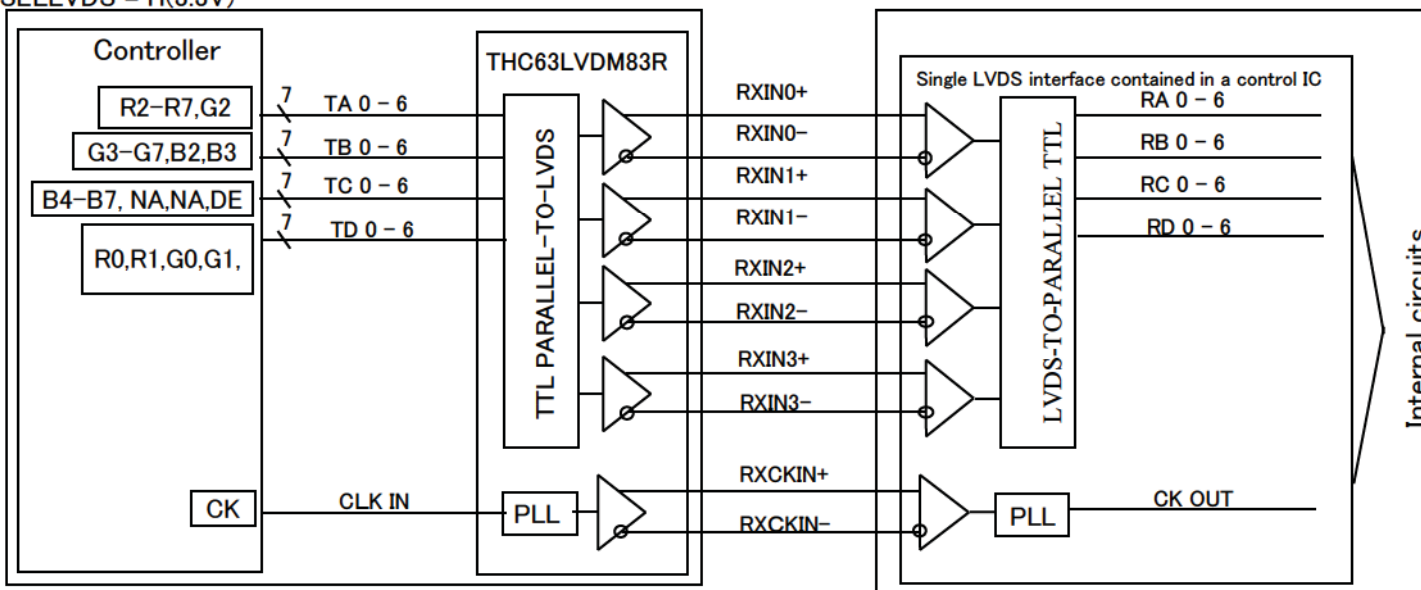

③ 6 bit input
SELLVDS = H(3.3V)

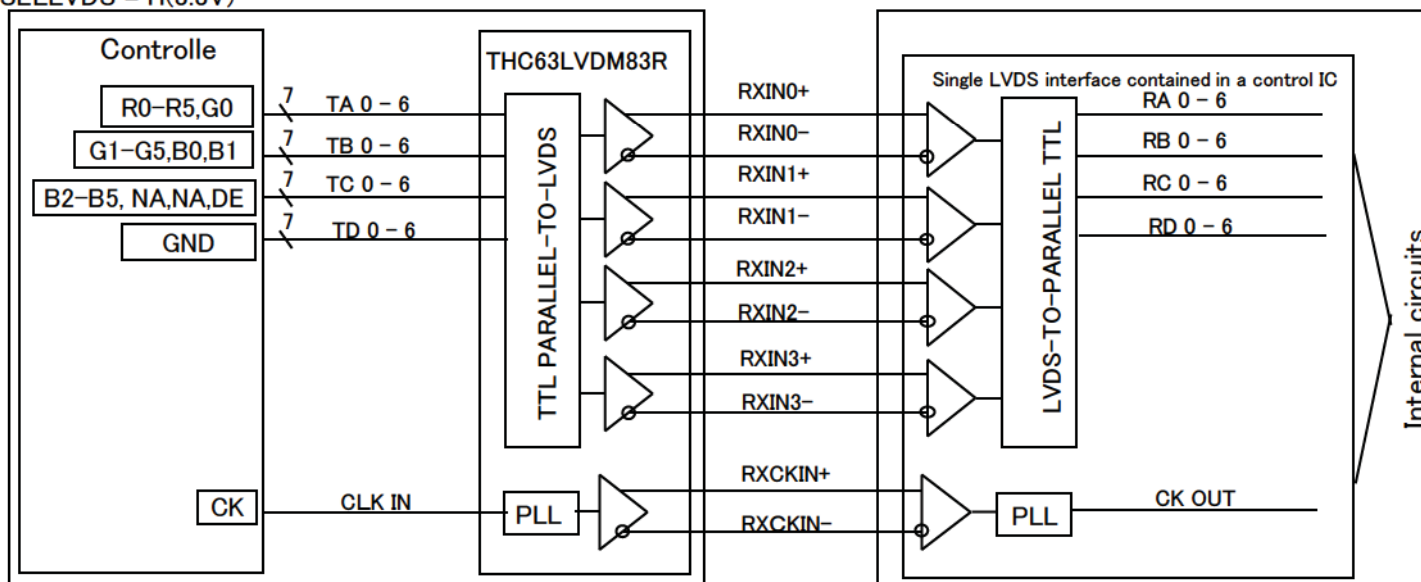

4. Absolute Maximum Ratings

Parameter	Symbol	Condition	Pin	Ratings	Unit	Remark
Supply voltage	V _{CC}	T _a =25°C	VCC	-0.3 ~ +4.0	V	【*1,2】
	V _{DD}	T _a =25°C	VDD	-0.3 ~ +15.0	V	【*1,2】
Input voltage	V _{I1}	T _a =25°C	RxINi-/+ CK IN-/+	-0.3~V _{CC} +0.3	V	i=0,1,2,3
	V _{I2}	T _a =25°C	RL/UD,SELLVDS	-0.3~V _{CC} +0.3	V	
	V _{I4}	T _a =25°C	XSTABY, VBR	-0.3~+VDD	V	
Storage temperature	T _{STG}	—	-	-30 ~ +75	°C	【*1】
Operating temperature	T _{OPA}	—	-	-10 ~ +75	°C	【*1,3,4】

【*1】 Humidity: 95%RH Max.(T_a ≤ 40°C) Note static electricity.

Maximum wet-bulb temperature at 39°C or less. (T_a > 40°C) No condensation.

【*2】 The V_{CC} power supply capacity must use the one of 2A or more.

The V_{CC} power supply capacity must use the one of 3A or more.

【*3】 There is a possibility of causing deterioration in the irregularity and others of the screen and the display fineness though the liquid crystal module doesn't arrive at destruction when using it at 65~75°C.

【*4】 In the operating temperature item, the low temperature side is the ambient temperature regulations.
The high temperature side is the panel surface temperature regulations.

5. Electrical Characteristics

5-1. TFT-LCD panel driving

 $T_a = +25^\circ\text{C}$

Parameter	Symbol	Condition	Min.	Typ.	Max.	Unit	Remark
Supply voltage	V_{CC}		3.0	3.3	3.6	V	【*1】
Current dissipation	I_{CC}	$V_{CC}=3.3\text{V}$	—	260	390	mA	【*2】
Input voltage width for LVDS receiver	V_L		0	—	2.4	V	
Permissible input ripple voltage	V_{RP}		—	—	200	mV _{P-P}	$V_{CC}=3.3\text{V}$
Differential input Threshold voltage	High	V_{TH}	—	—	$V_{CM}+100$	mV	$V_{CM} = +1.2\text{V}$ 【*3】
	Low	V_{TL}	$V_{CM}-100$	—	—	mV	
Input voltage	V_{IH}		2.1	—	—	V	【*4】
	V_{IL}		—	—	0.8	V	
Input leak current	I_{OH}		—	—	400	μA	$V_{I2} = +3.3\text{V}$ 【*4】
	I_{OL}		-10	—	+10	μA	$V_{I2} = 0\text{V}$ 【*4】
Terminal resistor	R_T		—	100	—	Ω	Differential input

【*1】 On-off conditions for supply voltage

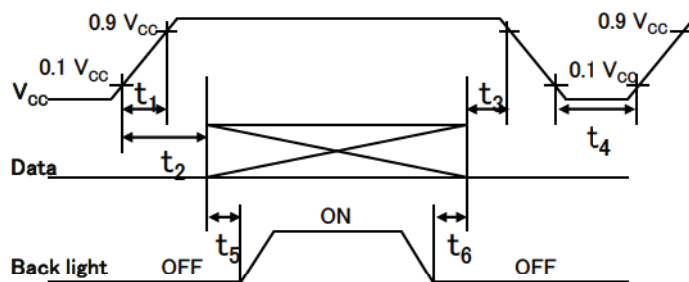

$$0 < t_1 \leq 10\text{ms}$$

$$0 < t_2 \leq 20\text{ms}$$

$$0 < t_3 \leq 1\text{s}$$

$$1\text{s} \leq t_4$$

$$500\text{ms} \leq t_5$$

$$200\text{ms} \leq t_6$$

Vcc-dip conditions

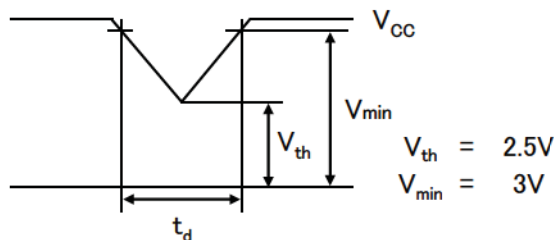

- $V_{th} < V_{CC} \leq V_{min}$
 $t_d \leq 10\text{ms}$
- $V_{CC} < V_{th}$

Vcc-dip conditions should also follow the On-off conditions for supply voltage

- Hsync/Vsync need not be input so that this model may drive only by the ENAB signal. Even if Hsync/Vsync is input, it doesn't become a malfunction.
- The relation between the data input and the backlight lighting will recommend the above-mentioned input sequence. When the backlight is turned on before the panel operates, there is a possibility of abnormally displaying. The liquid crystal module is not damaged.

【*2】 Current dissipation

Typical current situation : 253-gray-bar pattern

(Measurement condition : $V_{CC}=+3.3\text{V}$, $f_{ck}=40\text{MHz}$, $T_a=25^\circ\text{C}$)

Regarding RGB gradation, refer to Chapter 8

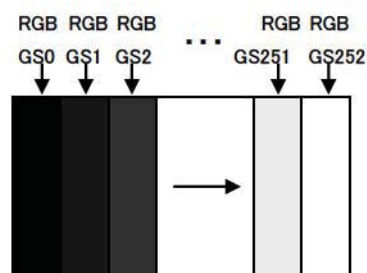

【注3】 V_{CM} : LVDS common mode voltage

【注4】 RL/UD , SELLVDS

5-2. LED backlight

Ta=+25°C

Parameter	Symbol	Min.	Typ.	Max.	Unit	Remark
Supply voltage	V _{DD}	10.2	12.0	13.8	V	【*1】
Current dissipation	I _{DD1}	-	350	500	mA	【*2】
	I _{DD2}	-	-	10	μ A	【*3,4】
Permissible input ripple voltage	V _{RP_BL}	-	-	200	mVP-P	V _{DD} =+12.0V
BL1 input high voltage	V _{IH_BL1}	2.4	-	V _{DD}	V	【*3】
BL1 input Low voltage	V _{IL_BL1}	-	-	0.2	V	【*3】
BL2 input high voltage	V _{IH_BL2}	2.1	-	V _{DD}	V	【*4】
BL2 input low voltage	V _{IL_BL2}	-	-	0.8	V	【*4】
PWM frequency	f _{PWM}	200	-	1K	Hz	【*4,5】
PWM duty	D _{PWM}	50	-	100	%	【*4,5】
Life time	L	-	(50,000) (Module)	-	h	【Reference】 【*6】

【*1】 On-off conditions for supply voltage

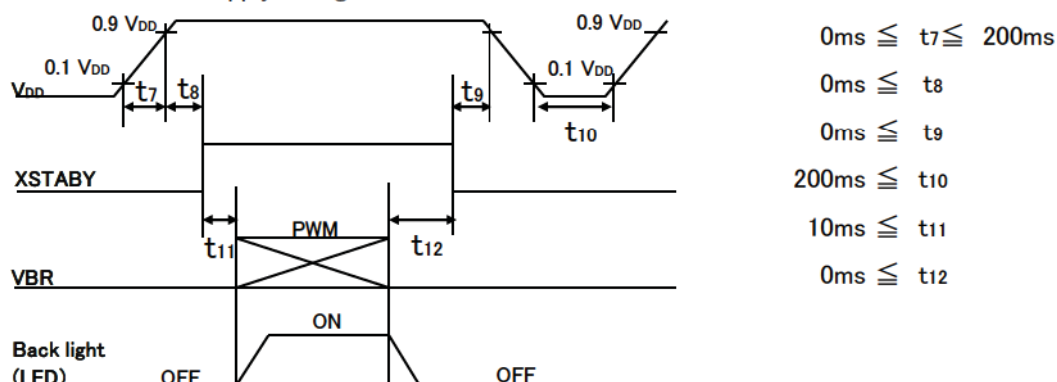

【*2】 Current dissipation

Typ. value: V_{DD}=+12.0V、Duty=100%

Max. value: V_{DD}=+10.2V、Duty=100%

【*3】 XSTABY

【*4】 VBR

【*5】 PWM

f_{PWM} = 1/t₁₄

Duty 0% : Min. Luminance

Duty 100% : Max. Luminance

Luminance changes in proportion to the duty ratio. (t₁₃ ≥ 10μ s)

When the frequency slows, the display fineness might decrease.

PWM frequency may interfere with drive frequency and generate wavy noise on the display.

To avoid this symptom, please keep PWM frequency as different frequency from drive frequency and its harmonic frequency as possible while using.

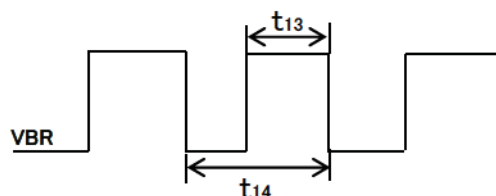

【*6】 Luminance becomes 50% of an initial value. (Ta=25°C, PWM=100%)

6. Timing characteristics of input signals

6-1. Timing characteristics

Parameter	Symbol	Min.	Typ.	Max.	Unit	Remark	
Clock	Frequency	1/Tc	35	40	42	MHz	
ENAB	Horizontal period	TH	940	1056	1395	clock	【*1】
			23.5	26.4	39.9	μs	
	Horizontal period (High)	THd	800	800	800	clock	
	Vertical Frequency	TV	628	666	798	line	
			-	16.7	-	ms	
Vertical period (High)	TVd	600	600	600	line		

【*1】 In case of using the long vertical period, the deterioration of display quality, flicker etc. may occur.

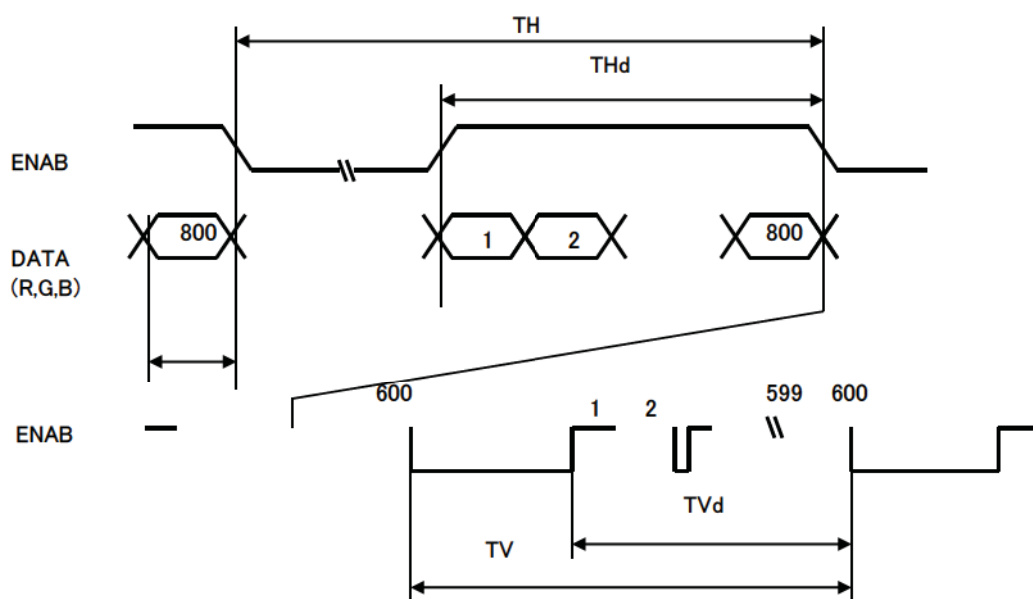

6-2. Input Data Signals and Display Position on the screen

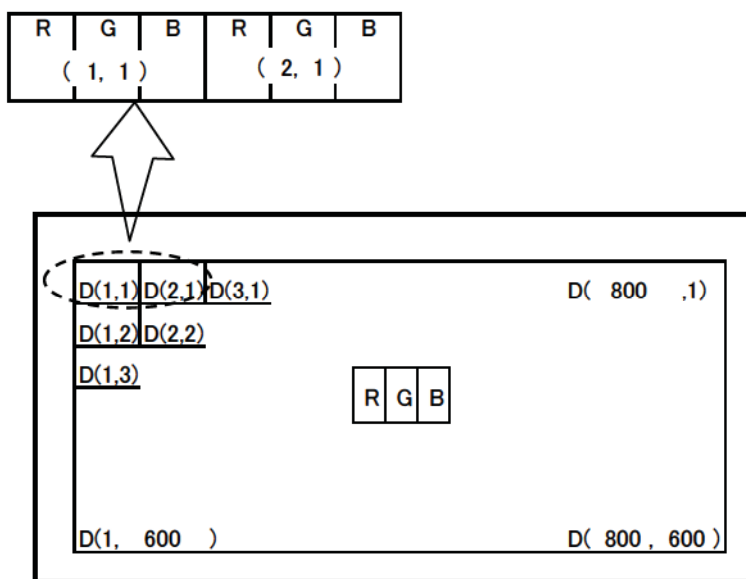

7. Input Signals, Basic Display Colors and Gray Scale of Each Color

7-1. 8 bit input

	Colors & Gray scale	Data signal																								
		Gray Scale	R0	R1	R2	R3	R4	R5	R6	R7	G0	G1	G2	G3	G4	G5	G6	G7	B0	B1	B2	B3	B4	B5	B6	B7
Basic Color	Black	—	0	0	0	0	0	0	0	0	0	0	0	0	0	0	0	0	0	0	0	0	0	0	0	0
	Blue	—	0	0	0	0	0	0	0	0	0	0	0	0	0	0	0	0	X	X	1	1	1	1	1	1
	Green	—	0	0	0	0	0	0	0	0	X	X	1	1	1	1	1	1	0	0	0	0	0	0	0	0
	Cyan	—	0	0	0	0	0	0	0	0	X	X	1	1	1	1	1	1	X	X	1	1	1	1	1	1
	Red	—	X	X	1	1	1	1	1	1	0	0	0	0	0	0	0	0	0	0	0	0	0	0	0	0
	Magenta	—	X	X	1	1	1	1	1	1	0	0	0	0	0	0	0	0	X	X	1	1	1	1	1	1
	Yellow	—	X	X	1	1	1	1	1	1	X	X	1	1	1	1	1	1	0	0	0	0	0	0	0	0
	White	—	X	X	1	1	1	1	1	1	X	X	1	1	1	1	1	1	X	X	1	1	1	1	1	1
Gray Scale of Red	Black	GS0	0	0	0	0	0	0	0	0	0	0	0	0	0	0	0	0	0	0	0	0	0	0	0	0
	↑	GS1	1	0	0	0	0	0	0	0	0	0	0	0	0	0	0	0	0	0	0	0	0	0	0	0
	Darker	GS2	0	1	0	0	0	0	0	0	0	0	0	0	0	0	0	0	0	0	0	0	0	0	0	0
	↑	↑	↑							↑							↑									
	↓	↓	↓							↓							↓									
	Brighter	GS250	1	0	0	1	1	1	1	1	0	0	0	0	0	0	0	0	0	0	0	0	0	0	0	0
	↓	GS251	1	1	0	1	1	1	1	1	0	0	0	0	0	0	0	0	0	0	0	0	0	0	0	0
Red	GS252	X	X	1	1	1	1	1	1	0	0	0	0	0	0	0	0	0	0	0	0	0	0	0	0	
Gray Scale of Green	Black	GS0	0	0	0	0	0	0	0	0	0	0	0	0	0	0	0	0	0	0	0	0	0	0	0	0
	↑	GS1	0	0	0	0	0	0	0	0	1	0	0	0	0	0	0	0	0	0	0	0	0	0	0	0
	Darker	GS2	0	0	0	0	0	0	0	0	0	1	0	0	0	0	0	0	0	0	0	0	0	0	0	0
	↑	↑	↑							↑							↑									
	↓	↓	↓							↓							↓									
	Brighter	GS250	0	0	0	0	0	0	0	0	1	0	0	1	1	1	1	1	0	0	0	0	0	0	0	0
	↓	GS251	0	0	0	0	0	0	0	0	1	1	0	1	1	1	1	1	0	0	0	0	0	0	0	0
Green	GS252	0	0	0	0	0	0	0	0	X	X	1	1	1	1	1	1	0	0	0	0	0	0	0	0	
Gray Scale of Blue	Black	GS0	0	0	0	0	0	0	0	0	0	0	0	0	0	0	0	0	0	0	0	0	0	0	0	0
	↑	GS1	0	0	0	0	0	0	0	0	0	0	0	0	0	0	0	0	1	0	0	0	0	0	0	0
	Darker	GS2	0	0	0	0	0	0	0	0	0	0	0	0	0	0	0	0	0	1	0	0	0	0	0	0
	↑	↑	↑							↑							↑									
	↓	↓	↓							↓							↓									
	Brighter	GS250	0	0	0	0	0	0	0	0	0	0	0	0	0	0	0	0	1	0	0	1	1	1	1	1
	↓	GS251	0	0	0	0	0	0	0	0	0	0	0	0	0	0	0	0	1	1	0	1	1	1	1	1
Blue	GS252	0	0	0	0	0	0	0	0	0	0	0	0	0	0	0	0	X	X	1	1	1	1	1	1	

0 :Low level voltage 1 :High level voltage X :Don't care

Each basic color can be displayed in 253 gray scales from 8 bit data signals. According to the combination of total 24 bit data signals, the 16-million-color display can be achieved on the screen.

7-2. 6 bit input

	Colors & Gray scale	Data signal																		
		GrayScale	R0	R1	R2	R3	R4	R5	G0	G1	G2	G3	G4	G5	B0	B1	B2	B3	B4	B5
Basic Color	Black	—	0	0	0	0	0	0	0	0	0	0	0	0	0	0	0	0	0	0
	Blue	—	0	0	0	0	0	0	0	0	0	0	0	0	1	1	1	1	1	1
	Green	—	0	0	0	0	0	0	1	1	1	1	1	1	0	0	0	0	0	0
	Cyan	—	0	0	0	0	0	0	1	1	1	1	1	1	1	1	1	1	1	1
	Red	—	1	1	1	1	1	1	0	0	0	0	0	0	0	0	0	0	0	0
	Magenta	—	1	1	1	1	1	1	0	0	0	0	0	0	1	1	1	1	1	1
	Yellow	—	1	1	1	1	1	1	1	1	1	1	1	1	0	0	0	0	0	0
	White	—	1	1	1	1	1	1	1	1	1	1	1	1	1	1	1	1	1	1
Gray Scale of Red	Black	GS0	0	0	0	0	0	0	0	0	0	0	0	0	0	0	0	0	0	0
	↑	GS1	1	0	0	0	0	0	0	0	0	0	0	0	0	0	0	0	0	0
	Darker	GS2	0	1	0	0	0	0	0	0	0	0	0	0	0	0	0	0	0	0
	↑	↓	↓			↓			↓			↓								
	↓	↓	↓			↓			↓			↓								
	Brighter	GS61	1	0	1	1	1	1	0	0	0	0	0	0	0	0	0	0	0	0
	↓	GS62	0	1	1	1	1	1	0	0	0	0	0	0	0	0	0	0	0	0
	Red	GS63	1	1	1	1	1	1	0	0	0	0	0	0	0	0	0	0	0	0
Gray Scale of Green	Black	GS0	0	0	0	0	0	0	0	0	0	0	0	0	0	0	0	0	0	0
	↑	GS1	0	0	0	0	0	0	1	0	0	0	0	0	0	0	0	0	0	0
	Darker	GS2	0	0	0	0	0	0	0	1	0	0	0	0	0	0	0	0	0	0
	↑	↓	↓			↓			↓			↓								
	↓	↓	↓			↓			↓			↓								
	Brighter	GS61	0	0	0	0	0	0	1	0	1	1	1	1	0	0	0	0	0	0
	↓	GS62	0	0	0	0	0	0	0	1	1	1	1	1	0	0	0	0	0	0
	Green	GS63	0	0	0	0	0	0	1	1	1	1	1	1	0	0	0	0	0	0
Gray Scale of Blue	Black	GS0	0	0	0	0	0	0	0	0	0	0	0	0	0	0	0	0	0	0
	↑	GS1	0	0	0	0	0	0	0	0	0	0	0	0	1	0	0	0	0	0
	Darker	GS2	0	0	0	0	0	0	0	0	0	0	0	0	0	1	0	0	0	0
	↑	↓	↓			↓			↓			↓								
	↓	↓	↓			↓			↓			↓								
	Brighter	GS61	0	0	0	0	0	0	0	0	0	0	0	0	1	0	1	1	1	1
	↓	GS62	0	0	0	0	0	0	0	0	0	0	0	0	0	1	1	1	1	1
	Blue	GS63	0	0	0	0	0	0	0	0	0	0	0	0	1	1	1	1	1	1

Each basic color can be displayed in 64 gray scales from 6 bit data signals. According to the combination of total 18 bit data signals, the 262,144-color display can be achieved on the screen.

8. Optical Characteristics

Ta=+25°C, Vcc=+3.3V

Parameter		Symbol	Condition	Min.	Typ.	Max.	Unit	Remark	
Viewing angle range	Horizontal	θ_{21}, θ_{22}	CR>10	60	80	-	Deg.	【*1,2,4】	
	Vertical	θ_{11}		35	60	-	Deg.		
		θ_{12}		60	80	-	Deg.		
Contrast ratio		CR	optimized angle	500	800	-		【*2,4】	
Response Time	White Black	$\tau_r + \tau_d$	$\theta = 0^\circ$	-	30	-	ms	【*3,4】	
Chromaticity of White	Wx			0.240	0.290	0.340		【*4】	
	Wy			0.255	0.305	0.355			
Chromaticity of Red	Rx				0.650				
	Ry				0.330				
Chromaticity of Green	Gx				0.310				
	Gy				0.640				
Chromaticity of Blue	Bx				0.150				
	By				0.060				
Luminance of white		Y_{L1}			260	330	-		cd/m ²
White Uniformity				-	-	1.33			【*5】

※The measurement shall be executed 30 minutes after lighting at rating.

The optical characteristics shall be measured in a dark room or equivalent state with the method shown in Fig.2 below.

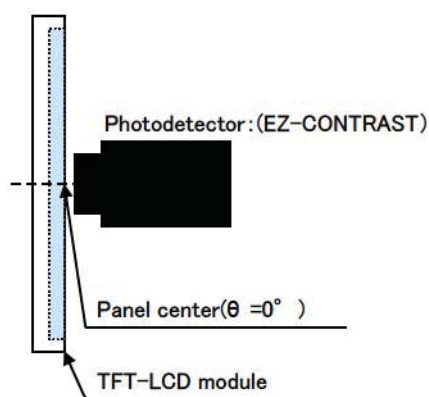

fig.2-1 Measuring method of Viewing angle range.

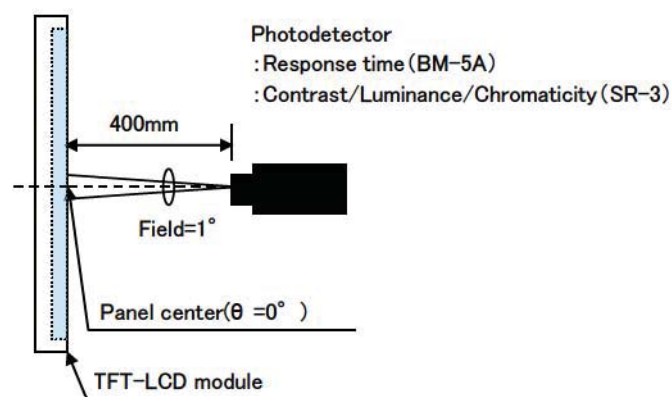
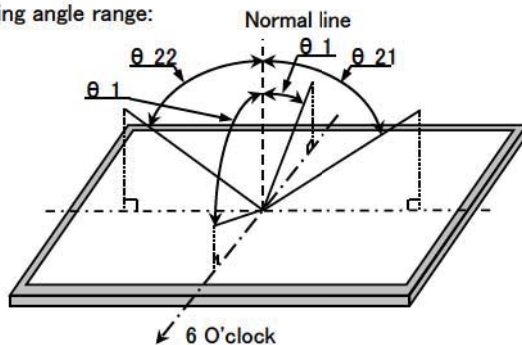

fig.2-2 Measuring method of contrast, luminance, response time, and Chromaticity.

Fig.2 Optical characteristics measurement method

【*1】Definitions of viewing angle range:



【*2】Definition of contrast ratio:

The contrast ratio is defined as the following.
$$\text{Contrast (CR)} = \frac{\text{Luminance with all pixels white}}{\text{Luminance with all pixels black}}$$

【*3】Definition of response time:

The response time is defined as the following figure and shall be measured by switching the input signal for "black" and "white".

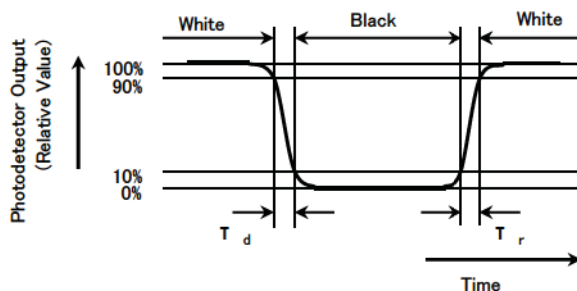

【*4】This shall be measured at center of the screen.

【*5】Definition of white uniformity:

White uniformity is defined as the following with five measurements. (①~⑤)

$$\delta_w = \frac{\text{Maximum luminance of 5 points(①~⑤)}}{\text{Maximum luminance of 5 points(①~⑤)}}$$

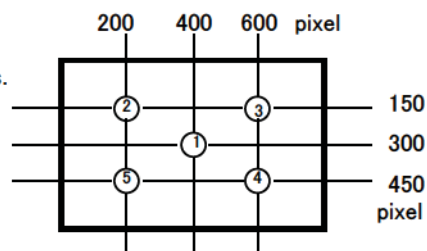

9. Handling Precautions

- a) Be sure to turn off the power supply when inserting or disconnecting the cable.
- b) Since the front polarizer is easily damaged, pay attention not to scratch it.
- c) Wipe off water drop immediately. Long contact with water may cause discoloration or spots.
- d) When the panel surface is soiled, wipe it with absorbent cotton or other soft cloth.
- e) Since the panel is made of glass, it may break or crack if dropped or bumped on hard surface.
Handle with care.
- f) Since CMOS LSI is used in this module, take care of static electricity and injure the human earth when handling. Observe all other precautionary requirements in handling components.
- g) Since there is a circuit board in the module back, stress is not added at the time of a design assembly.
Please make it like. If stress is added, there is a possibility that circuit parts may be damaged.
- h) It causes an irregular display and the defective indication, etc., when always put constant pressure on the back of the module.
Please do not make the structure to press the back of the module.
- i) Do not expose the LCD panel to direct sunlight. Lightproof shade etc. should be attached when LCD panel is used under such environment.
- j) Connect GND to stabilize against EMI and external noise.
- k) When handling LCD modules and assembling them into cabinets, please avoid that long-terms storage in the environment of oxidization or deoxidization gas and the use of such materials as reagent, solvent, adhesive, resin, etc. which generate these gasses, may cause corrosion and discoloration of the modules.
Do not use the LCD module under such environment.
- l) Please do not pull, and do not hang LED_FPC at the installation of the module.
- m) Liquid crystal contained in the panel may leak if the LCD is broken. Rinse it as soon as possible if it gets inside your eye or mouth by mistake.
- n) Be careful when using it for long time with fixed pattern display as it may cause accidental image.
- o) Adjusting volume have been set optimally before shipment, so do not change any adjusted value.
If adjusted value is changed, the specification may not be satisfied.
- p) If a minute particle enters in the module and adheres to an optical material, it may cause display non-uniformity issue, etc. Therefore, fine-pitch filters have to be installed to cooling and inhalation hole if you intend to install a fan.
- q) The polarizer surface on the panel is treated with Anti-Glare for low reflection. In case of attaching protective board over the LCD, be careful about the optical interface fringe etc. which degrades display quality.
- r) Notice : Never take to pieces the module , because it will cause failure.
Please do not peel off the Black tape pasted to the product.
- s) An abnormal display by changing in quality of the polarizing plate might occur regardless of contact or no contact to the polarizing plate, because of epoxy resin (amine system curing agent) that comes out from the material and the packaging material used for the set side, the silicon adhesive (dealcoholization system and oxime system), and the tray blowing agents (azo-compound), etc.
Please confirm adaptability with your employed material.

2010.06.16

裏面図

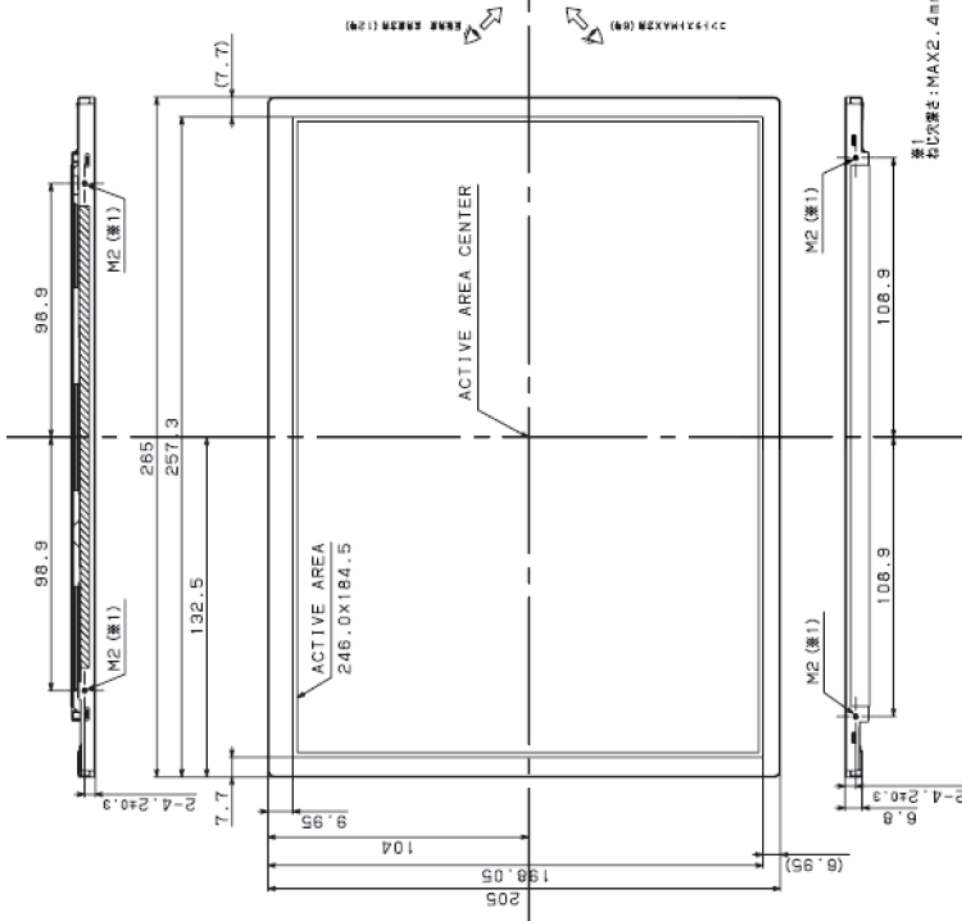

I/Fコネクタ
CN1:ピンレイアウト

pin	1	2	3	4	5	6	7
	GND	SELLVDS	RL/UD	GND	Rx[IN3+]	Rx[IN3-]	GND
8	9	10	11	12	13	14	15
CK [IN+]	CK [IN-]	GND	Rx[IN2+]	Rx[IN2-]	GND	Rx[IN1+]	Rx[IN1-]
16	17	18	19	20	21	22	23
GND	Rx[IN0+]	Rx[IN0-]	GND	GND	VCC	VCC	GND
24	25	26	27	28	29	30	
VER	XSTABY	GND	VDD	VDD	GND	GND	

ベゼル/画面位置詳細

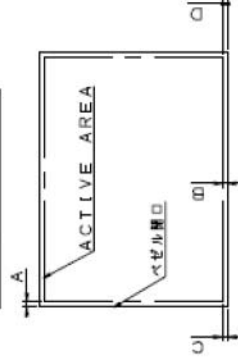

- 1) X方向の公差 A: 1.8±0.8
- 2) Y方向の公差 B: 1.8±0.8
- 3) 画面の傾き |C-D| < 0.8

NOTES

- 1) 一般公差±0.5
 - 2) 裏面カバーをはきおしLED_FPC部はモジュール厚みとはから除く
 - 3) 裏面カバーの掛かっている箇所は導電性を接触させないよう注意します。
 - 4) ハッチングしている箇所はテープ類は剥がさないで下さい。
 - 5) ユーザー取り付け時の推奨トルク値 (4ヶ所)
0.147±0.02N・m (1.5±0.2kgf・cm)
- 注: 実機にてネジの締め・外れ等の問題が無い場合、確認下さい。

適合コネクタ: FI-X30H/FI-X30HL/FI-X30C2-NPB (航空電子工業会) 又は同等仕物品

図1: モジュール外形図

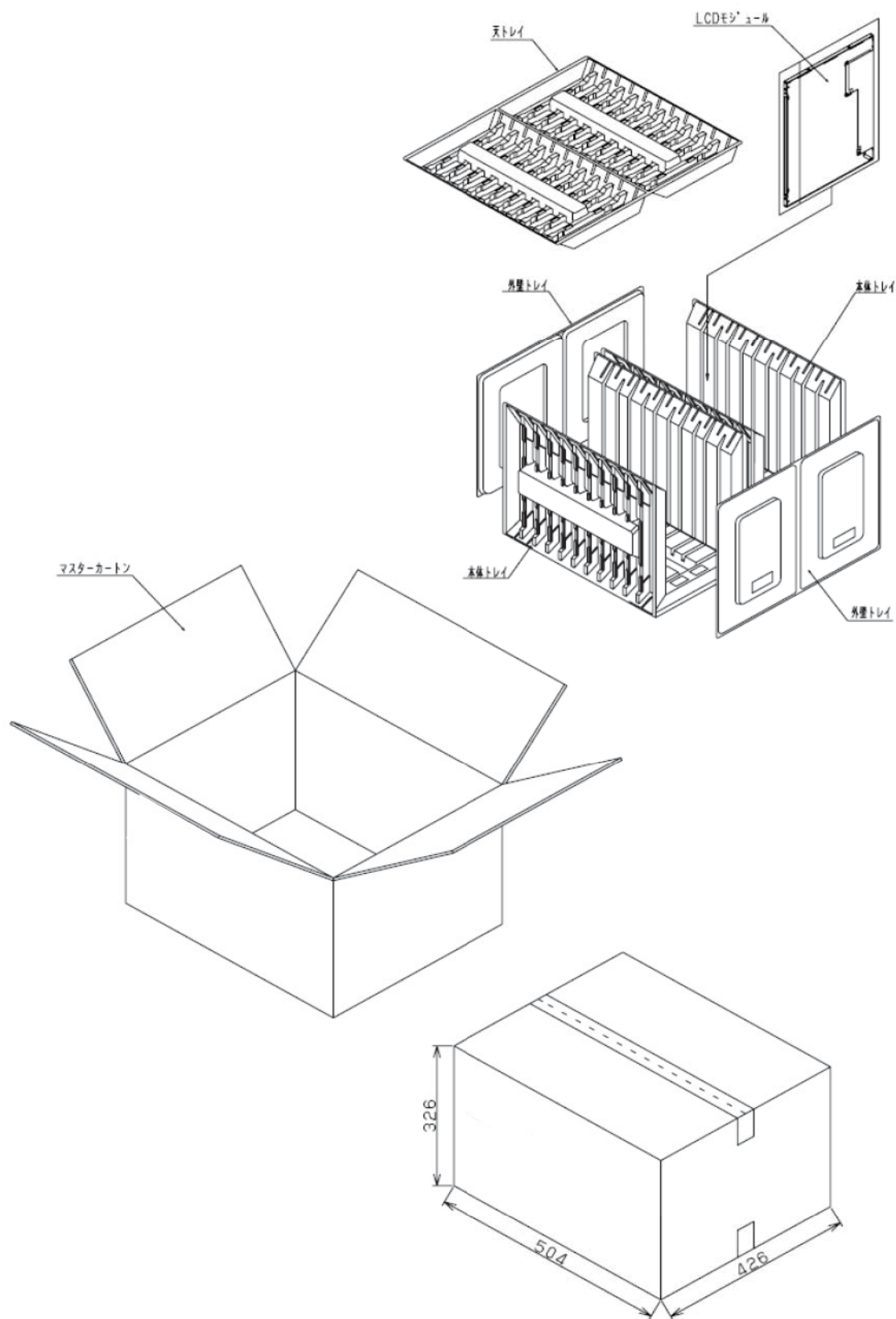

図3 包装形態図