

PREPARED BY : DATE	<h1>SHARP</h1> <p>TFT LIQUID CRYSTAL DISPLAY GROUP SHARP CORPORATION</p> <h2>SPECIFICATION</h2>	SPEC No. LD-10456 F
		FILE No.
APPROVED BY : DATE		ISSUE : Aug. 21, 1998
		PAGE : 16 pages
		APPLICABLE GROUP TFT Liquid Crystal Display Group

DEVICE SPECIFICATION

TFT-LCD Module

MODEL

LQ121S1LH02 Rev.D

CUSTOMER'S APROVAL

DATE _____

BY _____

PRESENTED

BY *Makoto Takeda*

M.TAKEDA

Department General Manager

Development Engineering Dept. II

TFT Division. II

TFT LIQUID CRYSTAL DISPLAY GROUP

SHARP CORPORATION

RECORDS OF REVISION

L Q 1 2 1 S 1 L H 0 2

SPEC No.	DATE	REVISED No.	SUMMARY		NOTE
			PAGE		
LD-10456	Aug. 21, 1998				1 st Issue
LD-10456A	Oct. 27, 1998	A	2	Drawing No. :	
			16	2D-986-602 → 2D-987-548 (TOLERANCE CCFT WIRE : 50+/-10→50+/-5) (excluding the molded protuberant portion of bezel.)	
			2	3.Mechanical specification *1.Note: excluding the molded...	
LD-10456B	Nov. 08, 1999	B	5	Vcc current dissipation (Additional model with "T" driver IC) Max 380mA	2 nd Issue
			13	11.Handling Precautions l)When some pressure.... m)Duaring the moduleaging,.... n)When handling LCD modules....	
			13	12.Packing form c)Carton size : 367(W) X 304(H) X 222(D) →251(W) X 318(H) X 410(D)	
			14	Lot No.Label: Additional model (with "T" driver IC)	
			15	Fig4.Packing Form - Label on the shipping carton -	
LD-10456C	Dec. 08, 1999	C	2	Unit outline dimensions (max)5.5(D) (max)5.7(D)* note1)excluding the molded protuberant portion of bezel.	3 rd Issue
			16	Unit outline dimensions (max)5.5(D)→(max)5.7(D)* *This is the value including the molded protuberant portion of bezel. The change is only for a clearer description of the unit outline dimension, but has no influence on the specifications or LCD module.	
LD-10456D	Jul. 12, 2000	D	2	Drawing No.: 2D-986-603 → 2D-986-602	4 th Issue
			16	Fig1.Outline Dimensions have been corrected. Drawing No.: 2D-986-603 → 2D-986-602	
LD-10456E	Oct. 25, 2000	E	2	Outline Dimension have been changed. thickness (max)5.7mm → (max)6.0mm Drawing No.: 2D-986-602 → 2D-00X-529	5 th Issue
			5	Vcc current dissipation(additional model with "T" driver IC) have been canceled.	
			14	Lot No.Label:"Rev.D" Marking have been added, and additional model have been canceled.	
			15	The label of certon box:"D" Marking have been added, and additional model have been canceled.	
			16	Outline Dimension have been changed. thickness (max)5.7mm → (max)6.0mm Drawing No.: 2D-986-602 → 2D-00X-529	
LD-10456F	Nov. 09, 2000	F	2	Mechanical specifications have been changed. thickness (max)6.0mm → (max)5.7mm Mass (max)430g,(typ)410g → (max)410g,(typ)400g Drawing No.: 2D-00X-529 → 2D-00Y-518	6 th Issue
			16	Outline Dimension have been changed. thickness (max)6.0mm → (max)5.7mm Drawing No.: 2D-00X-529 → 2D-00Y-518	

These specification sheets are the proprietary product of SHARP CORPORATION("SHARP) and include materials protected under copyright of SHARP. Do not reproduce or cause any third party to reproduce them in any form or by any means, electronic or mechanical, for any purpose, in whole or in part, without the express written permission of SHARP.

The device listed in these specification sheets was designed and manufactured for use in OA equipment.

In case of using the device for applications such as control and safety equipment for transportation(aircraft, trains, automobiles, etc.), rescue and security equipment and various safety related equipment which require higher reliability and safety, take into consideration that appropriate measures such as fail-safe functions and redundant system design should be taken.

Do not use the device for equipment that requires an extreme level of reliability, such as aerospace applications, telecommunication equipment(trunk lines), nuclear power control equipment and medical or other equipment for life support.

SHARP assumes no responsibility for any damage resulting from the use of the device which does not comply with the instructions and the precautions specified in these specification sheets.

Contact and consult with a SHARP sales representative for any questions about this device.

1. Application

This specification applies to a color TFT-LCD module, LQ121S1LH02 Rev.D.

2. Overview

This module is a color active matrix LCD module incorporating amorphous silicon TFT (Thin Film Transistor). It is composed of a color TFT-LCD panel, driver ICs, control circuit and power supply circuit and a backlight unit. Graphics and texts can be displayed on a 800 X 3 X 600 dots panel with 262,144 colors by using LVDS (Low Voltage Differential Signaling) system for interface and supplying +3.3V DC supply voltage for TFT-LCD panel driving and supply voltage for backlight.

The TFT-LCD panel used for this module has very high aperture ratio. A low-reflection and higher-color-saturation type color filter is also used for this panel. Therefore, high-brightness and high-contrast image, which is suitable for the multimedia use, can be obtained by using this module.

Optimum viewing direction is 6 o'clock.

Backlight-driving DC/AC inverter is not built in this module.

[Features]

- 1) High aperture panel ; high-brightness or low power consumption.
- 2) Brilliant and high contrast image.
- 3) Small footprint and thin shape.
- 4) Light weight.

3. Mechanical Specifications

Parameter	Specifications	Unit
Display size	31 (12.1") Diagonal	cm
Active area	246.0 (H) X 184.5 (V)	mm
Pixel format	800 (H) X 600 (V)	pixel
	(1 pixel = R+G+B dots)	
Pixel pitch	0.3075 (H) X 0.3075 (V)	mm
Pixel configuration	R,G,B vertical stripe	
Display mode	Normally white	
Unit outline dimensions *1	275.0 (W) X 199.0 (H) X (max)5.7(D)	mm
Mass	MAX. 410	g
	TYP. 400	g
Surface treatment	Anti-glare and hard-coating 2H Low reflection (~5%)	

*1.Note: excluding backlight cables.

Outline dimensions is shown in Fig. (Drawing No.: 2D-00Y-518)

4. Input Terminals

4-1. TFT-LCD panel driving

CN1 (LVDS signals and +3.3V DC power supply)

Using connector : FI-SEB20P-HF(JAE)

Corresponding connector : FI-SE20M (JAE) or FI-S20S (JAE)

Pin No.	Symbol	Function	Remark
1	V _{CC}	+3.3V power supply	
2	V _{CC}	+3.3V power supply	
3	GND		
4	GND		
5	RXIN0-	Differential data input, CH0 (negative)	LVDS
6	RXIN0+	Differential data input, CH0 (positive)	LVDS
7	GND		
8	RXIN1-	Differential data input, CH1 (negative)	LVDS
9	RXIN1+	Differential data input, CH1 (positive)	LVDS
10	GND		
11	RXIN2-	Differential data input, CH2 (negative)	LVDS
12	RXIN2+	Differential data input, CH2 (positive)	LVDS
13	GND		
14	RXCLK IN-	Differential clock input (negative)	LVDS
15	RXCLK IN+	Differential clock input (positive)	LVDS
16	GND		
17	Reserved	This should be electrically opened during operation.	
18	Reserved	This should be electrically opened during operation.	
19	GND		
20	GND		

[Note 1] To obtain the proper relation between LVDS signals and actual digital data signals, the digital signals should be inputted into the transmitter as described in the next section, 4-2.

[Note 2] The shielding case is connected with signal GND.

4-2 Interface block diagram

Corresponding Transmitter : DS90C363,DS90C383 (National semiconductor)

Using receiver : DS90CF364 (National semiconductor)

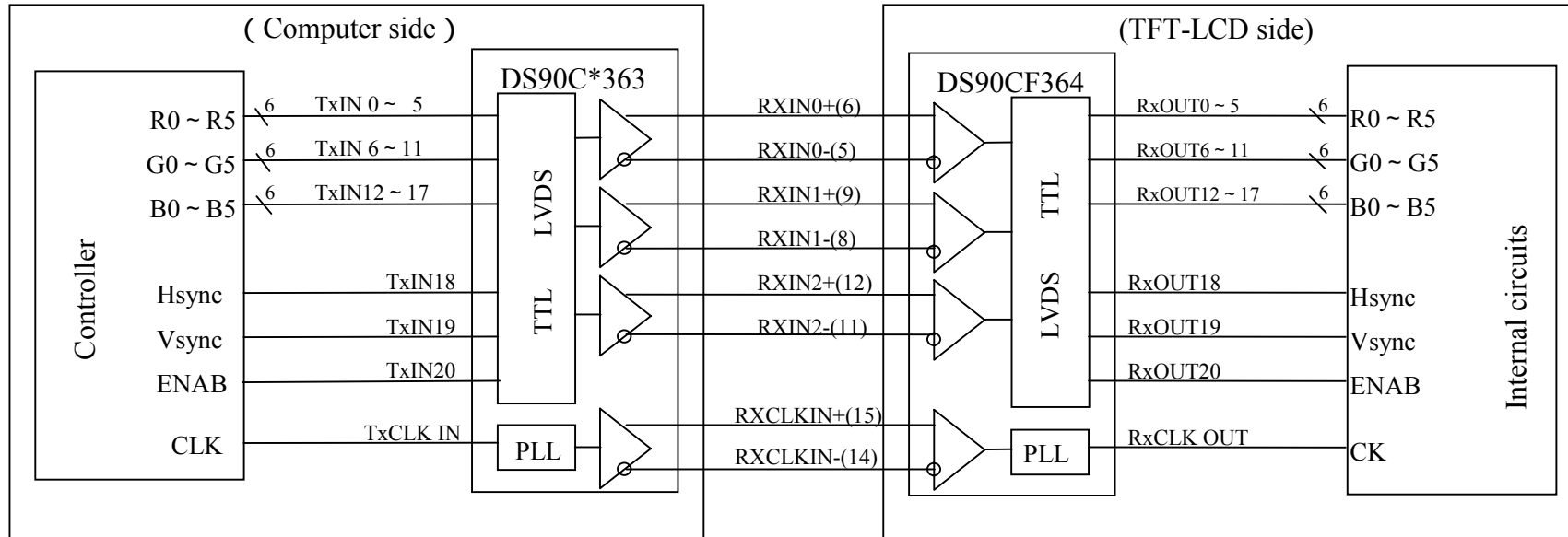

4-3. Backlight driving

CN2 : BHSR-02VS-1(JST)

Mating connector : SM02B-BHSS-1-TB(JST)

Pin no.	symbol	function
1	V_{HIGH}	Power supply for lamp (High voltage side)
2	V_{LOW}	Power supply for lamp (Low voltage side)

5. Absolute Maximum Ratings

Parameter	Symbol	Condition	Ratings	Unit	Remark
Input voltage	V_I	$T_a=25^{\circ}\text{C}$	-0.3 to $V_{CC}+0.3$	V	[Note1]
+3.3V supply voltage	V_{CC}	$T_a=25^{\circ}\text{C}$	0 to +4	V	
Storage temperature	T_{stg}	-	-25 to +60	$^{\circ}\text{C}$	[Note2]
Operating temperature (Ambient)	T_{opa}	-	0 to +50	$^{\circ}\text{C}$	

[Note1] LVDS signals

[Note2] Humidity: 95%RH Max. at $T_a \leq 40^{\circ}\text{C}$.Maximum wet-bulb temperature at 39°C or less at $T_a > 40^{\circ}\text{C}$.

No condensation.

6. Electrical Characteristics

6-1. TFT-LCD panel driving

 $T_a=25^{\circ}\text{C}$

Parameter		Symbol	Min.	Typ.	Max.	Unit	Remark
V_{CC}	Supply voltage	V_{CC}	+3.0	+3.3	+3.6	V	[Note2]
	Current dissipation	I_{CC}	-	220	300	mA	[Note3]
Permissive input ripple voltage		V_{RP}	-	-	100	mVp-p	$V_{CC}=+3.3\text{V}$
Input voltage range		V_I	0	-	2.8	V	
Differential input threshold voltage	High	V_{TH}	-	-	$V_{CM}+100$	mV	$V_{CM}=1.2\text{V}$ [Note1]
	Low	V_{TL}	$V_{CM}-100$	-	-	mV	
Input impedance		R_T	-	100	-	Ω	Differential input

[Note1] V_{CM} : Common mode voltage of LVDS driver.

[Note2]

On-off conditions for supply voltage

- $0 < t_1 \leq 10\text{ms}$
- $0 < t_2 \leq 65\text{ms}$
- $0 < t_3 \leq 1\text{s}$
- $t_4 > 1\text{s}$

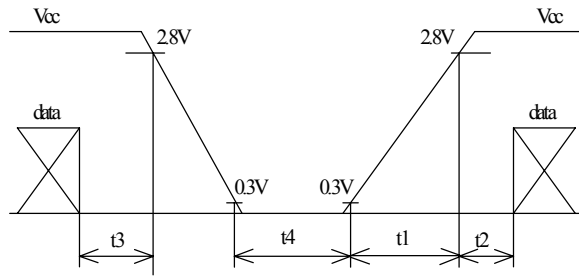

Vcc-dip conditions

- 1) $2.4\text{V} \leq V_{cc} < 3.0\text{V}$
td 10ms
- 2) $V_{cc} < 2.4\text{V}$

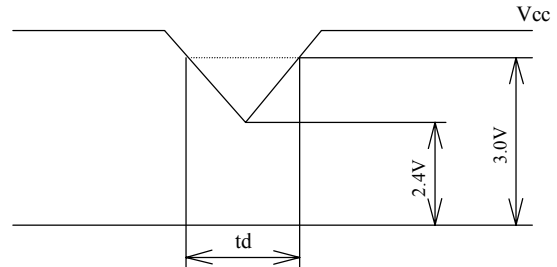

Vcc-dip conditions should also follow the On-off conditions for supply voltage

[Note3] Typical current situation : 16-gray-bar pattern.

$V_{cc} = +3.3\text{V}$

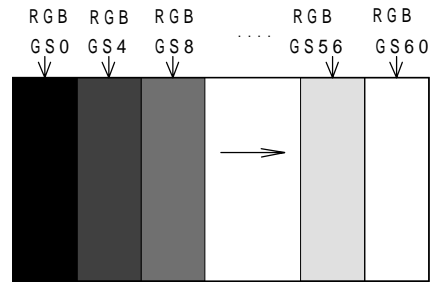

6-2. Backlight driving

The backlight system is an edge-lighting type with single CCFT (Cold Cathode Fluorescent Tube).

The characteristics of the lamp are shown in the following table.

Parameter	Symbol	Min.	Typ.	Max.	Unit	Remark
Lamp current range	I_L	2.0	2.5	6.0	mArms	[Note1]
Lamp power consumption	P_L	-	1.6	-	W	$Y_L = 70\text{cd/m}^2$
Lamp frequency	F_L	30	50	60	kHz	[Note2]
Kick-off voltage	V_s	-	-	1350	Vrms	$T_a = 25^\circ\text{C}$
		-	-	1450	Vrms	$T_a = 0^\circ\text{C}$ [Note3]
Lamp life time	L_L	10000	-	-	hour	[Note4]

[Note1] Lamp current is measured with current meter for high frequency as shown below.

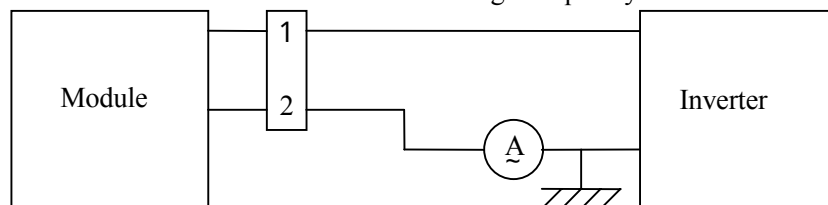

* 2 pin is V_{LOW}

[Note2] Lamp frequency may produce interference with horizontal synchronous frequency, and this may cause beat on the display. Therefore lamp frequency shall be detached as much as possible from the horizontal synchronous frequency and from the harmonics of horizontal synchronous to avoid interference.

[Note3] The voltage above this value should be applied to the lamp for more than 1 second to start-up. Otherwise the lamp may not be turned on.

[Note4] Lamp life time is defined as the time when either (1) or (2) occurs in the continuous operation under the condition of $T_a=25\text{ }^\circ\text{C}$ and $I_L=6.0\text{ mArms}$.

(1) Brightness becomes 50% of the original value under standard condition.

(2) Kick-off voltage at $T_a=0\text{ }^\circ\text{C}$ exceeds maximum value, 1450 Vrms.

Note) The performance of the backlight, for example life time or brightness, is much influenced by the characteristics of the DC-AC inverter for the lamp. When you design or order the inverter, please make sure that a poor lighting caused by the mismatch of the backlight and the inverter (miss-lighting, flicker, etc.) never occur. When you confirm it, the module should be operated in the same condition as it is installed in your instrument.

7. Timing characteristics of input signals

7-1. Timing characteristics

(These are specified at the digital inputs/outputs of LVDS transmitter/receiver.)

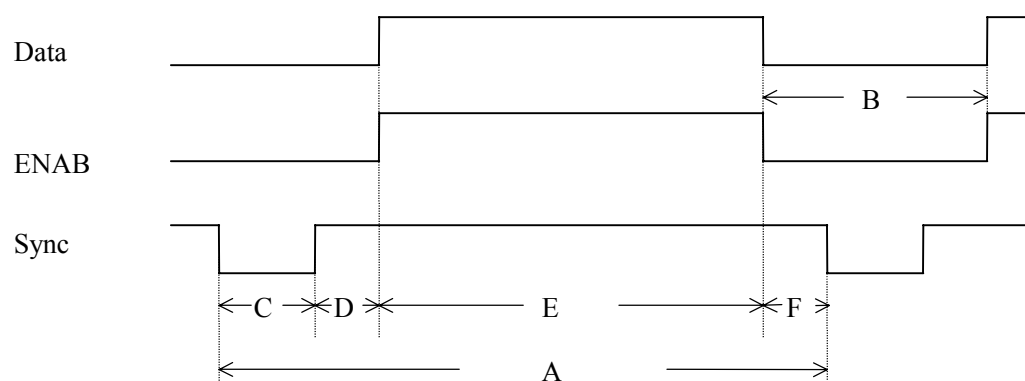

(Vertical timing)

Item (symbol)	Min.	Typ.	Max.	Unit	備考
Vsync cycle (T_{VA})	-	17.6	-	ms	Negative
	628	666	798	line	
Blanking period(T_{VB})	28	66	-	line	
Vsync pulse width (T_{VC})	2	4	6	line	
Back porch (T_{VD})	23	23	23	line	
Vsync pulse width+Back porch ($T_{VC}+T_{VD}$)	25	27	29	line	
Active display area (T_{VE})	600	600	600	line	
Front porch (T_{VF})	3	39	-	line	

(Horizontal timing)

Item (symbol)	Min.	Typ.	Max.	Unit	Remark
Hsync cycle (T_{HA})	20.8	26.4	-	μs	Negative
	1024	1056	1100	clock	
Blanking period (T_{HB})	32	256	-	clock	
Hsync pulse width (T_{HC})	4	128	200	clock	
Back porch (T_{HD})	58	88	170	clock	
Active display area (T_{HE})	800	800	800	clock	
Front porch (T_{HF})	0	40	-	clock	

(Clock signal)

Item	Min.	Typ.	Max.	Unit	Remark
Frequency	-	40	42	MHz	[Note1]

[Note1] In case of lower frequency, the deterioration of display quality, flicker etc., may be occurred.

(Hsync-Vsync Phase difference)

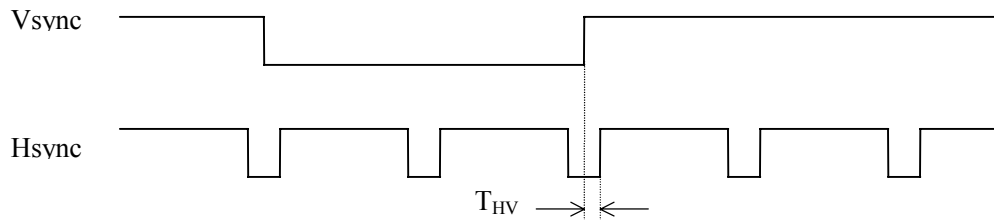

Item(symbol)	Min.	Typ.	Max.	Unit	Remark
Hsync-Vsync Phase difference (T_{HV})	0	-	$T_{HA} - T_{HC}$	clock	

(Hsync-ENAB Phase difference)

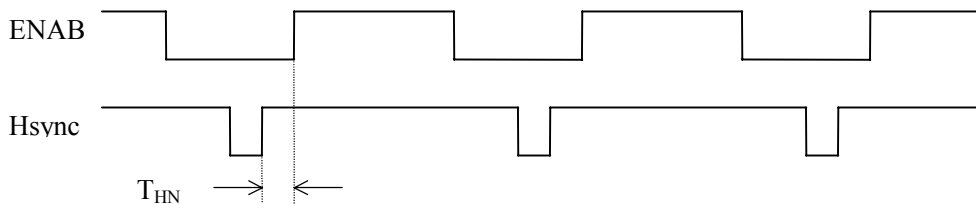

Item	Min.	Typ.	Max.	Unit	Remark
Hsync-ENAB Phase difference (T_{HN})	58	88	$T_{HA}-930$	clock	

7-2 Display position

Item	Standards	Beginning	Ending	Unit	Remark
Horizontal	rising edge of ENAB	0	800	clock	
	rising edge of Hsync	88	888	clock	[Note1]
Vertical	rising edge of Vsync	23	623	line	

[Note1] In case that ENAB signal is fixed to low level. Do not keep ENAB signal high during operation.

7-3. Input Data Signals and Display Position on the screen

Display position of input data
(H , V)

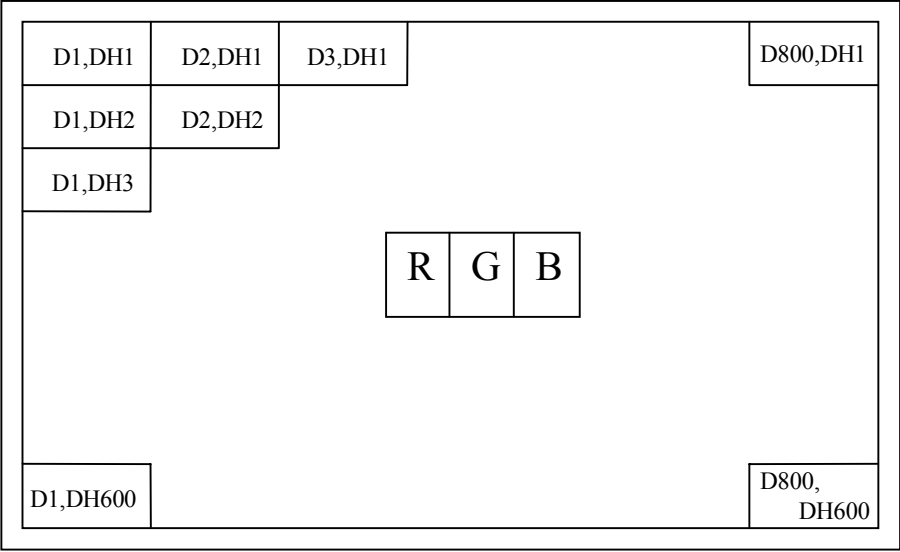

8. Input Signals, Basic Display Colors and Gray Scale of Each Color

	Colors & Gray scale	Data signal																		
		GrayScale	R0	R1	R2	R3	R4	R5	G0	G1	G2	G3	G4	G5	B0	B1	B2	B3	B4	B5
Basic Color	Black	-	0	0	0	0	0	0	0	0	0	0	0	0	0	0	0	0	0	0
	Blue	-	0	0	0	0	0	0	0	0	0	0	0	0	1	1	1	1	1	1
	Green	-	0	0	0	0	0	0	1	1	1	1	1	1	0	0	0	0	0	0
	Cyan	-	0	0	0	0	0	0	1	1	1	1	1	1	1	1	1	1	1	1
	Red	-	1	1	1	1	1	1	0	0	0	0	0	0	0	0	0	0	0	0
	Magenta	-	1	1	1	1	1	1	0	0	0	0	0	0	1	1	1	1	1	1
	Yellow	-	1	1	1	1	1	1	1	1	1	1	1	1	0	0	0	0	0	0
	White	-	1	1	1	1	1	1	1	1	1	1	1	1	1	1	1	1	1	1
Gray Scale of Red	Black	GS0	0	0	0	0	0	0	0	0	0	0	0	0	0	0	0	0	0	0
	↑	GS1	1	0	0	0	0	0	0	0	0	0	0	0	0	0	0	0	0	0
	Darker	GS2	0	1	0	0	0	0	0	0	0	0	0	0	0	0	0	0	0	0
	↑	↓			↓					↓					↓					
	↓	↓			↓					↓					↓					
	Brighter	GS61	1	0	1	1	1	1	0	0	0	0	0	0	0	0	0	0	0	0
	↓	GS62	0	1	1	1	1	1	0	0	0	0	0	0	0	0	0	0	0	0
	Red	GS63	1	1	1	1	1	1	0	0	0	0	0	0	0	0	0	0	0	0
Gray Scale of Green	Black	GS0	0	0	0	0	0	0	0	0	0	0	0	0	0	0	0	0	0	0
	↑	GS1	0	0	0	0	0	0	1	0	0	0	0	0	0	0	0	0	0	0
	Darker	GS2	0	0	0	0	0	0	0	1	0	0	0	0	0	0	0	0	0	0
	↑	↓			↓					↓					↓					
	↓	↓			↓					↓					↓					
	Brighter	GS61	0	0	0	0	0	0	1	0	1	1	1	1	0	0	0	0	0	0
	↓	GS62	0	0	0	0	0	0	0	1	1	1	1	1	0	0	0	0	0	0
	Green	GS63	0	0	0	0	0	0	1	1	1	1	1	1	0	0	0	0	0	0
Gray Scale of Blue	Black	GS0	0	0	0	0	0	0	0	0	0	0	0	0	0	0	0	0	0	0
	↑	GS1	0	0	0	0	0	0	0	0	0	0	0	0	1	0	0	0	0	0
	Darker	GS2	0	0	0	0	0	0	0	0	0	0	0	0	0	1	0	0	0	0
	↑	↓			↓					↓					↓					
	↓	↓			↓					↓					↓					
	Brighter	GS61	0	0	0	0	0	0	0	0	0	0	0	0	1	0	1	1	1	1
	↓	GS62	0	0	0	0	0	0	0	0	0	0	0	0	0	1	1	1	1	1
	Blue	GS63	0	0	0	0	0	0	0	0	0	0	0	0	1	1	1	1	1	1

0 :Low level voltage, 1 : High level voltage

Each basic color can be displayed in 64 gray scales from 6 bit data signals. According to the combination of total 18 bit data signals, the 262,144-color display can be achieved on the screen.

9. Optical Characteristics

Ta=25°C, Vcc=+3.3V

Parameter		Symbol	Condition	Min.	Typ.	Max.	Unit	Remark
Viewing angle range	Horizontal	θ_{21}, θ_{22}	CR>10	45	-	-	Deg.	[Note1,4]
	Vertical	θ_{11}		10	-	-	Deg.	
		θ_{12}		30	-	-	Deg.	
Contrast ratio		CRn	$\theta=0^\circ$	150	-	-		[Note2,4]
		CRo	Optimum viewing angle	-	300	-		
Response time	Rise	τ_r	$\theta=0^\circ$	-	15	-	ms	[Note3,4]
	Decay	τ_d		-	30	-	ms	
Chromaticity of white		x		0.263	0.313	0.363		[Note4]
		y		0.279	0.329	0.379		
Luminance of white [Note4]		Y_{L1}		50	70	-	cd/m ²	$I_L=2.5\text{mA rms}$
		Y_{L2}		120	160	-		$I_L=6.0\text{mA rms}$
White Uniformity		w		-	-	1.45		[Note5]

The measurement shall be executed 30 minutes after lighting at rating.

(typical condition: $I_L = 2.5 \text{ mA rms}$)

The optical characteristics shall be measured in a dark room or equivalent state with the method shown in Fig.3 below.

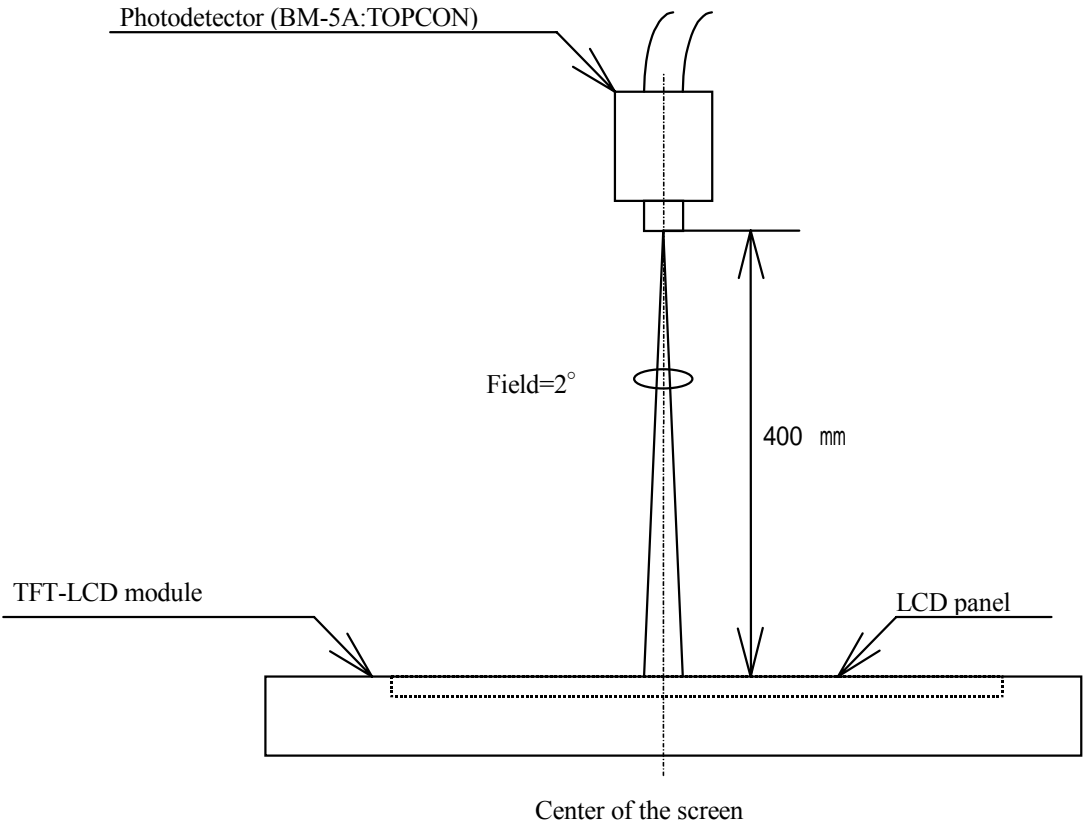
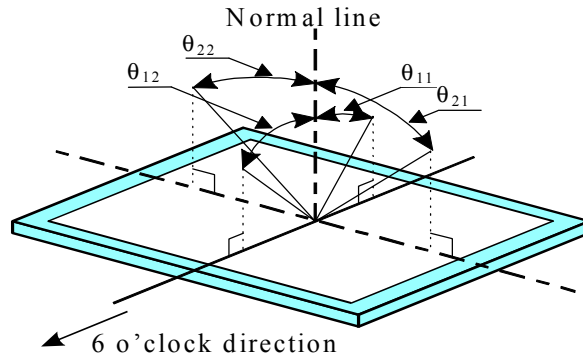

Fig.3 Optical characteristics measurement method

[Note1]Definitions of viewing angle range:



[Note2]Definition of contrast ratio:

The contrast ratio is defined as the following.

$$\text{Contrast Ratio (CR)} = \frac{\text{Luminance (brightness) with all pixels white}}{\text{Luminance (brightness) with all pixels black}}$$

[Note3]Definition of response time:

The response time is defined as the following figure and shall be measured by switching the input signal for "black" and "white" .

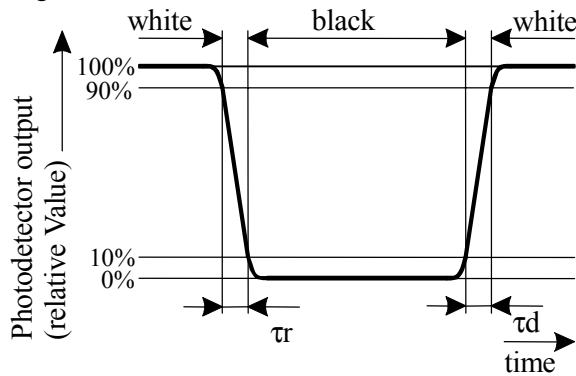

[Note4]This shall be measured at center of the screen.

[Note5]Definition of white uniformity:

White uniformity is defined as the following with five measurements (A~E).

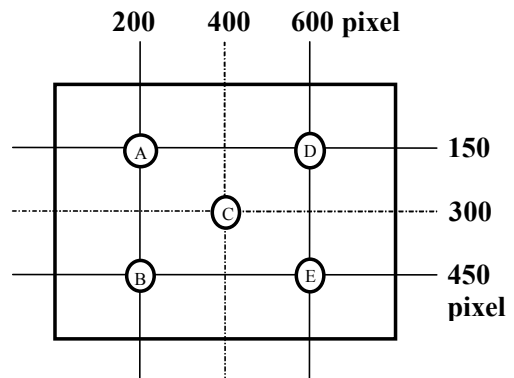

$$\delta_w = \frac{\text{Maximum Luminance of five points(brightness)}}{\text{Minimum Luminance of five points(brightness)}}$$

10. Display Quality

The display quality of the color TFT-LCD module shall be in compliance with the Incoming Inspection Standard.

11. Handling Precautions

- a) Be sure to turn off the power supply when inserting or disconnecting the cable.
- b) Be sure to design the cabinet so that the module can be installed without any extra stress such as warp or twist.
- c) Since the front polarizer is easily damaged, pay attention not to scratch it.
- d) Wipe off water drop immediately. Long contact with water may cause discoloration or spots.
- e) When the panel surface is soiled, wipe it with absorbent cotton or other soft cloth.
- f) Since the panel is made of glass, it may break or crack if dropped or bumped on hard surface.
Handle with care.
- g) Since CMOS LSI is used in this module, take care of static electricity and injure the human earth when handling.
- h) Observe all other precautionary requirements in handling components.
- i) This module has its circuitry PCBs on the rear side and should be handled carefully in order not to be stressed.
- j) Laminated film is attached to the module surface to prevent it from being scratched . Peel the film off slowly just before the use with strict attention to electrostatic charges. Ionized air shall be blown over during the action. Blow off the 'dust' on the polarizer by using an ionized nitrogen gun, etc..
- k) Black PET sheet covers some electric components and handle with special care to avoid mechanical stress and shock on this PET surface.
- l) When some pressure is added onto the module from rear side constantly , it causes display non-uniformity issue , functional defect , etc . So , please avoid such design .
- m) Duaring the module aging , don't put protection film on the module surface.
- n) When handling LCD modules and assembling them into cabinets, please be noted that long-term storage in the environment of oxidization or deoxidization gas and the use of such materials as reagent,solvent, adhesive, resin, etc. which generate these gasses, may cause corrosion and discoloration of the LCD modules.

12. Packing form

- a) Piling number of cartons : MAX.8
- b) Package quantity in one carton : 10pcs
- c) Carton size : 251 (W) × 318(H) × 410(D) mm
- d) Total mass of one carton filled with full modules : 5400 g

Packing form is shown in Fig . 4

13. Reliability test items

No.	Test item	Conditions
1	High temperature storage test	Ta=60 °C 240h
2	Low temperature storage test	Ta=-25 °C 240h
3	High temperature & high humidity operation test	Ta=40 °C ; 95%RH 240h (No condensation)
4	High temperature operation test	Ta=50 °C 240h (The panel temp. must be less than 60 °C)
5	Low temperature operation test	Ta=0 °C 240H
6	Vibration test (non- operating)	Frequency :10 ~ 57Hz/Vibration width (one side):0.075mm : 58 ~ 500Hz/Gravity:9.8m/s ² Sweep time : 11 minutes Test period : 3 hours (1 hour for each direction of X,Y,Z)
7	Shock test (non- operating)	Max. gravity : 490m/s ² Pulse width : 11ms, sine wave Direction : +/- X, +/- Y, +/- Z once for each direction.

14 . Others

1) Lot No. Label:

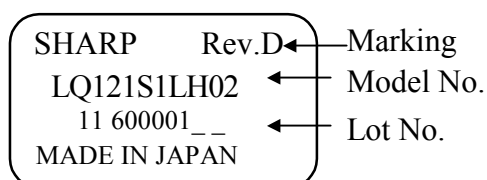

2) Adjusting volume have been set optimally before shipment, so do not change any adjusted value.

If adjusted value is changed, the specification may not be satisfied.

3) Disassembling the module can cause permanent damage and should be strictly avoided.

4) Please be careful since image retention may occur when a fixed pattern is displayed for a long time.

5) If any problem occurs in relation to the description of this specification , it shall be resolved through discussion with spirit of cooperation.

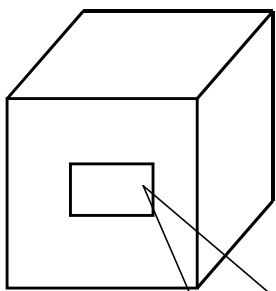
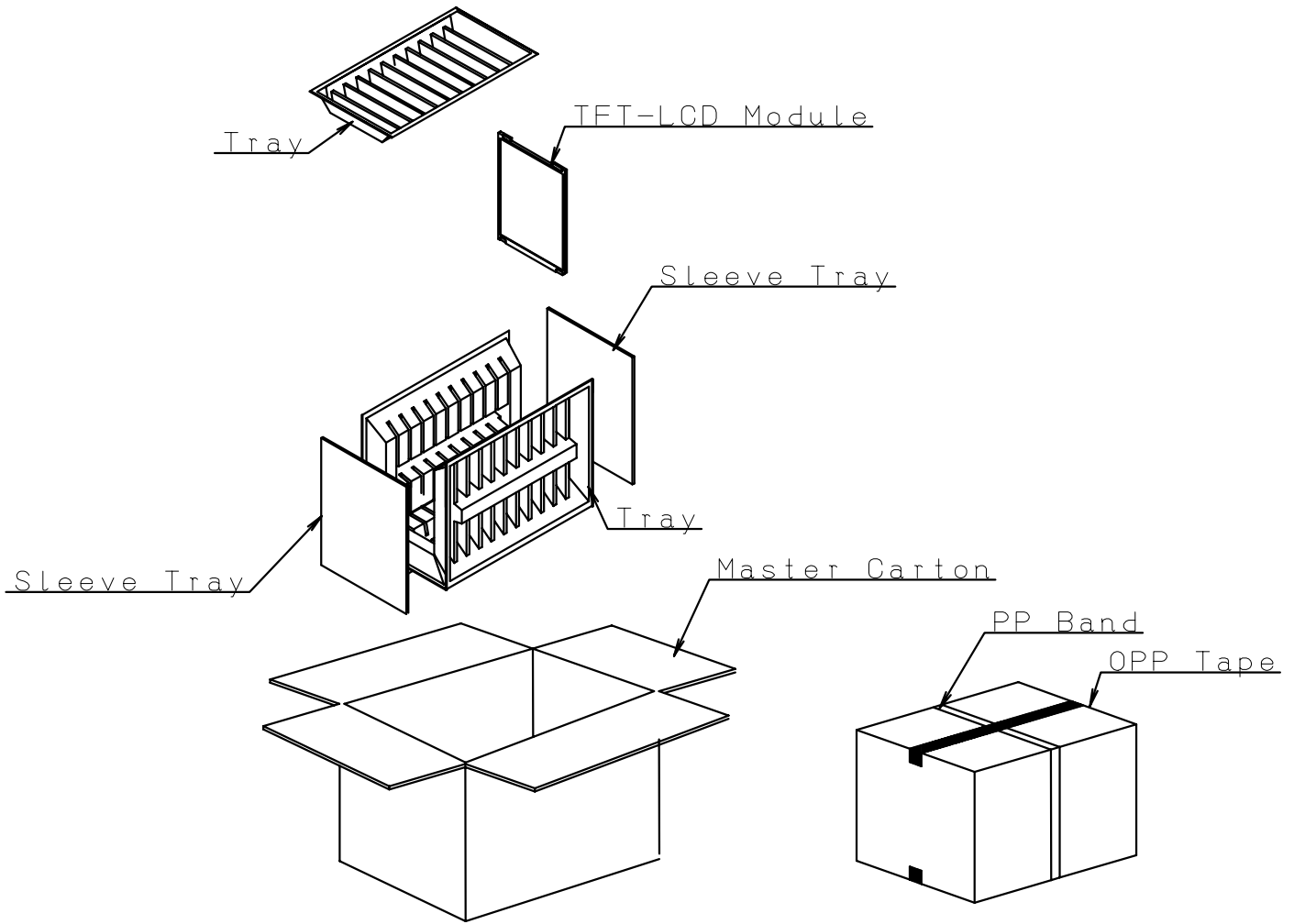

Shipping carton

LQ121S1LH02 Rev.D
Case 1) Japan product

TYPE	Packing barcode label (Please refer to the drawing on the right) *Barcode labels are applied to cartons of Japan product only.
QUANTITY	
DATE	

Case 2) Taiwan product

TYPE	LQ121S1LH02
	LQ121S1LH02D
QUANTITY	
DATE	

社内品番:(4S)LQ121S1LH02	
Lot No.:(1T)2000.01.01	
Quantity:(Q)10pcs	
ユーザー品番:	
シャープ物流用ラベルです。 LQ121S1LH02D	

- ← "D" Marking
- ← Model No.
- ← Lot No.(DATE)
- ← Quantity
- ← User Model No.

← "D" Marking

Sharp internal Model No. for LCD modules in the carton will be shown here.

Fig4. Packing Form

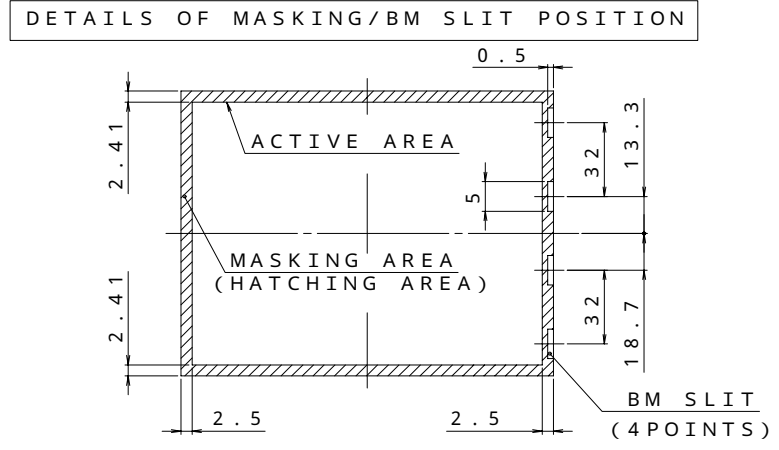
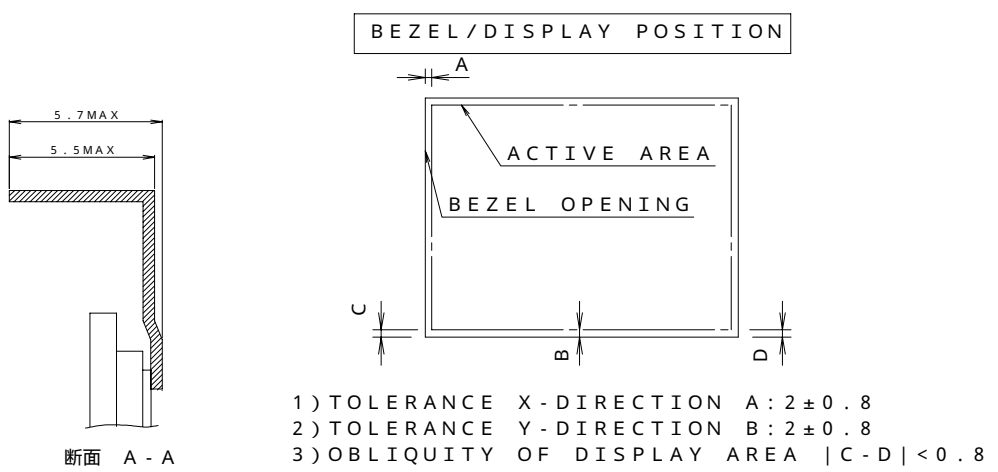
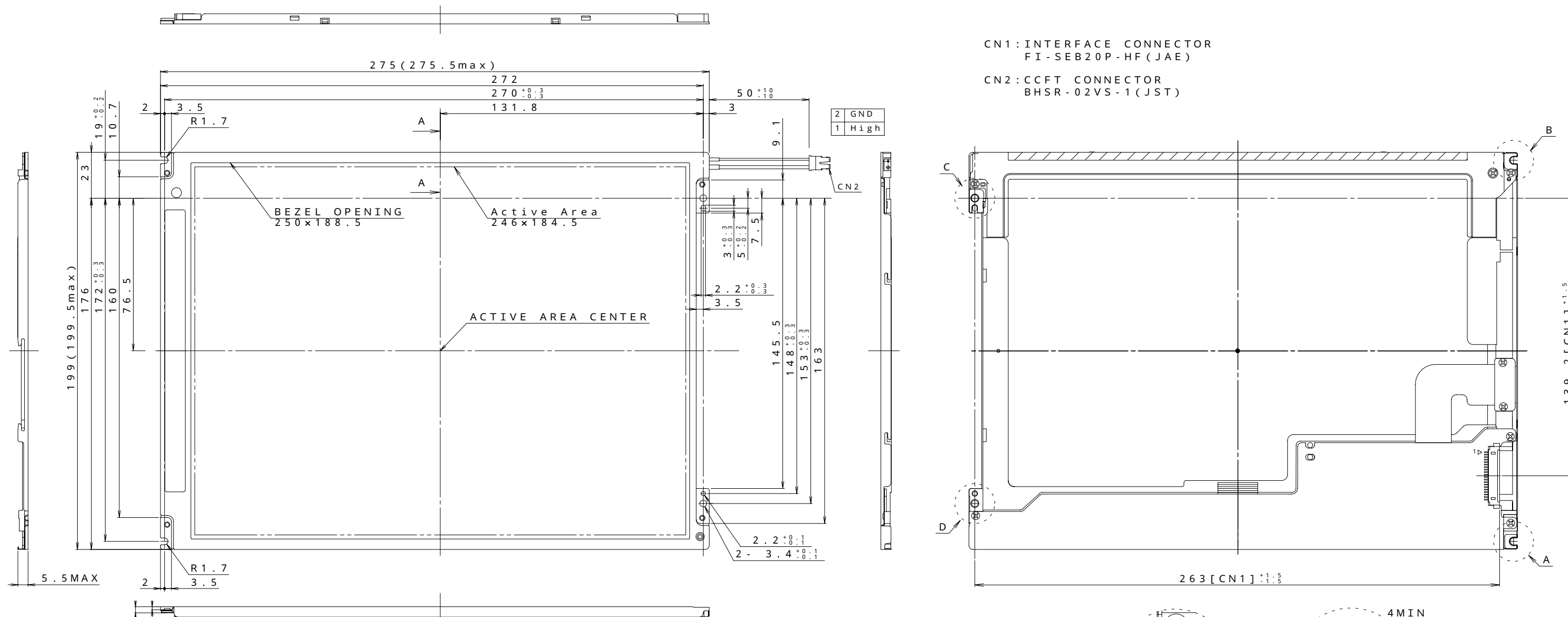

BM SLIT: THE POSITION LOOKED DIFFERENT COLOR (LIKE BROWN) AT THE MASKING PORTION. THERE IS NO LIGHT LEAKAGE AT THE SLIT. (BM IS AN ABBREVIATION OF BLACK MASK)

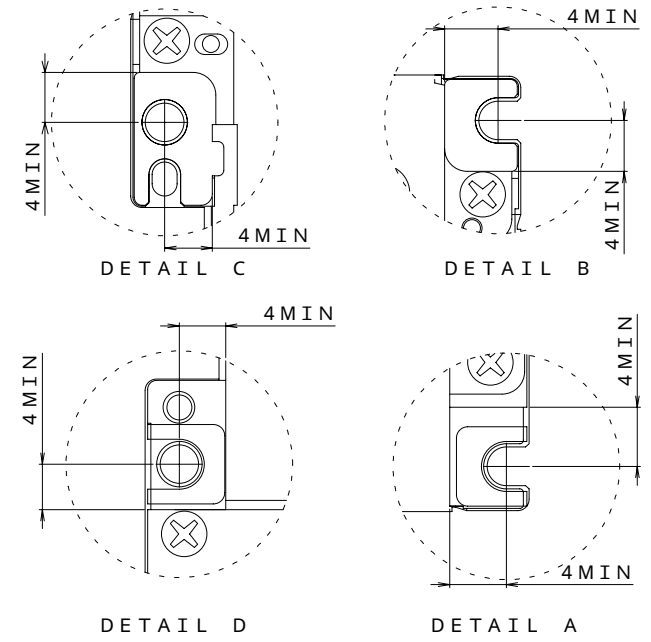

- NOTES
- UNSPECIFIED TOLERANCE TO BE ± 0.5
 - WARP AND FLATING FOR THE COMPONENTS OF TAPE, BEZEL PCB AND CHASSIS etc. ARE EXCLUDED FROM THICKNESS AND DIMENSION OF THE UNIT.
 - NOT PRESSED BACKSIDE OF THE UNIT.

Fig1. OUTLINE DIMENSIONS