

PREPARED BY : DATE	SHARP	SPEC No. LD-D2114Z07B
APPROVED BY : DATE		FILE No.
		ISSUE : Apr. 14. 2015
	DISPLAY DEVICE BUSINESS DIVISION SHARP CORPORATION	PAGE : 28 pages
	SPECIFICATION	APPLICABLE GROUP DISPLAY DEVICE BUSINESS DIVISION II

DEVICE SPECIFICATION FOR
TFT-LCD Module
 MODEL No.
LQ125T1JW02

CUSTOMER'S APPROVAL

DATE _____

BY _____

PRESENTED

BY *T. Ito*

T. ITO
 Department General Manager
 DEVELOPMENT DEPARTMENT
 DISPLAY DEVICE UNIT V
 DISPLAY DEVICE BUSINESS DIVISION II
 SHARP CORPORATION

NOTICE

This specification is the proprietary of SHARP and is copyrighted, with all rights reserved. Under the copyright laws, no part of this technical literature may be reproduced or transmitted in any form or by any means, electronic or mechanical for any purpose, in whole or in part, without the express written permission of SHARP. Express written permission is also required before any use of this technical literature may be made by a third party.

The application circuit examples in this technical literature are provided to explain the representative applications of SHARP's devices and are not intended to guarantee any circuit design or permit any industrial property right or other rights to be executed. SHARP takes no responsibility for any problems related to any industrial property right or a third party resulting from the use of SHARP's devices, except for those resulting directly from device manufacturing processes.

In the absence of confirmation by device specification sheets, SHARP takes no responsibility for any defects that occur in equipment using any of SHARP's devices, shown in catalogs, data books, etc. Contact SHARP in order to obtain the latest device specification sheets before using any SHARP's device.

SHARP reserves the right to make changes in the specifications, characteristics, data, materials, structures and other contents described herein at any time without notice in order to improve design or reliability. Contact SHARP in order to obtain the latest specification sheets before using any SHARP's device. Manufacturing locations are also subject to change without notice.

Observe the following points when using any device in this technical literature. SHARP takes no responsibility for damage caused by improper use of the devices.

The devices in this technical literature are designed for general electronic equipment use.

The appropriate design measures should be taken to ensure reliability and safety when SHARP's devices are used for equipment such as:

- Transportation control and safety equipment(i.e., aircraft, trains, automobiles, etc.)
- Traffic signals • Gas leakage sensor breakers • Alarm equipment • Various safety devices etc.

SHARP's devices shall not be used for equipment that requires extremely high level of reliability, such as:

- Military and space applications • Nuclear power control equipment
- Medical equipment for life support

Contact a SHARP representative, in advance, when intending to use SHARP's devices for any "specific" applications other than those recommended by SHARP.

Contact and consult with a SHARP representative if there are any questions about the contents of this technical literature.

Table of contents

1. Application.....	3
2. Overview.....	3
3. Mechanical Specifications	3
4. Input Terminals.....	4
4 - 1. Symbol.....	4
4 - 2. eDP interface.....	6
5. Absolute Maximum Ratings	8
6. Electrical Characteristics.....	9
6 - 1. TFT-LCD panel driving.....	9
6 - 2. Backlight driving	12
7. Timing Characteristics of Input Signals.....	13
7 - 1. Timing characteristics.....	13
7 - 2. Input data signals and display position on the screen	14
8. Input Signals, Basic Display Colors and Gray Scale of Each Color.....	15
9. EDID Specifications	16
9 - 1. EDID data structure	16
10. Optical Characteristics.....	20
11. Display Quality.....	21
12. About Handling	22
12-1. Handling Precautions.....	22
12-2. Precautions for Handling Tray.....	23
13. Packaging Condition.....	24
14. Label	25
15. RoHS Directive.....	26
16. Halogen Free.....	26
17. Reliability Test Item.....	26
Fig. 1 Packaging Condition.....	27
Fig. 2 Outline Dimension	28

1. Application

This specification applies to a color TFT-LCD module, LQ125T1JW02.

2. Overview

This module is a color active matrix LCD module incorporating Oxide TFT (Thin Film Transistor). It is composed of a color TFT-LCD panel, driver ICs, a control circuit and power supply circuit, and a backlight unit. Graphics and texts can be displayed on a 2560×3×1440 dots panel with 16,777,216 colors by using eDP (Embedded Display Port) Ver1.3 interface and supplying +3.3V DC supply voltage for TFT-LCD panel driving and applying DC supply voltage for LED backlight-driving DC/DC converter.

In this TFT-LCD panel, color filters for excellent color performance and backlights for high brightness are incorporated to realize brighter and clearer pictures, making this model optimum for use in multi-media applications.

Optimum viewings are in all directions.

Backlight-driving LED controller is built in this module.

eDP Transfer rate Specification : 2.7Gbps / 4 lane

3. Mechanical Specifications

Parameter	Specifications	Unit
Display size	31.75 (12.5") Diagonal	cm
Active area	276.48(H)×155.52 (V)	mm
Pixel format	2560 (H)×1440 (V)	pixel
	(1 pixel = R+G+B dots)	
Pixel pitch	0.108 (H) × 0.108 (V)	mm
Pixel configuration	R,G,B vertical stripe	
Display mode	Normally black	
Surface treatment	Anti-glare coating	
	Hard coating (2H)	

Outline dimensions

Parameter		Min.	Typ.	Max.	Unit	Remark
Unit outline dimensions [Note 3-1]	Width	282.18	282.68	283.18	mm	
	Height	178.16	178.66	179.16	mm	w/ PCB w/ Shielding tape
	Depth	1.9	2.1	2.3	mm	w/o PCB
Mass				175	g	w/ Shielding tape

[Note 3-1] Outline dimensions is shown in Fig.2

4. Input Terminals

4 - 1. Symbol

CN1 (eDP signals, +3.3V DC power supply, and B/L power supply)

Pin No.	Symbol	I/O	Function	Remark
1	NC	-	Reserved for LCD manufacturer's use	[Note4-1-1]
2	H_GND	P	High Speed Ground	
3	Lane3_N	I	Complement Signal Link Lane 3	
4	Lane3_P	I	True Signal Link Lane 3	
5	H_GND	P	High Speed Ground	
6	Lane2_N	I	Complement Signal Link Lane 2	
7	Lane2_P	I	True Signal Link Lane 2	
8	H_GND	P	High Speed Ground	
9	Lane1_N	I	Complement Signal Link Lane 1	
10	Lane1_P	I	True Signal Link Lane 1	
11	H_GND	P	High Speed Ground	
12	Lane0_N	I	Complement Signal Link Lane 0	
13	Lane0_P	I	True Signal Link Lane 0	
14	H_GND	P	High Speed Ground	
15	AUX_CH_P	I	True Signal Auxiliary Channel	
16	AUX_CH_N	I	Complement Signal Auxiliary Channel	
17	H_GND	P	High Speed Ground	
18	VDD	-	LCD logic and driver power(3.3V)	
19	VDD	-	LCD logic and driver power(3.3V)	
20	VDD	-	LCD logic and driver power(3.3V)	
21	VDD	-	LCD logic and driver power(3.3V)	
22	NC	-	Reserved for LCD manufacturer's use	[Note4-1-1]
23	LCD_GND	P	LCD logic and driver ground	
24	LCD_GND	P	LCD logic and driver ground	
25	LCD_GND	P	LCD logic and driver ground	
26	LCD_GND	P	LCD logic and driver ground	
27	HPD	O	HPD signal pin	[Note4-1-3]
28	BL_GND	P	Backlight ground	
29	BL_GND	P	Backlight ground	
30	BL_GND	P	Backlight ground	
31	BL_GND	P	Backlight ground	
32	BL_ENABLE	I	Backlight On/Off	[Note4-1-4]
33	BL_PWM_DIM	I	System PWM	[Note4-1-5]
34	NC	-	Reserved for LCD manufacturer's use	[Note4-1-1]
35	NC	-	Reserved for LCD manufacturer's use	[Note4-1-1]
36	VBL	P	Backlight power	
37	VBL	P	Backlight power	
38	VBL	P	Backlight power	
39	VBL	P	Backlight power	
40	NC	-	Reserved for LCD manufacturer's use	[Note4-1-1]

※1 I : Input , O : Output , P : Power:

[Note 4-1-1] Don't input any signals or any powers into a NC pin. Keep the NC pin open..

[Note 4-1-2] The shielding case is connected with signal GND.

- Connector used : 20455-040E-12 (IPEX) or equivalent
- Corresponding connector : 20454-040T

(Sharp is not responsible to its product quality, if the user applies a connector not corresponding to the above model.)

[Note 4-1-3] Output circuit is as below.

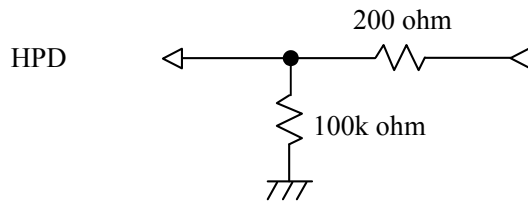

[Note 4-1-4] Input circuit is as below.

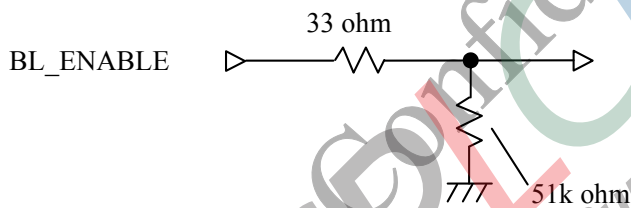

[Note 4-1-5] Input circuit is as below.

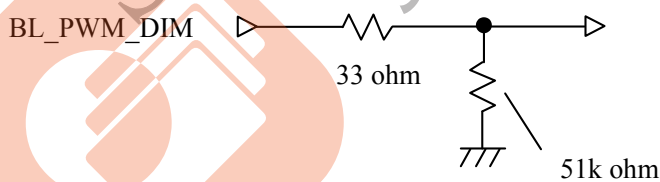

[Note 4-1-6] All terminals except NC terminal must be connected to input signal described as above or supply voltage or GND each.

4 - 2. eDP interface

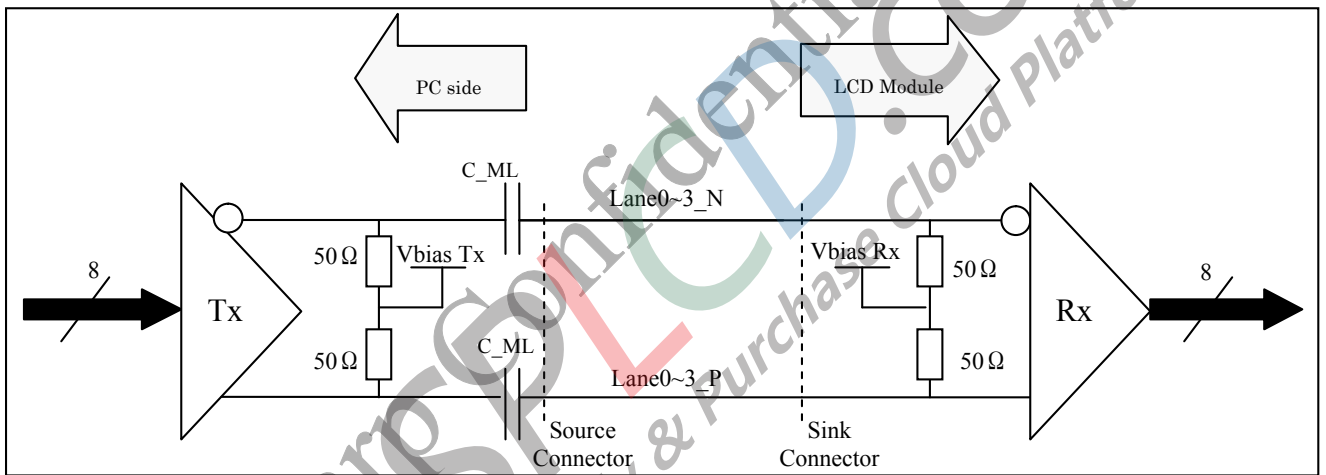
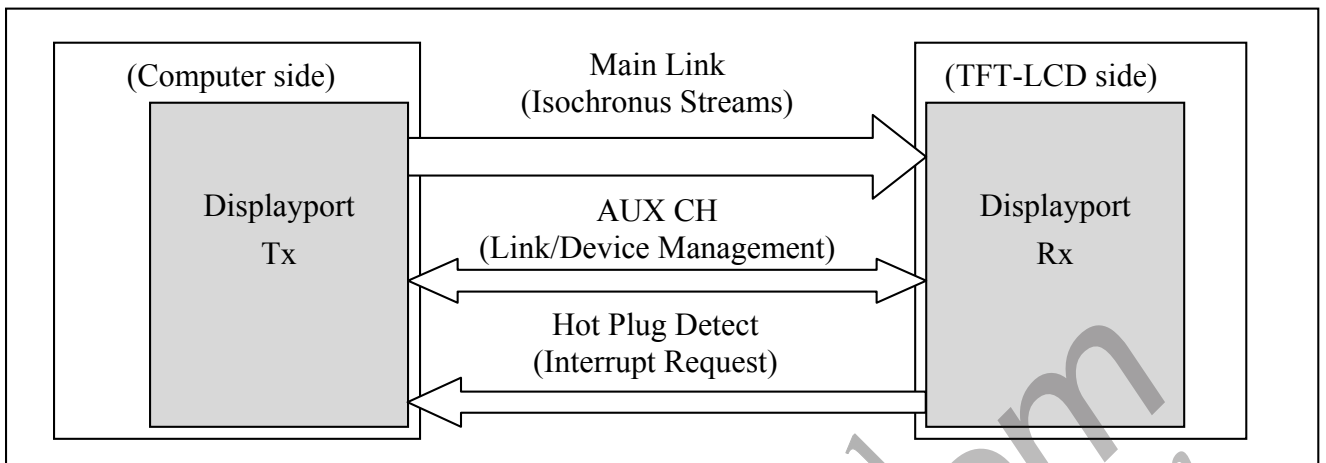

Fig.4-2-2 Main Link differential pair.

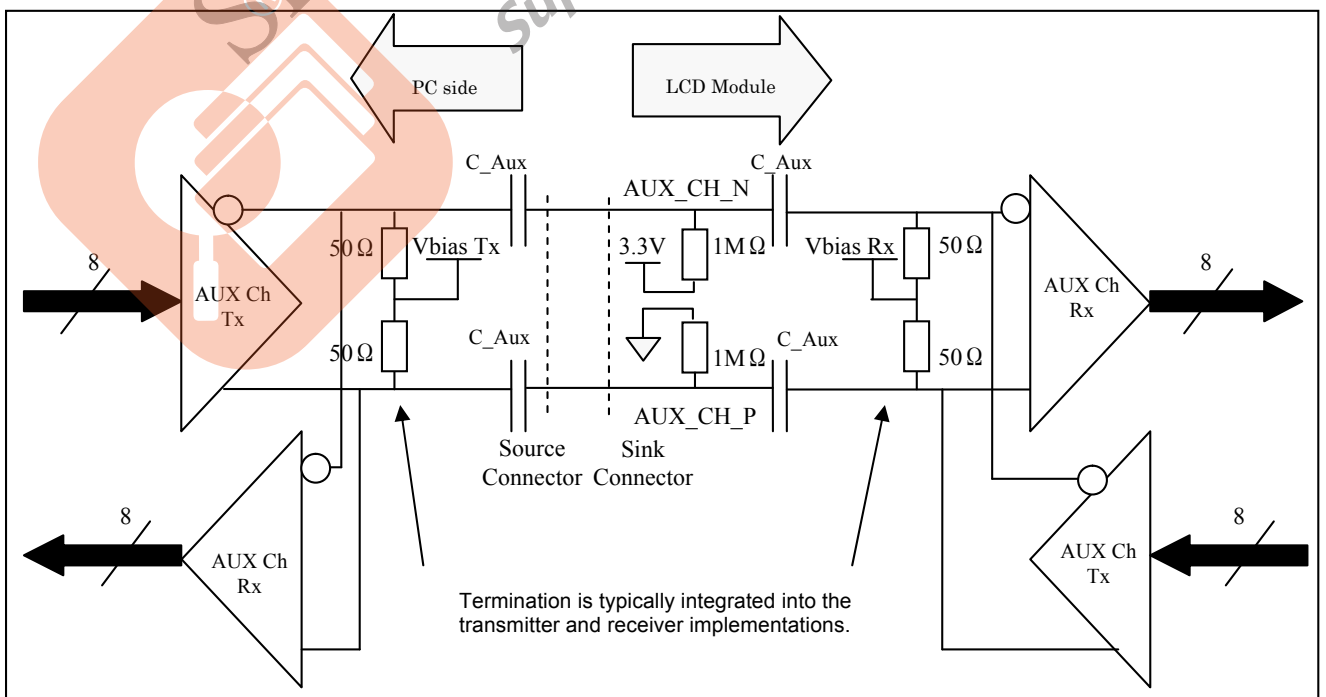
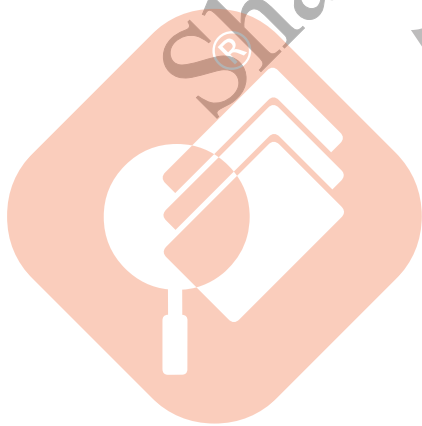

Fig.4-2-3 AUX Link differential pair.

Lane0	Lane1	Lane2	Lane3
R0-7:0	R1-7:0	R2-7:0	R3-7:0
G0-7:0	G1-7:0	G2-7:0	G3-7:0
B0-7:0	B1-7:0	B2-7:0	B3-7:0
R4-7:0	R5-7:0	R6-7:0	R7-7:0
G4-7:0	G5-7:0	G6-7:0	G7-7:0
B4-7:0	B5-7:0	B6-7:0	B7-7:0
R8-7:0	R9-7:0	R10-7:0	R11-7:0
G8-7:0	G9-7:0	G10-7:0	G11-7:0
B8-7:0	B9-7:0	B10-7:0	B11-7:0

Fig.4-2-4 eDP 4 lane 8 bit input data mapping.



Sharp Confidential
Supply & Purchase Cloud Platform

5. Absolute Maximum Ratings

Parameter	Symbol	Condition	Ratings		Unit	Remark
			Min.	Max.		
+3.3V supply voltage	VDD	Ta=25°C	-0.3	+4.0	V	
Back Light supply voltage	VBL	Ta=25°C	-0.3	+26.5	V	
Input voltage(eDP)	VI	Ta=25°C	-0.3	+1.1	V	[Note 5-1]
Input voltage(BL)	VCNT VPWM	Ta=25°C	-0.3	VDD+0.3	V	[Note 5-2]
Storage temperature (ambient)	Tstg	—	-20	+60	°C	[Note 5-3]
Operating temperature(ambient)	Topa	—	0	+50	°C	

[Note 5-1] eDP signals

[Note 5-2] Back light control signals (BL_ENABLE, PWM_DIM)

[Note 5-3] Humidity : 90%RH Max. at Ta ≤ +40°C.

Maximum wet-bulb temperature at +39°C or less at Ta > +40°C.

No condensation.

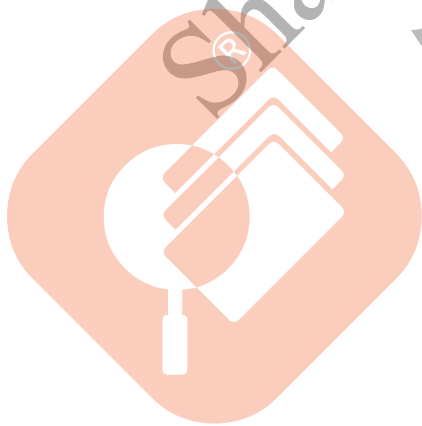

Sharp Confidential.COM
Supply & Purchase Cloud Platform

6. Electrical Characteristics

6 - 1. TFT-LCD panel driving

T_a = +25°C

DC Electrical Characteristics						
Parameter	Symbol	Min.	Typ.	Max.	Unit	Remark
Supply voltage	VDD	+3.0	+3.3	+3.6	V	[Note 6-1-1]
Current dissipation	IDD	—	406	785	mA	[Note 6-1-2]
Power dissipation	PDD		1.34	2.59	W	[Note 6-1-2]
Permissive input ripple voltage	V _{RP}	—	—	100	mV _{P-P}	VDD = +3.3V
eDP AUX Channel Characteristics						
Parameter	Symbol	Min.	Typ.	Max.	Unit	Remark
Unit Interval for AUX channel	UI _{AUX}	0.4	0.5	0.6	μs	
peak-to-peak voltage at TP1	V _{AUX-DIFF-p}	0.32	-	1.36	V	
AUX DC Common Mode Voltage	V _{AUX-DC-CM}	0	-	2.0	V	
AUX Short Circuit Current Limit	I _{AUX-SHORT}	-	-	90	mA	
AUX CH termination DC resistance	R _{AUX-TERM}	-	100	-	Ω	
AUX AC Coupling Capacitor	C _{AUX}	75	-	200	nF	
Number of pre-charge pulses	Pre-charge Pulses	10	-	16	-	
eDP Main Link Receiver Characteristics						
Parameter	Symbol	Min.	Typ.	Max.	Unit	Remark
Link clock down spreading	Down_Spread_Amplitude	0	-	0.5	%	
Differential Peak-to-peak Input Voltage at RX package pins	V _{RX-DIFF-p}	90	-	1200	mV	
Differential Return Loss at 1.35 GHz at RX package pins	RL _{RX-DIFF}	9	-	-	dB	
Differential termination resistance	V _{RX-TERM}	-	100	-	Ω	
RX Short Circuit Current Limit	I _{RX-SHORT}	-	-	50	mA	
Lane Intra-pair Skew at RX package pins	L _{RX-SKEW-INTRA-PAIR-High-Bit-Rate}	-	-	60	ps	

[Note 6-1-1] ON-OFF conditions for supply voltage

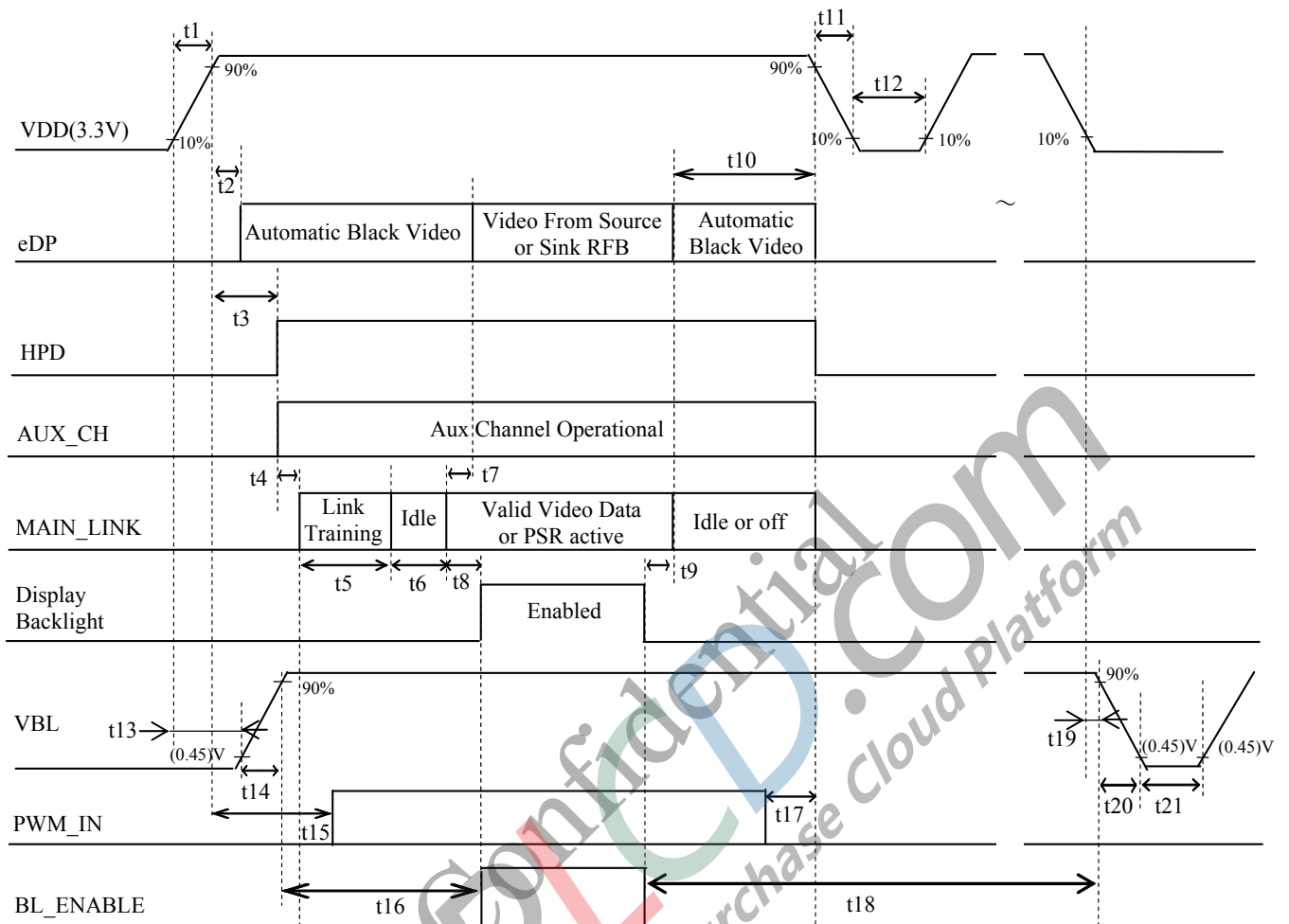

[Note] Do not keep the interface signal high-impedance or unusual signal when power is on.

Symbol	Min	Max	Unit	Note
t1	0.5	10	ms	
t2	0	200	ms	
t3	0	100	ms	
(t4)	-	-	ms	allows for the source to read link capability and initialize
(t5)	-	-	ms	[Note 3]
(t6)	-	-	ms	[Note 3]
(t7)	0	50	ms	
(t8)	-	-	ms	[Note 4]
(t9)	-	-	ms	[Note 5]
t10	0	500	ms	
t11	10	50	ms	[Note 1]
t12	500	-	ms	[Note 2] $\Delta 1$
(t13)	-	-	ms	[Note 6]
t14	0.1	10	ms	
t15	100	-	ms	
(t16)	0	-	ms	[Note 7]
t17	0	-	ms	
(t18)	0	-	-	[Note 7]
t19	-	-	ms	
t20	0.1	-	ms	
t21	100	-	ms	

[Note 1] As for the power off sequence for VDD (t11), Be sure to keep above mentioned timing.

If the VDD power off sequence timing is other than shown above, LCD may cause permanent damage.

As for the power sequence for backlight, it is recommended to apply above mentioned input timing.

If the backlight is light on and off at a timing other than shown above, displaying image may get disturbed.

[Note 2] As for the power off-on sequence for VDD(t12), be sure to keep above mentioned timing.

If the VDD power off-on sequence timing is other than shown above, LCD may cause permanent damage.

[Note 3] Dependant on the Source Link training protocol and Link idle.

[Note 4] The Source must assure display video is stable.

[Note 5] The Source must assure backlight is no longer illuminated.

[Note 6] Even if VBL Power is on earlier than VDD, It is not have any problem.

[Note 7] Prohibit the BL_ENABLE input of the period when it is not VBL Power on.

VDD-dip conditions

- 1) $2.5\text{ V} \leq \text{VDD} < 3.0\text{ V}$

$$t_d \leq 10\text{ ms}$$

Under above condition, the display image should return to an appropriate figure after VDD voltage recovers.

- 2) $\text{VDD} < 2.5\text{ V}$

VDD-dip conditions should also follow the ON-OFF conditions for supply voltage

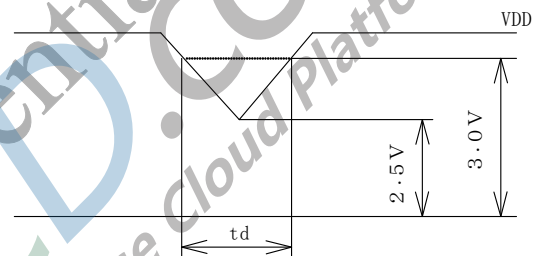

[Note 6-1-2] Typical current/power condition: 32*32 mosaic pattern.

$$\text{VDD} = +3.3\text{ V}$$

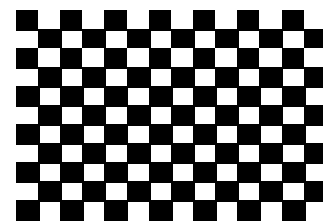

Maximum current/power condition: Purple/Green Stripe pattern

$$\text{VDD} = +3.3\text{ V}$$

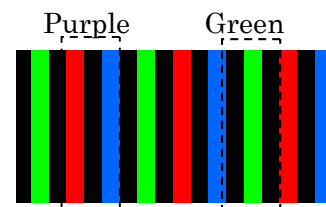

6 - 2. Backlight driving

The backlight system is an edge-lighting type with white-LED.

(It is usually required to measure under the following condition. : $T_a=25^{\circ}\text{C} \pm 2^{\circ}\text{C}$)

Parameter	Symbol	Min.	Typ.	Max	Unit	Remark
Supply voltage	VBL	5.0	12.0	21.0	V	
Power consumption	I_{BL}	—	2.64	2.91	W	VBL = 12.0V Duty Ratio=100%
Modulated light signal voltage	VPWMH	2.0	—	—	V	
	VPWML	0	—	0.8	V	
Brightness Control Duty Ratio	Duty	1	—	100	%	【Note6-2-1】
Brightness Control pulse width	T_{PWM}	5	—	—	us	【Note6-2-2】
Brightness Control frequency	f_{PWM}	200	-	2000	Hz	
LED-BL ON/OFF High voltage	VCNTH	2.0	3.3	3.6	V	【Note6-2-3】
LED-BL ON/OFF Low voltage	VCNTL	—	—	0.5	V	【Note6-2-3】
Input signal pin current	I_{IN}	—	—	1	μA	BL_ENABLE, BL_PWM_DIM
LED lifetime	-	—	15,000	—	h	LED

【Note6-2-1】 PWM_IN Input : 100%= Max luminance 1%= Min luminance

【Note6-2-2】 The minimum value of the dimming signal pulse width is assumed regulations of the width of high and the width of low.

【Note6-2-3】 BL_ENABLE Input : High = BL turn on, Low or OPEN = BL turn off

VBL-dip conditions

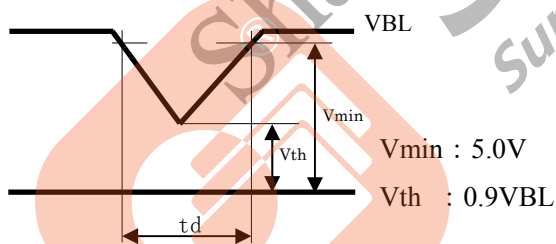

$$1) V_{th} \leq V_{BL} < V_{min} : t_d \leq 20\text{ms}$$

2) $V_{BL} < V_{th}$: The condition of instantaneous voltage drop is apply to input voltage sequences

7. Timing Characteristics of Input Signals

7 - 1. Timing characteristics

VDD=+3.0V~+3.6V, Ta=0°C~+50°C

Parameter		Symbol	Min.	Typ.	Max.	Unit	Remark
Clock	Frequency	1/Tc	—	241.5	—	MHz	[Note 7-1-1]
Data enable Signal	Horizontal period	TH	—	2720	—	clock	
				11.263		μs	
	Horizontal period (High)	THd	—	2560	—	clock	
	Vertical period	TV	—	1481	—	Line	
				16.68		ms	
Vertical period (High)	TVd	—	1440	—	line		

[Note 7-1-1] In case of using the long vertical period, the deterioration of display quality, flicker, etc, may occur.

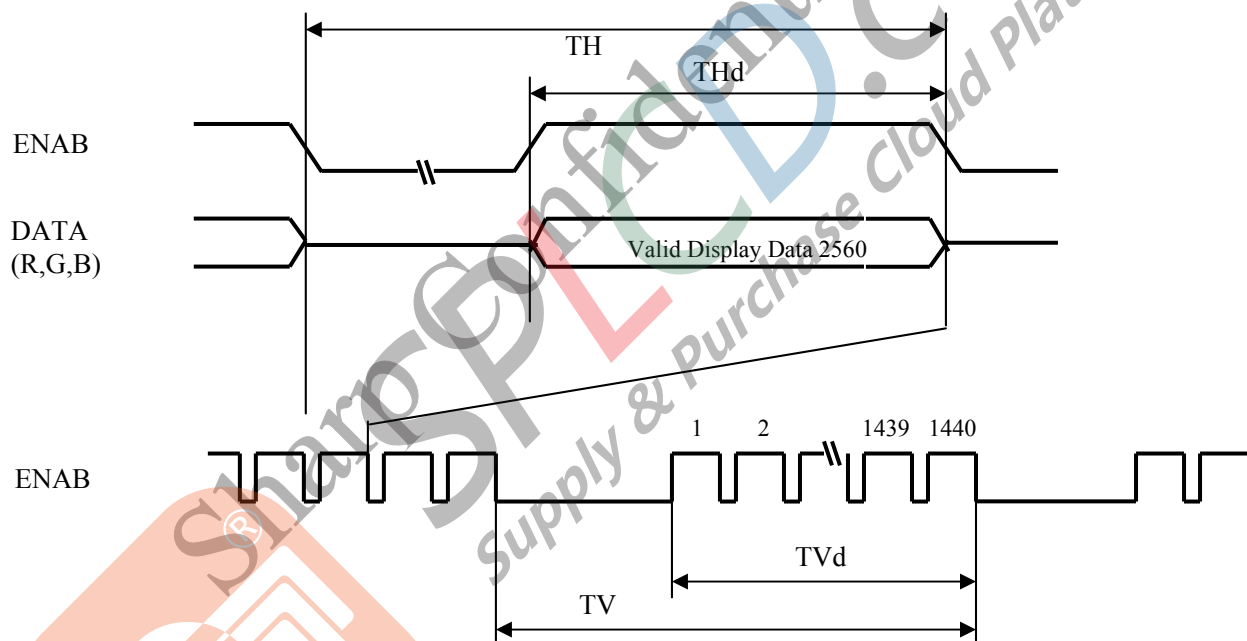

7 - 2. Input data signals and display position on the screen

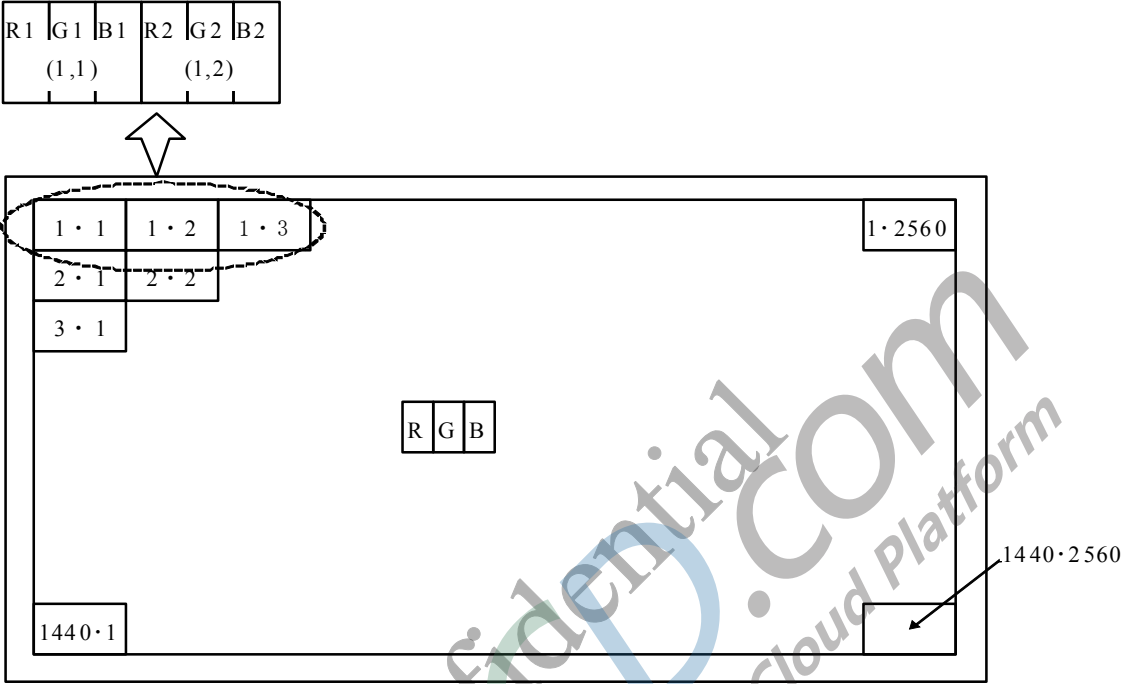

Display position of input data(V · H)

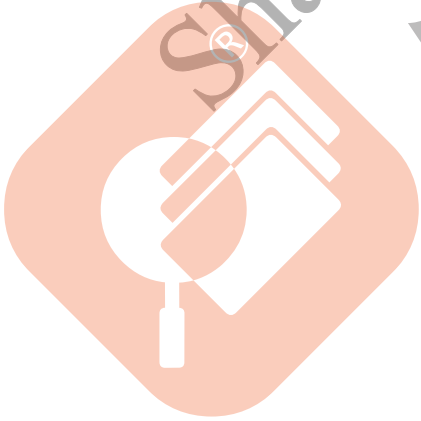

8. Input Signals, Basic Display Colors and Gray Scale of Each Color

Colors & Gray Scale	Data signal																																									
	Gray Scale	R0	R1	R2	R3	R4	R5	R6	R7	G0	G1	G2	G3	G4	G5	G6	G7	B0	B1	B2	B3	B4	B5	B6	B7																	
		LSB							MSB							LSB							MSB							LSB							MSB					
Basic Color	Black	—	0	0	0	0	0	0	0	0	0	0	0	0	0	0	0	0	0	0	0	0	0	0	0																	
	Blue	—	0	0	0	0	0	0	0	0	0	0	0	0	0	0	0	0	1	1	1	1	1	1	1																	
	Green	—	0	0	0	0	0	0	0	0	1	1	1	1	1	1	1	1	0	0	0	0	0	0	0																	
	Cyan	—	0	0	0	0	0	0	0	0	1	1	1	1	1	1	1	1	1	1	1	1	1	1	1																	
	Red	—	1	1	1	1	1	1	1	1	0	0	0	0	0	0	0	0	0	0	0	0	0	0	0																	
	Magenta	—	1	1	1	1	1	1	1	1	0	0	0	0	0	0	0	0	1	1	1	1	1	1	1																	
	Yellow	—	1	1	1	1	1	1	1	1	1	1	1	1	1	1	1	1	0	0	0	0	0	0	0																	
	White	—	1	1	1	1	1	1	1	1	1	1	1	1	1	1	1	1	1	1	1	1	1	1	1																	
Gray Scale of Red	Black	GS0	0	0	0	0	0	0	0	0	0	0	0	0	0	0	0	0	0	0	0	0	0	0																		
	↑	GS1	1	0	0	0	0	0	0	0	0	0	0	0	0	0	0	0	0	0	0	0	0	0																		
	Darker	GS2	0	1	0	0	0	0	0	0	0	0	0	0	0	0	0	0	0	0	0	0	0	0																		
	↑	↓	↓							↓							↓																									
	↓	↓	↓							↓							↓																									
	Brighter	GS253	1	0	1	1	1	1	1	1	0	0	0	0	0	0	0	0	0	0	0	0	0	0	0																	
	↓	GS254	0	1	1	1	1	1	1	1	0	0	0	0	0	0	0	0	0	0	0	0	0	0	0																	
	Red	GS255	1	1	1	1	1	1	1	1	0	0	0	0	0	0	0	0	0	0	0	0	0	0	0																	
Gray Scale of Green	Black	GS0	0	0	0	0	0	0	0	0	0	0	0	0	0	0	0	0	0	0	0	0	0	0																		
	↑	GS1	0	0	0	0	0	0	0	0	1	0	0	0	0	0	0	0	0	0	0	0	0	0																		
	Darker	GS2	0	0	0	0	0	0	0	0	1	0	0	0	0	0	0	0	0	0	0	0	0	0																		
	↑	↓	↓							↓							↓																									
	↓	↓	↓							↓							↓																									
	Brighter	GS253	0	0	0	0	0	0	0	0	1	0	1	1	1	1	1	1	0	0	0	0	0	0	0																	
	↓	GS254	0	0	0	0	0	0	0	0	0	1	1	1	1	1	1	1	0	0	0	0	0	0	0																	
	Green	GS255	0	0	0	0	0	0	0	0	1	1	1	1	1	1	1	1	0	0	0	0	0	0	0																	
Gray Scale of Blue	Black	GS0	0	0	0	0	0	0	0	0	0	0	0	0	0	0	0	0	0	0	0	0	0	0																		
	↑	GS1	0	0	0	0	0	0	0	0	0	0	0	0	0	0	0	0	1	0	0	0	0	0	0																	
	Darker	GS2	0	0	0	0	0	0	0	0	0	0	0	0	0	0	0	0	0	1	0	0	0	0	0																	
	↑	↓	↓							↓							↓																									
	↓	↓	↓							↓							↓																									
	Brighter	GS253	0	0	0	0	0	0	0	0	0	0	0	0	0	0	0	0	1	0	1	1	1	1	1																	
	↓	GS254	0	0	0	0	0	0	0	0	0	0	0	0	0	0	0	0	0	1	1	1	1	1	1																	
	Blue	GS255	0	0	0	0	0	0	0	0	0	0	0	0	0	0	0	0	1	1	1	1	1	1	1																	

0 : Low level voltage, 1 : High level voltage

Each basic color can be displayed in 256 gray scales from 8 bit data signals.

According to the combination of 24 bit data signals, the 16.7M color display can be achieved on the screen.

9. EDID Specifications

9 - 1. EDID data structure

This is the EDID(Extended Display Identification Data) data formats to support displays as defined in the VESA Plug & Display

Byte (decimal)	Byte (hex)	Field Name and Comments	Value (hex)	Value (binary)
0	00	Header	00	00000000
1	01	Header	FF	11111111
2	02	Header	FF	11111111
3	03	Header	FF	11111111
4	04	Header	FF	11111111
5	05	Header	FF	11111111
6	06	Header	FF	11111111
7	07	Header	00	00000000
8	08	EISA manufacture code = SHP	4D	01001101
9	09	EISA manufacture code (Compressed ASCII)	10	00010000
10	0A	Product code (LQ125T1JW02 : 5167)	2F	00101111
11	0B	Product code (hex,LSB first)	14	00010100
12	0C	LCD module Serial No (fixed "0")	00	00000000
13	0D	LCD module Serial No (fixed "0")	00	00000000
14	0E	LCD module Serial No (fixed "0")	00	00000000
15	0F	LCD module Serial No (fixed "0")	00	00000000
16	10	Week of manufacture	2D	00101101
17	11	Year of manufacture - 1990 (ex 2000 - 1990 = 10)	18	00011000
18	12	EDID structure version # = 1	01	00000001
19	13	EDID revision # = 4	04	00000100
20	14	Video i/p definition = Digital 8bit DP support	A5	10100101
21	15	Max H image size(cm) = 28cm	1C	00011100
22	16	Max V image size(cm) = 16cm	10	00010000
23	17	Display gamma (2.2×100) - 100 = 120	78	01111000
24	18	Feature support(stanby,suspend,RGB color/Prefer Time)	06	00000110
25	19	Red/Green Low bit(RxRy/GxGy)	DE	11011110
26	1A	Blue/White Low bit(BxBy/WxWy)	50	01010000
27	1B	Red X(Rx) (written value 0.64)	A3	10100011
28	1C	Red Y(Ry) (written value 0.33)	54	01010100
29	1D	Green X(Gx) (written value 0.3)	4C	01001100
30	1E	Green Y(Gy) (written value 0.6)	99	10011001
31	1F	Blue X(Bx) (written value 0.15)	26	00100110

Byte	Byte	Field Name and Comments	Value	Value
(decimal)	(hex)		(hex)	(binary)
32	20	Blue Y(By) (written value 0.06)	0F	00001111
33	21	White X(Wx) (written value 0.313)	50	01010000
34	22	White Y(Wy) (written value 0.329)	54	01010100
35	23	Established timings 1	00	00000000
36	24	Established timings 2	00	00000000
37	25	Established timings 3(Manufacture's reserved timing)	00	00000000
38	26	Standard timing ID1	01	00000001
39	27	Standard timing ID1	01	00000001
40	28	Standard timing ID2	01	00000001
41	29	Standard timing ID2	01	00000001
42	2A	Standard timing ID3	01	00000001
43	2B	Standard timing ID3	01	00000001
44	2C	Standard timing ID4	01	00000001
45	2D	Standard timing ID4	01	00000001
46	2E	Standard timing ID5	01	00000001
47	2F	Standard timing ID5	01	00000001
48	30	Standard timing ID6	01	00000001
49	31	Standard timing ID6	01	00000001
50	32	Standard timing ID7	01	00000001
51	33	Standard timing ID7	01	00000001
52	34	Standard timing ID8	01	00000001
53	35	Standard timing ID8	01	00000001
54	36	Detailed timing descriptor#1 fck/10000 (=241.5MHz/10000=24150=5E56h)	56	01010110
55	37	#1 fck	5E	01011110
56	38	#1 Horizontal active 2560=A00h 00h	00	00000000
57	39	#1 Horizontal blanking 160=0A0h A0h	A0	10100000
58	3A	#1 Horizontal active/Horizontal blanking A0h	A0	10100000
59	3B	#1 Vertical active 1440=5A0h A0h	A0	10100000
60	3C	#1 Vertical blanking 41=029h 29h	29	00101001
61	3D	#1 Vertical active/Vertical blanking 50h	50	01010000
62	3E	#1 Horizontal sync , offset(Thfp) 48=030h 30h	30	00110000
63	3F	#1 Horizontal sync , width 32=020h 20h	20	00100000

Byte (decimal)	Byte (hex)	Field Name and Comments	Value (hex)	Value (binary)
64	40	#1 Vertical sync,offset / Vertical sync,width (offset=3h/width=5h)	35	00110101
65	41	#1 Horizontal sync offset/width/Vertical sync offset/width	00	00000000
66	42	#1 Horizontal image size 276.5mm=115h 15h	15	00010101
67	43	#1 Vertical image size 155mm=09Bh 9Bh	9B	10011011
68	44	#1 Horizontal image size / Vertical image size 10h	10	00010000
69	45	Horizontal boader	00	00000000
70	46	Vertical boader	00	00000000
71	47	Flags(Non-interlaced=0/non 3D=00 / Digital separate=11/Horizontal polarity/Vertical polarity=00)	18	00011000
72	48	Detailed timing descriptor#1 fck/10000 (=161MHz/10000=16100=3EE4h) Δ1	Δ1 E4	11100100
73	49	#2 fck	Δ1 3E	00111110
74	4A	#2 Horizontal active 2560=A00h 00h	00	00000000
75	4B	#2 Horizontal blanking 160=0A0h A0h	A0	10100000
76	4C	#2 Horizontal active/Horizontal blanking A0h	A0	10100000
77	4D	#2 Vertical active 1440=5A0h A0h	A0	10100000
78	4E	#2 Vertical blanking 41=029h 29h	Δ1 29	00101001
79	4F	#2 Vertical active/Vertical blanking 50h	Δ1 50	01010000
80	50	#2 Horizontal sync , offset(Thip) 48=030h 30h	30	00110000
81	51	#2 Horizontal sync , width 32=020h 20h	20	00100000
82	52	#2 Vertical sync,offset / Vertical sync,width (offset=3h/width=5h)	Δ1 35	00110101
83	53	#2 Horizontal sync offset/width/Vertical sync offset/width	Δ1 00	00000000
84	54	#2 Horizontal image size 276.5mm=115h 15h	15	00010101
85	55	#2 Vertical image size 155mm=09Bh 9Bh	9B	10011011
86	56	#2 Horizontal image size / Vertical image size 10h	10	00010000
87	57	Horizontal boader	00	00000000
88	58	Vertical boader	00	00000000
89	59	Flags(Non-interlaced=0/non 3D=00/Degital separate=11/Horizontal polarity/Vertical polarity=00)	18	00011000
90	5A	Detailed timing descriptor #3	00	00000000
91	5B	Flag	00	00000000
92	5C	Reserved	00	00000000
93	5D	Dummy Descriptor	10	00010000
94	5E	Flag	00	00000000
95	5F	1st Dummy	00	00000000

Byte	Byte	Field Name and Comments	Value	Value
(decimal)	(hex)		(hex)	(binary)
96	60	2nd Dummy	00	00000000
97	61	3rd Dummy	00	00000000
98	62	4th Dummy	00	00000000
99	63	5th Dummy	00	00000000
100	64	6th Dummy	00	00000000
101	65	7th Dummy	00	00000000
102	66	8th Dummy	00	00000000
103	67	9th Dummy	00	00000000
104	68	10th Dummy	00	00000000
105	69	11th Dummy	00	00000000
106	6A	New line character #3 indicates end	00	00000000
107	6B	Padding with "blank" character	00	00000000
108	6C	Detailed timing descriptor #4	00	00000000
109	6D	Flag	00	00000000
110	6E	Reserved	00	00000000
111	6F	For Brightness Table and Power consumption	02	00000010
112	70	Flag	00	00000000
113	71	Supplier P/N#1 (L)	0A	00001010
114	72	Supplier P/N#2 (Q)	2B	00101011
115	73	Supplier P/N#3 (1)	FF	11111111
116	74	Supplier P/N#4 (2)	0F	00001111
117	75	Supplier P/N#5 (5)	3C	00111100
118	76	Supplier P/N#6 (T)	AD	10101101
119	77	Supplier P/N#7 (1)	1B	00011011
120	78	Supplier P/N#8 (J)	0B	00001011
121	79	Supplier P/N#9 (W)	20	00100000
122	7A	Supplier P/N#10 (0)	AD	10101101
123	7B	Supplier P/N#11 (2)	00	00000000
124	7C	Supplier P/N#12 ("Space")	00	00000000
125	7D	(If<13 char,then terminate with ASCII code 0Ah,set remaining char 20h)	00	00000000
126	7E	Extension flag	00	00000000
127	7F	Checksum	$\Delta 1$ 67	01100111

10. Optical Characteristics

Ta=+25°C, VDD=+3.3V

Parameter		Symbol	Condition	Min.	Typ.	Max.	Unit	Remark
Viewing angle range	Horizontal	$\theta 21, \theta 22$	CR>10	-	89	-	deg.	[Note 9-1, 9-3, 9-4, 9-6]
	Vertical	$\theta 11$		-	89	-	deg.	
		$\theta 12$		-	89	-	deg.	
Contrast ratio		CR	$\theta = 0^\circ$	700	1000	-		[Note 9-2, 9-4, 9-6]
Response time		$\tau r + \tau d$	$\theta = 0^\circ$	-	25	-	ms	[Note 9-2, 9-5, 9-6]
Chromaticity of white		x		0.283	0.313	0.343		[Note 9-2, 9-6]
		y		0.299	0.329	0.359		Normal operation (PWM Duty = 100%)
NTSC ratio				-	72	-	%	
Luminance of white		Y_{L1}		280	340	-	cd/m ²	[Note 9-2, 9-6] (PWM Duty = 100%)
White Uniformity 13pt		δ_w	$\theta = 0^\circ$	-	1.4	1.6		[Note 9-2, 9-7]

※ The measurement shall be taken 30 minutes after lighting the module at the following rating:

Condition: PWM Duty = 100%

The optical characteristics shall be measured in a dark room or equivalent.

[Note 9-1] Measurement of viewing angle range and Response time.

[Note 9-2] Measurement of luminance and Chromaticity and Contrast.

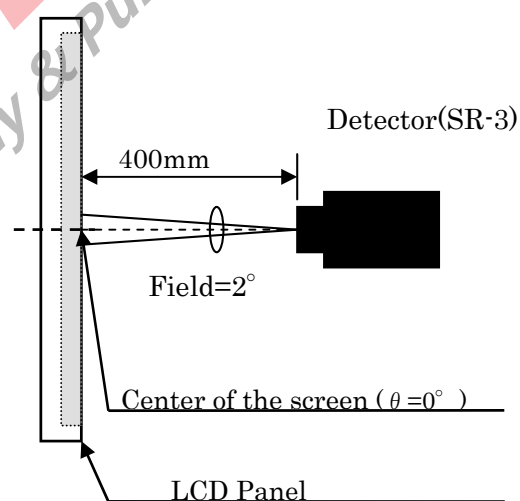
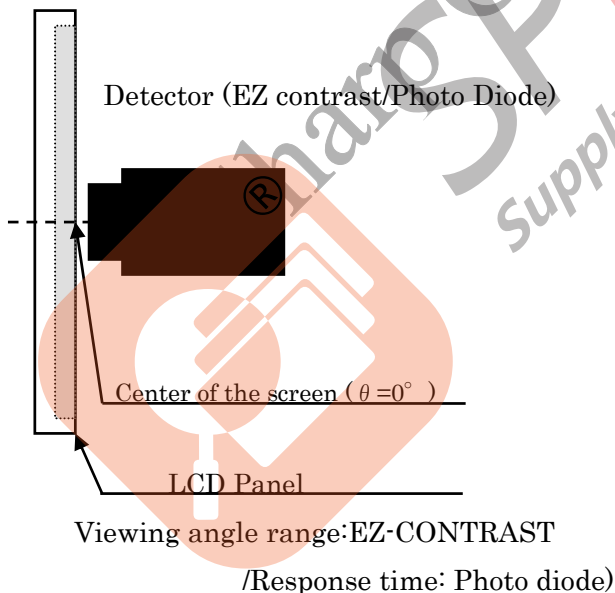

[Note 9-3] Definitions of viewing angle range:

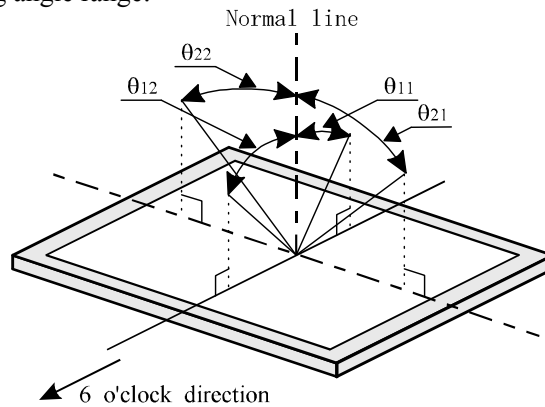

[Note 9-4] Definition of contrast ratio:

The contrast ratio is defined as the following.

$$\text{Contrast Ratio (CR)} = \frac{\text{Luminance (brightness) with all pixels white}}{\text{Luminance (brightness) with all pixels black}}$$

[Note 9-5] Definition of response time:

The response time is defined as the following figure and shall be measured by switching the input signal for "black" and "white" .

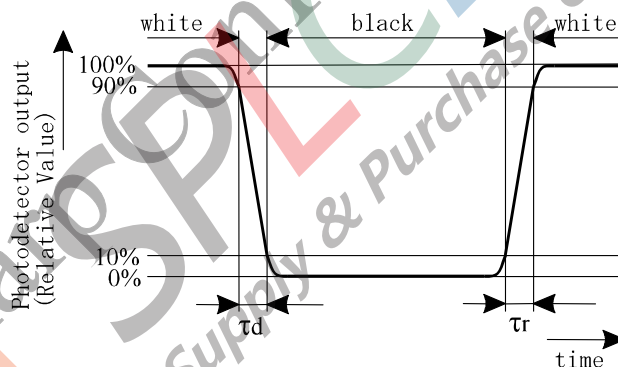

[Note 9-6] This shall be measured at center of the screen.

[Note 9-7] Definition of white uniformity:

White uniformity is defined as the following with five measurements (A~M).

$$\delta w = \frac{\text{Maximum Luminance of 13 points (brightness)}}{\text{Minimum Luminance of 13 points (brightness)}}$$

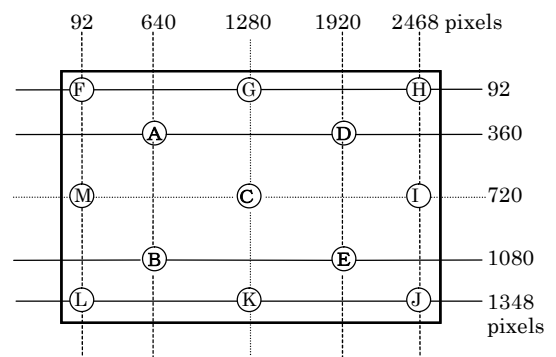

11. Display Quality

The display quality of the color TFT-LCD module shall be in compliance with the Incoming Inspection Standard.

12. About Handling

12.-1 Handling Precautions

- a) Be sure to turn off the power supply when inserting or disconnecting the cable.
Please insert for too much stress not to join a connector in the case of insertion of a connector.
- b) Be sure to design the cabinet so that the module can be installed without any extra stress such as warp or twist.
- c) Since the front polarizer is easily damaged, pay attention not to scratch it.
- d) Wipe off water drop immediately. Long contact with water may cause discoloration or spots.
- e) When the panel surface is soiled, wipe it with absorbent cotton or other soft cloth.
- f) Since the panel is made of glass, it may break or crack if dropped or bumped on hard surface. Handle with care.
- g) Since CMOS LSI is used in this module, take care of static electricity and injure the human earth when handling. Observe all other precautionary requirements in handling components.
- h) This module has its circuitry PCBs on the side and should be handled carefully in order not to be stressed.
- i) Protect sheet(Laminate film) is attached to the module surface to prevent it from being scratched. Peel the sheet off slowly just before the use with strict attention to electrostatic charges. Ionized air shall be blown over during the action. Blow off the 'dust' on the polarizer by using an ionized nitrogen gun, etc. Working under the following environments is desirable.
 - All workers wear conductive shoes, conductive clothes, conductive fingerstalls and grounding belts without fail.
- j) The polarizer surface on the panel is treated with Anti Glare . In case of attaching protective board over the LCD, be careful about the optical interface fringe etc. which degrades display quality.
- k) Do not expose the LCD module to a direct sunlight, for a long period of time to protect the module from the ultra violet ray.
- l) When handling LCD modules and assembling them into cabinets, please be noted that long-term storage in the environment of oxidization or deoxidization gas and the use of such materials as reagent, solvent, adhesive, resin, etc. which generate these gasses, may cause corrosion and discoloration of the LCD modules.
- m) Liquid crystal contained in the panel may leak if the LCD is broken. Rinse it as soon as possible if it gets inside your eye or mouth by mistake.
- n) Disassembling the module can cause permanent damage and should be strictly avoided.
Please don't remove the fixed tape, insulating tape etc that was pasted on the original module.
(Except for protection film of the panel.)
- o) Be careful when using it for long time with fixed pattern display as it may cause afterimage.
(Please use a screen saver etc., in order to avoid an afterimage.)
- p) If a minute particle enters in the module and adheres to an optical material, it may cause display non-uniformity issue, etc. Therefore, fine-pitch filters have to be installed to cooling and inhalation hole if you intend to install a fan.
- q) Epoxy resin (amine series curing agent), silicone adhesive material (dealcoholization series and oxime series), tray forming agent (azo compound) etc, in the cabinet or the packing materials may induce abnormal display with polarizer film deterioration regardless of contact or noncontact to polarizer film.
Be sure to confirm the component of them.
- r) Do not use polychloroprene. If you use it, there is some possibility of generating Cl₂ gas that influences the reliability of the connection between LCD panel and driver IC.

- s) Do not put a laminate film on LCD module, after peeling of the original one. If you put on it, it may cause discoloration or spots because of the occurrence of air gaps between the polarizer and the film.
- t) Ground module bezel to stabilize against EMI and external noise.
- u) When you peel off the protection film,
- Be sure to peel off slowly (recommended more than 5sec) and constant speed.
 - Peeling direction shows the following Figure.
 - Be sure to ground person with adequate methods such as the anti-static wrist band.
 - Be sure to ground all terminals of the PWB connector while peeling of the protection film.
 - Ionized air should be blown over during peeling action.
 - The protection film must not touch driver-ICs, PWB and all components on PWB.
 - If adhesive may remain on the polarizer after the protection film peeling off, please remove with isopropyl-alcohol.

Front view

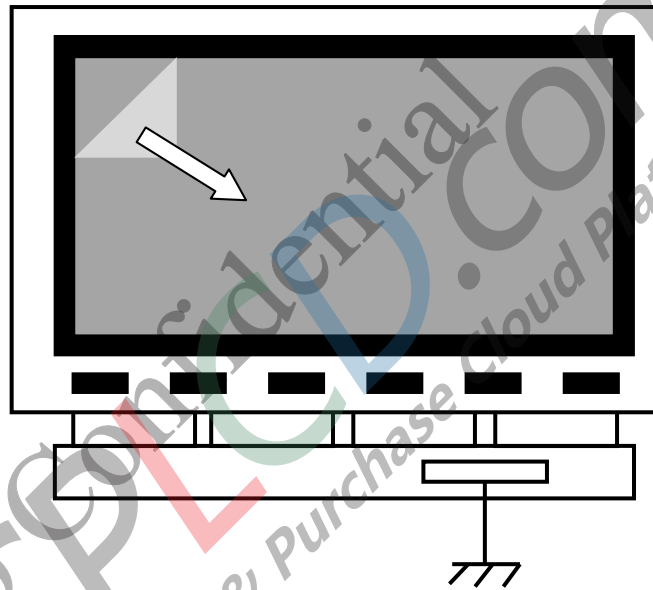

12.-2 Precautions for Handling Tray

- a.) Hold center of short side of tray with both hands when handling one or more trays.

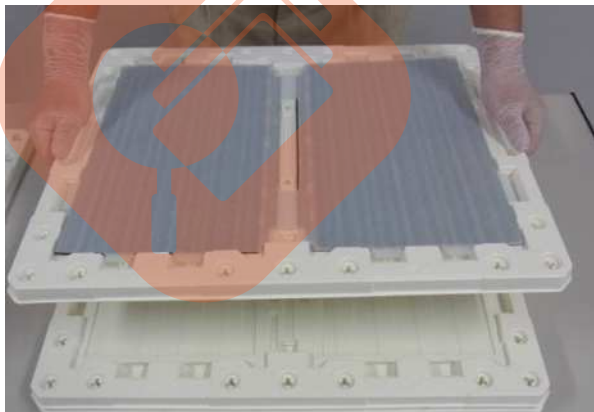

Caution : Do not handle with only one hand .



- b.) Always place tray on flat surface.
- c.) When stacking trays, please align same shape corner of each tray.
One corner is R corner. (Ref. Pic. 1)
- d.) Maximum stacking quantity is the number of trays inside one box.
Ex. : In case of 20pcs LCD module per box (2pcs LCD module per tray), maximum stacking is 10 trays.



R Corner

Pic.1 Stacking tray

13. Packaging Condition

Piling number of cartons	6
Package quantity in one carton	30 pcs
Carton size	534 x 394 x 240 mm
Total mass of one carton filled with full modules	10 kg
Packing form	Fig.1

14. Label △1

1) Module bar code label:

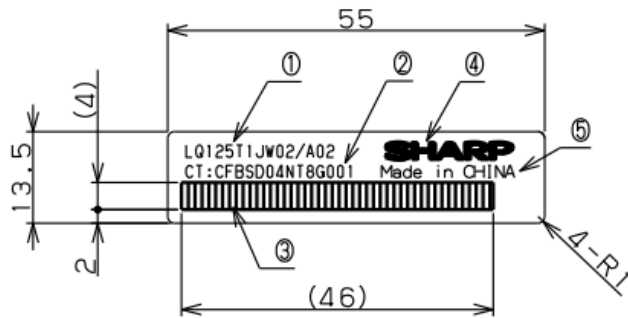

	font	notes
①: SHARP Model No	(8)	[LQ125T1JW02/A02]
②: Serial Number	(8)	
③: Barcode (Serial Number)	-	Barcode Symbology: Code93 Do not include the characters "CT:" within the barcode
④: SHARP Logo	-	data:sharplogo
⑤: Manufacturing Country	(8)	

②Serial Number

14digits

※There is no space between characters

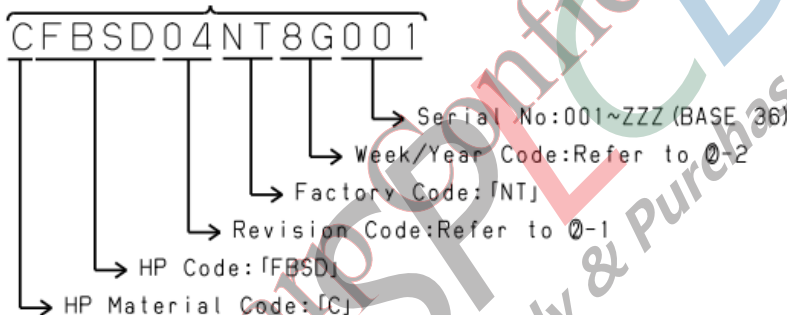

	HW code	CT rev code	Label
Start	A01	01	
ACF changed and AL tape changed(Right and Left side.)	A02	02	
PSR disable	A01	03	
ACF changed + AL tape + PSR disable	A02	04	

2) Packing bar code label

Notation/ Bar code: ①SHARP Model No. ②Date ③Quantity (30pcs / Carton) ④HP code

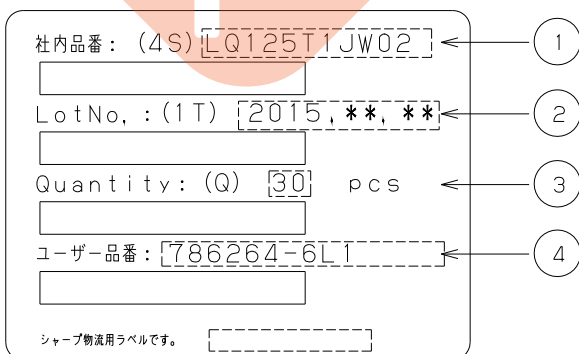

Tape : right and left side

	HP code
PET tape	786264-6L1
AL tape	786264-6L2

15. RoHS Directive

This LCD module is compliant with RoHS Directive.

16. Halogen Free

This LCD module is compliant with Halogen Free.

17. Reliability Test Item

No.	Test item	Conditions
1	High temperature storage test	Ta = 60°C 240h
2	Low temperature storage test	Ta = -20°C 240h
3	High temperature & high humidity operation test	Ta = 40°C ; 90%RH 240h (No condensation)
4	High temperature operation test	Ta = 50°C 240h
5	Low temperature operation test	Ta = 0°C 240h
6	Vibration test (non- operating)	Frequency:10~57Hz/Vibration width one side: 0.076mm:57~500Hz acceleration: 9.8m/s ² Sweep time: 11minutes Test period: 1 hour for each direction of X,Y,Z
7	Shock test (non- operating)	Max. gravity : 490 m/s ² Pulse width : 11 ms, half sine wave Direction : ±X, ±Y, ±Z once for each direction.
8	ESD	±200V, 200pF 0Ω 1time/each terminal

[Result Evaluation Criteria] Under the display quality test conditions with normal operation state.

Do not change these conditions as such changes may affect practical display function.

[Normal operation state] Temperature : +15~+35°C, Humidity : 45~75%, Atmospheric pressure : 86~106kPa

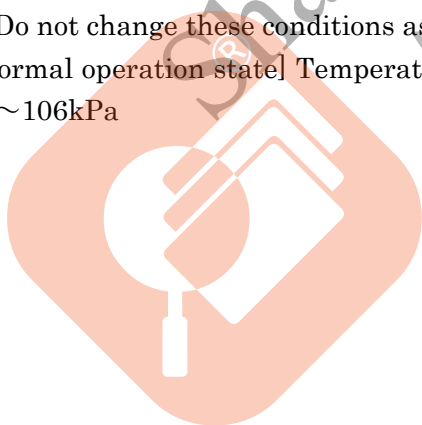

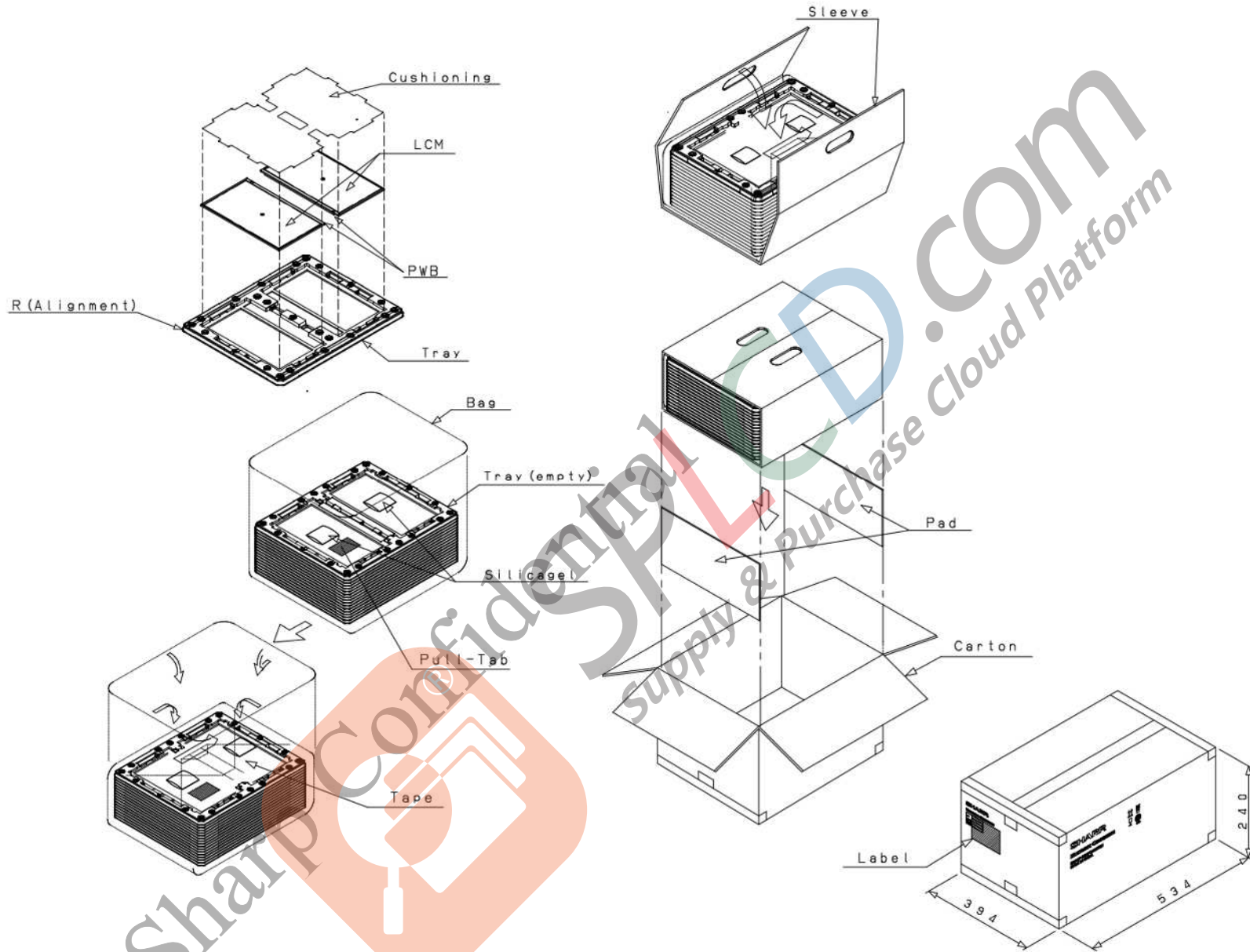

Fig. 1 Packaging Condition

