

**SHARP**

No.	LD-7752D
DATE	DECEMBER 22, 1995

TECHNICAL LITERATURE  
FOR  
TFT-LCD module

MODEL No. LQ12DX12

The technical literature is subject to change without notice.  
So, please contact Sharp or its representative before designing  
your product based on this literature.



T. UNO

Department General Manager of  
Engineering Dept. IV  
TFT Development Center  
Tenri Liquid Crystal Display Group  
Sharp Corporation

**REIN Components GmbH**

Lötscher Weg 66 · D-41334 Nettetal  
Telefon +49 (0)2153-733 91 · Telefax +49 (0)2153-733 575  
email rein@rnc.memec.com · <http://www.rein.memec.com>  
Hotline +49 (0)2153-733 112

A Specialist within the Memec International Components Group



Components

www.DataSheet.com

### 1. Application

This technical literature applies to color TFT-LCD module, LQ12DX12.

### 2. Overview

This module is a color active matrix LCD module incorporating amorphous silicon TFT (Thin Film Transistor). It is composed of a color TFT-LCD panel, driver ICs, control circuit, power supply circuit and a backlight unit. Graphics and texts can be displayed on a 1024x768 pixel panel in 262,144 colors by supplying 18(6xRGB)x2bit parallel data signals, four kinds of timing signals and supplying +5V DC supply voltages for TFT-LCD panel driving.

The TFT-LCD panel used for this model is a low-reflection and higher-color-saturation type. Therefore, this module is suitable for the multi-media use.

Backlight-driving DC/AC inverter is not built in this module.

### 3. Mechanical Specifications

Parameter	Specifications	Unit
Screen size	31 (Diagonal)	cm
	12.1(Diagonal)	inch
Effective display area	245.8(H)×184.3(V)	mm
Display pixels	1024(H)×768(V)	pixel
	(1 pixel=R+G+B dots)	—
Pixel pitch	0.24(H)×0.24(V)	mm
Pixel configuration	R,G,B vertical stripe	—
Display mode	Normally white	—
Outline dimension (TYP) $\text{mm}$	283(W)×215.6(H)×16.5(D)	mm
Weight	1070	g
Surface treatment	Anti-glare and hard-coating (2H)	

$\text{mm}$  NOTE: excluding backlight cables.

## 4. Input Terminals and function

## 4-1-a) TFT-LCD panel driving

CN1 (Interface signal and +5V power supply)

Using connector : IL-FPR-50S-HF(JAE)

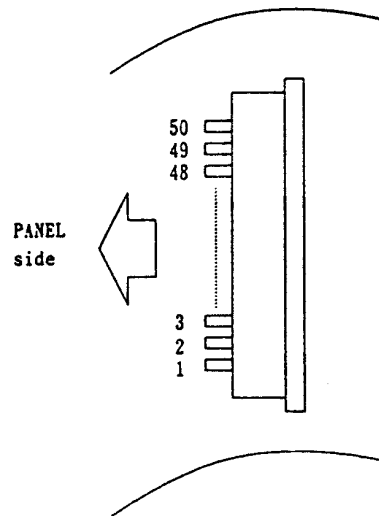

Pin No.	Symbol	Function
1	GND	-
2	R10	Red data signal of even pixels bit0
3	R11	Red data signal of even pixels bit1
4	R12	Red data signal of even pixels bit2
5	R13	Red data signal of even pixels bit3
6	R14	Red data signal of even pixels bit4
7	R15	Red data signal of even pixels bit5
8	G10	Green data signal of even pixels bit0
9	G11	Green data signal of even pixels bit1
10	G12	Green data signal of even pixels bit2
11	G13	Green data signal of even pixels bit3
12	G14	Green data signal of even pixels bit4
13	G15	Green data signal of even pixels bit5
14	B10	Blue data signal of even pixels bit0
15	B11	Blue data signal of even pixels bit1
16	B12	Blue data signal of even pixels bit2
17	B13	Blue data signal of even pixels bit3
18	B14	Blue data signal of even pixels bit4
19	B15	Blue data signal of even pixels bit5
20	GND	-

- continues on the next page -

Pin No.	Symbol	Function
21	R00	Red data signal of odd pixels bit0
22	R01	Red data signal of odd pixels bit1
23	R02	Red data signal of odd pixels bit2
24	R03	Red data signal of odd pixels bit3
25	R04	Red data signal of odd pixels bit4
26	R05	Red data signal of odd pixels bit5
27	G00	Green data signal of odd pixels bit0
28	G01	Green data signal of odd pixels bit1
29	G02	Green data signal of odd pixels bit2
30	G03	Green data signal of odd pixels bit3
31	G04	Green data signal of odd pixels bit4
32	G05	Green data signal of odd pixels bit5
33	B00	Blue data signal of odd pixels bit0
34	B01	Blue data signal of odd pixels bit1
35	B02	Blue data signal of odd pixels bit2
36	B03	Blue data signal of odd pixels bit3
37	B04	Blue data signal of odd pixels bit4
38	B05	Blue data signal of odd pixels bit5
39	GND	-
40	ENABLE	-
41	Vsync	Vertical sync signal(negative)
42	Hsync	Horizontal sync signal(negative)
43	GND	-
44	CKEV	Clock signal of even pixels
45	CKOD	Clock signal of odd pixels
46	GND	-
47	VCC	+5V power supply
48	VCC	+5V power supply
49	VCC	+5V power supply
50	VCC	+5V power supply

## 4-2) Backlight (twin CCFTs)

CNA Using connector: BHR-03VS-1 (JST)

Corresponding connector: SM02(8.0)B-BHS (JST)

Pin No.	Symbol	Function
1	V <sub>HIGH</sub>	Power supply for lamp (High voltage side)
2	NC	This is electrically opened.
3	V <sub>LOW</sub>	Power supply for lamp (Low voltage side)

\* Cable length: 65±5mm

## 5. Absolute Maximum Ratings

Parameter	Symbol	Condition	Ratings	Unit	Remark
Input voltage	V <sub>I</sub>	T <sub>a</sub> =25℃	-0.3 ~ V <sub>CC</sub> +0.3	V	-
+5V supply voltage	V <sub>CC</sub>	T <sub>a</sub> =25℃	-0.3 ~ +6	V	-
Storage temperature	T <sub>stg</sub>	-	-25 ~ +60	℃	【Note】
Operating temperature (Ambient temp.)	T <sub>opa</sub>	-	0 ~ +50	℃	-

【Note】 Relative humidity 95%RH Max. (at T<sub>a</sub>≤40℃)Maximum wet-bulb temperature 39℃ or less. (at T<sub>a</sub>>40℃)

No condensation.

## 6. Electrical Characteristics

## 6-1. Electrical Characteristics

## 6-1-a) TFT-LCD panel driving

T<sub>a</sub> = 25℃

Parameter		Symbol	Min.	Typ.	Max.	Unit	Remark
+5V	Supply voltage	V <sub>CC</sub>	+4.5	+5.0	+5.5	V	【Note1】
	Current dissipation	I <sub>CC</sub>	-	300	450	mA	【Note2】
Permissive input ripple voltage		V <sub>P-P</sub>	-	-	100	mV	V <sub>CC</sub>
Input threshold voltage	High	V <sub>TH</sub>	+2.4	-	V <sub>CC</sub>	V	-
	Low	V <sub>TL</sub>	GND	-	+1.0	V	-

**【Note1】**

Vcc-turn-on conditions

- $t_1 \leq 10 \text{ ms}$
- $0 < t_2 \leq 10 \text{ ms}$
- $0 < t_3 \leq 1 \text{ s}$

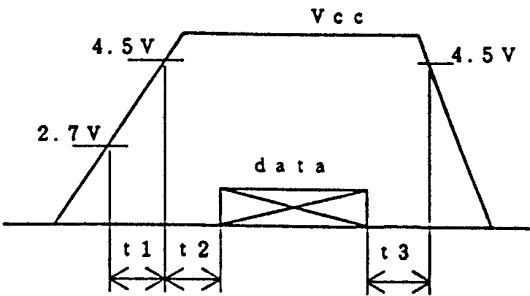

Vcc-dip conditions

- 1)  $2.7 \text{ V} \leq V_{cc} < 4.5 \text{ V}$
- $t_d \leq 10 \text{ ms}$

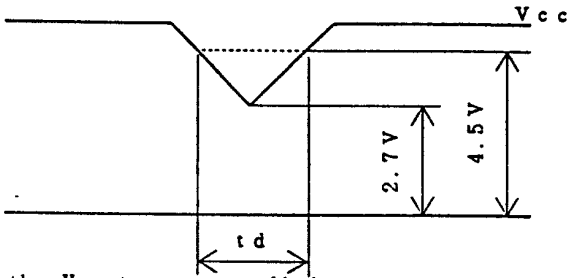

- 2)  $V_{cc} < 2.7 \text{ V}$

Vcc-dip conditions should also follow the Vcc-turn-on conditions.

※CAUTION : No Horizontal sync and Vertical sync signals must damage LCD panel permanently.

**【Note2】**

Typical current situation : (Vcc=+5V)

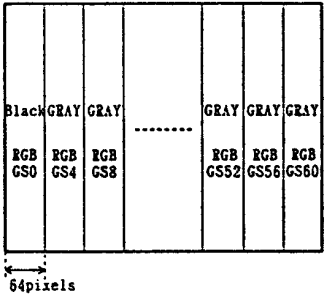

16-Gray-scale pattern

(Each RGB data:GSi is shown at 6-5.)

## 6-1-b) Backlight

The backlight system is an edge lighting type with twin CCFTs.

The characteristics of single lamp are shown in the following table.

$T_a = 25^\circ\text{C}$

Parameter	Symbol	Min.	Typ.	Max.	Unit	Remark
Lamp voltage	$V_L$	—	530	—	Vrms	【Note 1】
Lamp current	$I_L$	2.5	5.5	6.0	mArms	—
Lamp power consumption	$P_L$	—	2.9	—	W	【Note 2】
Frequency	$F_L$	30	40	50	KHz	【Note 3】
Kick-off voltage	$V_s$	—	—	1100	Vrms	$T_a = 25^\circ\text{C}$ 【Note 4】
		—	—	1400	Vrms	$T_a = 0^\circ\text{C}$
Lamp life time	$T_L$	10000	—	—	hour	【Note 5】

【Note 1】 Lamp current is measured with current meter for high frequency as shown below.

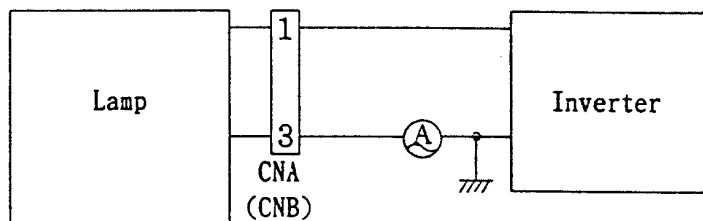

【Note 2】 Calculated values for reference. ( $I_L \times V_L$ )

【Note 3】 Lamp frequency may produce interference with horizontal sync. frequency, and interference may cause beat on the display. Therefore lamp frequency shall be as different as possible from that of horizontal sync signal to avoid interference.

【Note 4】 The open output voltage of the inverter shall be maintained for more than 1s; otherwise the lamp may not be turned on.

【Note 5】 Lamp life time is defined that it applied either ① or ② under this condition (continuous turning on at  $T_a = 25^\circ\text{C}$ ,  $I_L = 5.5$  mArms)

① Brightness becomes 50% of the original value under standard condition.

② Kick-off voltage at  $T_a = 0^\circ\text{C}$  exceeds maximum value, 1400 Vrms.

Note) The performance of the backlight, for example life time or brightness, is much influenced by the characteristics of DC-AC inverter for the lamp. When you design or order the inverter, please make sure that a poor lighting caused by the mismatch of the backlight and the inverter (miss-lighting, flicker, etc.) never occurred. When you confirm it, the module should be operated in the same condition as it is installed in your equipment.

## 6-2. Timing Characteristics of input signals

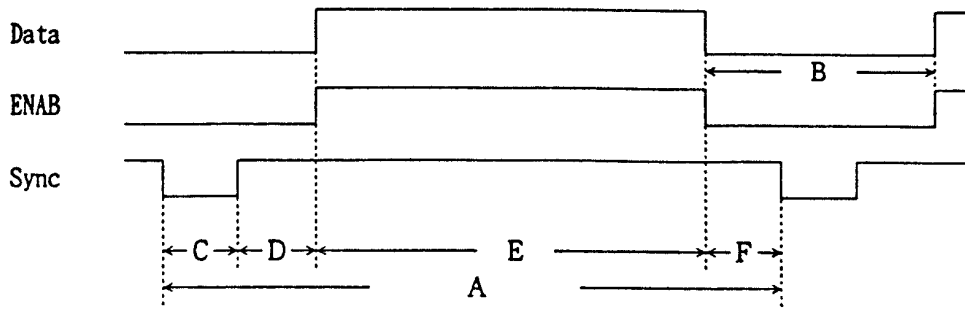

(Vertical)

Item (symbol)	Min.	Typ.	Max.	Unit	Remark
Vsync cycle( $T_{VA}$ )	—	16.666	—	ms	negative
	803	806	—	line	
Blanking period( $T_{VB}$ )	4	38	—	line	—
Sync pulse width( $T_{VC}$ )	4	6	—	line	—
Back porch( $T_{VD}$ )	0	29	—	line	—
Sync pulse width + Back porch ( $T_{VC}+T_{VD}$ )	35	35	35	line	—
Active display area( $T_{VE}$ )	768	768	768	line	—
Front porch( $T_{VF}$ )	0	3	—	line	—

(Horizontal)

Item (symbol)	Min.	Typ.	Max.	Unit	Remark
Hsync cycle( $T_{HA}$ )	19.2	20.677	—	$\mu$ s	negative
	520	672	—	clock	
Blanking period( $T_{HB}$ )	8	160	—	clock	—
Sync pulse width( $T_{HC}$ )	4	68	—	clock	—
Back porch( $T_{HD}$ )	0	80	—	clock	—
Active display area( $T_{HE}$ )	512	512	512	clock	—
Front porch( $T_{HF}$ )	4	12	—	clock	—

(Clock)

Item	Min.	Typ.	Max.	Unit	Remark
Frequency	25.0	32.5	35.0	MHz	【Note1】

【Note1】 Two pixel-data are sampled at a time.

(Hsync-Vsync Phase difference)

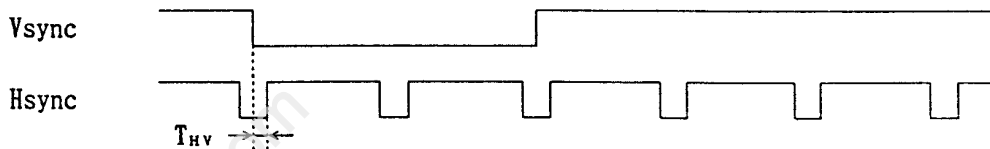

Item	Min.	Typ.	Max.	Unit	Remark
Hsync-Vsync Phase difference ( $T_{HV}$ )	1	—	$T_{HA}-T_{HC}$	clock	—



## (Hsync-ENAB Phase difference)

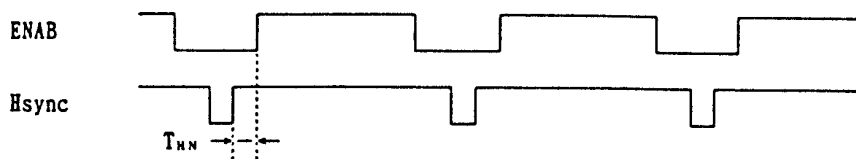

Item	Min.	Typ.	Max.	Unit	Remark
Hsync-ENAB Phase difference( $T_{HN}$ )	0	-	186	clock	-

## 6-3. Display position

Item	Standards	Beginning	Ending	Unit	Remark
Horizontal	rising edge of ENAB	0	512	clock	-
	falling edge of Hsync	148	660	clock	【Notel】
Vertical	falling edge of Vsync	35	803	line	-

【Notel】 ENAB signal must be fixed to low.

Note)

(Horizontal display direction)

When ENAB is fixed to low, 148 clocks are counted from Hsync falling edge and data from after are available. If you need other timing, please use ENAB signal.

(Vertical display directio)

35 lines are counted from Vsync falling edge and data from next line are available.

(Note of ENAB signal)

Do NOT use ENAB for positioning of the vertical display direction.

ENAB signal same as the display period must be input for the vertical blanking period.

Caution:

Image will not be displayed on the right position otherwise.

## 6-4. Input Signals and display position

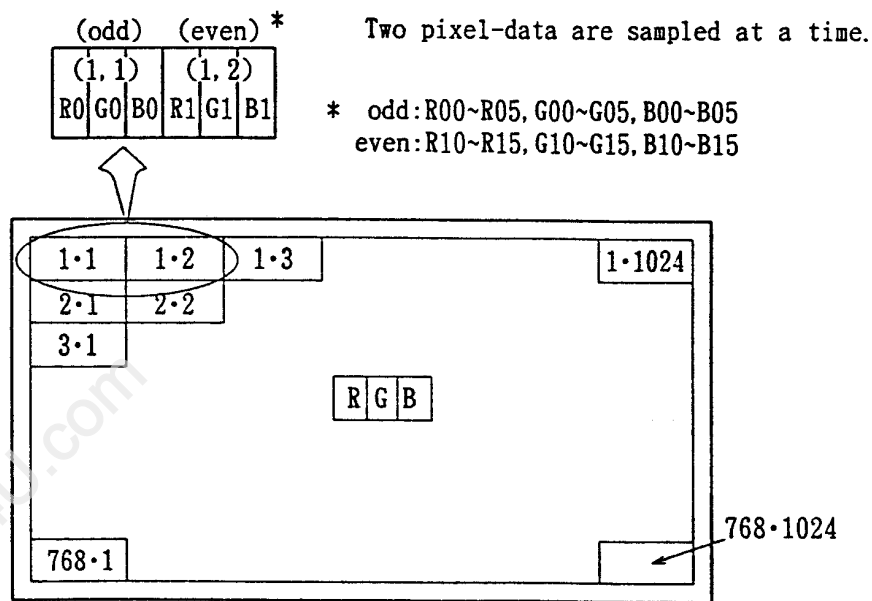

Display position of input data (V · H)

## 6-6. Timing characteristics of input signals

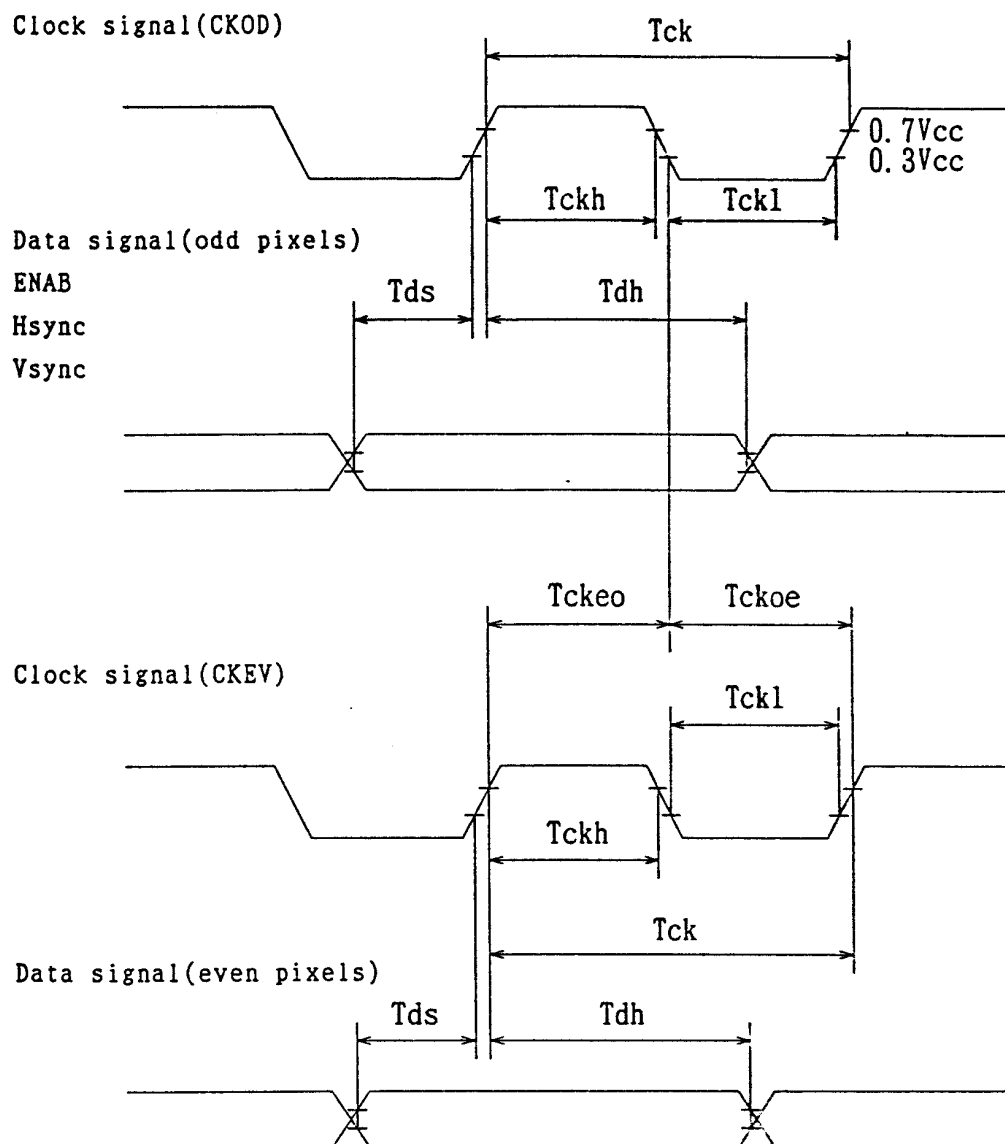

Parameter	Symbol	Min.	Typ.	Max.	Unit
Clock period	$T_{ck}$	26	30	40	ns
Clock high time	$T_{ckh}$	9	—	—	ns
Clock low time	$T_{ckl}$	12	—	—	ns
Data setup time	$T_{ds}$	8	—	—	ns
Data hold time	$T_{dh}$	5	—	—	ns
CKEV to CKOD time	$T_{ckeo}$	6	—	—	ns
CKOD to CKEV time	$T_{ckoe}$	6	—	—	ns

## 6-5. Input Signals, Basic Display Colors and Gray Scale of Each Color

	color & gray scale	Data signal																	
		odd						even						Data signal					
		R0	R1	R2	R3	R4	R5	G0	G1	G2	G3	G4	G5	B0	B1	B2	B3	B4	B5
Basic color	Black	0	0	0	0	0	0	0	0	0	0	0	0	0	0	0	0	0	0
	Blue	0	0	0	0	0	0	0	0	0	0	0	0	1	1	1	1	1	1
	Green	0	0	0	0	0	0	1	1	1	1	1	1	0	0	0	0	0	0
	Light blue	0	0	0	0	0	0	1	1	1	1	1	1	1	1	1	1	1	1
	Red	1	1	1	1	1	1	0	0	0	0	0	0	0	0	0	0	0	0
	Purple	1	1	1	1	1	1	0	0	0	0	0	0	1	1	1	1	1	1
	Yellow	1	1	1	1	1	1	1	1	1	1	1	1	0	0	0	0	0	0
	White	1	1	1	1	1	1	1	1	1	1	1	1	1	1	1	1	1	1
Gray Scale of Red	Black (GS0)	0	0	0	0	0	0	0	0	0	0	0	0	0	0	0	0	0	0
	↑ (GS1)	1	0	0	0	0	0	0	0	0	0	0	0	0	0	0	0	0	0
	Darker	0	1	0	0	0	0	0	0	0	0	0	0	0	0	0	0	0	0
	↑			↑				0	0	0	0	0	0	0	0	0	0	0	0
	↓			↓				0	0	0	0	0	0	0	0	0	0	0	0
	Brighter	1	0	1	1	1	1	0	0	0	0	0	0	0	0	0	0	0	0
	↓ (GS62)	0	1	1	1	1	1	0	0	0	0	0	0	0	0	0	0	0	0
Red (GS63)	1	1	1	1	1	1	0	0	0	0	0	0	0	0	0	0	0	0	
Gray Scale of Green	Black (GS0)	0	0	0	0	0	0	0	0	0	0	0	0	0	0	0	0	0	0
	↑ (GS1)	0	0	0	0	0	0	1	0	0	0	0	0	0	0	0	0	0	0
	Darker	0	0	0	0	0	0	0	1	0	0	0	0	0	0	0	0	0	0
	↑	0	0	0	0	0	0			↑			0	0	0	0	0	0	
	↓	0	0	0	0	0	0			↓			0	0	0	0	0	0	
	Brighter	0	0	0	0	0	0	1	0	1	1	1	1	0	0	0	0	0	0
	↓ (GS62)	0	0	0	0	0	0	0	1	1	1	1	1	0	0	0	0	0	0
Green (GS63)	0	0	0	0	0	0	1	1	1	1	1	1	0	0	0	0	0	0	
Gray Scale of Blue	Black (GS0)	0	0	0	0	0	0	0	0	0	0	0	0	0	0	0	0	0	0
	↑ (GS1)	0	0	0	0	0	0	0	0	0	0	0	0	1	0	0	0	0	0
	Darker	0	0	0	0	0	0	0	0	0	0	0	0	0	1	0	0	0	0
	↑	0	0	0	0	0	0	0	0	0	0	0	0			↑			
	↓	0	0	0	0	0	0	0	0	0	0	0	0			↓			
	Brighter	0	0	0	0	0	0	0	0	0	0	0	0	1	0	1	1	1	1
	↓ (GS62)	0	0	0	0	0	0	0	0	0	0	0	0	0	1	1	1	1	1
Blue (GS63)	0	0	0	0	0	0	0	0	0	0	0	0	1	1	1	1	1	1	

0: Low level voltage    1: High level voltage

Each color is displayed in 64 gray scales from 6 bit data signal input.  
According to the combination of total 18 bit data, 262,144 colors  
are displayed.

## 7. Optical Characteristics

Ta=25°C, Vcc=+5V

Parameter		Symbol	Condition	Min.	Typ.	Max.	Unit	Remark
Viewing angle range	Horizontal	$\theta 21, 22$	CR > 10	35	—	—	Deg.	【Note1】
	Vertical	$\theta 11$		10	—	—	Deg.	
		$\theta 12$		30	—	—	Deg.	
Contrast ratio		CR	$\theta = 0^\circ$	100	—	—		【Note2】
Response time	Rise	$\tau r$		—	30	—	ms	【Note3】
	Fall	$\tau f$		—	50	—	ms	
Luminance of white		$Y_L$		105	150	—	cd/m <sup>2</sup>	—
Chromaticity of white		X		—	0.290	—	—	—
		Y	—	0.320	—	—	—	
White uniformity		$\delta w$	—	—	1.25	—	【Note4】	

※ The measurement shall be executed after brightness of the backlight has reached its saturation point. ( $I_L=5.5$  mA rms)  
 The optical characteristics are measured in a darkroom or equivalent state with the method shown in Fig.3. And these characteristics except for White uniformity are measured at the center of the screen.

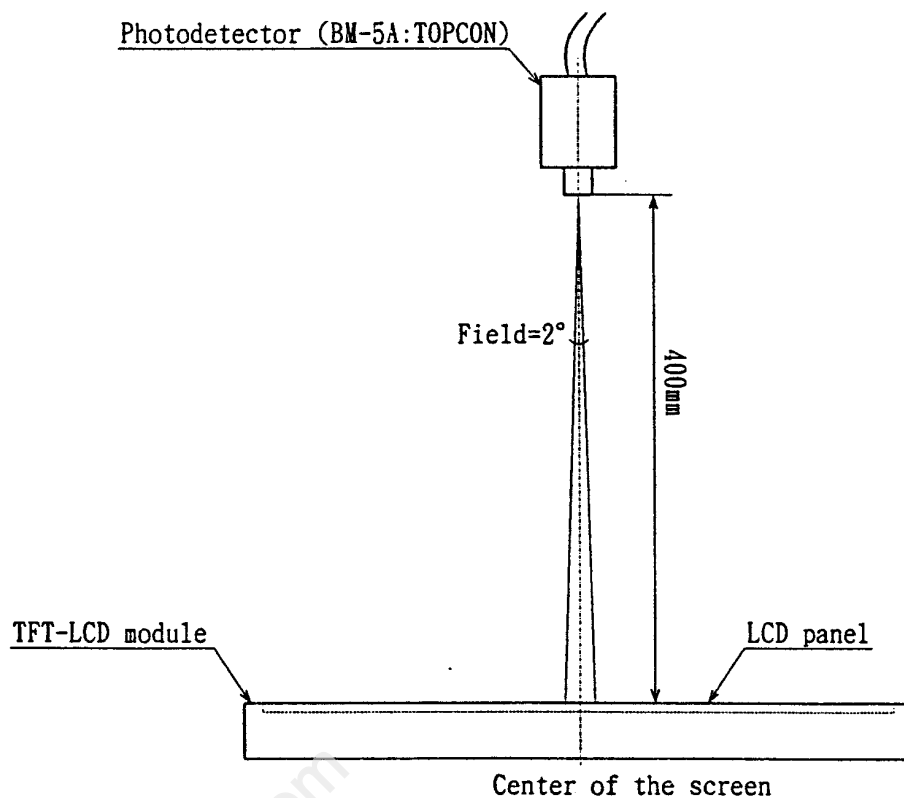
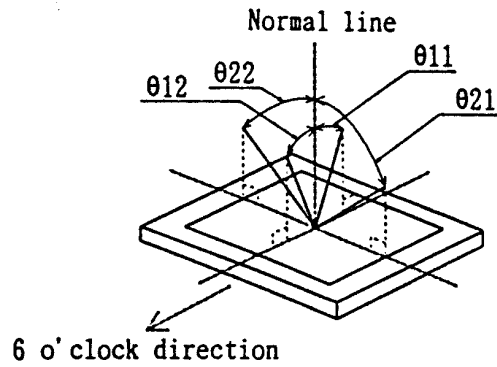

Fig. 3 Optical characteristics measurement method

【Note1】 Definitions of viewing angle:



【Note2】 Definitions of Contrast Ratio:

The contrast ratio is defined as follows.

$$\text{Contrast Ratio} = \frac{\text{Luminance (brightness) with all pixels white}}{\text{Luminance (brightness) with all pixels black}}$$

【Note3】 Definitions of Response Time:

The response time shall be measured as the following figure by switching the input signals for "black" ON and OFF.

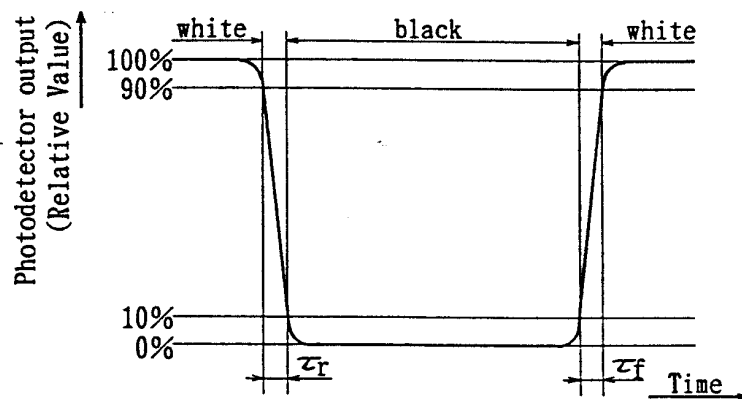

**【Note4】 Definition of White uniformity:**

The white uniformity is defined as the following equation among the values measured at the 5 spots(A~E).

$$\frac{\text{maximum luminance (brightness)}}{\text{minimum luminance (brightness)}}$$

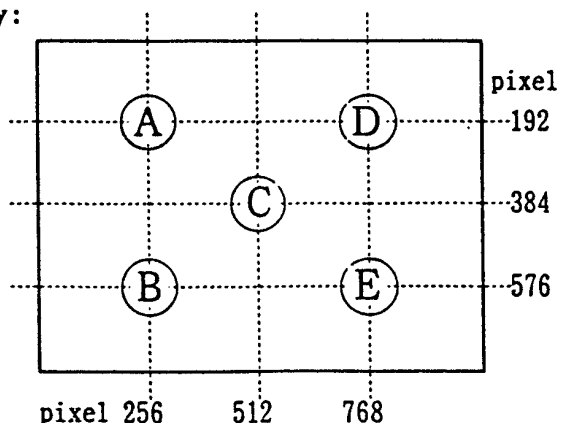
**8. Display quality**

The display quality of this module shall be in compliance with the Delivery Inspection Standard.

**9. Handling Precautions**

- 9-1) Be sure to insert the cable into the connector or take out of the connector after turning off the power supply on the set side.
- 9-2) Others
  - a) When installing the module, be sure to fix the module on the same plane, taking care not in order to warp or twist the module.
  - b) Since the polarizer is easily damaged, pay attention not in order to scratch it.
  - c) Wipe off water drop immediately. Long contact with water may cause discoloration or spots.
  - d) When the panel surface is soiled, wipe it with absorbent cotton or other soft cloth.
  - e) Since the glass is used in the module, it may break or crack if dropped or bumped on hard surface. Handle with care.
  - f) To protect the liquid crystal from ultraviolet rays, don't leave it in direct sunlight or strong ultraviolet rays for long.

- g) Since CMOS LSI is used in this module, take care of static electricity and ground your body when handling.
- h) Observe all other precautionary requirements in handling components.

## 10. Packing form

- a) Piling-up number of cartons : MAX. 6 cartons
- b) Package quantity in one carton : MAX. 10 cartons
- c) Carton size : 380mm(W)x384mm(H)x315mm(D)
- d) Total mass of 1 carton filled with full modules : 13kg

## 11. Reliability test items

No.	Test item	Conditions
1	High temperature storage test	Ta=60℃ 240h
2	Low temperature storage test	Ta=-25℃ 240h
3	High temperature & high humidity operation test	Ta=40℃:95%RH 240h (No condensation)
4	High temperature operation test	Ta=50℃ 240h (The panel temp must be less than 60℃)
5	Low temperature operation test	Ta=0℃ 240h
6	Vibration test (non-operating)	Frequency:10~57Hz Vibration width(one side):0.075mm Frequency:58~500Hz Gravity:9.8m/s <sup>2</sup> Sweep time : 11 min. Test period : 3h (1 hour for each direction of X,Y,Z)
7	Shock test (non-operating)	Max. gravity : 490m/s <sup>2</sup> Pulse width : 11ms, sine wave Direction : ±X,±Y,±Z once for each direction.

## 【Result Evaluation Criteria】

Under the display quality test conditions with normal operation state, these shall be no change which may affect practical display function.

## 12. Others

## 1) Indication of Lot No. Label

This product indicate manufacture name "SHARP", Model No. "LQ12DX12", "Product No." and "MADE IN JAPAN" on the module.(back side)

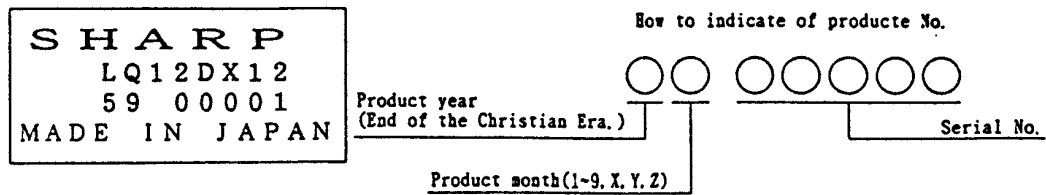

- 2) Adjusting volumes have been set optimally before shipment, so do not change any adjusted values. If adjusted values are changed, the data mentioned in this technical literature may not be satisfied.
- 3) Disassembling the module can cause permanent damage and should be strictly avoided.
- 4) Please be careful since image retention may occur when a fixed pattern is displayed for a long time.
- 5) If any problem occurs in relation to the description of this specification, it shall be resolved through discussion with spirit of cooperation.



# REIN Components GmbH

Lötscher Weg 66 · D-41334 Nettetal  
Telefon +49 (0)2153-733 112 · Telefax +49 (0)2153-733 575  
email: rein@rnc.memec.com · http://www.rein.memec.com

A MEMEC Group Company within VEBA Electronics Inc.

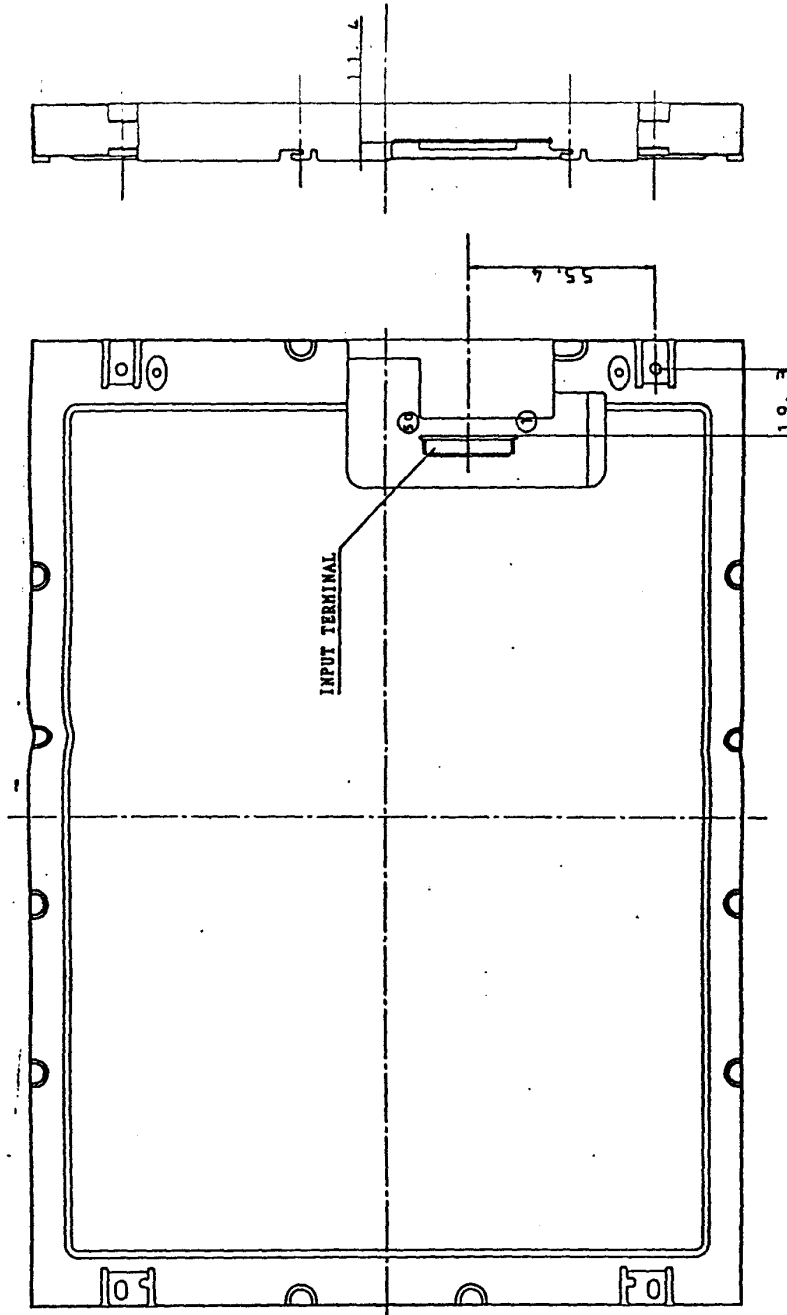

LQ12DX12 MODULE OUTLINE DIMENSIONS(BACK SIDE)

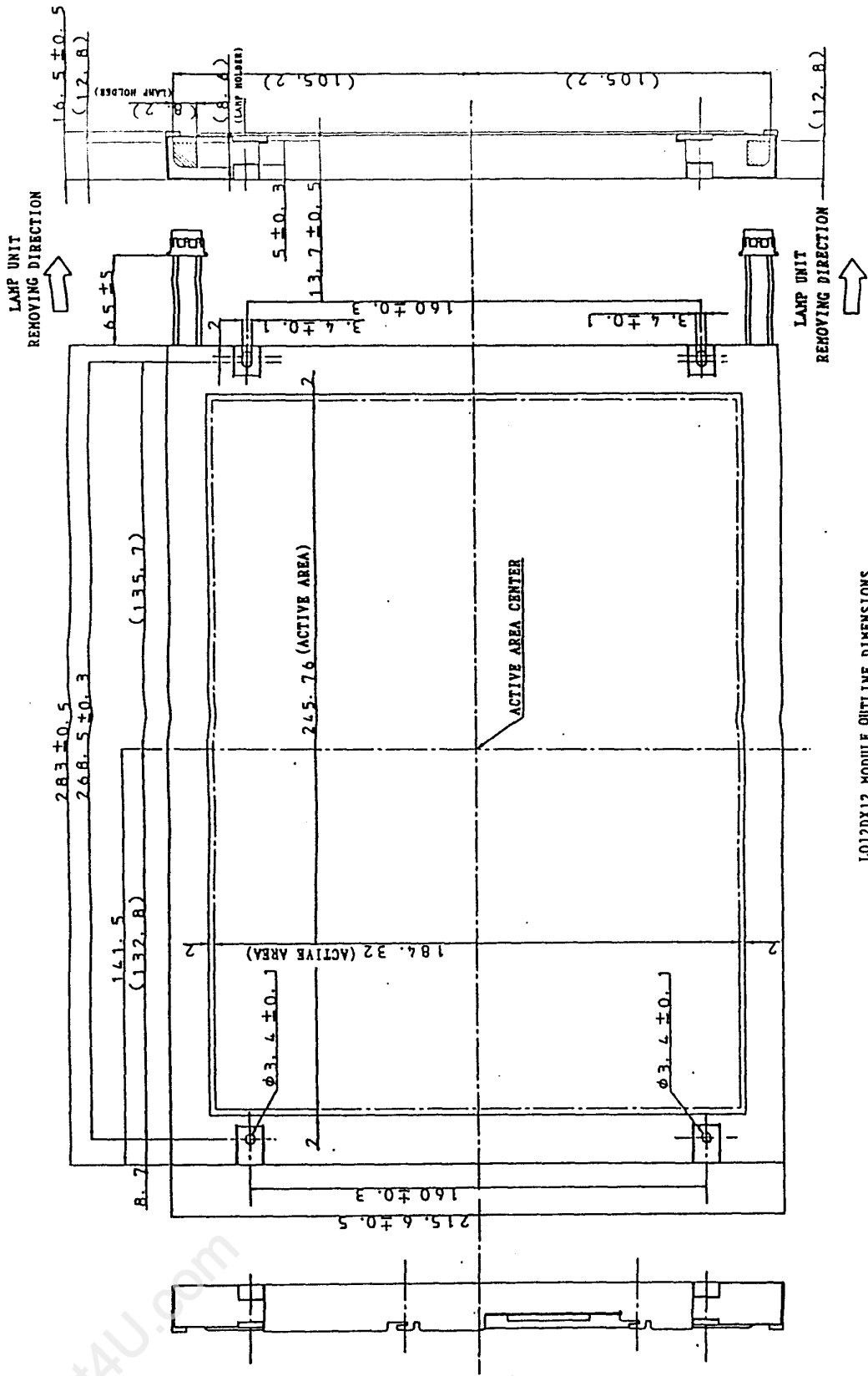

L012DX12 MODULE OUTLINE DIMENSIONS