

PREPARED BY : DATE
Y.Takeda : May.16.2013

CHECKED BY : DATE
K.Nishikubo : May.16.2013

:

SHARP

DISPLAY DEVICE BUSINESS
SHARP CORPORATION

SPECIFICATION

SPEC No. LD-25204C

FILE No.

ISSUE : May.16.2013

PAGE : 25 pages

APPLICABLE GROUP
DISPLAY DEVICE BUSINESS
DIVISION

Device Specification for

TFT-LCD module

MODEL No. **LQ133T1JW02**

CUSTOMER'S APPROVAL

DATA _____

BY _____

<PART OF TECHNICAL> (Page 1 to 25)

PRESENTED

BY  _____

H.Okuno
DEPARTMENT GENERAL MANAGER
DEVELOPMENT DEPARTMENT I
DISPLAY DEVICE UNIT II
DISPLAY DEVICE BUSINESS DIVISION

RECORDS OF REVISION

MODEL NO : LQ133T1JW02

SPEC NO: LD-25204A

DATE	REVISED	PAGE	SUMMARY	NOTE
2013.2.26	A		1 st Issue	
		3	3. Mechanical Specifications : Fix Max. value : Mass.	
		5	4-2. eDP interface Fig.4-2-2,4-2-3 : Indicate PC/LCD side.	
		7	5. Absolute Maximum Ratings :	
			Fix Max. value : Back Light supply voltage, Input voltage(eDP), Input voltage(BL).	
		8	6-1. TFT-LCD panel driving :	
			Fix Min. value : Differential Peak-to-peak Input Voltage at RX package pins,	
			Fix Typ. value : Current dissipation, Power consumption, AUX DC Common Mode Voltage,	
			Fix Max. value : Lane Intra-pair Skew at RX package pins Remove item : RX DC Common Mode Voltage	
		9	[Note 6-1-1] ON -OFF conditions for supply voltage	
			Fix Min. value : t1, t2, t3, t6, t7, t9, t10, t11, t12 Fix Max. value : t1, t2, t3, t9	
		10	[Note 6-1-2] Maximum current condition :	
			Add VDD condition.	
		11	6-2. Backlight driving :	
			Fix Min. value : Modulated light signal voltage, Brightness Control Duty Ratio, Brightness Control pulse width, Brightness Control frequency.	
			Fix Typ. value : Current dissipation, Modulated light signal Voltage, LED-BL ON/OFF High voltage.	
			Fix Max. value : Current dissipation, Modulated light signal voltage, Brightness Control frequency, LED-BL ON/OFF High voltage, LED-BL ON/OFF Low voltage.	
		18	10. Optical Characteristics :	
			Fix Typ. value : Chromaticity of red, green, blue, NTSC Fix Max. value : Response time Fix warm up time	
		21	13. Packaging Condition : Fixed values.	
		22	14. Label : Fixed label. Remove Packing bar code label	
		24	Fix Packaging conditions	
		25	Fix Outline dimensions	
2013.3.19	B	11	6 - 2. Backlight driving :	$\Delta 1$
			Change Max of Brightness Control frequency.	
2013.5.16	C	6	Delete Fig.4-2-4 HPD events	$\Delta 2$
		8	6 - 1. TFT-LCD panel driving :	
			Fix Max. value : Current dissipation, Power consumption	
		11	6 - 2. Backlight driving :	
			Add Power consumption	
		23	16. Reliability Test Items	
			Add 9. Thermal shock	
		25	Update Fig.2 Outline Dimensions	

NOTICE

This technical literature is the proprietary of SHARP and is copyrighted, with all rights reserved. Under the copyright laws, no part of this technical literature may be reproduced or transmitted in any form or by any means, electronic or mechanical for any purpose, in whole or in part, without the express written permission of SHARP. Express written permission is also required before any use of this technical literature may be made by a third party.

The application circuit examples in this technical literature are provided to explain the representative applications of SHARP's devices and are not intended to guarantee any circuit design or permit any industrial property right or other rights to be executed. SHARP takes no responsibility for any problems related to any industrial property right or a third party resulting from the use of SHARP's devices, except for those resulting directly from device manufacturing processes.

In the absence of confirmation by device specification sheets, SHARP takes no responsibility for any defects that occur in equipment using any of SHARP's devices, shown in catalogs, data books, etc. Contact SHARP in order to obtain the latest device specification sheets before using any SHARP's device.

SHARP reserves the right to make changes in the specifications, characteristics, data, materials, structures and other contents described herein at any time without notice in order to improve design or reliability. Contact SHARP in order to obtain the latest specification sheets before using any SHARP's device. Manufacturing locations are also subject to change without notice.

Observe the following points when using any device in this technical literature. SHARP takes no responsibility for damage caused by improper use of the devices.

The devices in this technical literature are designed for general electronic equipment use.

The appropriate design measures should be taken to ensure reliability and safety when SHARP's devices are used for equipment such as:

- Transportation control and safety equipment(i.e.,aircraft, trains, automobiles, etc.)
- Traffic signals • Gas leakage sensor breakers • Alarm equipment • Various safety devices etc.

SHARP's devices shall not be used for equipment that requires extremely high level of reliability, such as:

- Military and space applications • Nuclear power control equipment
- Medical equipment for life support

Contact a SHARP representative, in advance, when intending to use SHARP's devices for any "specific" applications other than those recommended by SHARP.

Contact and consult with a SHARP representative if there are any questions about the contents of this technical literature.

Table of contents

1. Application	3
2. Overview	3
3. Mechanical Specifications	3
4. Input Terminals	4
4 - 1. Symbol	4
4 - 2. eDP interface	5
5. Absolute Maximum Ratings	7
6. Electrical Characteristics	8
6 - 1. TFT-LCD panel driving	8
6 - 2. Backlight driving	11
7. Timing Characteristics of Input Signals	12
7 - 1. Timing characteristics	12
7 - 2. Input data signals and display position on the screen	13
8. Input Signals, Basic Display Colors and Gray Scale of Each Color	14
9. EDID Specifications	15
9 - 1. EDID data structure	15
10. Optical Characteristics	18
11. Display Quality	19
12. Handling Precautions	20
13. Packaging Condition	21
14. Label	22
15. RoHS Directive	22
16. Reliability Test Items	23
Fig. 1 Packing Form	24
Fig. 2 Outline Dimensions	25

1. Application

This specification applies to a color TFT-LCD module, LQ133T1JW02.

2. Overview

This module is a color active matrix LCD module incorporating Oxide TFT (Thin Film Transistor). It is composed of a color TFT-LCD panel, driver ICs, a control circuit and power supply circuit, and a backlight unit. Graphics and texts can be displayed on a 2560×3×1440 dots panel with (16,777,216) colors by using eDP (Embedded Display Port) Ver1.3 to interface and supplying +3.3V DC supply voltage for TFT-LCD panel driving and applying DC supply voltage for LED backlight-driving DC/DC converter.

In this TFT-LCD panel, color filters for excellent color performance and backlights for high brightness are incorporated to realize brighter and clearer pictures, making this model optimum for use in multi-media applications.

Optimum viewings are in all directions.

Backlight-driving LED controller is built in this module.

3. Mechanical Specifications

Parameter	Specifications	Unit
Display size	33.78 (13.3") Diagonal	cm
Active area	293.76 (H)×165.24 (V)	mm
Pixel format	2560 (H)×1440 (V)	pixel
	(1 pixel = R+G+B dots)	
Pixel pitch	0.11475 (H)×0.11475 (V)	mm
Pixel configuration	R,G,B vertical stripe	
Display mode	Normally black	
Surface treatment	Anti-glare coating (Haze value 42%)	

Outline dimensions

Parameter		Min.	Typ.	Max.	Unit	Remark
Unit outline dimensions [Note 3-1]	Width	304.48	304.98	305.48	mm	
	Height	177.7	178.2	178.7	mm	W/o PCB
		187.7	188.2	188.7	mm	W/ PCB and tape
	Depth	2.152	2.352	2.552	mm	W/o shielding tape
		2.202	2.402	2.602	mm	W/ shielding tape
Mass		205	225	g		

[Note 3-1] Outline dimensions is shown in Fig.2

4. Input Terminals

4 - 1. Symbol

CN1 (eDP signals, +3.3V DC power supply, and B/L power supply)

Pin No.	Symbol	I/O	Function	Remark
1	NC	-	Reserved for LCD manufacturer's use	[Note4-1-1]
2	H_GND	P	High Speed Ground	
3	Lane3_N	I	Complement Signal Link Lane 3	
4	Lane3_P	I	True Signal Link Lane 3	
5	H_GND	P	High Speed Ground	
6	Lane2_N	I	Complement Signal Link Lane 2	
7	Lane2_P	I	True Signal Link Lane 2	
8	H_GND	P	High Speed Ground	
9	Lane1_N	I	Complement Signal Link Lane 1	
10	Lane1_P	I	True Signal Link Lane 1	
11	H_GND	P	High Speed Ground	
12	Lane0_N	I	Complement Signal Link Lane 0	
13	Lane0_P	I	True Signal Link Lane 0	
14	H_GND	P	High Speed Ground	
15	AUX_CH_P	I	True Signal Auxiliary Channel	
16	AUX_CH_N	I	Complement Signal Auxiliary Channel	
17	H_GND	P	High Speed Ground	
18	VDD	P	LCD logic and driver power(3.3V)	
19	VDD	P	LCD logic and driver power(3.3V)	
20	VDD	P	LCD logic and driver power(3.3V)	
21	VDD	P	LCD logic and driver power(3.3V)	
22	NC	-	Reserved for LCD manufacturer's use	[Note4-1-1]
23	LCD_GND	P	LCD logic and driver ground	
24	LCD_GND	P	LCD logic and driver ground	
25	LCD_GND	P	LCD logic and driver ground	
26	LCD_GND	P	LCD logic and driver ground	
27	HPD	O	HPD signal pin	
28	BL_GND	P	Backlight ground	
29	BL_GND	P	Backlight ground	
30	BL_GND	P	Backlight ground	
31	BL_GND	P	Backlight ground	
32	BL_ENABLE	I	Backlight On/Off	
33	BL_PWM_DIM	I	System PWM	
34	NC	-	Reserved for LCD manufacturer's use	[Note4-1-1]
35	NC	-	Reserved for LCD manufacturer's use	[Note4-1-1]
36	VBL	P	Backlight power	
37	VBL	P	Backlight power	
38	VBL	P	Backlight power	
39	VBL	P	Backlight power	
40	NC	-	Reserved for LCD manufacturer's	[Note4-1-1]

※ I : Input , O : Output , P : Power:

[Note 4-1-1] Don't input any signals or any powers into a NC pin. Keep the NC pin open.

[Note 4-1-2] The shielding case is connected with signal GND.

- Connector used : HD1S040HA1 (JAE)
- Corresponding connector : HD1P040MA1 (JAE) or 20454-040T (I-PEX)

(Sharp is not responsible to its product quality, if the user applies a connector not corresponding to the above model.)

4 - 2. eDP interface

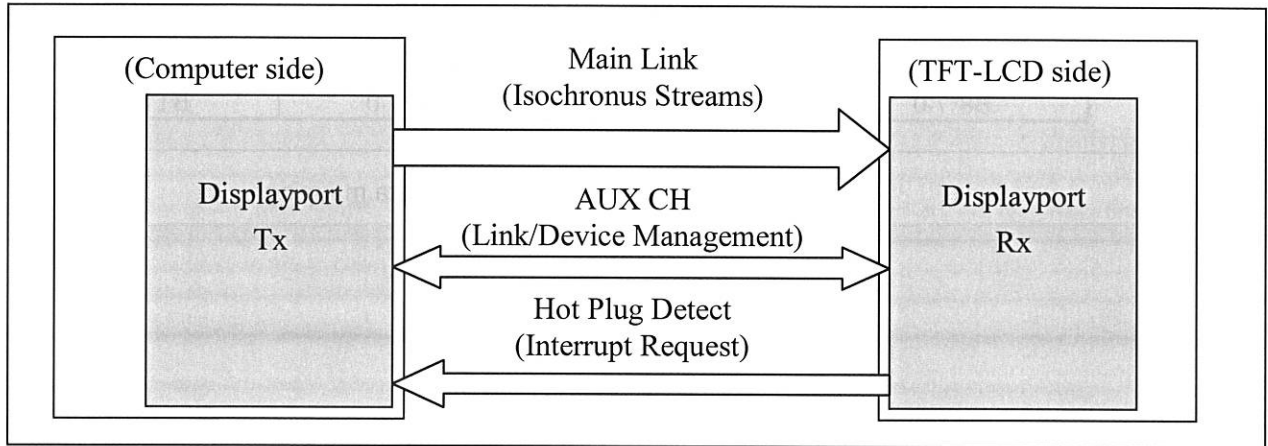

Fig.4-2-1 DP architecture.

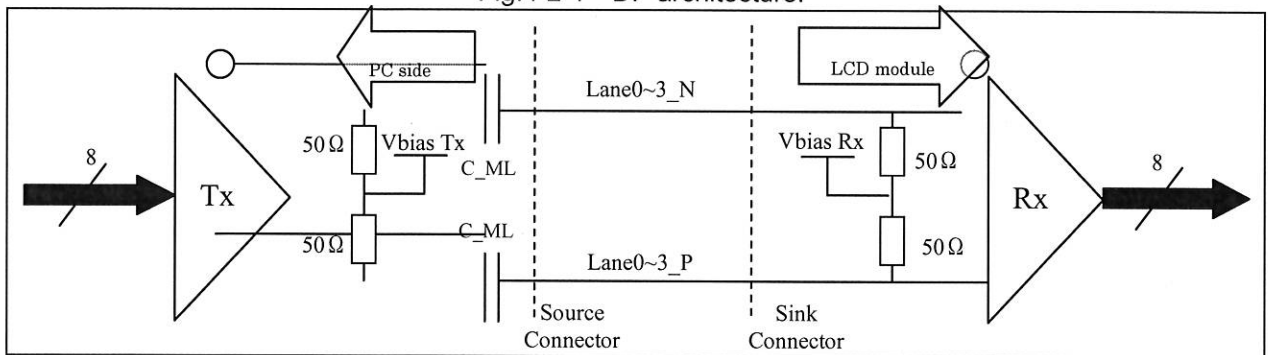

Fig.4-2-2 Main Link differential pair.

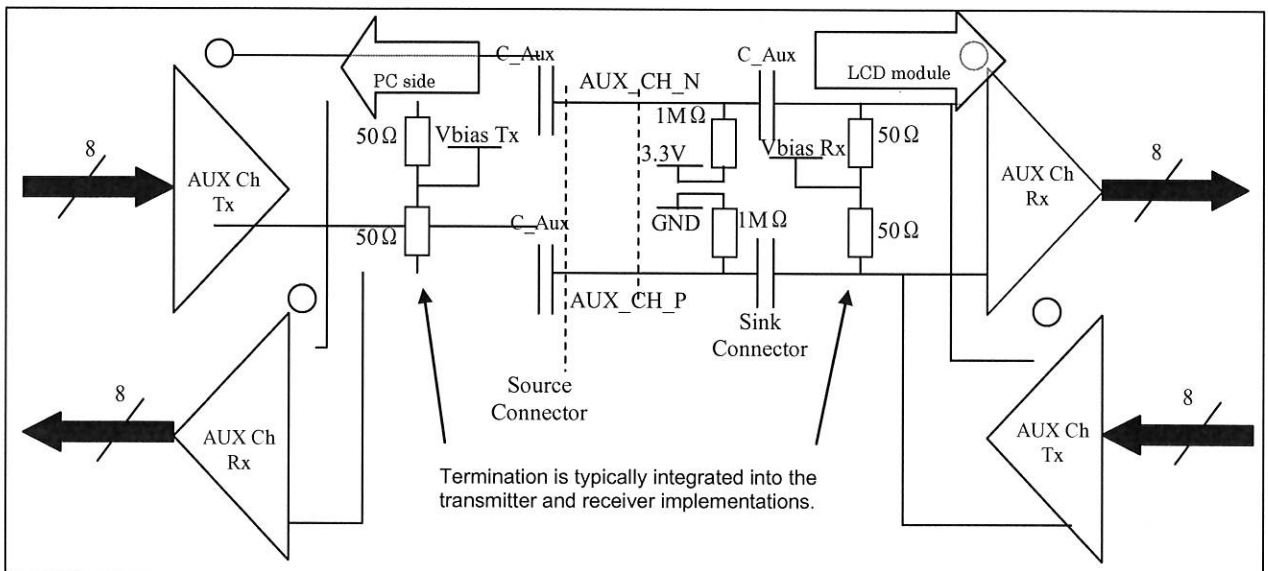

Fig.4-2-3 AUX Link differential pair.

Lane0	Lane1	Lane2	Lane3
R0-7:0	R1-7:0	R2-7:0	R3-7:0
G0-7:0	G1-7:0	G2-7:0	G3-7:0
B0-7:0	B1-7:0	B2-7:0	B3-7:0
R4-7:0	R5-7:0	R6-7:0	R7-7:0
G4-7:0	G5-7:0	G6-7:0	G7-7:0
B4-7:0	B5-7:0	B6-7:0	B7-7:0
R8-7:0	R9-7:0	R10-7:0	R11-7:0
G8-7:0	G9-7:0	G10-7:0	G11-7:0
B8-7:0	B9-7:0	B10-7:0	B11-7:0

Fig.4-2-5 eDP 4 lane 8 bit input data mapping.

5. Absolute Maximum Ratings

Parameter	Symbol	Condition	Ratings		Unit	Remark
			Min.	Max.		
+3.3V supply voltage	VDD	Ta=25°C	-0.3	+4.0	V	
Back Light supply voltage	VBL	Ta=25°C	-0.3	+26.5	V	
Input voltage(eDP)	VI	Ta=25°C	-0.3	1.8	V	[Note 5-1]
Input voltage(BL)	VBL_I	Ta=25°C	-0.3	VDD+0.3	V	[Note 5-2]
Storage temperature (ambient)	Tstg	—	-20	+60	°C	[Note 5-3]
Operating temperature(ambient)	Topa	—	0	+50	°C	

[Note 5-1] eDP signals

[Note 5-2] Back light control signals (BL_ENABLE, BL_PWM_DIM)

[Note 5-3] Humidity : 90%RH Max. at Ta ≤ +40°C.

Maximum wet-bulb temperature at +39°C or less at Ta > +40°C.

No condensation.

6. Electrical Characteristics

6 - 1. TFT-LCD panel driving

Ta = +25°C

DC Electrical Characteristics						
Parameter	Symbol	Min.	Typ.	Max.	Unit	Remark
Supply voltage	VDD	+3.0	+3.3	+3.6	V	[Note 6-1-1]
Current dissipation	IDD	—	424	760	mA	[Note 6-1-2] $\Delta 2$
Power consumption	P _{VDD}	—	1.4	2.74	W	$\Delta 2$
Permissive input ripple voltage	V _{RP}	—	—	100	mV _{P-P}	VDD = +3.3V
eDP AUX Channel Characteristics						
Parameter	Symbol	Min.	Typ.	Max.	Unit	Remark
Unit Interval for AUX channel	UI _{AUX}	0.4	0.5	0.6	μs	
peak-to-peak voltage at TP1	V _{AUX-DIFF-p}	0.32	-	1.36	V	
AUX DC Common Mode Voltage	V _{AUX-DC-CM}	-	0.9	-	V	
AUX Short Circuit Current Limit	I _{AUX_SHORT}	-	-	90	mA	
AUX CH termination DC resistance	R _{AUX-TERM}	-	100	-	Ω	
AUX AC Coupling Capacitor	C _{AUX}	75	-	200	nF	
Number of pre-charge pulses	Pre-charge pulses	10	-	16	-	
eDP Main Link Receiver Characteristics						
Parameter	Symbol	Min.	Typ.	Max.	Unit	Remark
Link clock down spreading	Down_Spread_Amplitude	0	-	0.5	%	
Differential Peak-to-peak Input Voltage at RX package pins	V _{RX-DIFF-p-p}	90	-	1200	mV	
Differential Return Loss at 1.35 GHz at RX package pins	RL _{RX-DIFF}	9	-	-	dB	
Differential termination resistance	V _{RX-TERM}	-	100	-	Ω	
RX Short Circuit Current Limit	I _{RX-SHORT}	-	-	50	mA	
Lane Intra-pair Skew at RX package pins	L _{RX-SKEW-INTRAPAIR-High-Bit-Rate}	-	-	60	ps	

[Note 6-1-1] ON-OFF conditions for supply voltage

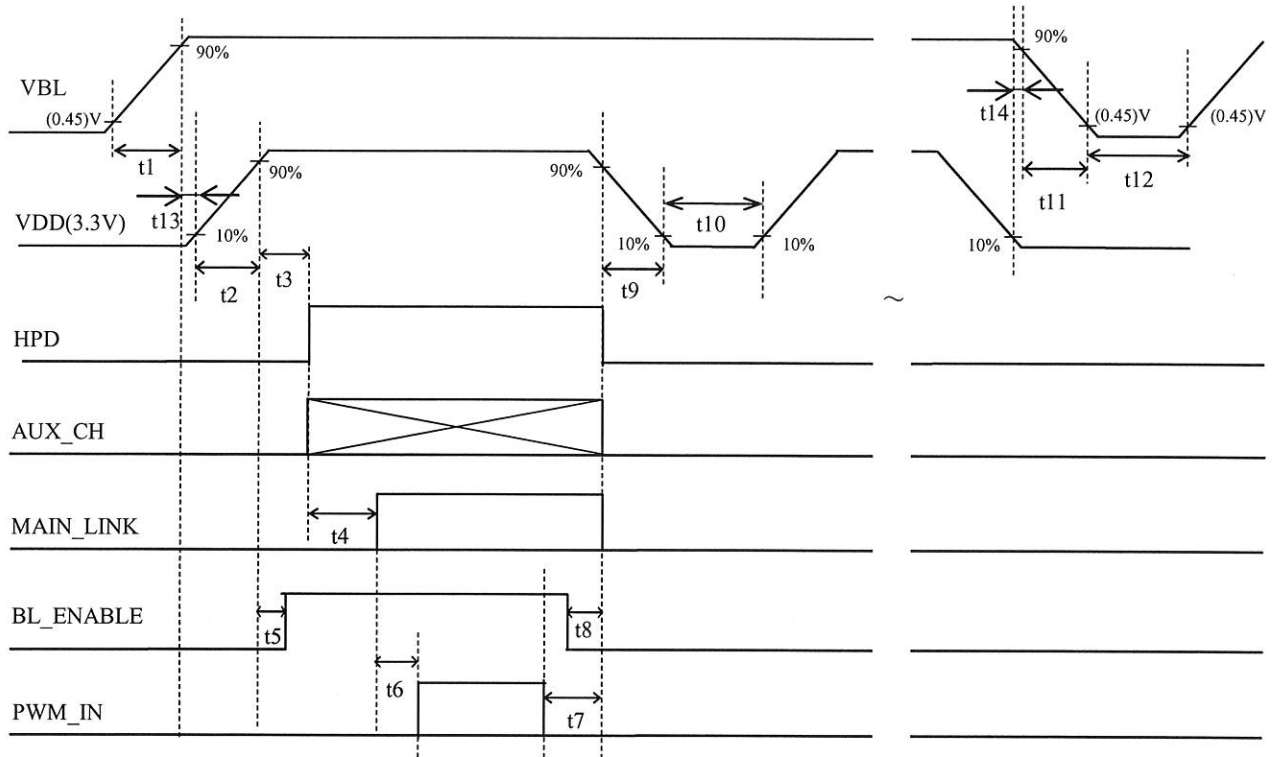

[Note] Do not keep the interface signal high-impedance or unusual signal when power is on.

Symbol	Min	Max	Unit	Note
t1	0.5	10	ms	
t2	0.5	10	ms	
t3	—	100	ms	
t4	0	—	ms	
t5	0	—	ms	
t6	17	—	ms	
t7	17	—	ms	
t8	0	—	ms	
t9	1	50	ms	[Note 1]
t10	500	—	ms	
t11	0.1	—	ms	
t12	1	—	s	
t13	0	—	ms	
t14	0	—	ms	

[Note 1] As for the power off sequence for VDD (t9), Be sure to keep above mentioned timing.

If the VDD power off sequence timing is other than shown above, LCD may cause permanent damage.

*1 : As for the power sequence for backlight, it is recommended to apply above mentioned input timing.

If the backlight is light on and off at a timing other than shown above, displaying image may get

disturbed.

VDD-dip conditions

- 1) $2.5\text{ V} \leq \text{VDD} < 3.0\text{ V}$
 $t_d \leq 10\text{ ms}$

Under above condition, the display image should return to an appropriate figure after VDD voltage recovers.

- 2) $\text{VDD} < 2.5\text{ V}$

VDD-dip conditions should also follow the ON-OFF conditions for supply voltage

[Note 6-1-2] Typical current condition: 16-gray-bar pattern.

VDD=+3.3V

Maximum current condition: Dot checker pattern

VDD=+3.3V

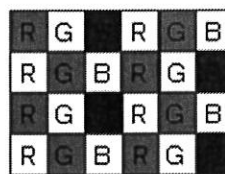
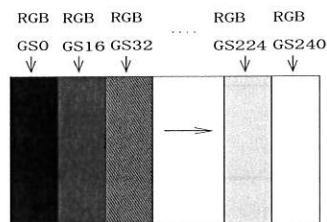
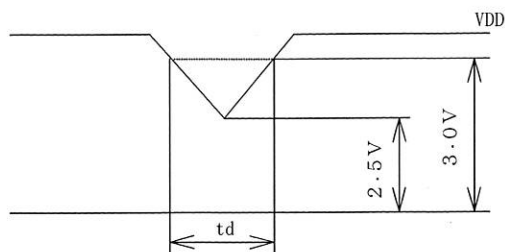

6 - 2. Backlight driving

The backlight system is an edge-lighting type with white-LED.

(It is usually required to measure under the following condition. : $T_a=25^{\circ}\text{C} \pm 2^{\circ}\text{C}$)

Parameter	Symbol	Min.	Typ.	Max	Unit	Remark
Supply voltage	V_{BL}	5.5	12.0	21.0	V	
Current dissipation	I_{BL}	—	245	680	mA	$V_{LED} = 12.0\text{V(TYP)}$ $V_{LED} = 5.5\text{V(MAX)}$ Duty Ratio=100%
Power consumption	P_{BL}	—	2.94	3.74	W	$\Delta 2$
Modulated light signal voltage	V_{PWMH}	2.0	—	VDD	V	
	V_{PWL}	0	—	0.8	V	
Brightness Control Duty Ratio	Duty	1	—	100	%	【Note6-2-1】
Brightness Control pulse width	T_{PWM}	10	—	—	us	【Note6-2-2】
Brightness Control frequency	f_{PWM}	200	200	2,000	Hz	$\Delta 1$
LED-BL ON/OFF High voltage	V_{CNTH}	2.0	—	VDD	V	【Note6-2-3】
LED-BL ON/OFF Low voltage	V_{CNTL}	0	—	0.8	V	
Input signal pin current	I_{IN}	—	—	1.0	μA	V_{CNT}, V_{PWM} pin
LED lifetime	-	—	10,000	—	h	LED

【Note6-2-1】 V_{vr} Input : 100%= Max luminance 5%= Min luminance

【Note6-2-2】 The minimum value of the dimming signal pulse width is assumed regulations of the width of high and the width of low.

【Note6-2-3】 V_{CNT} Input : High or OPEN = BL turn on, Low =BL turn off

V_{BL} -dip conditions

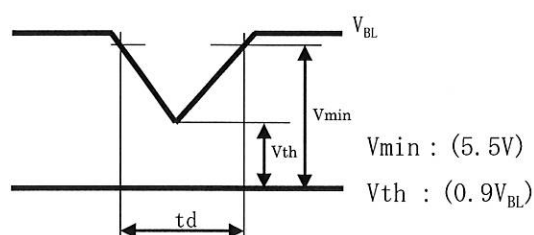

$$1) V_{th} \leq V_{BL} < V_{min} : t_d \leq 20\text{ms}$$

2) $V_{BL} < V_{th}$: The condition of instantaneous voltage drop is apply to input voltage sequences

7. Timing Characteristics of Input Signals

7 - 1. Timing characteristics

VDD=+3.0V~+3.6V, Ta=0°C~+50°C

Parameter	Symbol	Min.	Typ.	Max.	Unit	Remark
Clock	Frequency	—	241.5	—	MHz	[Note 7-1-1]
Data enable Signal	Horizontal period	TH	—	2720	—	clock
			—	11.263	—	μs
	Horizontal period (High)	THd	—	2560	—	clock
	Vertical period	TV	—	1481	—	Line
			—	16.68	—	ms
Vertical period (High)	TVd	—	1440	—	line	

[Note 7-1-1] In case of using the long vertical period, the deterioration of display quality, flicker, etc., may occur.

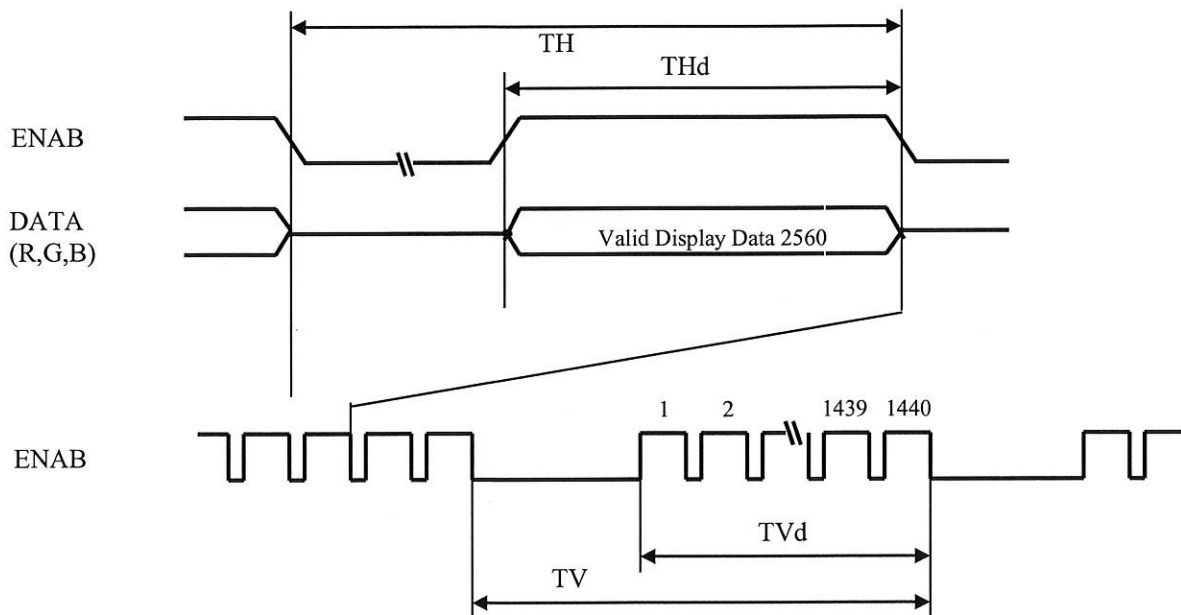

7 - 2. Input data signals and display position on the screen

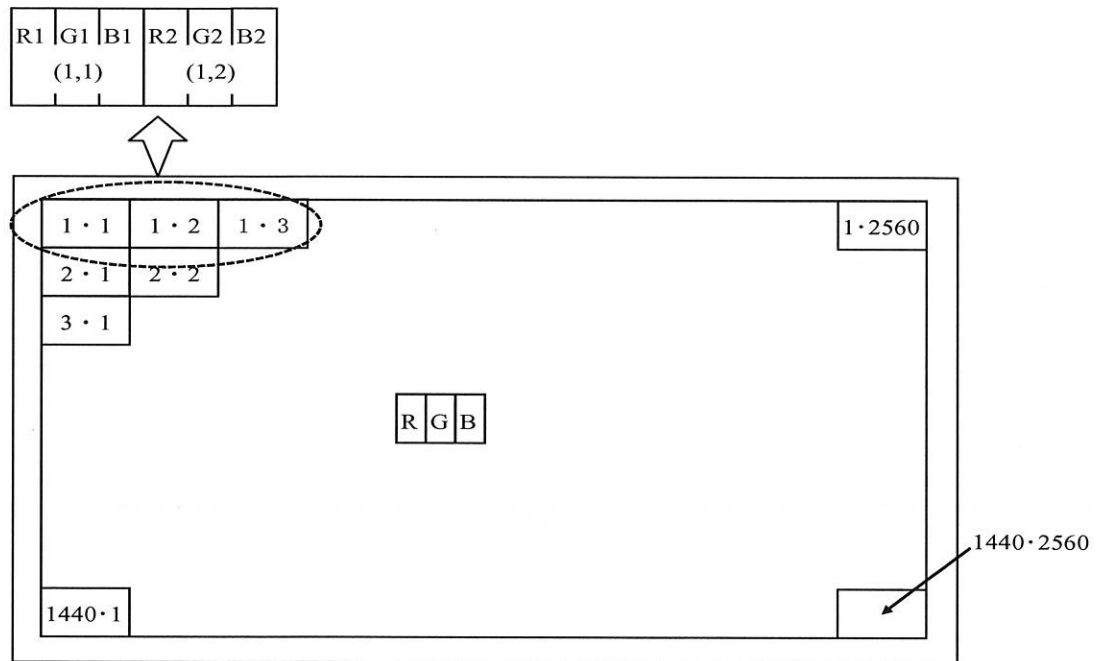

Display position of input data(V · H)

8. Input Signals, Basic Display Colors and Gray Scale of Each Color

Colors & Gray Scale	Gray Scale	Data signal																													
		R0	R1	R2	R3	R4	R5	R6	R7	G0	G1	G2	G3	G4	G5	G6	G7	B0	B1	B2	B3	B4	B5	B6	B7						
		LSB								MSB								LSB								MSB					
Basic Color	Black	—	0	0	0	0	0	0	0	0	0	0	0	0	0	0	0	0	0	0	0	0	0	0	0						
	Blue	—	0	0	0	0	0	0	0	0	0	0	0	0	0	0	0	0	1	1	1	1	1	1	1						
	Green	—	0	0	0	0	0	0	0	0	1	1	1	1	1	1	1	1	0	0	0	0	0	0	0						
	Cyan	—	0	0	0	0	0	0	0	0	1	1	1	1	1	1	1	1	1	1	1	1	1	1	1						
	Red	—	1	1	1	1	1	1	1	1	0	0	0	0	0	0	0	0	0	0	0	0	0	0	0						
	Magenta	—	1	1	1	1	1	1	1	1	0	0	0	0	0	0	0	0	1	1	1	1	1	1	1						
	Yellow	—	1	1	1	1	1	1	1	1	1	1	1	1	1	1	1	1	0	0	0	0	0	0	0						
	White	—	1	1	1	1	1	1	1	1	1	1	1	1	1	1	1	1	1	1	1	1	1	1	1						
Gray Scale of Red	Black	GS0	0	0	0	0	0	0	0	0	0	0	0	0	0	0	0	0	0	0	0	0	0	0							
	↑	GS1	1	0	0	0	0	0	0	0	0	0	0	0	0	0	0	0	0	0	0	0	0	0							
	Darker	GS2	0	1	0	0	0	0	0	0	0	0	0	0	0	0	0	0	0	0	0	0	0	0							
	↑	↓	↓								↓								↓												
	↓	↓	↓								↓								↓												
	Brighter	GS253	1	0	1	1	1	1	1	1	0	0	0	0	0	0	0	0	0	0	0	0	0	0	0						
	↓	GS254	0	1	1	1	1	1	1	1	0	0	0	0	0	0	0	0	0	0	0	0	0	0	0						
	Red	GS255	1	1	1	1	1	1	1	1	0	0	0	0	0	0	0	0	0	0	0	0	0	0	0						
Gray Scale of Green	Black	GS0	0	0	0	0	0	0	0	0	0	0	0	0	0	0	0	0	0	0	0	0	0	0							
	↑	GS1	0	0	0	0	0	0	0	0	1	0	0	0	0	0	0	0	0	0	0	0	0	0							
	Darker	GS2	0	0	0	0	0	0	0	0	0	1	0	0	0	0	0	0	0	0	0	0	0	0							
	↑	↓	↓								↓								↓												
	↓	↓	↓								↓								↓												
	Brighter	GS253	0	0	0	0	0	0	0	0	1	0	1	1	1	1	1	1	0	0	0	0	0	0	0						
	↓	GS254	0	0	0	0	0	0	0	0	0	1	1	1	1	1	1	1	0	0	0	0	0	0	0						
	Green	GS255	0	0	0	0	0	0	0	0	1	1	1	1	1	1	1	1	0	0	0	0	0	0	0						
Gray Scale of Blue	Black	GS0	0	0	0	0	0	0	0	0	0	0	0	0	0	0	0	0	0	0	0	0	0	0							
	↑	GS1	0	0	0	0	0	0	0	0	0	0	0	0	0	0	0	0	1	0	0	0	0	0							
	Darker	GS2	0	0	0	0	0	0	0	0	0	0	0	0	0	0	0	0	0	1	0	0	0	0							
	↑	↓	↓								↓								↓												
	↓	↓	↓								↓								↓												
	Brighter	GS253	0	0	0	0	0	0	0	0	0	0	0	0	0	0	0	0	1	0	1	1	1	1	1						
	↓	GS254	0	0	0	0	0	0	0	0	0	0	0	0	0	0	0	0	0	1	1	1	1	1	1						
	Blue	GS255	0	0	0	0	0	0	0	0	0	0	0	0	0	0	0	0	1	1	1	1	1	1	1						

0 : Low level voltage, 1 : High level voltage

Each basic color can be displayed in 256 gray scales from 8 bit data signals.

According to the combination of 24 bit data signals, the 16.7M color display can be achieved on the screen.

9. EDID Specifications

9 - 1. EDID data structure

This is the EDID(Extended Display Identification Data) data formats to support displays as defined in the VESA Plug & Display

Byte (decimal)	Byte (hex)	Field Name and Comments	Value (hex)	Value (binary)
0	00	Header	00	00000000
1	01	Header	FF	11111111
2	02	Header	FF	11111111
3	03	Header	FF	11111111
4	04	Header	FF	11111111
5	05	Header	FF	11111111
6	06	Header	FF	11111111
7	07	Header	00	00000000
8	08	EISA manufacture code = SHP	4D	01001101
9	09	EISA manufacture code (Compressed ASCII)	10	00010000
10	0A	Product code (LQ133T1JW02 : 5119)	FF	11111111
11	0B	Product code (hex,LSB first)	13	00010011
12	0C	LCD module Serial No (fixed "0")	00	00000000
13	0D	LCD module Serial No (fixed "0")	00	00000000
14	0E	LCD module Serial No (fixed "0")	00	00000000
15	0F	LCD module Serial No (fixed "0")	00	00000000
16	10	Week of manufacture	00	00000000
17	11	Year of manufacture - 1990 (ex 2000 - 1990 = 10)	17	00010111
18	12	EDID structure version # = 1	01	00000001
19	13	EDID revision # = 4	04	00000100
20	14	Video i/p definition = Digital 8bit DP support	A5	10100101
21	15	Max H image size(cm) = 29cm	1D	00011101
22	16	Max V image size(cm) = 17cm	11	00010001
23	17	Display gamma (2.2×100) - 100 = 120	78	01111000
24	18	Feature support(stanby,suspend,RGB color/Prefer Time)	06	00000110
25	19	Red/Green Low bit(RxRy/GxGy)	DE	11011110
26	1A	Blue/White Low bit(BxBy/WxWy)	50	01010000
27	1B	Red X(Rx) (written value 0.64)	A3	10100011
28	1C	Red Y(Ry) (written value 0.33)	54	01010100
29	1D	Green X(Gx) (written value 0.3)	4C	01001100
30	1E	Green Y(Gy) (written value 0.6)	99	10011001
31	1F	Blue X(Bx) (written value 0.15)	26	00100110
32	20	Blue Y(By) (written value 0.06)	0F	00001111
33	21	White X(Wx) (written value 0.313)	50	01010000
34	22	White Y(Wy) (written value 0.329)	54	01010100
35	23	Established timings 1	00	00000000
36	24	Established timings 2	00	00000000
37	25	Established timings 3(Manufacture's reserved timing)	00	00000000
38	26	Standard timing ID1	01	00000001
39	27	Standard timing ID1	01	00000001
40	28	Standard timing ID2	01	00000001
41	29	Standard timing ID2	01	00000001
42	2A	Standard timing ID3	01	00000001
43	2B	Standard timing ID3	01	00000001

44	2C	Standard timing ID4	01	00000001
45	2D	Standard timing ID4	01	00000001
46	2E	Standard timing ID5	01	00000001
47	2F	Standard timing ID5	01	00000001
48	30	Standard timing ID6	01	00000001
49	31	Standard timing ID6	01	00000001
50	32	Standard timing ID7	01	00000001
51	33	Standard timing ID7	01	00000001
52	34	Standard timing ID8	01	00000001
53	35	Standard timing ID8	01	00000001
54	36	Detailed timing descriptor#1 fck/10000 (=241.5MHz/10000=24150=5E56h)	56	01010110
55	37	#1 fck	5E	01011110
56	38	#1 Horizontal active 2560=A00h 00h	00	00000000
57	39	#1 Horizontal blanking 160=0A0h A0h	A0	10100000
58	3A	#1 Horizontal active/Horizontal blanking A0h	A0	10100000
59	3B	#1 Vertical active 1440=5A0h A0h	A0	10100000
60	3C	#1 Vertical blanking 41=029h 29h	29	00101001
61	3D	#1 Vertical active/Vertical blanking 50h	50	01010000
62	3E	#1 Horizontal sync , offset(Thfp) 48=030h 30h	30	00110000
63	3F	#1 Horizontal sync , width 32=020h 20h	20	00100000
64	40	#1 Vertical sync,offset / Vertical sync,width (offset=3h/width=5h)	35	00110101
65	41	#1 Horizontal sync offset/width/Vertical sync offset/width	00	00000000
66	42	#1 Horizontal image size 293.76mm=126h 26h	26	00100110
67	43	#1 Vertical image size 165mm=0A5h A5h	A5	10100101
68	44	#1 Horizontal image size / Vertical image size 10h	10	00010000
69	45	Horizontal boader	00	00000000
70	46	Vertical boader	00	00000000
71	47	Flags(Non-interlaced=0/non 3D=00/Degital separate=11/Horizontal polarity/Vertical polarity=00)	18	00011000
72	48	Detailed timing descriptor#2 fck/10000	00	00000000
73	49	#2 fck	00	00000000
74	4A	#2 Horizontal active	00	00000000
75	4B	#2 Horizontal blanking	10	00010000
76	4C	#2 Horizontal active/Horizontal blanking	00	00000000
77	4D	#2 Vertical active	00	00000000
78	4E	#2 Vertical blanking	00	00000000
79	4F	#2 Vertical active/Vertical blanking	00	00000000
80	50	#2 Horizontal sync , offset	00	00000000
81	51	#2 Horizontal sync , width	00	00000000
82	52	#2 Vertical sync,offset / Vertical sync,width	00	00000000
83	53	#2 Horizontal sync offset/width/Vertical sync offset/width	00	00000000
84	54	#2 Horizontal image size	00	00000000
85	55	#2 Vertical image size	00	00000000
86	56	#2 Horizontal image size / Vertical image size	00	00000000
87	57	Horizontal boader	00	00000000
88	58	Vertical boader	00	00000000
89	59	Flags	00	00000000
90	5A	Detailed timing descriptor #3	00	00000000
91	5B	Flag	00	00000000
92	5C	Reserved	00	00000000
93	5D	Dummy Descriptor	10	00010000
94	5E	Flag	00	00000000

95	5F	1st Dummy	00	00000000
96	60	2nd Dummy	00	00000000
97	61	3rd Dummy	00	00000000
98	62	4th Dummy	00	00000000
99	63	5th Dummy	00	00000000
100	64	6th Dummy	00	00000000
101	65	7th Dummy	00	00000000
102	66	8th Dummy	00	00000000
103	67	9th Dummy	00	00000000
104	68	10th Dummy	00	00000000
105	69	11th Dummy	00	00000000
106	6A	New line character #3 indicates end	00	00000000
107	6B	Padding with "blank" character	00	00000000
108	6C	Detailed timing descriptor #4	00	00000000
109	6D	Flag	00	00000000
110	6E	Reserved	00	00000000
111	6F	Display Product name	FC	11111100
112	70	Flag	00	00000000
113	71	Supplier P/N#1 (L)	4C	01001100
114	72	Supplier P/N#2 (Q)	51	01010001
115	73	Supplier P/N#3 (1)	31	00110001
116	74	Supplier P/N#4 (3)	33	00110011
117	75	Supplier P/N#5 (3)	33	00110011
118	76	Supplier P/N#6 (T)	54	01010100
119	77	Supplier P/N#7 (1)	31	00110001
120	78	Supplier P/N#8 (J)	4A	01001010
121	79	Supplier P/N#9 (W)	57	01010111
122	7A	Supplier P/N#10 (0)	30	00110000
123	7B	Supplier P/N#11 (2)	32	00110010
124	7C	Supplier P/N#12 ("Space")	0A	00001010
125	7D	(If<13 char,then terminate with ASCII code 0Ah,set remaining char 20h)	20	00100000
126	7E	Extension flag	00	00000000
127	7F	Checksum	B0	10110000

10. Optical Characteristics

Ta=+25°C, VDD=+3.3V

Parameter		Symbol	Condition	Min.	Typ.	Max.	Unit	Remark		
Viewing angle range	Horizontal	$\theta 21, \theta 22$	CR>10	70	80	89	deg.	[Note 9-1, 9-3, 9-4, 9-6]		
	Vertical	$\theta 11$		70	80	89	deg.			
		$\theta 12$		70	80	89	deg.			
Contrast ratio		CR	$\theta = 0^\circ$	700	1000	—		[Note 9-2, 9-4, 9-6]		
Response time		$\tau r + \tau d$		—	25	50	ms	[Note 9-2, 9-5, 9-6]		
Chromaticity of white		x	$\theta = 0^\circ$	0.283	0.313	0.343		[Note 9-2, 9-6] Normal operation (PWM Duty=100%)		
		y		0.299	0.329	0.359				
Chromaticity of red		x		—	0.640	—				
		y		—	0.330	—				
Chromaticity of green		x		—	0.300	—				
		y		—	0.600	—				
Chromaticity of blue		x		—	0.150	—				
		Y		—	0.060	—				
NTSC ratio						72			%	
Luminance of white		Y_{LI}			280	350	—		cd/m ²	
White Uniformity		δ_w	$\theta = 0^\circ$	—	1.25	1.40		[Note 9-2, 9-7]		

※ The measurement shall be taken 30 minutes after lighting the module at the following rating:

Condition: PWM Duty = 100%

The optical characteristics shall be measured in a dark room or equivalent.

[Note 9-1] Measurement of viewing angle range and Response time.

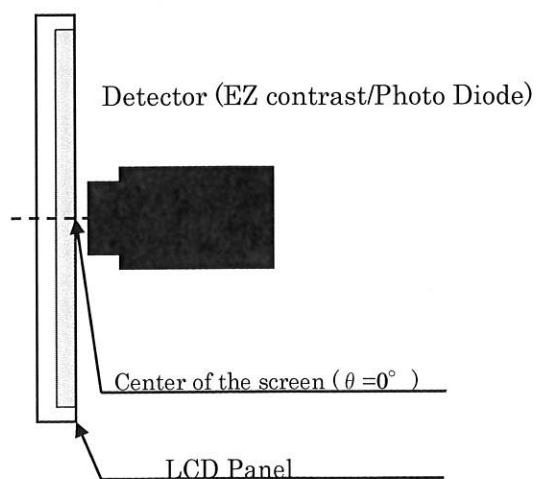

Viewing angle range: EZ-CONTRAST
/Response time: Photo diode)

[Note 9-2] Measurement of luminance and Chromaticity and Contrast.

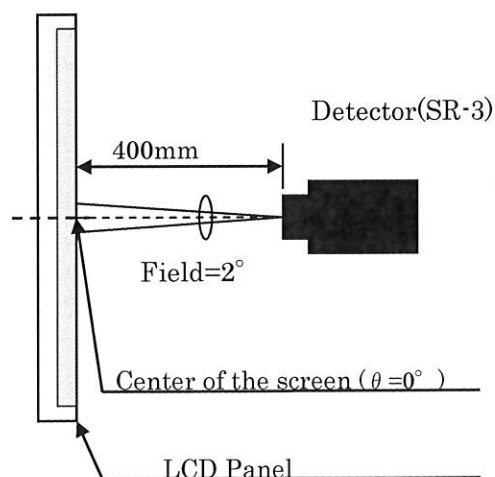

LCD Panel

[Note 9-3] Definitions of viewing angle range:

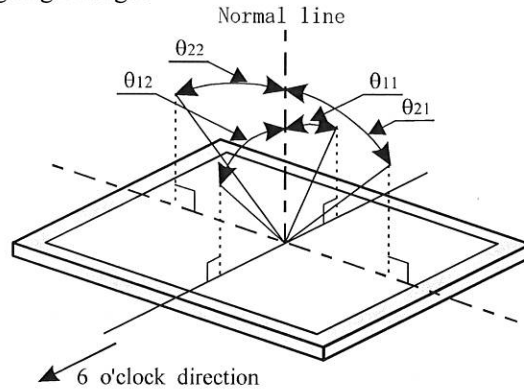

[Note 9-4] Definition of contrast ratio:

The contrast ratio is defined as the following.

$$\text{Contrast Ratio (CR)} = \frac{\text{Luminance (brightness) with all pixels white}}{\text{Luminance (brightness) with all pixels black}}$$

[Note 9-5] Definition of response time:

The response time is defined as the following figure and shall be measured by switching the input signal for "black" and "white" .

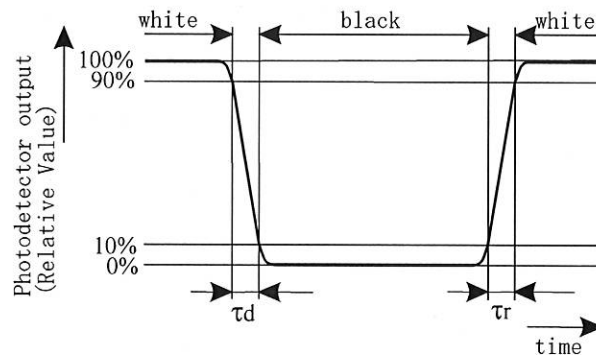

[Note 9-6] This shall be measured at center of the screen.

[Note 9-7] Definition of white uniformity:

White uniformity is defined as the following with five measurements (A~E).

$$\delta w = \frac{\text{Maximum Luminance of five points (brightness)}}{\text{Minimum Luminance of five points (brightness)}}$$

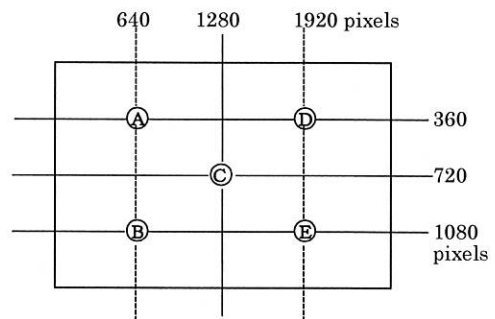

11. Display Quality

The display quality of the color TFT-LCD module shall be in compliance with the Incoming Inspection Standard.

12. Handling Precautions

- a) Be sure to turn off the power supply when inserting or disconnecting the cable.
Please insert for too much stress not to join a connector in the case of insertion of a connector.
- b) Be sure to design the cabinet so that the module can be installed without any extra stress such as warp or twist.
- c) Since the front polarizer is easily damaged, pay attention not to scratch it.
- d) Wipe off water drop immediately. Long contact with water may cause discoloration or spots.
- e) When the panel surface is soiled, wipe it with absorbent cotton or other soft cloth.
- f) Since the panel is made of glass, it may break or crack if dropped or bumped on hard surface. Handle with care.
- g) Since CMOS LSI is used in this module, take care of static electricity and injure the human earth when handling. Observe all other precautionary requirements in handling components.
- h) This module has its circuitry PCBs on the side and should be handled carefully in order not to be stressed.
- i) Protect sheet(Laminate film) is attached to the module surface to prevent it from being scratched. Peel the sheet off slowly just before the use with strict attention to electrostatic charges. Ionized air shall be blown over during the action. Blow off the 'dust' on the polarizer by using an ionized nitrogen gun, etc. Working under the following environments is desirable.
 - All workers wear conductive shoes, conductive clothes, conductive fingerstalls and grounding belts without fail.
 - Use Ionized blower for electrostatic removal, and peel of the protect sheet with a constant speed. (Peeling of it at over 2 seconds)
- j) The polarizer surface on the panel is treated with Anti Glare . In case of attaching protective board over the LCD, be careful about the optical interface fringe etc. which degrades display quality.
- k) Do not expose the LCD module to a direct sunlight, for a long period of time to protect the module from the ultra violet ray.
- l) When handling LCD modules and assembling them into cabinets, please be noted that long-term storage in the environment of oxidization or deoxidization gas and the use of such materials as reagent, solvent, adhesive, resin, etc. which generate these gasses, may cause corrosion and discoloration of the LCD modules.
- m) Liquid crystal contained in the panel may leak if the LCD is broken. Rinse it as soon as possible if it gets inside your eye or mouth by mistake.
- n) Disassembling the module can cause permanent damage and should be strictly avoided.
Please don't remove the fixed tape, insulating tape etc that was pasted on the original module.
(Except for protection film of the panel.)
- o) Be careful when using it for long time with fixed pattern display as it may cause afterimage.
(Please use a screen saver etc., in order to avoid an afterimage.)
- p) If a minute particle enters in the module and adheres to an optical material, it may cause display non-uniformity issue, etc. Therefore, fine-pitch filters have to be installed to cooling and inhalation hole if you intend to install a fan.
- q) Epoxy resin (amine series curing agent), silicone adhesive material (dealcoholization series and oxime series),
tray forming agent (azo compound) etc, in the cabinet or the packing materials may induce abnormal display with polarizer film deterioration regardless of contact or noncontact to polarizer film.
Be sure to confirm the component of them.
- r) Do not use polychloroprene. If you use it, there is some possibility of generating Cl₂ gas that influences the reliability of the connection between LCD panel and driver IC.

- t) Do not put a laminate film on LCD module, after peeling of the original one. If you put on it, it may cause discoloration or spots because of the occurrence of air gaps between the polarizer and the film.
- u) Ground module bezel to stabilize against EMI and external noise.

13. Packaging Condition

Piling number of cartons	6
Package quantity in one carton	20 pcs
Carton size	550 x 450 x 233 mm
Total mass of one carton filled with full modules	10.1kg
Packing form	Fig.1

14. Label

1) Module Bar code label:

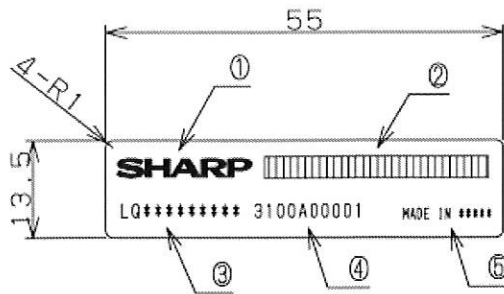

Label

	size	notes
①: SHARP logo	(3.0)	data:sharplogo
②: Bar Code (Serial Number)	-	
③: SHARP Model Number	(2.5)	
④: Serial Number	(2.0)	
⑤: Manufacturing site	(1.8)	

④Serial Number

10digits

※There is no space between characters

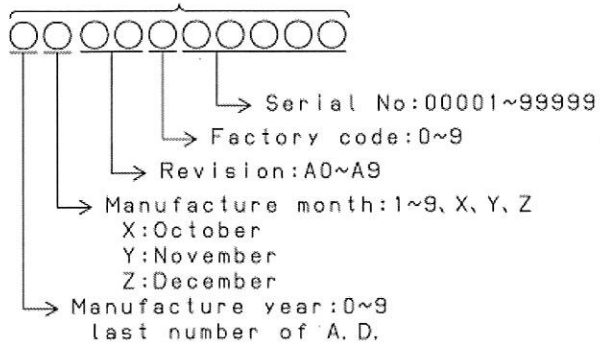

Factory code
⑤Manufacturing site

No.	Factory code	Manufacturing site
0	W-TECH	CHINA
1	*****	*****
2	*****	*****
3	*****	*****

15. RoHS Directive

This LCD module is compliant with RoHS Directive.

16. Reliability Test Items

No.	Test item	Conditions
1	High temperature storage test	Ta = 60°C 240h
2	Low temperature storage test	Ta = -20°C 240h
3	High temperature & high humidity operation test	Ta = 40°C ; 90%RH 240h (No condensation)
4	High temperature operation test	Ta = 50°C 240h
5	Low temperature operation test	Ta = 0°C 240h
6	Vibration test (non- operating)	Frequency:10~57Hz/Vibration width (one side):0.075mm :57~500Hz/acceleration:9.8m/s ² Sweep time: 11minutes Test period: 1 hour for each direction of X,Y,Z
7	Shock test (non- operating)	Max. gravity : 490 m/s ² Pulse width : 11 ms, half sine wave Direction : ±X, ±Y, ±Z once for each direction.
8	ESD	±200V, 200pF(0Ω) 1time/each terminal
9	Thermal shock	-20°C(30min)~60°C(30min), 20cycles △2

[Result Evaluation Criteria] Under the display quality test conditions with normal operation state.

Do not change these conditions as such changes may affect practical display function.

[Normal operation state] Temperature : +15~+35°C, Humidity : 45~75%, Atmospheric pressure : 86~106kPa

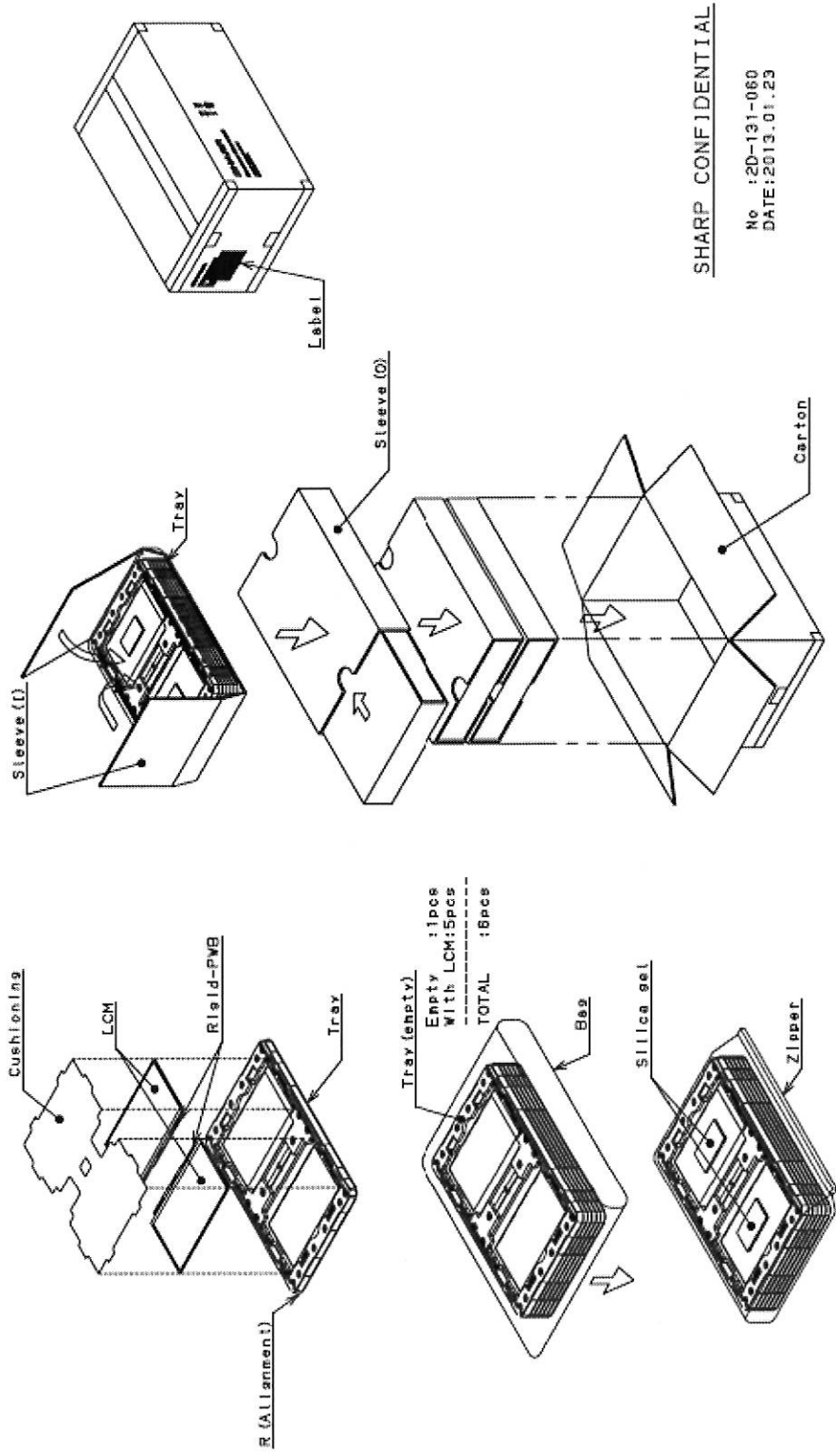

SHARP CONFIDENTIAL

No. :2D-131-060
DATE:2013.01.23

Fig. 1 Packaging Condition

△2

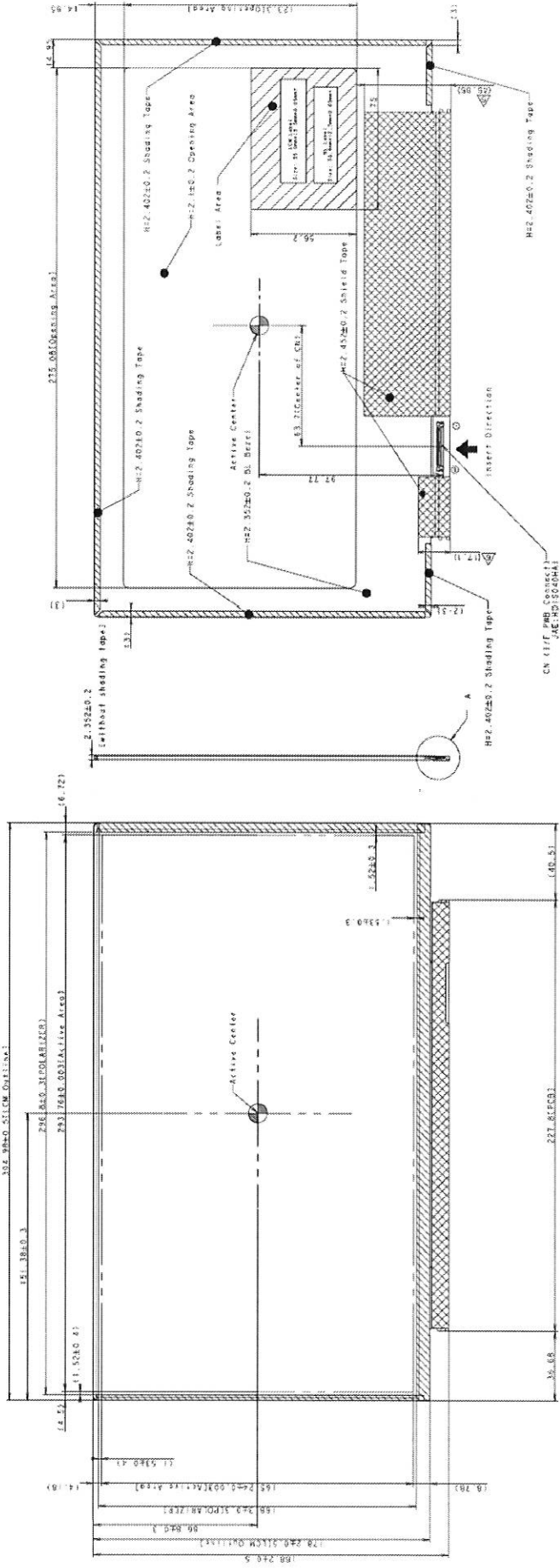

Sharp Confidential

Note
 - Unspecified tolerance to be 0.5.
 - Tolerance does not include warpage

2D-128-002-06
 Ver00:12.08.02
 Ver01:12.10.11
 Ver02:12.10.26
 Ver03:12.11.05
 Ver04:13.02.28
 Ver05:13.04.02
 Ver06:13.04.26

Fig. 2 Outline Dimensions