

PREPARED BY : DATE	<h1>SHARP</h1> <p>TFT Liquid Crystal Display Group SHARP CORPORATION</p> <h2>SPECIFICATION</h2>	SPEC No. LD-13X14
		FILE No.
APPROVED BY : DATE		ISSUE : Oct. 25, 2001
		PAGE : 20 pages
		APPLICABLE GROUP TFT Liquid Crystal Display Group

DEVICE SPECIFICATION FOR
TFT-LCD Module
 MODEL No.
LQ150X1DG91

CUSTOMER'S APPROVAL

DATE _____

BY _____

PRESENTED

BY *Makoto Takeda*

M. TAKEDA

Department General Manager

Development Engineering Department 2

TFT Division 2

TFT LIQUID CRYSTAL DISPLAY GROUP

SHARP CORPORATION

1. Application

This specifications applies to a color TFT-LCD module, LQ150X1DG91.

These specification sheets are the proprietary product of SHARP CORPORATION("SHARP) and include materials protected under copyright of SHARP. Do not reproduce or cause any third party to reproduce them in any form or by any means, electronic or mechanical, for any purpose, in whole or in part, without the express written permission of SHARP .

The device listed in these specification sheets was designed and manufactured for use in OA equipment .

In case of using the device for applications such as control and safety equipment for transportation(aircraft, trains, automobiles, etc.), rescue and security equipment and various safety related equipment which require higher reliability and safety, take into consideration that appropriate measures such as fail-safe functions and redundant system design should be taken .

Do not use the device for equipment that requires an extreme level of reliability, such as aerospace applications, telecommunication equipment(trunk lines), nuclear power control equipment and medical or other equipment for life support .

SHARP assumes no responsibility for any damage resulting from the use of the device which does not comply with the instructions and the precautions specified in these specification sheets .

Contact and consult with a SHARP sales representative for any questions about this device .

2. Overview

This module is a color active matrix LCD module incorporating amorphous silicon TFT (Thin Film Transistor). It is composed of a color TFT-LCD panel, driver ICs, control circuit, power supply circuit and a back light unit. Graphics and texts can be displayed 1024×3×768 dots on a panel with 262,144 colors by supplying 36 bit data signals(6 bit × 2pixel × RGB), four timing signals, +5V DC supply voltage for TFT-LCD panel driving and supply voltage for back light .

It is a wide viewing-angle-module (Vertical viewing angle:130 ° Horizontal viewing angle:140 °).

Input signal timing conform with 75Hz mode of VESA standard.

3. Mechanical Specifications

Parameter	Specifications	Unit
Display size	38 (Diagonal)	cm
	15.0 (Diagonal)	inch
Active area	304.1 (H) × 228.1 (V)	mm
Pixel format	1024 (H) × 768 (V)	pixel
	(1 pixel = R + G + B dots)	
Pixel pitch	0.297 (H) × 0.297 (V)	mm
Pixel configuration	R,G,B vertical stripe	
Display mode	Normally white	
Unit outline dimensions *1	331.3 (W) × 257.9 (H) × 15.9(D)	mm
Mass	1300 (max.)	g
Surface treatment	Anti-glare and hard-coating 2H (Haze value = 28)	

*1.Note: excluding back light cables .

The thickness of module (D) doesn't contain the projection .

*2.Outline dimension is shown in Fig.1

4. Input Terminals

4-1. TFT-LCD panel driving

CN1 The module-side connector : FX8-60S-SV (Hirose Electric Co., Ltd.)
 The user-side connector : FX8-60P-SV (Hirose Electric Co., Ltd.)

Pin No.	Symbol	Function	Remark	Pin No.	Symbol	Function	Remark
1	GND	GND		31	GA1	GREEN odd data signal	
2	RB0	RED even data signal (LSB)		32	GA2	GREEN odd data signal	
3	RB1	RED even data signal		33	GA3	GREEN odd data signal	
4	RB2	RED even data signal		34	GA4	GREEN odd data signal	
5	RB3	RED even data signal		35	GA5	GREEN odd data signal (MSB)	
6	RB4	RED even data signal		36	GND	GND	
7	RB5	RED even data signal (MSB)		37	BA0	BLUE odd data signal (LSB)	
8	GND	GND		38	BA1	BLUE odd data signal	
9	GB0	GREEN even data signal (LSB)		39	BA2	BLUE odd data signal	
10	GB1	GREEN even data signal		40	BA3	BLUE odd data signal	
11	GB2	GREEN even data signal		41	BA4	BLUE odd data signal	
12	GB3	GREEN even data signal		42	BA5	BLUE odd data signal (MSB)	
13	GB4	GREEN even data signal		43	GND	GND	
14	GB5	GREEN even data signal (MSB)		44	GND	GND	
15	GND	GND		45	GND	GND	
16	BB0	BLUE even data signal (LSB)		46	Vsync	Vertical synchronous signal	
17	BB1	BLUE even data signal		47	Hsync	Horizontal synchronous signal	
18	BB2	BLUE even data signal		48	ENAB	Data enable signal (Signal to settle the display position)	【Note 1】
19	BB3	BLUE even data signal		49	GND	GND	
20	BB4	BLUE even data signal		50	GND	GND	
21	BB5	BLUE even data signal (MSB)		51	CKB	Clock B signal for sampling even data signal	
22	GND	GND		52	CKA	Clock A signal for sampling odd data signal	
23	RA0	RED odd data signal (LSB)		53	GND	GND	
24	RA1	RED odd data signal		54	GND	GND (Reserve)	
25	RA2	RED odd data signal		55	GND	GND (Reserve)	
26	RA3	RED odd data signal		56	MODE	Timing signal select	【Note 1】
27	RA4	RED odd data signal		57	Vcc	+5V power supply	
28	RA5	RED odd data signal (MSB)		58	Vcc	+5V power supply	
29	GND	GND		59	Vcc	+5V power supply	
30	GA0	GREEN odd data signal (LSB)		60	Vcc	+5V power supply	

The shielding case is connected with GND in the module .

【Note 1】 In case MODE is fixed “Low”, the display start timing is determined by Vsync and ENAB.

The vertical display start position and horizontal display start position are determined as described in 7-1-2, 7-1-3. Do not keep ENAB “high” during operation.

In case MODE is fixed “High” or “Open”, the display start timing is determined by only ENAB.

4-2. Back light driving

CN2,CN3

The module-side connector : BHR-03VS-1(JST)

The user-side connector : SM02(8.0)B-BHS-1(JST)

Pin no.	symbol	function
1	V _{HIGH}	Power supply for lamp (High voltage side)
2	NC	This is electrically opened.
3	V _{LOW}	Power supply for lamp (Low voltage side)

5. Absolute Maximum Ratings

Parameter	Symbol	Condition	Ratings	Unit	Remark
Input voltage	V _I	Ta=25	- 0.3 ~ + 5.5	V	【Note1】
+5.0V supply voltage	V _{CC}	Ta=25	0 ~ + 6	V	
Storage temperature	T _{stg}	-	- 25 ~ + 60		【Note2】
Operating temperature (Ambient)	T _{opa}	-	0 ~ + 50		

【Note1】 CKA, CKB, RA0 ~ RA5, GA0 ~ GA5, BA0 ~ BA5, RB0 ~ RB5, GB0 ~ GB5, BB0 ~ BB5,

Hsync, Vsync, ENAB, MODE

【Note2】 Humidity : 95%RH Max. (Ta 40)

Maximum wet-bulb temperature at 39 or less (Ta>40)

No condensation.

6. Electrical Characteristics

6-1. TFT-LCD panel driving

Ta = 25

Parameter		Symbol	Min.	Typ.	Max.	Unit	Remark
Vcc	Supply voltage	Vcc	+4.5	+5.0	+5.5	V	【Note1】
	Current dissipation	Icc	-	300	450	mA	【Note2】
Permissive input ripple voltage		V _{RF}	-	-	100	mVp-p	Vcc=+5.0V
Input voltage (Low)		V _{IL}	GND	-	0.6	V	【Note3】
Input voltage (High)		V _{IH}	2.6	-	Vcc	V	【Note3】
Input current (Low)		I _{IL}	-	-	10	μA	V _I =GND 【Note3】
			-	-	400	μA	V _I =GND 【Note4】
Input current (High)		I _{IH}	-	-	10	μA	V _I =Vcc 【Note3】
			-	-	600	μA	V _I =Vcc 【Note4】

3.3(v) logic is recommended as input signals .

【Note1】

On-off conditions for supply voltage

0 < t1 10ms

t4 1s

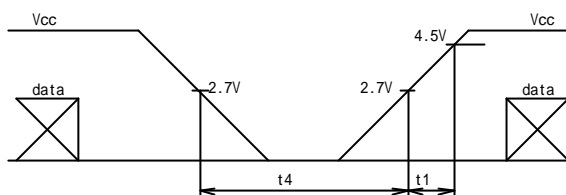

Vcc-dip conditions

1) 2.7V Vcc < 4.5V

td 10ms

2) Vcc < 2.7V

Vcc-dip conditions should also follow the on-off conditions

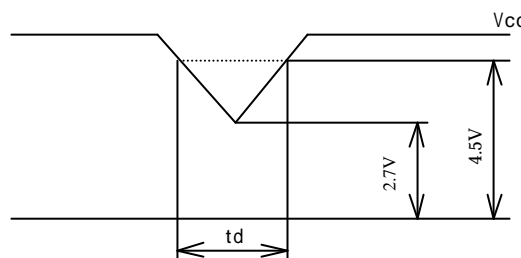

【Note2】 Typical current situation : 16-gray-bar pattern.

Vcc=+5.0V,

Gray scale : GS(4n)

n=0 ~ 15

The explanation of each gray scale ,GS(4n), is described below section (8).

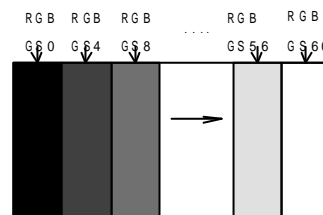

【Note3】 CKA, CKB, RA0 ~ RA5, GA0 ~ GA5, BA0 ~ BA5, RB0 ~ RB5, GB0 ~ GB5, BB0 ~ BB5,

Hsync, Vsync, ENAB

【Note4】 MODE

Input circuit of MODE is shown in right figure.

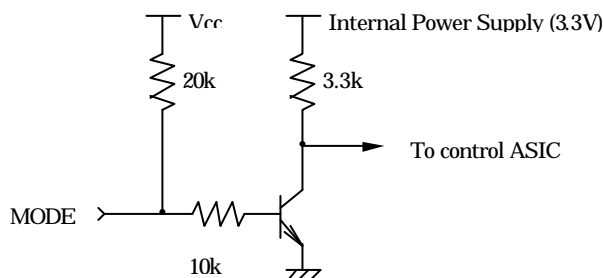

6-2. Back light driving

The back light system is an edge-lighting type with a couple of CCFT (Cold Cathode Fluorescent Tube). The characteristics of the lamp are shown in the following table .

The value mentioned below is at the case of one CCFT .

CCFT Model Name : K-CT321-B-91CH (West Electric Co.,Ltd)

Parameter	Symbol	Min.	Typ.	Max.	Unit	Remark
Lamp current range	I_L	3.0	7.5	8.0	mArms	【Note1】
Lamp voltage	V_L	-	675	-	Vrms	Ta=25
Lamp power consumption	P_L	-	5.1	-	W	【Note2】
Lamp frequency	F_L	35	60	70	KHz	【Note3】
Kick-off voltage	V_s	-	-	850	Vrms	Ta=25 【Note4】
		-	-	1450	Vrms	Ta=0 【Note4】
Lamp life time	L_L	30000	-	-	hour	【Note5】

【Note1】 A lamp can be light in the range of lamp current shown above .

Maximum rating for current is measured by high frequency current measurement equipment connected to V_{LOW} at circuit showed below . (Note : To keep enough kick-off voltage and necessary steady voltage for CCFT .)

Lamp frequency : 35 ~ 70kHz

Ambient temperature : 0 ~ 50

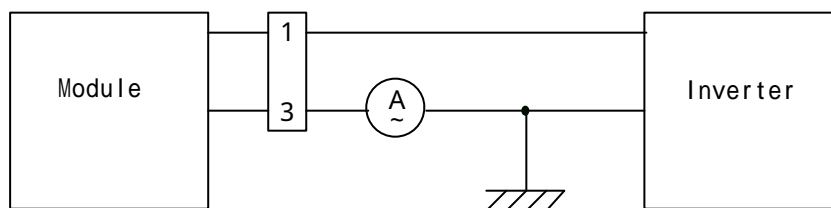

* 3pin is V_{LOW}

【Note2】 Referential data per one CCFT by calculation ($I_L \times V_L$).

The data doesn't include loss at inverter .

【Note3】 Lamp frequency of inverter may produce interference with horizontal synchronous frequency, and this may cause horizontal beat on the display. Therefore, adjust lamp frequency, and keep inverter as far as from module or use electronic shielding between inverter and module to avoid interference.

【Note4】 Kick-off voltage value is described as the index in the state of lamp only.

The kick-off voltage is estimated to be risen up as approx. +200V in the state of module only, and the further rise up can be seen according to the assembling status of user cabinet. Please set the kick-off voltage of inverter to avoid the lighting failures in the state of operation. Please design the inverter so that its open output voltage can be connected for more than 1 second to startup. Otherwise, the lamp may not be turned on. But, please set as 100ms when the ambient luminance around the lamp is more than 1 lux.

【Note5】 Lamp life time is defined as the time when either or occurs in the continuous operation under the condition of $T_a=25$ and $I_L=7.5\text{mA}_{\text{rms}}$.

Brightness becomes 50% of the original value under standard condition.

Kick-off voltage at $T_a=0$ exceeds maximum value, $1450\text{V}_{\text{rms}}$.

《Note》 The performance of the back light, for example life time or brightness, is much influenced by the characteristics of the DC-AC inverter for the lamp .When you design or order the inverter, please make sure that a poor lighting caused by the mismatch of the back light and the inverter (miss-lighting, flicker, etc.) never occurs. When you confirm it, the module should be operated in the same condition as it is installed in your instrument.

Use the lamp inverter power source incorporating such safeguard as overvoltage / overcurrent protective circuit or lamp voltage waveform detection circuit, which should have individual control of each lamp. In case one circuit without such individual control is connected to more than two lamps, excessive current may flow into one lamp when the other one is not in operation.

7. Timing characteristics of input signals

7-1. H-V mode (MODE = “Low”)

Timing diagrams of input signal are shown in Fig.2 .

7-1-1. Timing characteristics

Parameter		Symbol	Min.	Typ.	Max.	Unit	Remark
Clock A	Frequency	1/Tc	25	32.5	40	MHz	
	Clock B	High time	Tch	9	-	-	ns
Low time		Tcl	9	-	-	ns	
Duty ratio		Tch/ Tcl	0.67	1.00	1.50	-	
Data	Setup time	Tds	5	-	-	ns	
	Hold time	Tdh	5	-	-	ns	
Horizontal sync. signal	Cycle	TH	16.6	20.7	-	μs	
			528	672	860	clock	
	Pulse width	THp	2	68	-	clock	
Horizontal data start		THbp	-	148	-	clock	
Hsync-Clock phase difference		TFc	5	-	-	ns	
Vertical sync. signal	Cycle	TV	-	16.7	-	ms	【Note1】
			773	806	990	line	
	Pulse width	TVp	1	6	-	line	
Vertical data start		TVbp	35	35	35	line	
Hsync-Vsync phase difference		TVh	1	-	TH-THp	clock	

【Note1】 In case of lower frequency, the deterioration of display quality, flicker etc may be occurred .

7-1-2. Horizontal display position

The horizontal display position is determined by ENAB signal and the input data corresponding to the rising edge of ENAB signal is displayed at the left end of the active area .

Parameter		symbol	Min.	Typ.	Max.	Unit	Remark
ENAB signal	Setup time	Tes	5	-	Tc-10	ns	
	Pulse width	Tep	10	512	512	clock	
Hsync-ENAB phase difference		THE	THp+1	148	TH-512	clock	

Do not keep ENAB “Low” during operation.

7-1-3. Vertical display position

The vertical display start position is the 35th line from the falling edge of Vsync .(cf. Fig.2)

7-2. ENAB mode (MODE = “High” or “Open”)

Timing diagrams of input signal are shown in Fig.3.

7-2-1. Timing characteristics

	Parameter	Symbol	Min.	Typ.	Max.	Unit
Clock A	Frequency	1/Tc	25	32.5	40	MHz
	Clock B	High time	Tch	9	-	-
Low time		Tcl	9	-	-	ns
Duty ratio		Tch/ Tcl	0.67	1.00	1.50	-
Phase difference		Tcp	-4	0	+4	ns
Data		Setup time	Tds	5	-	-
	Hold time	Tdh	5	-	-	ns
Data enable signal	Setup time	Tes	5	-	Tc-10	ns
	Horizontal period	TH	16.6	20.7	-	μs
			528	672	860	clock
	Horizontal period (High)	THp	10	512	512	clock
	Vertical period	TV	770	806	990	line
	Vertical blanking width	TVb	2	38	222	line

【Note】 In case of using the long vertical period, the deterioration of display quality, flicker etc., may be occurred.

7-3. Input Data Signals and Display Position on the screen

Graphics and texts can be displayed 1024 × 3 × 768 dots on a panel with 262,144 colors by supplying 36 bit data signal (6bit/color [64 gray scale] x 3 x 2 pixels) .

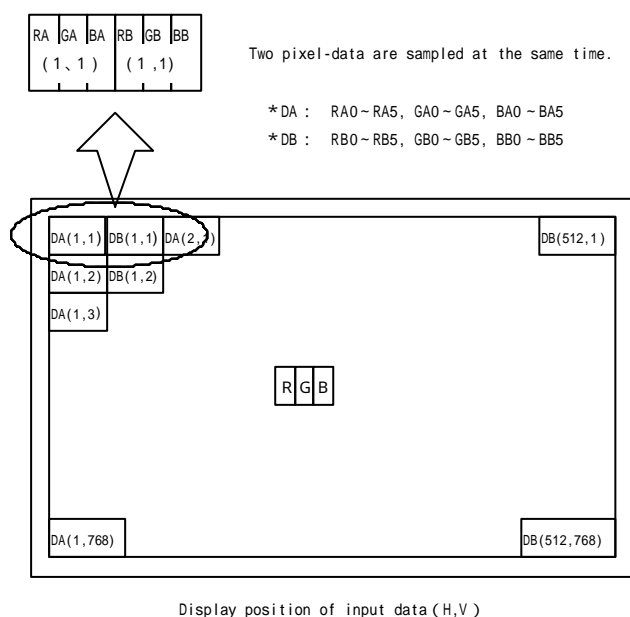

7-4. Sleep Mode

This LCD module stops operation, and the picture of the LCD module becomes wholly white, if ENAB signal stays "Low" for over 0.5 sec. Follow the above input signal timing for normal operation.

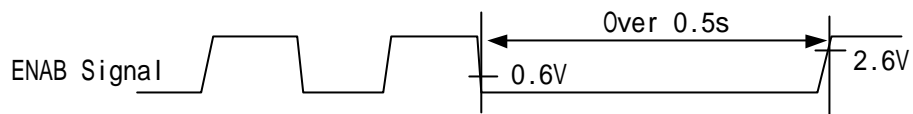

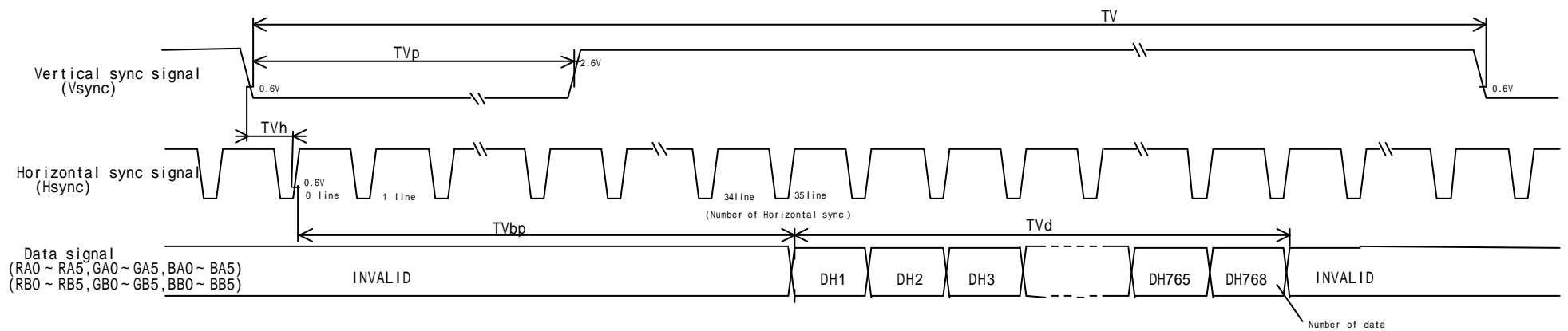
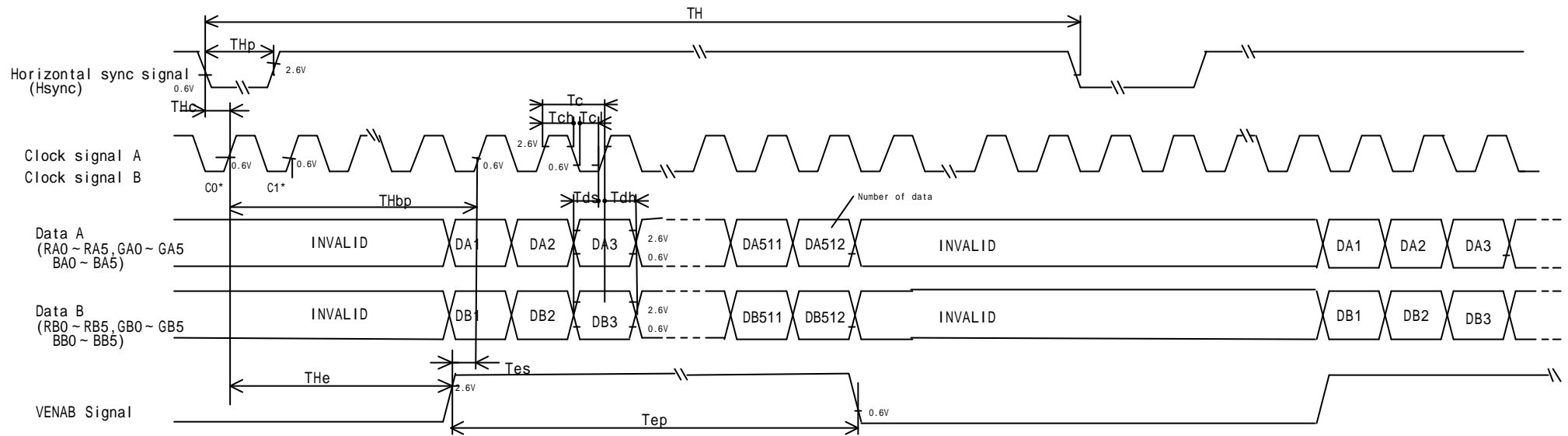

Fig.2 Input Signal Waveforms(H-V Mode)

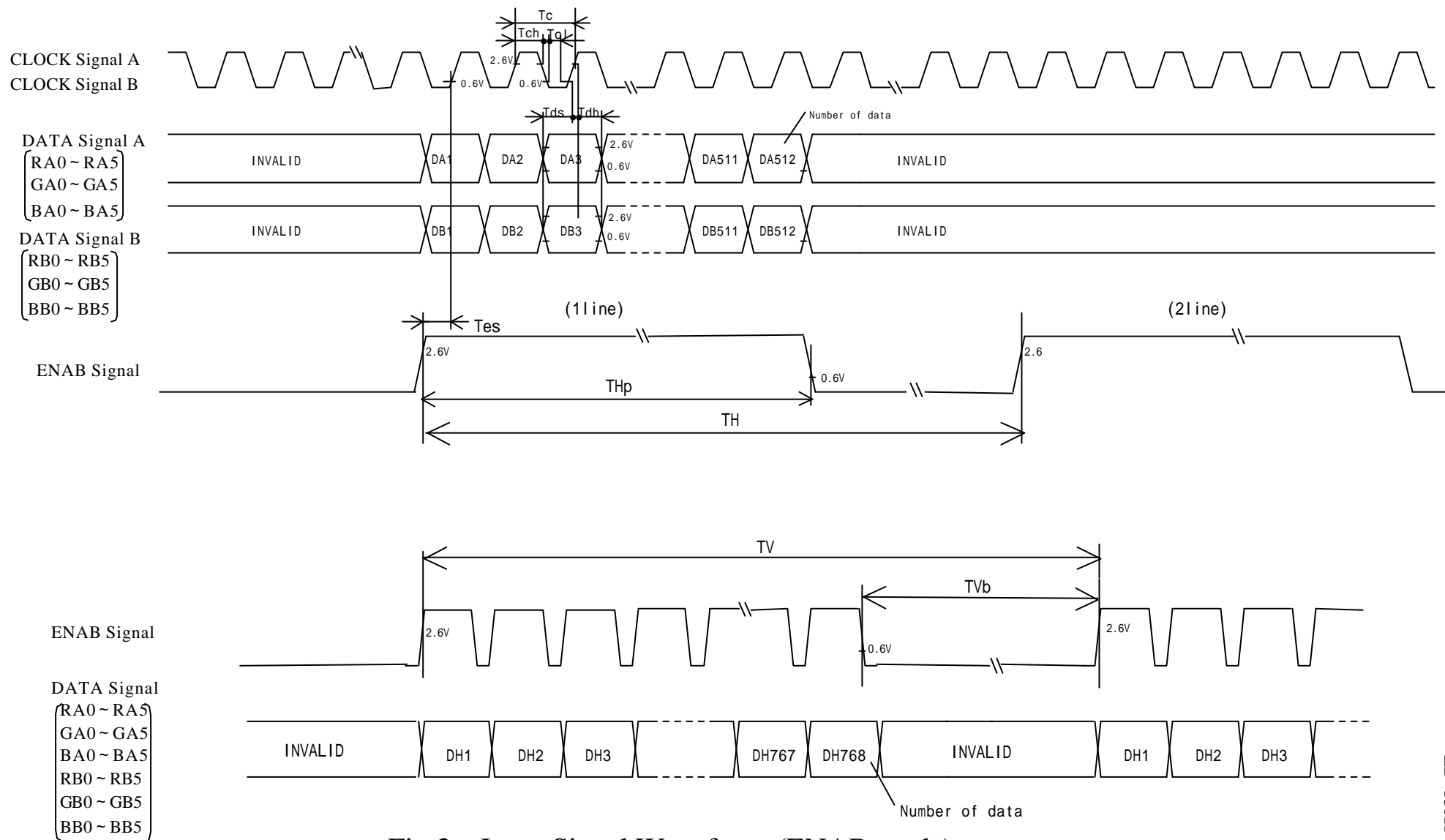

Fig.3 Input Signal Waveforms(ENAB mode)

8. Input Signals, Basic Display Colors and Gray Scale of Each Color

	Colors & Gray scale	Data signal																		
		Gray Scale	RA0	RA1	RA2	RA3	RA4	RA5	GA0	GA1	GA2	GA3	GA4	GA5	BA0	BA1	BA2	BA3	BA4	BA5
			RB0	RB1	RB2	RB3	RB4	RB5	GB0	GB1	GB2	GB3	GB4	GB5	BB0	BB1	BB2	BB3	BB4	BB5
Basic Color	Black	-	0	0	0	0	0	0	0	0	0	0	0	0	0	0	0	0	0	0
	Blue	-	0	0	0	0	0	0	0	0	0	0	0	0	1	1	1	1	1	1
	Green	-	0	0	0	0	0	0	1	1	1	1	1	1	0	0	0	0	0	0
	Cyan	-	0	0	0	0	0	0	1	1	1	1	1	1	1	1	1	1	1	1
	Red	-	1	1	1	1	1	1	0	0	0	0	0	0	0	0	0	0	0	0
	Magenta	-	1	1	1	1	1	1	0	0	0	0	0	0	1	1	1	1	1	1
	Yellow	-	1	1	1	1	1	1	1	1	1	1	1	1	0	0	0	0	0	0
	White	-	1	1	1	1	1	1	1	1	1	1	1	1	1	1	1	1	1	1
Gray Scale of Red	Black	GS0	0	0	0	0	0	0	0	0	0	0	0	0	0	0	0	0	0	0
	↑	GS1	1	0	0	0	0	0	0	0	0	0	0	0	0	0	0	0	0	0
	Darker	GS2	0	1	0	0	0	0	0	0	0	0	0	0	0	0	0	0	0	0
	↑	↓			↓					↓					↓					
	↓	↓			↓					↓					↓					
	Brighter	GS61	1	0	1	1	1	1	0	0	0	0	0	0	0	0	0	0	0	0
	↓	GS62	0	1	1	1	1	1	0	0	0	0	0	0	0	0	0	0	0	0
	Red	GS63	1	1	1	1	1	1	0	0	0	0	0	0	0	0	0	0	0	0
Gray Scale of Green	Black	GS0	0	0	0	0	0	0	0	0	0	0	0	0	0	0	0	0	0	0
	↑	GS1	0	0	0	0	0	0	1	0	0	0	0	0	0	0	0	0	0	0
	Darker	GS2	0	0	0	0	0	0	0	1	0	0	0	0	0	0	0	0	0	0
	↑	↓			↓					↓					↓					
	↓	↓			↓					↓					↓					
	Brighter	GS61	0	0	0	0	0	0	1	0	1	1	1	1	0	0	0	0	0	0
	↓	GS62	0	0	0	0	0	0	0	1	1	1	1	1	0	0	0	0	0	0
	Green	GS63	0	0	0	0	0	0	1	1	1	1	1	1	0	0	0	0	0	0
Gray Scale of Blue	Black	GS0	0	0	0	0	0	0	0	0	0	0	0	0	0	0	0	0	0	0
	↑	GS1	0	0	0	0	0	0	0	0	0	0	0	0	1	0	0	0	0	0
	Darker	GS2	0	0	0	0	0	0	0	0	0	0	0	0	0	1	0	0	0	0
	↑	↓			↓					↓					↓					
	↓	↓			↓					↓					↓					
	Brighter	GS61	0	0	0	0	0	0	0	0	0	0	0	0	1	0	1	1	1	1
	↓	GS62	0	0	0	0	0	0	0	0	0	0	0	0	0	1	1	1	1	1
	Blue	GS63	0	0	0	0	0	0	0	0	0	0	0	0	1	1	1	1	1	1

0 : Low level voltage, 1 : High level voltage

Each basic color can be displayed in 64 gray scales from 6 bit data signals. According to the combination of total 18 bit data signals, the 262,144-color display can be achieved on the screen.

9. Optical Characteristics

Ta=25 , Vcc=+5V

Parameter		Symbol	Condition	Min.	Typ.	Max.	Unit	Remark		
Viewing angle range	Vertical	11	CR 5	50	65	-	Deg.	【Note1,4】		
		12		50	65	-	Deg.			
	Horizontal	21, 22	60	70	-	Deg.				
	Vertical	11	CR 10	40	50	-	Deg.			
		12		40	50	-	Deg.			
Horizontal	21, 22	50	65	-	Deg.					
Contrast ratio		CR	=0 °	250	350	-	-	【Note2,4】		
Response Time	Rise	r	=0 °	-	5	20	m s	【Note3,4】		
	Decay	d		-	30	45	m s			
Chromaticity of White		x	=0 °	0.283	0.313	0.343	-	【Note4】		
		y		0.299	0.329	0.359	-			
Chromaticity of Red		x		0.554	0.584	0.614	-			
		y		0.301	0.331	0.361	-			
Chromaticity of Green		x		0.270	0.300	0.330	-			
		y		0.535	0.565	0.595	-			
Chromaticity of Blue		x		0.115	0.145	0.175	-			
		y		0.094	0.124	0.154	-			
Luminance of white		YL			200	250	-		cd/m ²	IL =7.5mA rms FL =60kHz 【Note4】
White Uniformity		w5			-	-	1.35		-	【Note5】

The measurement shall be executed 30 minutes after lighting at rating .

(typical condition:IL=7.5mArms)

The optical characteristics shall be measured in a dark room or equivalent state with the method shown in Fig.4 below .

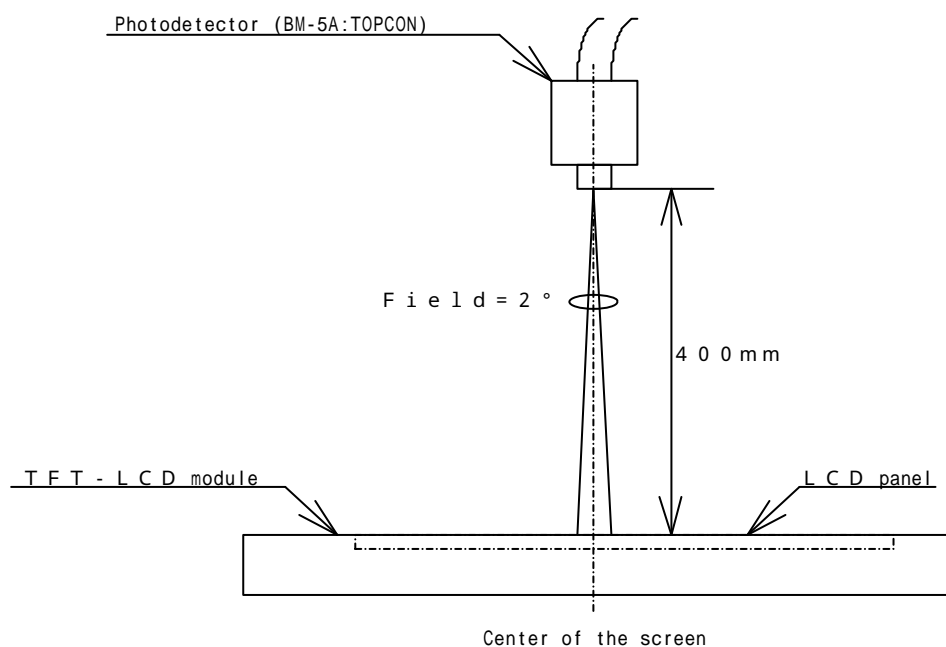
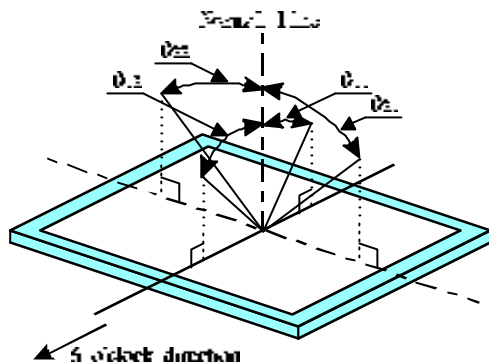

Fig.4 Optical characteristics measurement method

【Note1】 Definitions of viewing angle range:



【Note2】 Definition of contrast ratio:

The contrast ratio is defined as the following .

$$\text{Contrast Ratio (CR)} = \frac{\text{Luminance (brightness) with all pixels white}}{\text{Luminance (brightness) with all pixels black}}$$

【Note3】 Definition of response time:

The response time is defined as the following figure and shall be measured by switching the input signal for "black" and "white" .

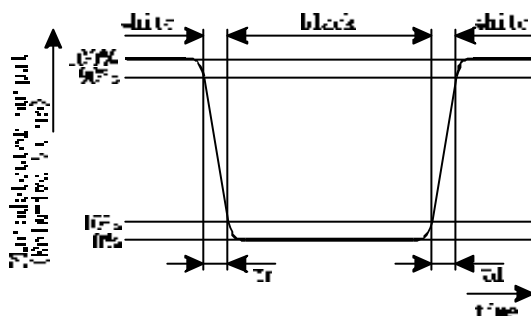

【Note4】 This shall be measured at center of the screen .

【Note5】 Definition of white uniformity:

White uniformity is defined as the following with five measurements (A ~ E) .

$$w = \frac{\text{Maximum Luminance of five points (brightness)}}{\text{Minimum Luminance of five points (brightness)}}$$

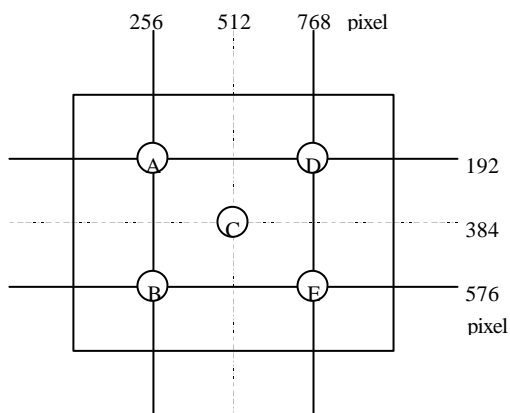

10. Handling Precautions

- a) Be sure to turn off the power supply when inserting or disconnecting the cable.
- b) Be sure to design the cabinet so that the module can be installed without any extra stress such as warp or twist.
- c) Since the front polarize is easily damaged, pay attention not to scratch it.
- d) Since long contact with water may cause discoloration or spots, wipe off water drop immediately.
- e) When the panel surface is soiled, wipe it with absorbent cotton or other soft cloth.
- f) Since the panel is made of glass, it may break or crack if dropped or bumped on hard surface. Handle with care.
- g) Since CMOS LSI is used in this module, take care of static electricity and take the human earth into consideration when handling.
- h) Make sure the four mounting holes of the module are grounded sufficiently. Take electro-magnetic interference (EMI) into consideration.
- i) The module has some printed circuit boards (PCBs) on the back side. Take care to keep them from any stress or pressure when handling or installing the module; otherwise some of electronic parts on the PCBs may be damaged.
- j) Observe all other precautionary requirements in handling components.
- k) When some pressure is added onto the module from rear side constantly , it causes display non-uniformity issue , functional defect , etc . So , please avoid such design .
- l) When handling LCD modules and assembling them into cabinets, please be noted that long-term storage in the environment of oxidization or deoxidization gas and the use of such materials as reagent, solvent, adhesive, resin, etc. which generate these gasses, may cause corrosion and discoloration of the LCD modules.

11. Packing form

- a) Piling number of cartons : Max. 5 cartons
- b) Packing quantity in one carton : 5 module
- c) Carton size : 420 (W) × 500 (D) × 270 (H)
- d) Total mass of one carton filled with full modules : Max. 8700g

Packing form is shown in Fig .5

12 . Reliability test items

No.	Test item	Conditions
1	High temperature storage test	Ta = 60 240h
2	Low temperature storage test	Ta = -25 240h
3	High temperature & high humidity operation test	Ta = 40 ; 95%RH 240h (No condensation)
4	High temperature operation test	Ta = 50 240h (The panel temp. must be less than 60)
5	Low temperature operation test	Ta = 0 240H
6	Vibration test (non- operating)	Frequency : 10 ~ 57Hz/Vibration width (one side) : 0.075mm : 58 ~ 500Hz/Gravity : 9.8m/s ² Sweep time : 11 minutes Test period : 3 hours (1 hour for each direction of X,Y,Z)
7	Shock test (non- operating)	Max. gravity : 490m/s ² Pulse width : 11ms, sine wave Direction : ± X, ± Y, ± Z, once for each direction.

【 valuation method 】

Module test is done in standard condition, under the inspection standard of the shipment inspection standard book.
We consider which there is the change that becomes an obstruction on practical use or not.

13 . Others

1) Lot No. and indication Bar Code Label:

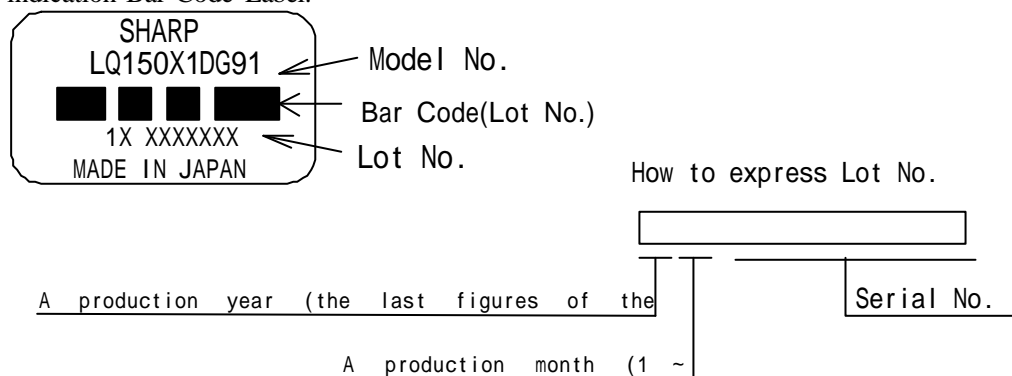

- 2) Adjusting volume have been set optimally before shipment, so do not change any adjusted value.
If adjusted value is changed, the specification may not be satisfied.
- 3) Disassembling the module can cause permanent damage and should be strictly avoided.
- 4) Please be careful since image retention may occur when a fixed pattern is displayed for a long time.
- 5) The chemical compound which causes the destruction of ozone layer is not being used.

6) Warning of mercury and material information of LPG(Light Pipe Guide) are labeled on the back of the module.

<p>MATERIAL INFORMATION >PLASTIC LIGHT GUIDE:PMMA<</p>
--

7)Cold cathode fluorescent lamp in LCD PANEL contains a small amount of mercury, Please follow local ordinances or regulations for disposal. (put on the back of the module. :Size: 63 × 14mm)

<p>COLD CATHODE FLUORESCENT LAMP IN LCD PANEL CONTAINS A SMALL AMOUNT OF MERCURY, PLEASE FOLLOW LOCAL ORDINANCES OR REGULATION FOR DISPOSAL 当該液晶ディスプレイパネルは蛍光管が組み込まれていますので、地方自治 体の条例、または、規則に従って廃棄ください。</p>

8) When any question or issue occurs, it shall be solved by mutual discussion.

Carton storage condition

Temperature	0 to 40
Humidity	95%RH or less
Reference condition :	20 to 35 , 85%RH or less (summer) : 5 to 15 , 85%RH or less (winter) • the total storage time (40 ,95%RH) : 240H or less
Sunlight	Be sure to shelter a product from the direct sunlight.
Atmosphere	Harmful gas, such as acid and alkali which bites electronic components and/or wires, must not be detected.
Notes	Be sure to put cartons on palette or base, don't put it on floor, and store them with removing from wall Please take care of ventilation in storehouse and around cartons, and control changing temperature is within limits of natural environment
Storage period	1 year

CCFT CONNECTOR
CN2: BHR-03VS-1 (JST)
PIN LAYOUT

1	High
2	NC
3	GND

NOTES

1. UNSPECIFIED TOLERANCE TO BE ±0.5
2. WARP AND FLATING FOR PCB AND CHASSIS ARE EXCLUDED FROM THICKNESS AND DIMENSION OF THE UNIT.
3. THE THICKNESS IS EXCEPT FOR PORTION OF PROJECTION. (*A & *B)

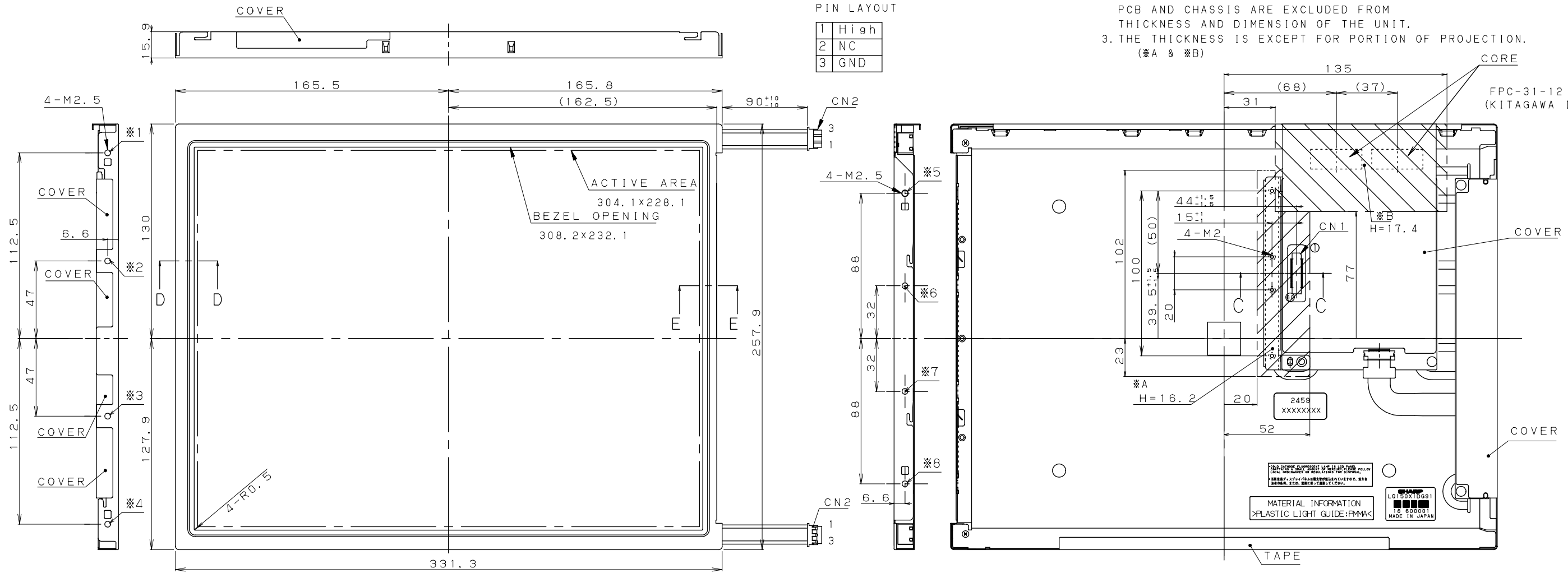

*1~*8
•FOR USER USE
TIGHTEN TORQUE :MAX
0.294±0.02 N·m
(3.0±0.2 Kgf·cm)

INTERFACE CONNECTOR
CN1: FX8-60S-SV (HIROSE)
PIN LAYOUT (60pins)

pin	1	2	3	4	5	6	7	8	9	10	11	12	13	14	15
	GND	RB0	RB1	RB2	RB3	RB4	RB5	GND	GB0	GB1	GB2	GB3	GB4	GB5	GND
16	17	18	19	20	21	22	23	24	25	26	27	28	29	30	31
BB0	BB1	BB2	BB3	BB4	BB5	GND	RA0	RA1	RA2	RA3	RA4	RA5	GND	GA0	GA1
32	33	34	35	36	37	38	39	40	41	42	43	44	45	46	47
GA2	GA3	GA4	GA5	GND	BA0	BA1	BA2	BA3	BA4	BA5	GND	GND	GND	VS	HS
48	49	50	51	52	53	54	55	56	57	58	59	60	*	*	*
DE	GND	GND	CLK-B	CLK-A	GND	GND	GND	MODE	VCC	VCC	VCC	VCC	*	*	*

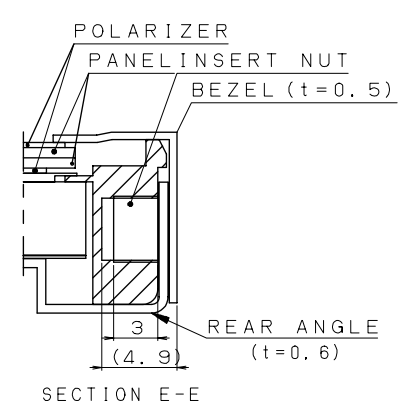
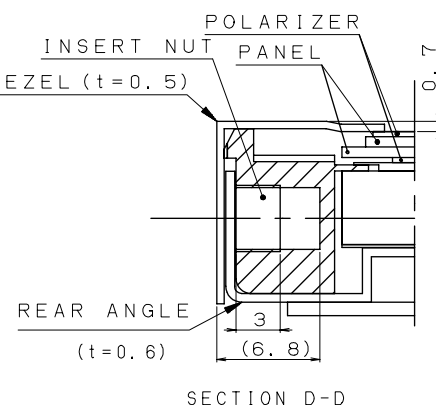
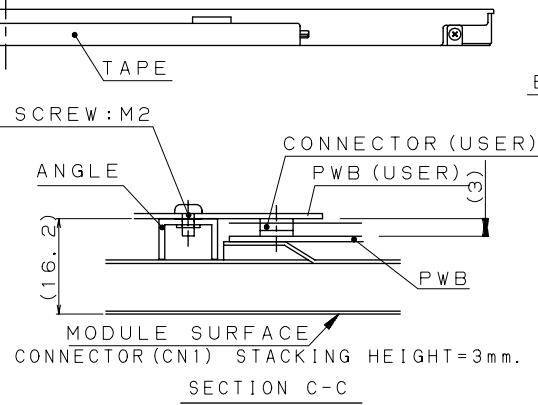

BEZEL/DISPLAY POSITION

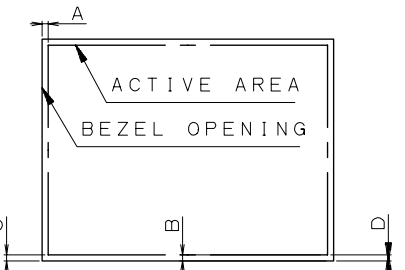

- 1) TOLERANCE X-DIRECTION A: 2±0.8
- 2) TOLERANCE Y-DIRECTION B: 2±0.8
- 3) OBLIQUITY OF DISPLAY AREA IC-DI < 0.8

Fig1. OUTLINE DIMENSIONS (LQ150X1DG91)

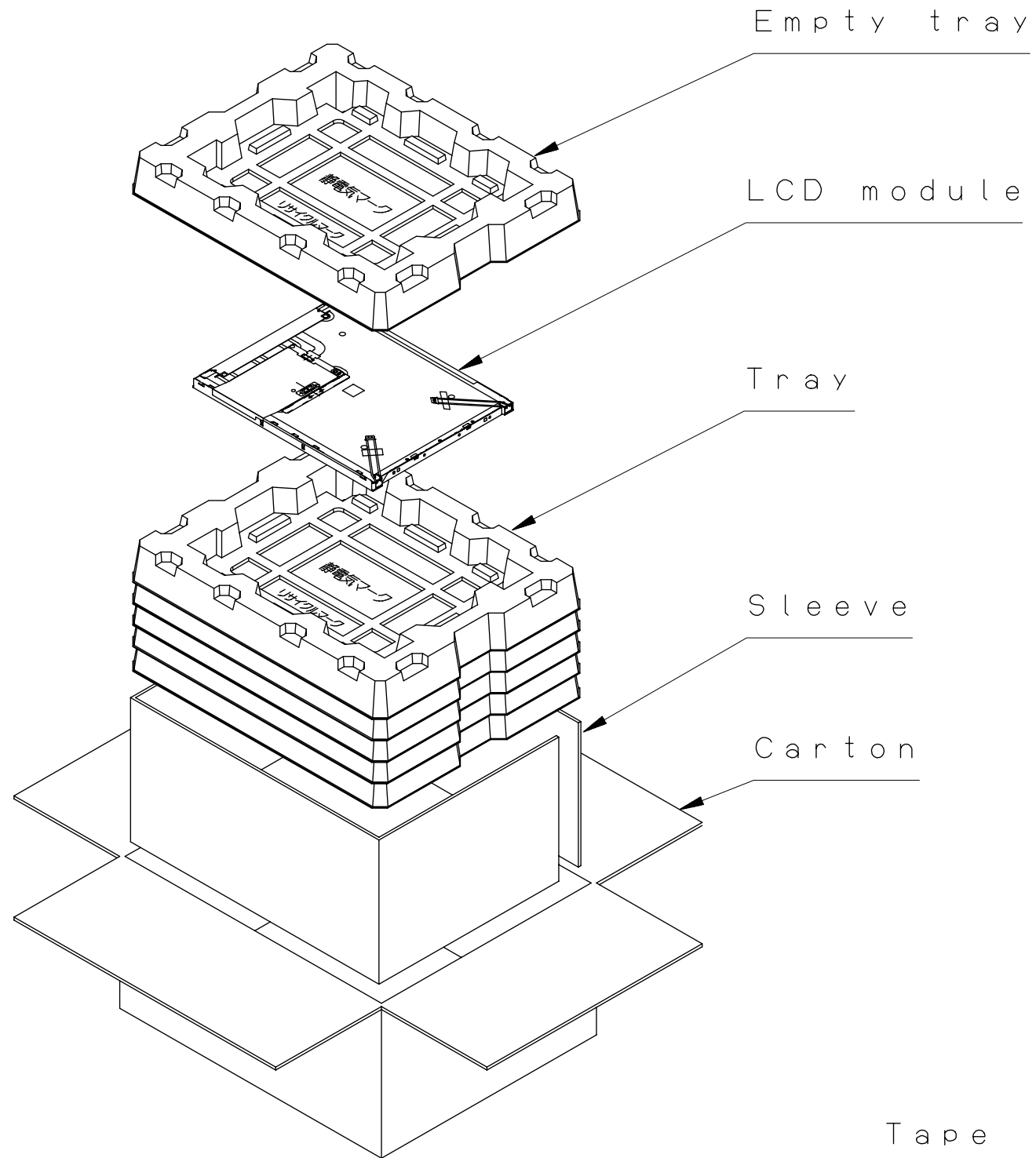

-Packing barcode label-

社内品番: (4S) LQ150X1DG91	← ①
<input type="text"/>	
LotNO. : (1T) 2001.10.25 1	← ②
<input type="text"/>	
Quantity: (Q) 5 pcs	← ③
<input type="text"/>	
ユーザー品番 :	← ④
<input type="text"/>	
シャープ物流用ラベルです。	← ⑤

- ② Lot No. (Date)
- ③ Quantity
- ④ User model No.
- ⑤ Sharp model No.

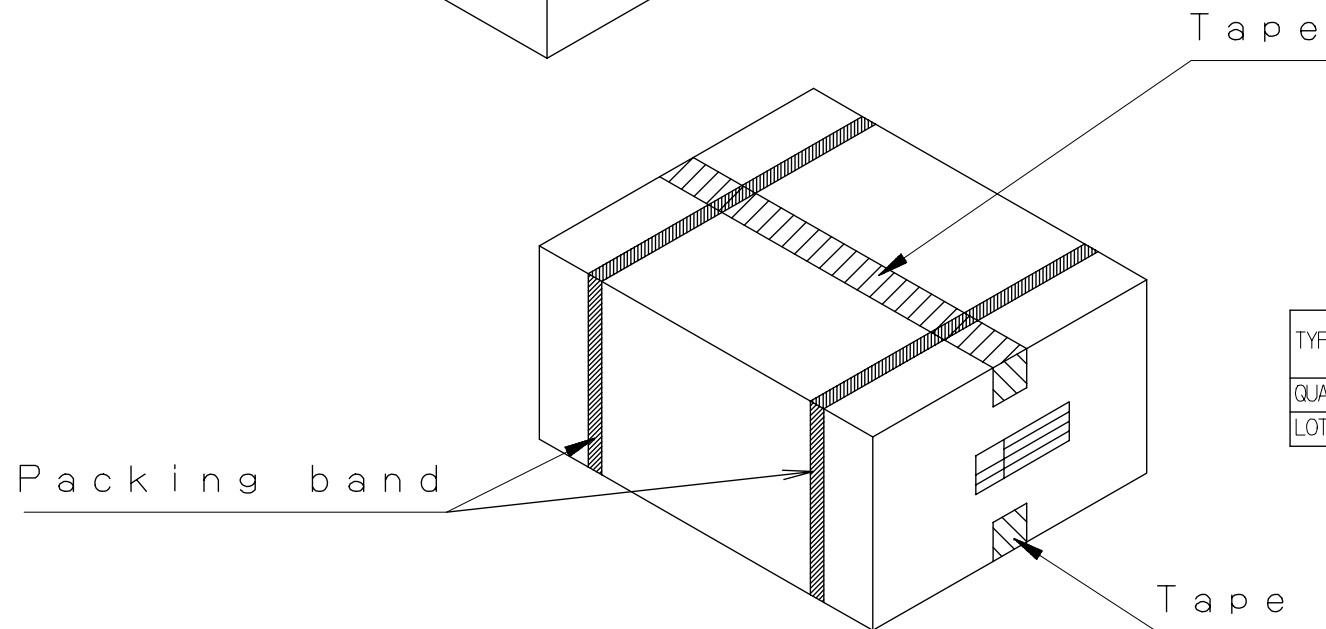

TYPE	
QUANTITY	
LOT (DATE)	

Barcode label

Fig. 5 PACKING FORM