

PREPARED BY : DATE	<h1>SHARP</h1> <p>MOBILE LIQUID CRYSTAL DISPLAY GROUP SHARP CORPORATION</p> <h2>SPECIFICATION</h2>	SPEC No. LD-19509C
APPROVED BY : DATE		FILE No.
		ISSUE : May. 18. 2007
		PAGE : 24 pages
		APPLICABLE GROUP
		MOBILE LIQUID CRYSTAL DISPLAY GROUP

REVISION: Jun. 22. 2007

DEVICE SPECIFICATION FOR
TFT-LCD Module
 MODEL No.
LQ150X1LG45

These parts have corresponded with the RoHS directive.

CUSTOMER'S APPROVAL

BY _____

BY *K. Shiono*

K. Shiono
 General manager
 ENGINEERING DEPARTMENT
 MOBILE LIQUID CRYSTAL DISPLAY DIVISION III
 MOBILE LIQUID CRYSTAL DISPLAY GROUP
 SHARP CORPORATION

RECORDS OF REVISION

LQ150X1LG45

SPEC No.	DATE	REVISED No.	PAGE	SUMMARY	NOTE
LD-19509A	May. 18. 2007	-	-	-	1 st Issue
LD-19509B	Jun. 14. 2007	△ 1	4, 5,	LVDS_SET	
			6, 7	Change : L(GND or Open) → L(GND)	
			9	7-1. TFT-LCD panel driving Change : Value of " VIL(max)"	
			9	6. Recommended operation condition Change : 【Note3】	
			10	7-2. Backlight Change : Description method of " Life time"	
			15	10. Optical Characteristics Change : Value of " Chromaticity of Green"	
			20	14-1. Lot No. Label Delete : security label	
21	Fig1. Outline Dimensions Change : Hole depth, shape of bezel Delete : security label Add : slit of bezel				
LD-19509C	Jun. 22. 2007	△ 2	8	5. Absolute Maximum Ratings Change : Value of " Input voltage" Change : Description method of " Topa"	
			9	【Note1】 Vcc-dip conditions Change : 1) $2.5V \leq V_{cc} \rightarrow 2.5V \leq V_{cc} < 3.0V$	
			9	【Note4】 Add : notice	
			10	7-2. Backlight IL Change : Max. 7.0 → 7.5	
			10	7-2. Backlight VL Change : Remark 60kHz → 55kHz Change : 【Note2】 $IL = 6.0mA_{rms} \rightarrow 6.5mA_{rms}$	
			13	9-1. 8bit input Change : R0, R1, G0, G1, B0, B1 of Basic Color	
			15	10. Optical Characteristics Change : Value of " White Uniformity"	
			16	【Note5】 Change : Definition of white uniformity	

1. Application

This specification applies to the color 15.0 XGA TFT-LCD module LQ150X1LG45

These specification sheets are the proprietary product of SHARP CORPORATION("SHARP) and include materials protected under copyright of SHARP. Do not reproduce or cause any third party to reproduce them in any form or by any means, electronic or mechanical, for any purpose, in whole or in part, without the express written permission of SHARP.

The device listed in these specification sheets was designed and manufactured for use in general electronic equipment.

In case of using the device for applications such as control and safety equipment for transportation (controls of aircraft, trains, automobiles, etc.), rescue and security equipment and various safety related equipment which require higher reliability and safety, take into consideration that appropriate measures such as fail-safe functions and redundant system design should be taken.

Do not use the device for equipment that requires an extreme level of reliability, such as aerospace applications, telecommunication equipment(trunk lines), nuclear power control equipment and medical or other equipment for life support.

SHARP assumes no responsibility for any damage resulting from the use of the device which does not comply with the instructions and the precautions specified in these specification sheets.

Confirm "11. Handling Precautions " item when you use the device.

Contact and consult with a SHARP sales representative for any questions about this device.

2. Overview

This module is a color active matrix LCD module incorporating amorphous silicon TFT (Thin Film Transistor). It is composed of a color TFT-LCD panel, driver ICs, control circuit, power supply circuit and a back light unit. Graphics and texts can be displayed on a 1024× RGB× 768 dots panel with about 16 million colors by using LVDS (Low Voltage Differential Signaling) and supplying +3.3V DC supply voltages for TFT-LCD panel driving and supply voltage for backlight. Backlight-driving DC/AC inverter is not built in this module. This TFT-LCD module conforms to PSWG. Viewing angle is 6 o'clock direction.

3. Mechanical Specifications

Parameter	Specifications	Unit
Display size	38 (Diagonal)	cm
	15.0 (Diagonal)	Inch
Active area	304.1 (H)× 228.1 (V)	mm
Pixel format	1024 (H)× 768 (V)	Pixel
	(1 pixel = R+G+B dots)	
Pixel pitch	0.297 (H)× 0.297 (V)	mm
Pixel configuration	R, G, B vertical stripe	
Display mode	Normally white	
Unit outline dimensions *1	326.5(W)× 253.5(H)× 11.2(D)	mm
Mass	1000 (Max)	g
Surface treatment	Anti-glare and hard-coating 3H (Haze value = 25)	

*1.Note: excluding back light cables, cover and pet sheet.

The thickness of module (D) doesn't contain the projection.

Outline dimensions are shown in Fig.1.

4. Input Terminals

4-1. TFT-LCD panel driving

CN1 (Interface signals and +3.3V DC power supply)

Using connectors : DF14H-20P-1.25H (Hirose Electric Co., Ltd.)

Corresponding connectors : DF14-20S-1.25C(Hirose Electric Co., Ltd.)

(※) Please do not use it besides corresponding connector.

Pin No.	Symbol	Function	Remark
1	Vcc	+3.3V Power supply	
2	Vcc	+3.3V Power supply	
3	GND		
4	GND		
5	RXIN0-	Receiver signal (-)	LVDS
6	RXIN0+	Receiver signal (+)	LVDS
7	GND		
8	RXIN1-	Receiver signal (-)	LVDS
9	RXIN1+	Receiver signal (+)	LVDS
10	GND		
11	RXIN2-	Receiver signal (-)	LVDS
12	RXIN2+	Receiver signal (+)	LVDS
13	GND		
14	RXCKIN-	Clock signal (-)	LVDS
15	RXCKIN+	Clock signal (+)	LVDS
16	GND		
17	RXIN3-	Receiver signal (-)	LVDS
18	RXIN3+	Receiver signal (+)	LVDS
19	HANTEN	Horizontal/Vertical display mode select signal	【note2】
20	LVDS_SET	LVDS_SET	【note1】

【note2】

H A N T E N = " L O W "



H A N T E N = " H i g h "



4-2. Data Mapping

1) 8 bit input

【note1】 pin assignment with LVDS_SET pin (Thine: THC63LVDF83A)

Transmitter		20pin LVDS_SET	
Pin No	Data	= H (3.3V)	= L (GND) Δ 1
51	TA0	R2	R0 (LSB)
52	TA1	R3	R1
54	TA2	R4	R2
55	TA3	R5	R3
56	TA4	R6	R4
3	TA5	R7 (MSB)	R5
4	TA6	G2	G0 (LSB)
6	TB0	G3	G1
7	TB1	G4	G2
11	TB2	G5	G3
12	TB3	G6	G4
14	TB4	G7 (MSB)	G5
15	TB5	B2	B0 (LSB)
19	TB6	B3	B1
20	TC0	B4	B2
22	TC1	B5	B3
23	TC2	B6	B4
24	TC3	B7 (MSB)	B5
27	TC4	High or low	High or low
28	TC5	High or low	High or low
30	TC6	DE	DE
50	TD0	R0 (LSB)	R6
2	TD1	R1	R7 (MSB)
8	TD2	G0 (LSB)	G6
10	TD3	G1	G7 (MSB)
16	TD4	B0 (LSB)	B6
18	TD5	B1	B7 (MSB)
25	TD6	(NA)	(NA)
31	CLK IN	CLK	CLK

<LVDS_SET=H>

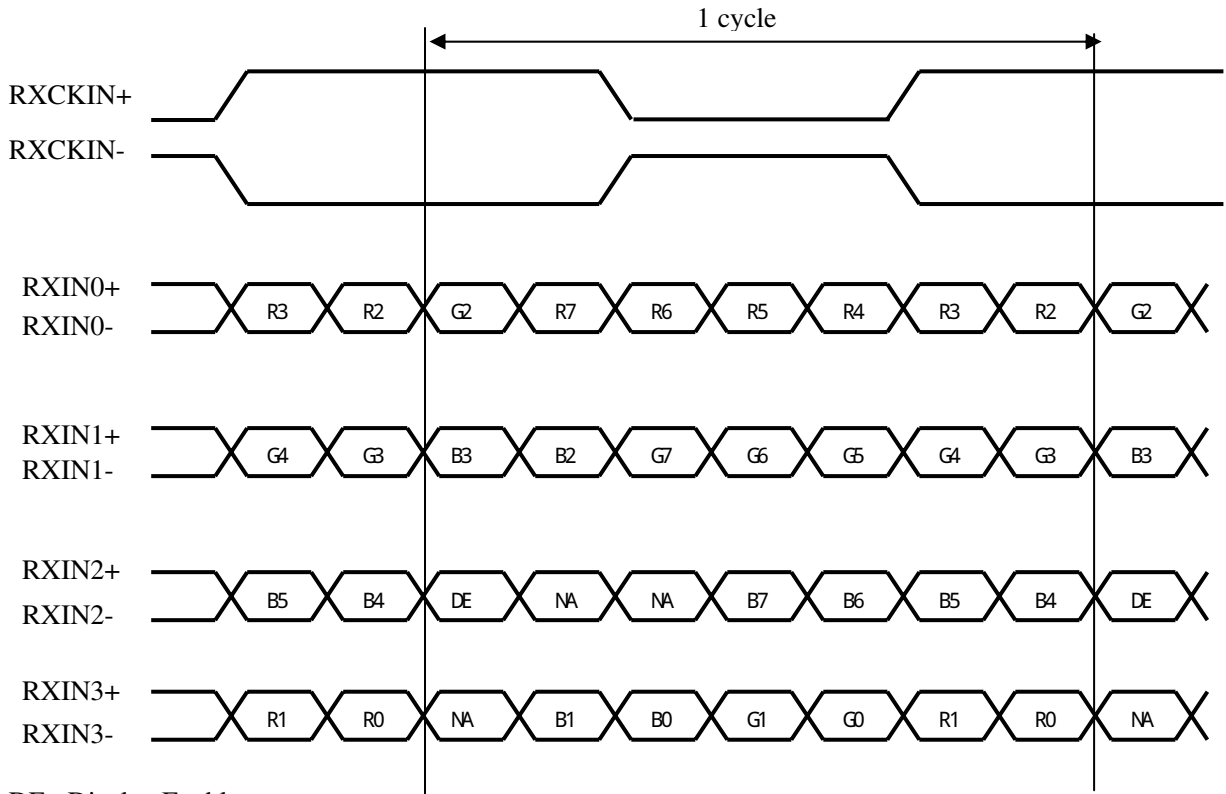

DE : Display Enable

NA : Not Available

<LVDS_SET = L > Δ 1

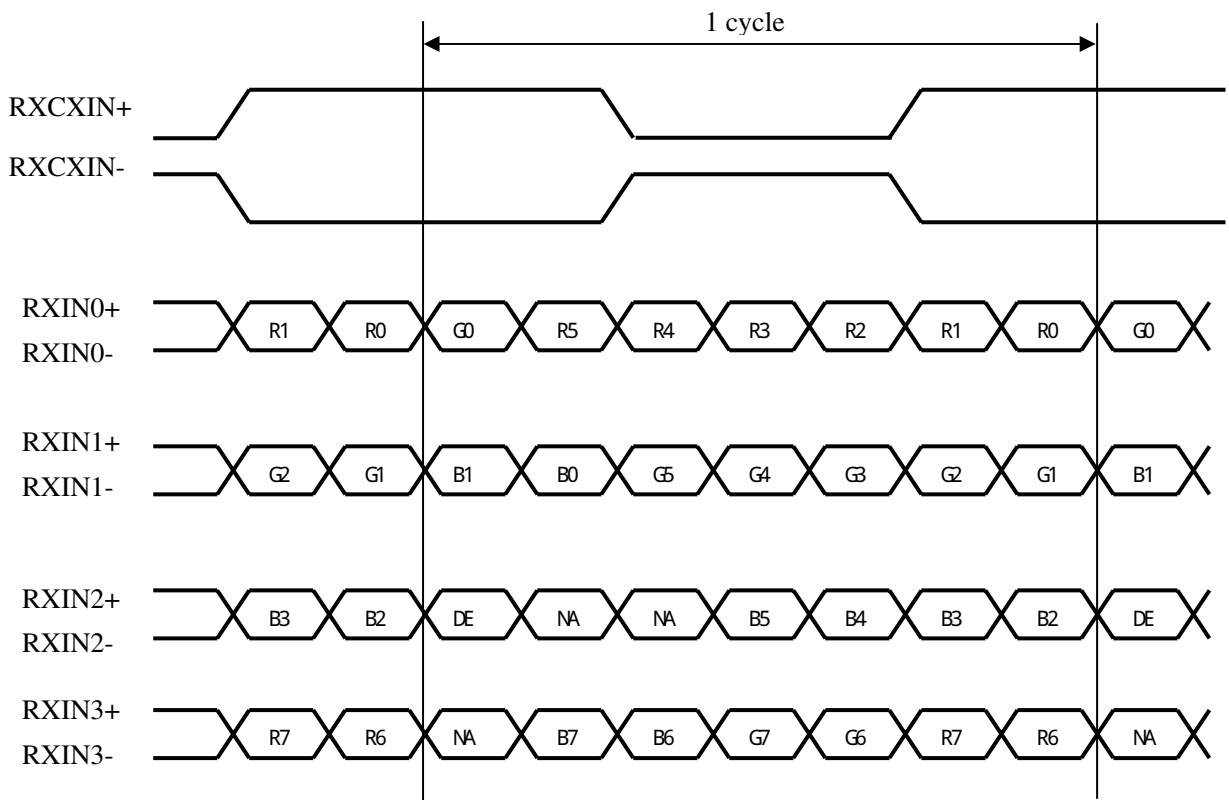

DE : Display Enable

NA : Not Available

2) 6 bit input

【note1】 pin assignment with LVDS_SET pin (Thine: THC63LVDF83A)

Transmitter		20pin LVDS_SET	
Pin No	Data	= H (3.3V)	= L (GND) Δ 1
51	TA0	R0 (LSB)	-
52	TA1	R1	-
54	TA2	R2	-
55	TA3	R3	-
56	TA4	R4	-
3	TA5	R5 (MSB)	-
4	TA6	G0 (LSB)	-
6	TB0	G1	-
7	TB1	G2	-
11	TB2	G3	-
12	TB3	G4	-
14	TB4	G5 (MSB)	-
15	TB5	B0 (LSB)	-
19	TB6	B1	-
20	TC0	B2	-
22	TC1	B3	-
23	TC2	B4	-
24	TC3	B5 (MSB)	-
27	TC4	High or low	-
28	TC5	High or low	-
30	TC6	DE	-
50	TD0	GND	-
2	TD1	GND	-
8	TD2	GND	-
10	TD3	GND	-
16	TD4	GND	-
18	TD5	GND	-
25	TD6	(NA)	-
31	CIKIN	CLK	-

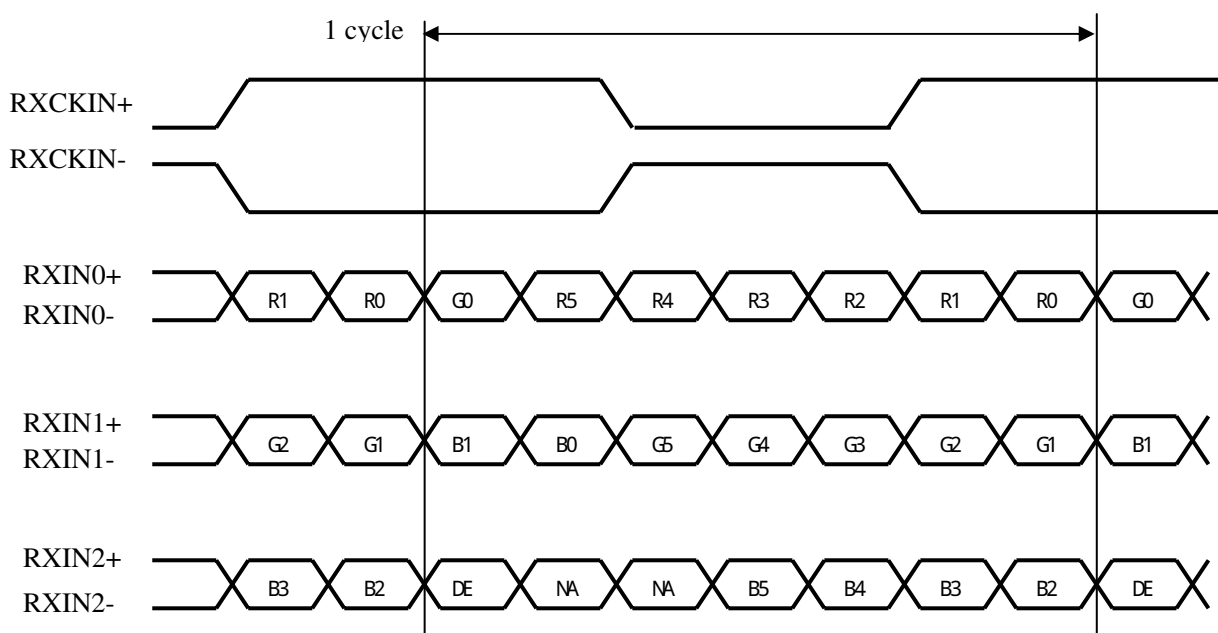

DE : Display Enable

NA : Not Available

(Computer Side)

(TFT-LCD side)

①8Bit Mode

LVDS_SET=L (20 pin=GND) Δ 1

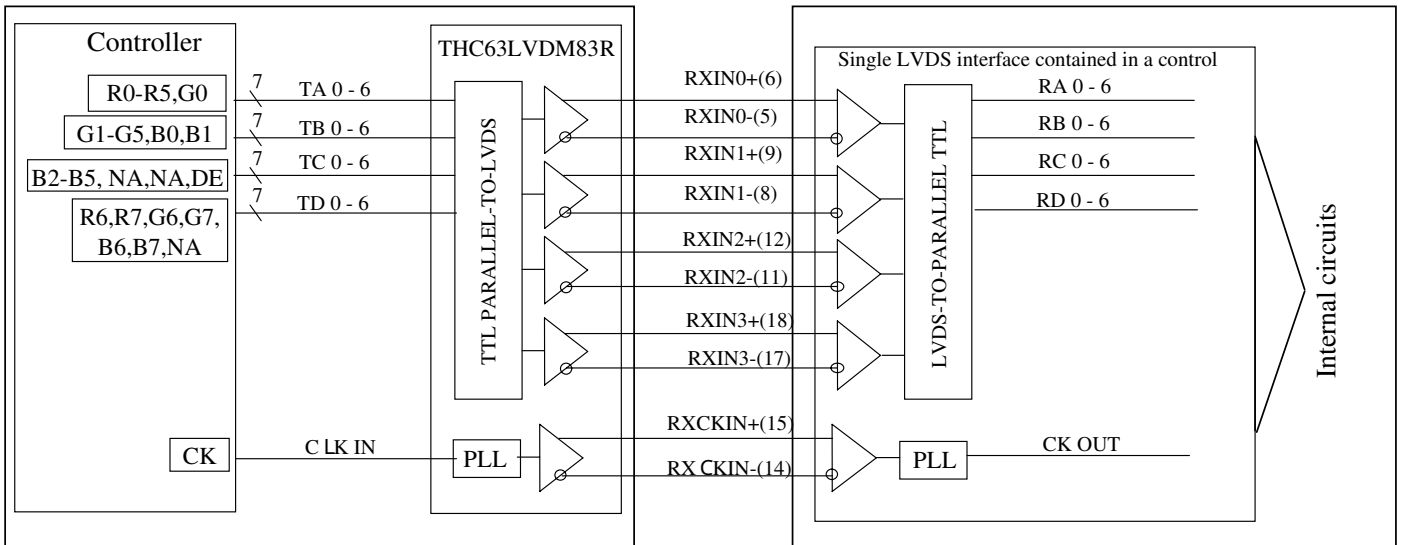

②8Bit Mode

LVDS_SET=H (20 pin=3.3[V])

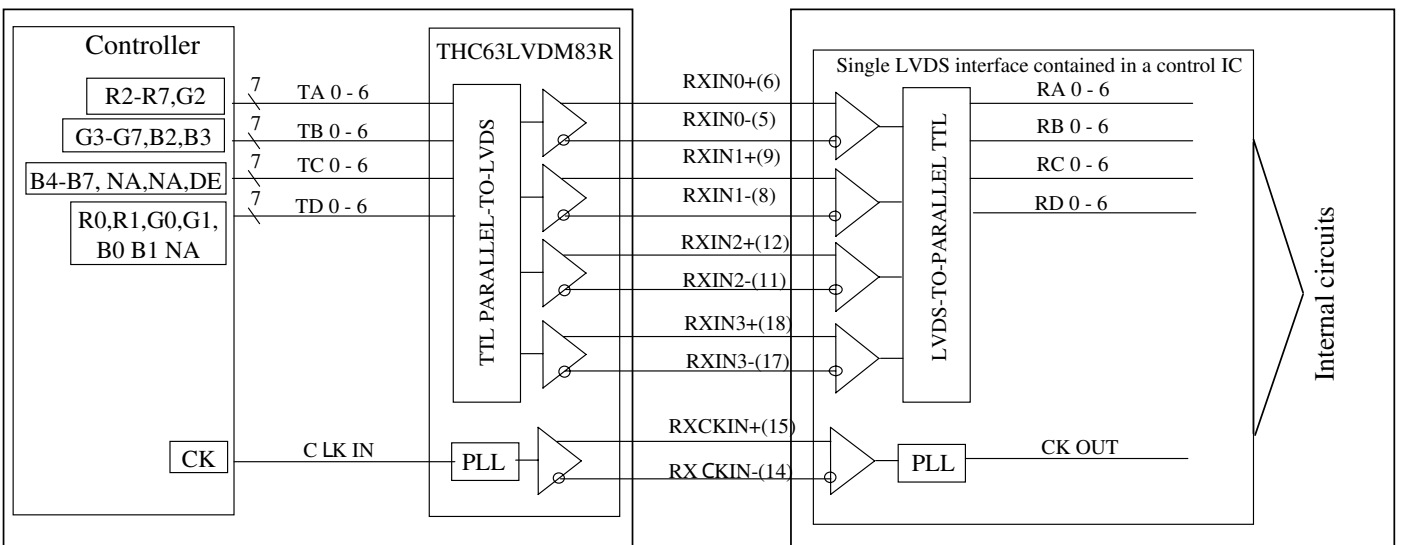

③6Bit Mode

LVDS_SET=H (20 pin=3.3[V])

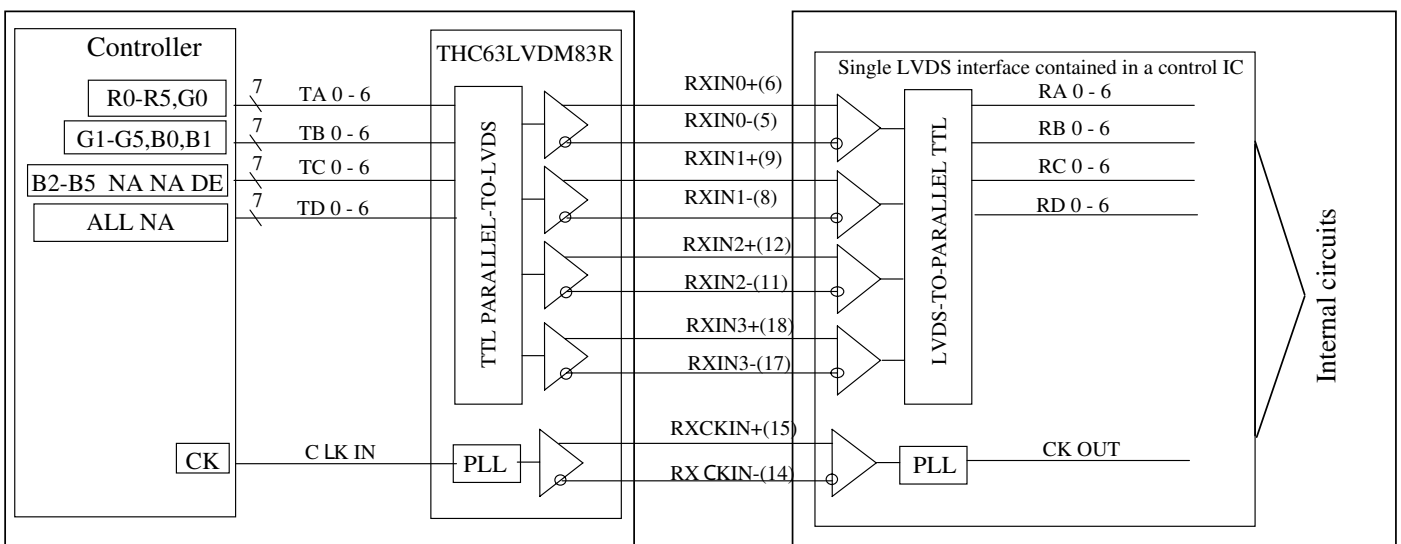

4-4. Backlight

CN 2, 3

The module-side connector : BHR-03VS-1 (JST)

The user-side connector : SM02(8.0)B-BHS-1-TB(LF)(SN) (JST)

Pin no.	symbol	I/O	Function	Color
1	V_{HIGH}	I	Power supply for lamp (High voltage side)	Pink
2	N.C.	-	-	
3	V_{LOW}	I	Power supply for lamp (Low voltage side)	White

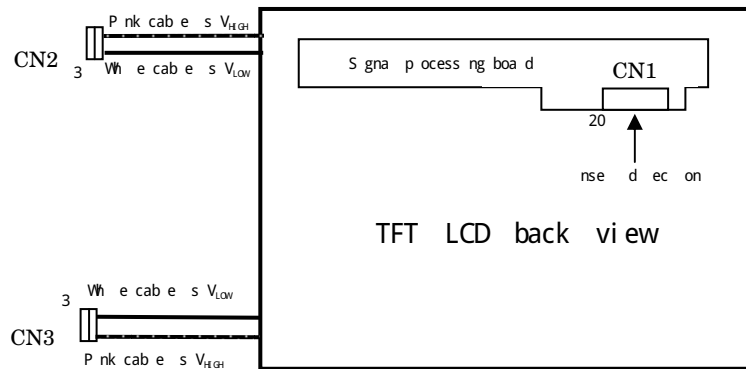
5. Absolute Maximum Ratings Δ 2

Parameter	Symbol	Condition	Ratings	Unit	Remark
Supply voltage	V_{CC}	$T_a=25^\circ\text{C}$	-0.3 ~ +4.0	V	
Input voltage	V_I	$T_a=25^\circ\text{C}$	-0.3 ~ $V_{CC} + 0.3$	V	
Storage temperature	T_{STG}	-	-25 ~ +60	$^\circ\text{C}$	【Note1】
Operating temperature	T_{OPA}	-	0 (Ambient) ~ +60 (Panel surface)	$^\circ\text{C}$	
Lamp Voltage	V_{La}	-	2000	V_{rms}	

【Note1】 Humidity : 95%RH Max. ($T_a \leq 40^\circ\text{C}$)

Maximum wet-bulb temperature at 39°C or less. ($T_a > 40^\circ\text{C}$)

No condensation.

6. Recommended operation condition

Parameter	Symbol	Min.	Typ.	Max.	Unit	Remark
Supply voltage	V_{CC}	+3.0	+3.3	+3.6	V	【Note1】
LVDS Signals	V_L	0		2.4	V	【Note2】
Input voltage	V_I	0		V_{CC}	V	【Note3】
Surface temperature	T_{opa}	0		+60	$^\circ\text{C}$	【Note4】

【Note1】 On-off conditions for supply voltage

- 0 < t1 ≤ 15ms
- 0 < t2 ≤ 10ms
- 0 < t3 ≤ 100ms
- 0 < t4 ≤ 1s
- 200ms < t5

Vcc-dip conditions Δ 2

- 1) 2.5V ≤ Vcc < 3.0V
td ≤ 10ms
- 2) Vcc < 2.5V

Vcc-dip conditions should also follow the On-off conditions for supply voltage

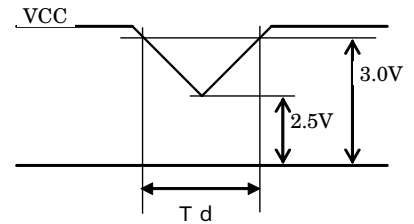
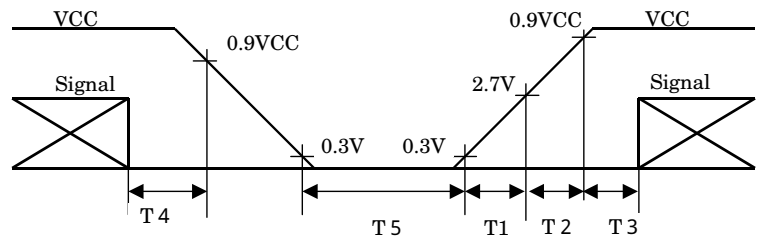

【Note2】 RXIN0-, RXIN0+,RXIN1-,RXIN1+,RXIN2-,RXIN2+,
RXCKIN-,RXCKIN+,RXIN3-,RXIN3+

【Note3】 LVDS_SET , HANTEN Δ 1

【Note4】 Humidity: 95%RH Max. at Ta=<40°C.

Maximum wet-bulb temperature at 39°C or less at Ta>40°C.

No condensation.

Maximum value : Panel surface temperature Δ 2

7. Electrical Characteristics

7-1. TFT-LCD panel driving Δ 1

Ta = 25°C

Parameter		Symbol	Min.	Typ.	Max.	Unit	Remark
Vcc	Supply voltage	Vcc	+3.0	+3.3	+3.6	V	-
	Current dissipation	Icc	-	300	400	mA	【Note2】
Permissive input ripple voltage		V _{RF}	-	-	100	mVp-p	Vcc=+3.3V
Differential input Threshold voltage	High	V _{TH}	-	-	+100	mV	V _{CM} =+1.2V 【Note1】
	Low	V _{TL}	-100	-	-	mV	
Input voltage width for LVDS receiver		V _i	0	-	2.4	V	-
Input voltage	High	V _{IH}	2.1	-	-	V	-
	Low	V _{IL}	-	-	0.6	V	
Terminal resistor		R _T	-	100	-	Ω	Differential input

【Note1】 V_{CM} : Common mode voltage of LVDS driver.

【Note2】 Typical current situation : 253-gray-bar pattern
Vcc=+3.3V, fck=65MHz, Ta=25°C
Gray scale : GS(n)

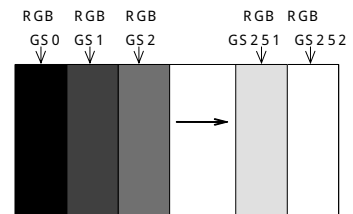

7-2. Backlight $\Delta 1, \Delta 2$

The back light system is an edge-lighting type with 2 CCFTs (Cold Cathode Fluorescent Tube).

The characteristics of the lamp are shown in the following table.

The value mentioned below is at the case of only CCFT.

Parameter	Symbol	Min.	Typ.	Max.	Unit	Remark
Lamp current range	I_L	3.5	6.5	7.5	mArms	【Note1】
Lamp voltage	V_L	-	660	-	Vrms	$I_L=6.5$ mArms $T_a=25^\circ\text{C}$ 55kHz
Lamp power consumption	P_L	-	4.3	-	W	【Note2】
Lamp frequency	F_L	40	55	70	kHz	【Note3】
Kick-off voltage	V_s	-	-	1,400	Vrms	Inverter output 【Note4】 $T_a=0^\circ\text{C}$
Lamp life time	T_L	50,000	-	-	hour	【Note5】

【Note1】 A lamp can be light in the range of lamp current shown above.

Maximum rating for current is measured by high frequency current measurement equipment connected to V_{LOW} at circuit showed below.

(Note : To keep enough kick-off voltage and necessary steady voltage for CCFT.)

Panel surface temperature : $0 \sim 60^\circ\text{C}$

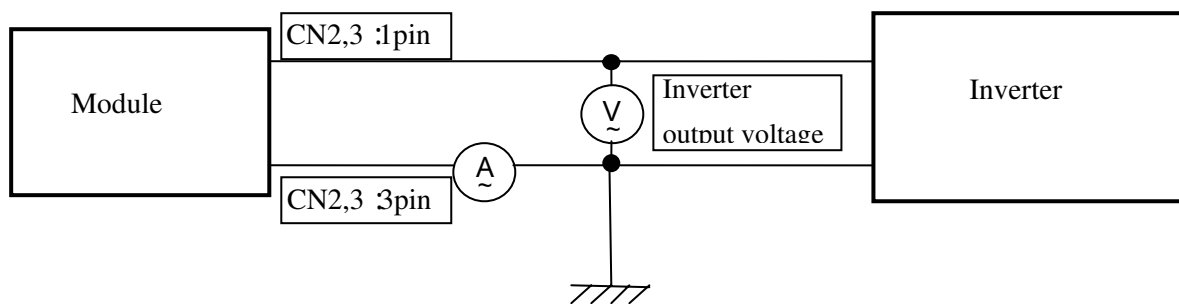

【Note2】 Referential data per one CCFT by calculation ($I_L \times V_L$).

The data don't include loss at inverter. ($I_L=6.5$ mArms)

【Note3】 Lamp frequency of inverter may produce interference with horizontal synchronous frequency, and this may cause horizontal beat on the display. Therefore, adjust lamp frequency, and keep inverter as far as from module or use electronic shielding between inverter and module to avoid interference.

【Note4】 The open output voltage of the inverter shall be maintained for more than 1s; otherwise the lamp may not be turned on.

【Note5】 Above value is applicable when lamp (the long side of LCD module) is placed horizontally. (Landscape position)

Lamp life time is defined that it applied either ① or ② under this condition (Continuous turning on at $T_a=25^\circ\text{C}$, $I_L=6.5$ mArms)

① Brightness becomes 50% of the original value under standard condition.

② Kick-off voltage at $T_a=0^\circ\text{C}$ exceeds maximum value, (1,400)Vrms.

(Lamp life time may vary if lamp is in portrait position due to the change of mercury density inside the lamp.)

Lamp life time shortens according to the used state and environment.

In case of operating under lower temp environment, the lamp exhaustion is accelerated and the brightness becomes lower.(Continuous operating for around 1 month under lower temp condition may reduce the brightness to half of the original brightness.)

The life of a lamp is accelerated when using it in the environment where a lamp cannot get warm easily.

(When using it outdoors and ON/OFF is repeated frequently)

In case of such usage under lower temp environment, periodical lamp check and exchange is recommended.

【Note6】 The performance of the backlight, for example life time or brightness, is much influenced by the characteristics of the DC-AC inverter for the lamp. When you design or order the inverter, please make sure that a poor lighting caused by the mismatch of the backlight and the inverter (miss-lighting, flicker, etc.) never occur. when you confirm it, the module should be operated in the same condition as it is installed in your instrument.

Be sure to use a back light power supply with the safety protection circuit such as the detection circuit for the excess voltage, excess current and or electric discharge waveform.

Be sure to use the detect circuit by which one side of the CCFT lamps can be controlled independently. Otherwise, when one side of the CCFT is open, the excess current may possibly be applied to the other side of the lamp.

【Note7】 It is required to have the inverter designed so that to allow the impedance deviation of the two CCFT lamps and the capacity deviation of barast capacitor.

【Note8】 Under the environment of 10 lx or less, miss-lighting delay may occur.

【Not e9】 A lamp waveform should satisfy the following conditions.

Wave efficiency : $1.20 \geq I_p(P) / I_{rms} \text{ or } I_p(N) / I_{rms} \leq 1.63$

Imbalanced value: $0.95 \leq I_p(P) / I_p(N) \leq 1.05$

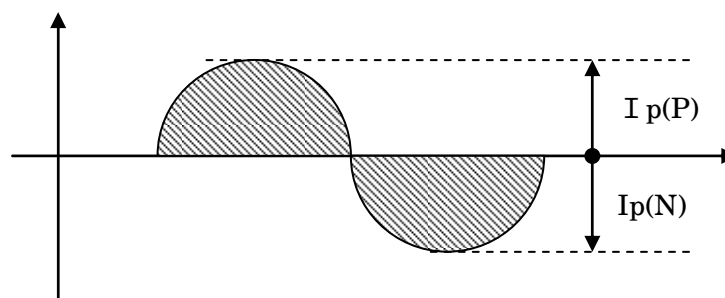

8. Timing characteristics of input signals

8-1. Timing characteristics

Parameter		Symbol	Min.	Typ.	Max.	Unit
Clock signal	Frequency	1/Tc	50.0	65.0	80.0	MHz
ENAB signal	Horizontal period	TH	1056	1344	1720	clock
			16.0	20.7	23.4	μs
	Horizontal period (High)	THd	1024	1024	1024	clock
	Vertical Frequency	fv	54	60	77	Hz
	Vertical period	TV	773	806	990	line
			12.98	16.66	18.51	ms
Vertical period (High)	TVd	768	768	768	line	

【Note】 In case of using the long vertical period, the deterioration of display quality, flicker etc. may occur.

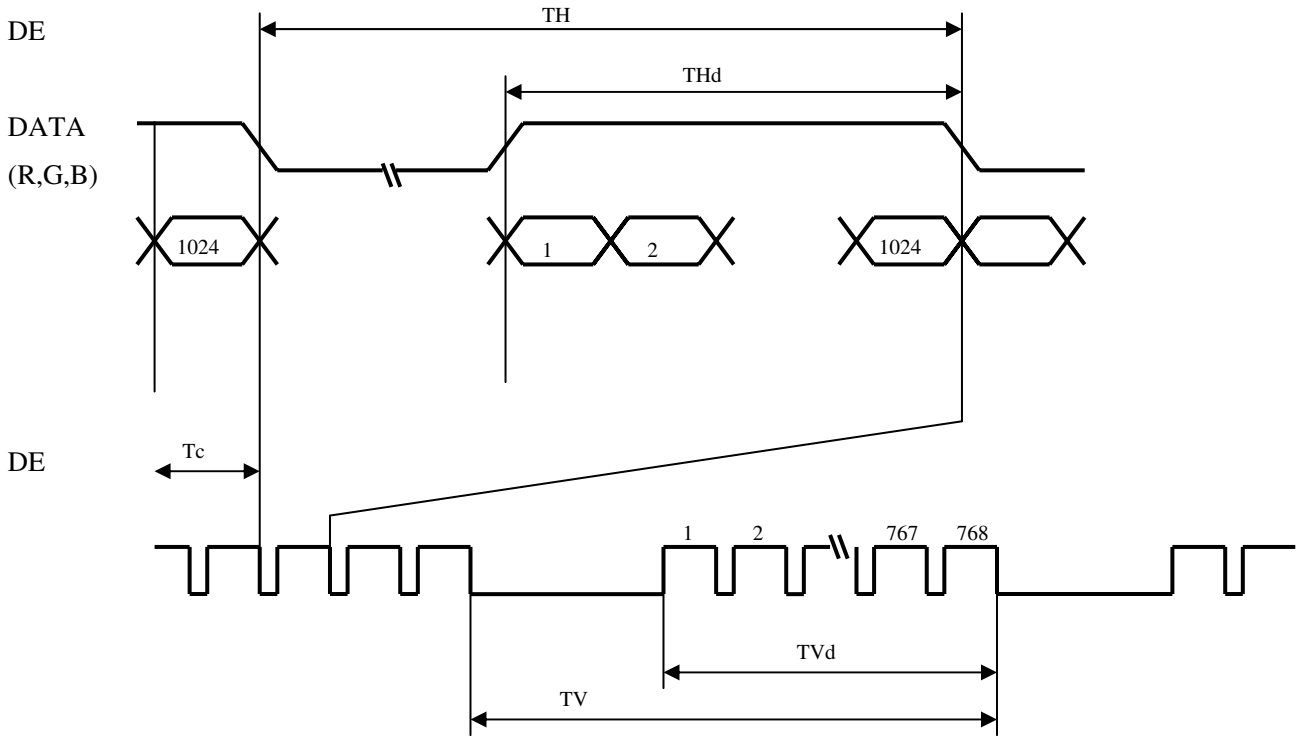

8-2. Input Data Signals and Display Position on the screen

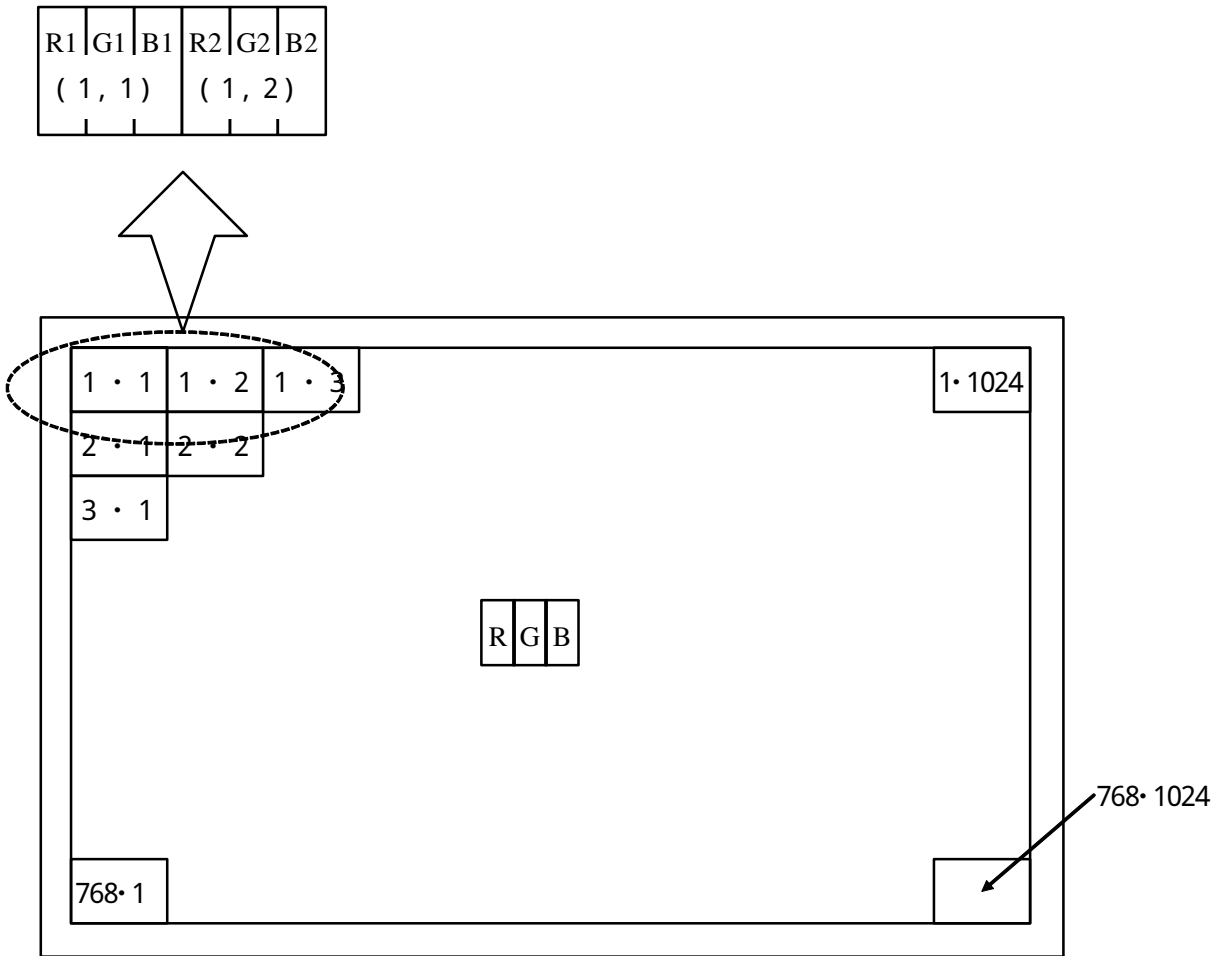

Display Position of Data (V, H)

9. Input Signals, Basic Display Colors and Gray Scale of Each Color

9-1. 8bit input $\Delta 2$

	Colors & Gray scale	Data signal																								
		Gray Scale	R0	R1	R2	R3	R4	R5	R6	R7	G0	G1	G2	G3	G4	G5	G6	G7	B0	B1	B2	B3	B4	B5	B6	B7
Basic Color	Black	-	0	0	0	0	0	0	0	0	0	0	0	0	0	0	0	0	0	0	0	0	0	0	0	0
	Blue	-	0	0	0	0	0	0	0	0	0	0	0	0	0	0	0	0	X	X	1	1	1	1	1	1
	Green	-	0	0	0	0	0	0	0	0	X	X	1	1	1	1	1	1	0	0	0	0	0	0	0	0
	Cyan	-	0	0	0	0	0	0	0	0	X	X	1	1	1	1	1	1	X	X	1	1	1	1	1	1
	Red	-	X	X	1	1	1	1	1	1	0	0	0	0	0	0	0	0	0	0	0	0	0	0	0	0
	Magenta	-	X	X	1	1	1	1	1	1	0	0	0	0	0	0	0	0	X	X	1	1	1	1	1	1
	Yellow	-	X	X	1	1	1	1	1	1	X	X	1	1	1	1	1	1	0	0	0	0	0	0	0	0
	White	-	X	X	1	1	1	1	1	1	X	X	1	1	1	1	1	1	X	X	1	1	1	1	1	1
Gray Scale of Red	Black	GS0	0	0	0	0	0	0	0	0	0	0	0	0	0	0	0	0	0	0	0	0	0	0	0	0
	↑	GS1	1	0	0	0	0	0	0	0	0	0	0	0	0	0	0	0	0	0	0	0	0	0	0	0
	Darker	GS2	0	1	0	0	0	0	0	0	0	0	0	0	0	0	0	0	0	0	0	0	0	0	0	0
	↑	↓					↓							↓								↓				
	↓	↓					↓							↓								↓				
	Brighter	GS250	0	1	0	1	1	1	1	1	0	0	0	0	0	0	0	0	0	0	0	0	0	0	0	0
	↓	GS251	1	1	0	1	1	1	1	1	0	0	0	0	0	0	0	0	0	0	0	0	0	0	0	0
	Red	GS252	X	X	1	1	1	1	1	1	0	0	0	0	0	0	0	0	0	0	0	0	0	0	0	0
Gray Scale of Green	Black	GS0	0	0	0	0	0	0	0	0	0	0	0	0	0	0	0	0	0	0	0	0	0	0	0	0
	↑	GS1	0	0	0	0	0	0	0	0	1	0	0	0	0	0	0	0	0	0	0	0	0	0	0	0
	Darker	GS2	0	0	0	0	0	0	0	0	0	1	0	0	0	0	0	0	0	0	0	0	0	0	0	0
	↑	↓					↓							↓								↓				
	↓	↓					↓							↓								↓				
	Brighter	GS250	0	0	0	0	0	0	0	0	0	1	0	1	1	1	1	1	0	0	0	0	0	0	0	0
	↓	GS251	0	0	0	0	0	0	0	0	1	1	0	1	1	1	1	1	0	0	0	0	0	0	0	0
	Green	GS252	0	0	0	0	0	0	0	0	X	X	1	1	1	1	1	1	0	0	0	0	0	0	0	0
Gray Scale of Blue	Black	GS0	0	0	0	0	0	0	0	0	0	0	0	0	0	0	0	0	0	0	0	0	0	0	0	0
	↑	GS1	0	0	0	0	0	0	0	0	0	0	0	0	0	0	0	0	1	0	0	0	0	0	0	0
	Darker	GS2	0	0	0	0	0	0	0	0	0	0	0	0	0	0	0	0	0	1	0	0	0	0	0	0
	↑	↓					↓							↓								↓				
	↓	↓					↓							↓								↓				
	Brighter	GS250	0	0	0	0	0	0	0	0	0	0	0	0	0	0	0	0	0	1	0	1	1	1	1	1
	↓	GS251	0	0	0	0	0	0	0	0	0	0	0	0	0	0	0	0	1	1	0	1	1	1	1	1
	Blue	GS252	0	0	0	0	0	0	0	0	0	0	0	0	0	0	0	0	X	X	1	1	1	1	1	1

0 : Low level voltage, 1 : High level voltage. X : Don't care

Each basic color can be displayed in 253 gray scales from 8 bit data signals. According to the combination of total 24 bit data signals, the 16-million-color display can be achieved on the screen.

9-2. 6bit input

	Colors & Gray scale	Data signal																		
		Gray Scale	R0	R1	R2	R3	R4	R5	G0	G1	G2	G3	G4	G5	B0	B1	B2	B3	B4	B5
Basic Color	Black	-	0	0	0	0	0	0	0	0	0	0	0	0	0	0	0	0	0	0
	Blue	-	0	0	0	0	0	0	0	0	0	0	0	0	1	1	1	1	1	1
	Green	-	0	0	0	0	0	0	1	1	1	1	1	1	0	0	0	0	0	0
	Cyan	-	0	0	0	0	0	0	1	1	1	1	1	1	1	1	1	1	1	1
	Red	-	1	1	1	1	1	1	0	0	0	0	0	0	0	0	0	0	0	0
	Magenta	-	1	1	1	1	1	1	0	0	0	0	0	0	1	1	1	1	1	1
	Yellow	-	1	1	1	1	1	1	1	1	1	1	1	1	0	0	0	0	0	0
	White	-	1	1	1	1	1	1	1	1	1	1	1	1	1	1	1	1	1	1
Gray Scale of Red	Black	GS0	0	0	0	0	0	0	0	0	0	0	0	0	0	0	0	0	0	0
	↑	GS1	1	0	0	0	0	0	0	0	0	0	0	0	0	0	0	0	0	0
	Darker	GS2	0	1	0	0	0	0	0	0	0	0	0	0	0	0	0	0	0	0
	↑	↓	↓					↓					↓							
	↓	↓	↓					↓					↓							
	Brighter	GS61	1	0	1	1	1	1	0	0	0	0	0	0	0	0	0	0	0	0
	↓	GS62	0	1	1	1	1	1	0	0	0	0	0	0	0	0	0	0	0	0
	Red	GS63	1	1	1	1	1	1	0	0	0	0	0	0	0	0	0	0	0	0
Gray Scale of Green	Black	GS0	0	0	0	0	0	0	0	0	0	0	0	0	0	0	0	0	0	0
	↑	GS1	0	0	0	0	0	0	1	0	0	0	0	0	0	0	0	0	0	0
	Darker	GS2	0	0	0	0	0	0	0	1	0	0	0	0	0	0	0	0	0	0
	↑	↓	↓					↓					↓							
	↓	↓	↓					↓					↓							
	Brighter	GS61	0	0	0	0	0	0	1	0	1	1	1	1	0	0	0	0	0	0
	↓	GS62	0	0	0	0	0	0	0	1	1	1	1	1	0	0	0	0	0	0
	Green	GS63	0	0	0	0	0	0	1	1	1	1	1	1	0	0	0	0	0	0
Gray Scale of Blue	Black	GS0	0	0	0	0	0	0	0	0	0	0	0	0	0	0	0	0	0	0
	↑	GS1	0	0	0	0	0	0	0	0	0	0	0	0	1	0	0	0	0	0
	Darker	GS2	0	0	0	0	0	0	0	0	0	0	0	0	0	1	0	0	0	0
	↑	↓	↓					↓					↓							
	↓	↓	↓					↓					↓							
	Brighter	GS61	0	0	0	0	0	0	0	0	0	0	0	0	1	0	1	1	1	1
	↓	GS62	0	0	0	0	0	0	0	0	0	0	0	0	0	1	1	1	1	1
	Blue	GS63	0	0	0	0	0	0	0	0	0	0	0	0	1	1	1	1	1	1

0 : Low level voltage, 1 : High level voltage.

Each basic color can be displayed in 64 gray scales from 6 bit data signals. According to the combination of total 18 bit data signals, the 262,144-color display can be achieved on the screen.

10. Optical Characteristics $\Delta 1, \Delta 2$

Ta=25°C, Vcc =+3.3V

Parameter		Symbol	Condition	Min.	Typ.	Max.	Unit	Remark
Viewing angle range	Vertical	θ_{11}	$CR \geq 10$	30	45	-	Deg.	【Note1,4】
		θ_{12}		45	55	-	Deg.	
	Horizontal	θ_{21}, θ_{22}		50	60	-	Deg.	
Contrast ratio		C R	$\theta = 0^\circ$	400	550	-		【Note2,4】
Response Time	Rise	τ_r	$\theta = 0^\circ$	-	2	-	ms	【Note3,4】
	Fall	τ_d		-	6	-	ms	
Chromaticity of White		x		0.283	0.313	0.343		【Note4】
		y		0.299	0.329	0.359		
Chromaticity of Red		x		0.567	0.597	0.627		
		y		0.297	0.327	0.357		
Chromaticity of Green		x		0.292	0.322	0.352		
		y		0.545	0.575	0.605		
Chromaticity of Blue		x		0.123	0.153	0.183		
		y		0.103	0.133	0.163		
Luminance of white		YL	200	250	-	cd/m ²	IL=6.5mA rms fL=55kHz 【Note4】	
White Uniformity		δ_w	-	-	1.43		【Note5】	

※ The measurement shall be executed 30 minutes after lighting at rating.

The optical characteristics shall be measured in a dark room or equivalent state with the method shown in Fig.2 below.

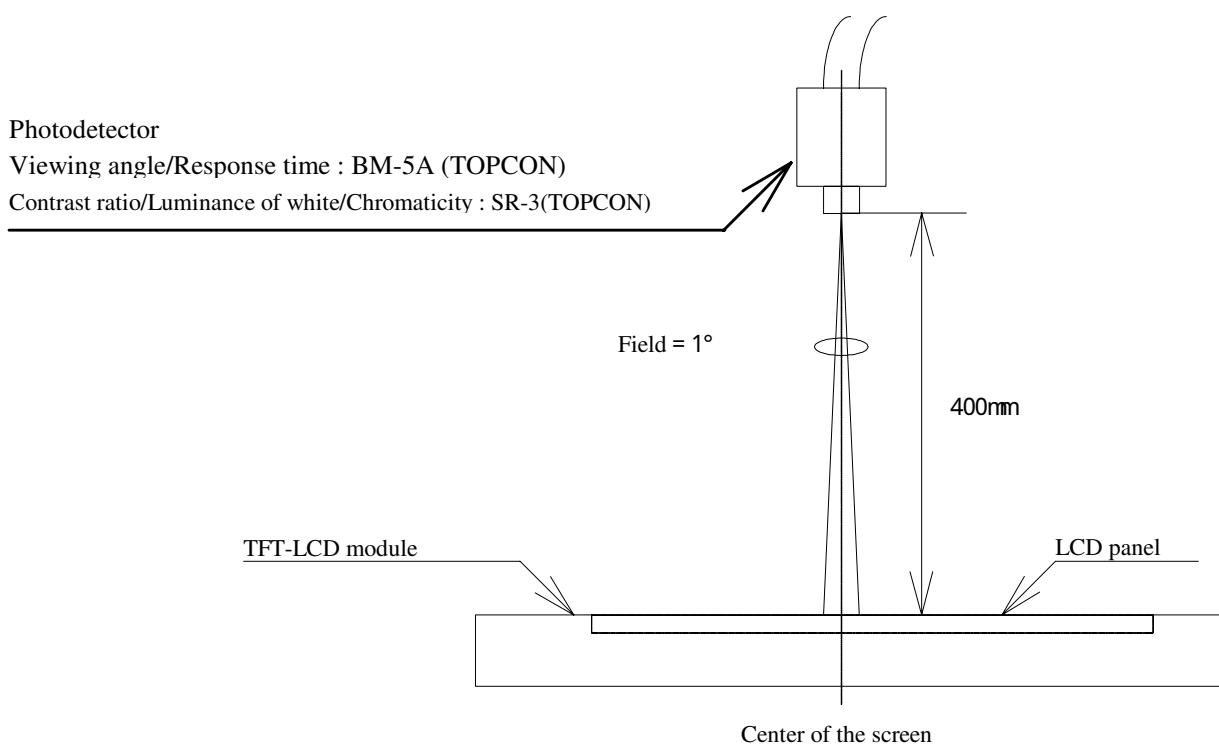
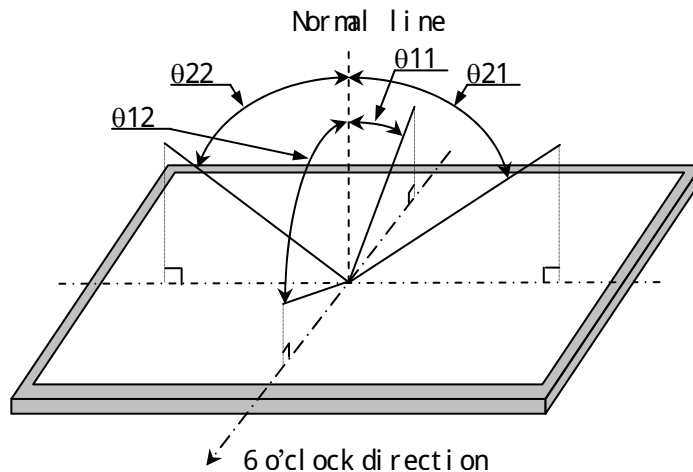

Fig.3 Optical characteristics measurement method

【Note1】 Definitions of viewing angle range:



【Note2】 Definition of contrast ratio:

The contrast ratio is defined as the following.

$$\text{Contrast Ratio (CR)} = \frac{\text{Luminance (brightness) with all pixels white}}{\text{Luminance (brightness) with all pixels black}}$$

【Note3】 Definition of response time:

The response time is defined as the following figure and shall be measured by switching the input signal for "black" and "white".

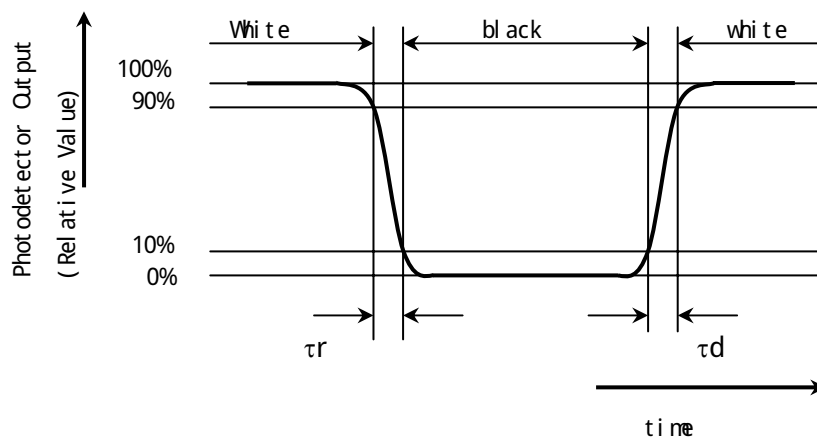

【Note4】 This shall be measured at center of the screen.

【Note5】 Definition of white uniformity:

White uniformity is defined as the following with nine measurements (① ~ ⑨).

$$\delta_w = \frac{\text{Maximum Luminance of nine points (brightness)}}{\text{Minimum Luminance of nine points (brightness)}}$$

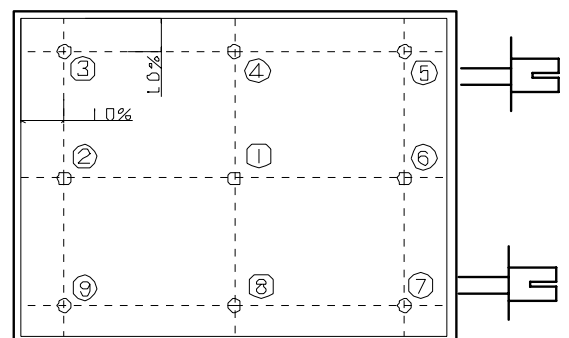

11. Handling Precautions

- a) Be sure to turn off the power supply when inserting or disconnecting the cable.
- b) Be sure to design the cabinet so that the module can be installed without any extra stress such as warp or twist.
- c) Since the front polarizer is easily damaged, pay attention not to scratch it.
Blow away dust on the polarizer with antistatic N₂ blow. It is undesirable to wipe off because a polarizer is sensitive.
It is recommended to peel off softly using the adhesive tape when soil or finger oil is stuck to the polarizer.
When unavoidable, wipe off carefully with a cloth for wiping lenses.
- d) Wipe off water drop immediately. Long contact with water may cause discoloration or spots.
- e) When the panel surface is soiled, wipe it with absorbent cotton or other soft cloth.
- f) Since the panel is made of glass, it may break or crack if dropped or bumped on hard surface.
Handle with care.
- g) Since CMOS LSI is used in this module, take care of static electricity and injure the human earth when handling. Observe all other precautionary requirements in handling components.
- h) Since there is a circuit board in the module back, stress is not added at the time of a design assembly.
Please make it like. If stress is added, there is a possibility that circuit parts may be damaged.
- i) Protection film is attached to the module surface to prevent it from being scratched .
Peel the film off slowly , just before the use, with strict attention to electrostatic charges.
Blow off 'dust' on the polarizer by using an ionized nitrogen.
- j) The polarizer surface on the panel is treated with Anti-Glare for low reflection. In case of attaching protective board over the LCD, be careful about the optical interface fringe etc. which degrades display quality.
- k) Do not expose the LCD panel to direct sunlight. Lightproof shade etc. should be attached when LCD panel is used under such environment
- l) Connect GND to 4 place of mounting holes to stabilize against EMI and external noise.
- m) There are high voltage portions on the backlight and very dangerous. Careless touch may lead to electrical shock. When exchange lamps or service, turn off the power without fail.
- n) When handling LCD modules and assembling them into cabinets, please be noted that long-term storage in the environment of oxidization or deoxidization gas and the use of such materials as reagent, solvent, adhesive, resin, etc. which generate these gasses, may cause corrosion and discoloration of the LCD modules.
- o) Cold cathode fluorescent lamp in LCD panel contains a small amount of mercury, please follow local ordinances or regulations for disposal.
- p) Be careful of a back light lead not to pull by force at the time of the wiring to an inverter, or line processing.
- q) When install LCD modules in the cabinet, please tighten with “torque=0.294± 0.02N· m(3.0± 0.2kgf· cm)”.
Be sure to confirm it in the same condition as it is installed in your instrument.
- r) Liquid crystal contained in the panel may leak if the LCD is broken. Rinse it as soon as possible if it gets inside your eye or mouth by mistake.
- s) Notice:Never dismantle the module , because it will cause failure.
Please don't remove the fixed tape, insulating tape etc that was pasted on the original module.
(except for protection film of the panel and the crepe tape(yellow tape) of fixing lamp cable temporarily.)

- t) Be careful when using it for long time with fixed pattern display as it may cause afterimage.
(Please use a screen saver etc., in order to avoid an afterimage.)
- u) Adjusting volume have been set optimally before shipment, so do not change any adjusted value.
If adjusted value is changed, the specification may not be satisfied.
- v) If a minute particle enters in the module and adheres to an optical material, it may cause display non-uniformity issue, etc. Therefore, fine-pitch filters have to be installed to cooling and inhalation hole if you intend to install a fan.
- w)The lamp used for this product is very sensitive to the temperature.
Luminance decreases rapidly when it is used for a long time or repeatedly under the environment of the low temperature or the module is being cooled.
Please avoid the continuous or repeating use of it under such an environment.
It may decrease up to 50% of the initial luminance in about one month under the low temperature environment.
Please consult our company when it is used under the environment like the above mentioned.
- x) In case of operating under lower temp environment, the lamp exhaustion is accelerated and the brightness becomes lower.(Continuous operating for around 1 month under lower temp condition may reduce the brightness to half of the original brightness.)
The life of a lamp is accelerated when using it in the environment where a lamp cannot get warm easily.
(When using it outdoors and ON/OFF is repeated frequently)
In case of such usage under lower temp environment, periodical lamp check and exchange is recommended.

12. Packing form

Product countries / Areas	JAPAN , TAIWAN, CHINA
Piling number of cartons	6
Package quantity in one carton	10pcs
Carton size(TYP)	434 x 395 x 338
Total mass of one carton filled with full modules	13Kg(TYP)
Packing form is shown	Fig.4

13 . Reliability test items

No	Test item	Conditions	
1	High temperature & high humidity operation test	Ta = 40°C ; 95%RH 240h (No condensation)	
2	High temperature operation test	Ta = 60°C (Panel surface) , 240h (The panel temp. must be less than 60°C)	
3	High temperature storage test	Ta = 60°C 240h	
4	Low temperature operation test	Ta = 0°C 240h	
5	Low temperature storage test	Ta = -25°C 240h	
6	Vibration test (non- operating)	Waveform : Sine wave Frequency : 10 ~ 57Hz/Vibration width (one side) : 0.075mm : 57 ~ 500Hz/Gravity : 9.8m/s ² Sweep time : 11minutes Test period : 3 hours (1 hour for each direction of X,Y,Z)	【Note】
7	Shock test (non- operating)	Max. gravity : 490m/s ² Pulse width : 11ms, half-sine wave Direction : ± X, ± Y, ± Z, once for each direction.	
8	Thermal shock test (Storage)	Ta=-25°C ~ 60°C ; 5 cycles Test period : 10 hours (1 hour for each temperature)	【Note】
9	Altitude	Ta=50°C,70kPa,3,048m(10,000ft), t=24h (Operating) Ta=70°C,12kPa,15,240m(50,000ft), t=24h (Storage)	

【Note】

A gap of panel shall not occur by vibration or the shock.

【Result Evaluation Criteria】

Under the display quality test conditions with normal operation state, these shall be no change which may affect practical display function. (normal operation state : Temperature:15 ~ 35°C, Humidity:45 ~ 75%, Atmospheric pressure:86 ~ 106kpa)

14. Others

14-1. Lot No. Label: △ 1

The diagram shows a SHARP product label with the following text: "LQ150X1LG45", "SHARP", "MADE IN ○○○○○", and "One or more of U.S. patents 5489989, 5953784, 6017452 and 6433851". Annotations point to "LQ150X1LG45" as the Model number and "MADE IN ○○○○○" as the Lot Number. A table below the label lists product countries and areas.

Product countries / Areas	
Japan	MADE IN JAPAN
Taiwan	MADE IN TAIWAN
China	MADE IN CHINA

Below the table, a Lot Number is shown as a sequence of digits in circles: (7) (3) (0) (0) (*). Below this, a Serial No. (5 digits) is shown as (0) (0) (0) (0) (1). The asterisk (*) is identified as the Discernment code. The first four digits (7, 3, 0, 0) are identified as the Production month (1-9X, Y, Z). The last digit (1) is identified as the Production year (Last digit of dominical year).

14-2. Packing box Label:

The diagram shows a packing box label with the following text: "社内品番 (4S) LQ150X1LG45", "Barcode", "LotNO (1T) 2007.xx.xx", "Barcode", "Quantity (Q) xx pcs", "ユーザ品番", and "シャープ物流用ラベルです。". Annotations point to "社内品番 (4S) LQ150X1LG45" as the Model number, "LotNO (1T) 2007.xx.xx" as the Lot number (DATE), and "Quantity (Q) xx pcs" as the Quantity of module.

Internal Use Only
R. C.

※ R.C. (RoHS Compliance) means these parts have corresponded with the RoHS directive.

14-3. If any problem occurs in relation to the description of this specification , it shall be resolved through discussion with spirit of cooperation.

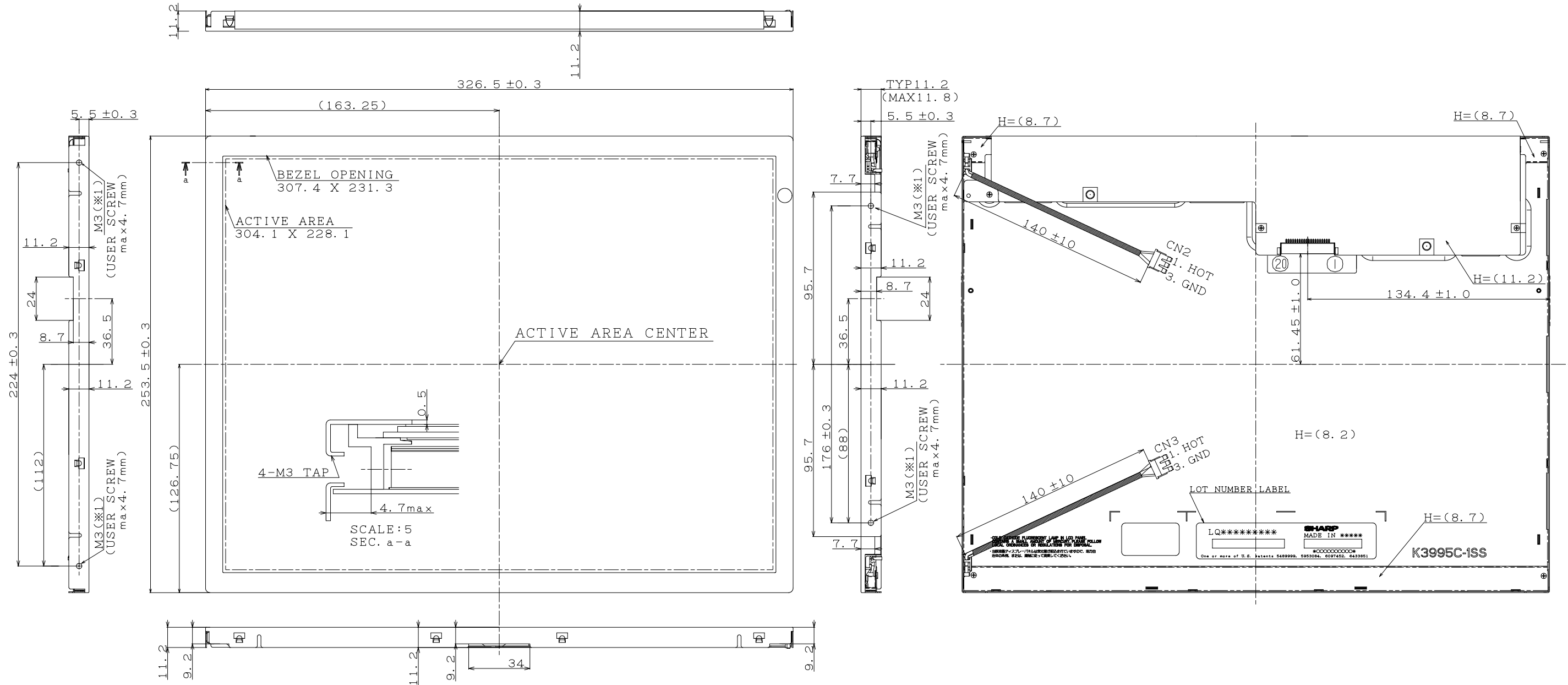

I/F CONNECTOR

CN1:DF14H-20P-1.25H(HIROSE)

① Vcc	⑥ RXIN0+	④ RXIN2-	⑩ GND
② Vcc	⑦ GND	③ RXIN2+	⑦ RXIN3-
③ GND	⑧ RXIN1-	② GND	⑥ RXIN3+
④ GND	⑨ RXIN1+	① RXCKIN-	⑨ HANTEN
⑤ RXIN0-	⑩ GND	⑤ RXCKIN+	② LVDS_SET

CN2, CN3:BHR-03VS-1

1	V HIGH
2	NC
3	V LOW

BEZEL /DISPLAY POSITION

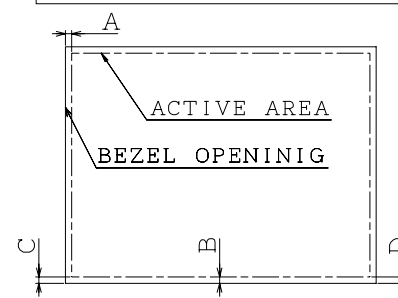

NOTES

- 1) UNSPECIFIED TOLERANCE TO BE ±0.2
- 2) WARP AND FLOATING FOR PRINTED WIRING BOARD AND CHASSIS ARE EXCLUDED FROM THE THICKNESS OF THE UNIT
- (*) TIGHTEN TORQUE (RECOMMENDATION)
0.294N·m±0.02N·m
(3.0kgf·cm±0.2kgf·cm)

- 1) TOLERANCE X-DIRECTION A: 1.65±0.8
- 2) TOLERANCE Y-DIRECTION B: 1.6±0.8
- 3) OBLIQUITY OF DISPLAY AREA IC-DI<0.8

Fig. 1 LQ150X1LG45 OUTLINE DIMENSIONS

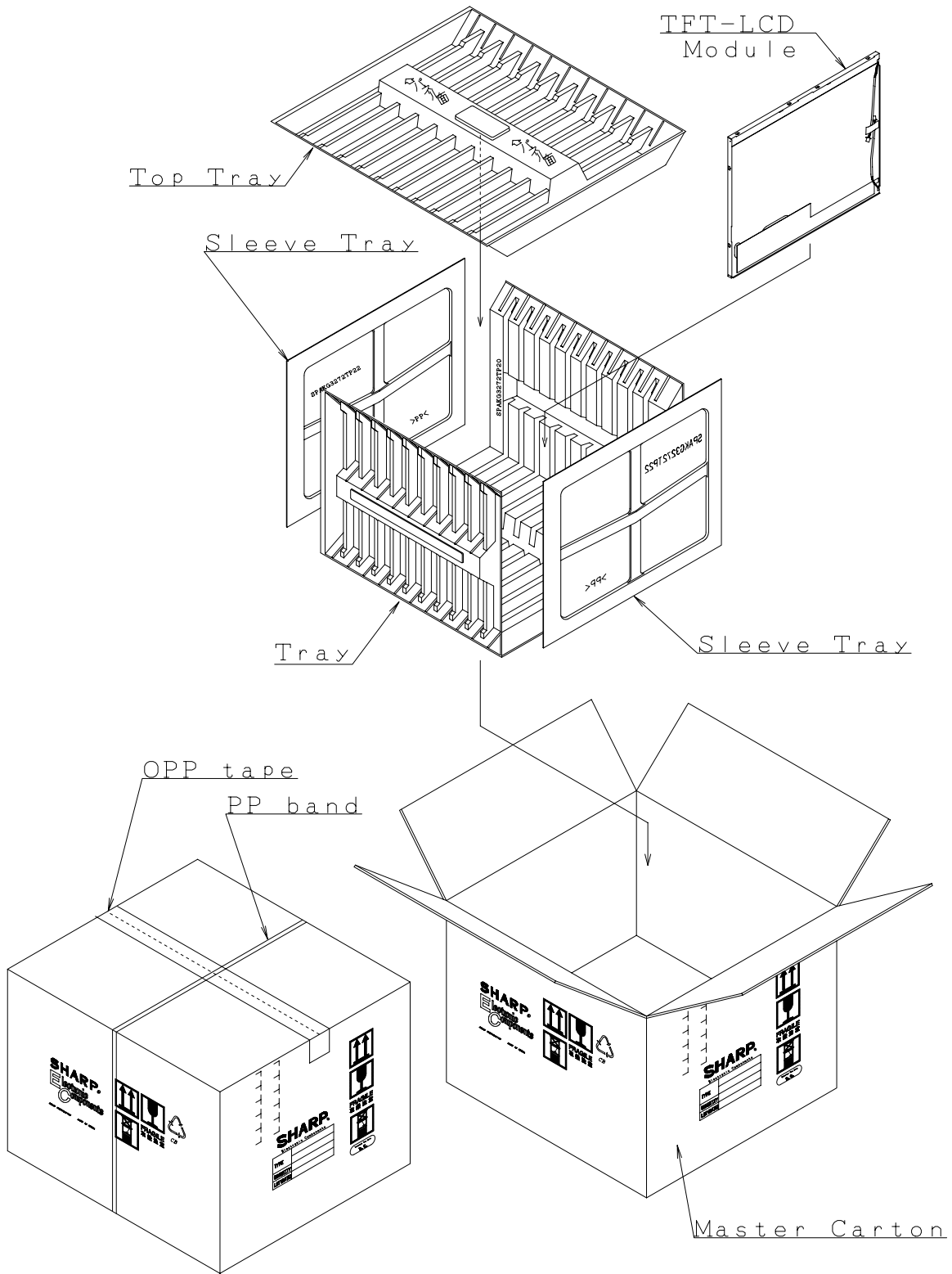

Fig4. Packing Form