

# LCD Specification

LCD Group

LQ150X1LG75XA TFT LCD

**Product Specification**

September 2009

# CONTENTS

No.	Item	Page
--	COVER	1
--	CONTENTS	2
1	APPLICATION	3
2	OVERVIEW	4
3	ABSOLUTE MAXIMUM RATINGS	5
4	ELECTRICAL CHARACTERISTICS	5, 6, 7
5	INTERFACE PIN CONNECTION	8, 9
6	INTERFACE TIMING	10, 11, 12, 13, 14
7	BLOCK DIAGRAM	15
8	MECHANICAL SPECIFICATION	16, 17
9	OPTICAL CHARACTERISTICS	18, 19, 20
10	RELIABILITY TEST CONDITION	21
11	OTHER FEATURE	22
12	HANDLING PRECAUTIONS FOR TFT-LCD MODULE	23, 24, 25

## 2. OVERVIEW

LQ150X1LG75XA is 15.0" color TFT-LCD (Thin Film Transistor Liquid Crystal Display) module composed of LCD panel, driver ICs, control circuit, LED driver and backlight unit.

By applying 6 bit or 8 bit digital data, 1024 × 768, 262k-color or 16.7M-color images are displayed on the 15.0" diagonal screen. Input power voltages are 3.3 V for LCD driving and 12.0 V for backlight unit.

The type of data and control signals are digital and transmitted via LVDS interface per Typ. 65 MHz clock cycle.

General specifications are summarized in the following table:

ITEM	SPECIFICATION
Display Area (mm)	304.1(H) × 228.1(V) (15.0-inch diagonal)
Number of Dots	1024 × 3 (H) × 768 (V)
Pixel Pitch (mm)	0.297 (H) × 0.297 (V)
Color Pixel Arrangement	RGB vertical stripe
Display Mode	Normally white
Number of Color	262k(6 bit/color), 16.7M(8 bit/color)
Luminance (cd/m <sup>2</sup> )	380
Viewing Angle (CR ≥ 10)	-80~80°(H), -70~70°(V)
Surface Treatment	Anti-glare and hard-coating 3H
Electrical Interface	LVDS (6 bit/8 bit)
Viewing direction	Higher Contrast ratio: 6 o'clock Less gray scale reversal: 12 o'clock
Module Size (mm)	326.5 (W) × 253.5 (H) × 12.0(D)
Module Mass (g)	1100
Backlight Unit	LED, Edge-light, Unreplaceable

Characteristic value without any note is typical value.

### 3. ABSOLUTE MAXIMUM RATINGS

ITEM	SYMBOL	MIN.	MAX.	UNIT
Power Supply Voltage for LCD	VCC	0	4.0	V
Logic Input Voltage	VI	-0.3	VCC+0.3	V
Backlight Power Supply Input Voltage	VL	-0.3	14.0	V
Backlight ON-OFF	BLEN	-0.3	VL	V
Light Dimming Control (PWM) input voltage	V <sub>PDIM</sub>	-0.3	5.8	V
Operation Temperature (Panel) <small>Note 1,2)</small>	T <sub>op(Panel)</sub>	0	65	°C
Operation Temperature (Ambient) <small>Note 2)</small>	T <sub>op(Ambient)</sub>	0	65	°C
Storage Temperature <small>Note 2)</small>	T <sub>stg</sub>	-20	65	°C

[Note]

- 1) The relative temperature and humidity range are 90%RHMax. (Ta ≤ 40°C).
- 2) The maximum wet bulb temperature ≤ 39°C (Ta > 40°C) and without dewing.
- 3) If you use the product in a environment which over the definition of temperature and humidity too long to effect the result of eye-aching.
- 4) If you operate the product in normal temperature range, the center surface of panel should be under 65°C.

### 4. ELECTRICAL CHARACTERISTICS

(1) TFT-LCD

Ambient temperature: Ta = 25°C

ITEM	SYMBOL	MIN.	TYP.	MAX.	UNIT	Remarks	
Power Supply Voltages for LCD	VCC	3.0	3.3	3.6	V	*1)	
Power Supply Currents for LCD	ICC	--	480	800	mA	*2)	
Permissive Input Ripple Voltage	VRP	--	--	100	mVp-p	VCC = +3.3V	
Logic Input Voltage	High	VIH	0.8×VCC	--	VCC	V	MODE
	Low	VIL	0	--	0.2×VCC	V	MODE

\*1) Power and signals sequence:

$$\begin{aligned}
 0.5 \leq t1 \leq 10 \text{ ms} & & 200 \text{ ms} \leq t4 \\
 0 < t2 \leq 50 \text{ ms} & & 200 \text{ ms} \leq t5 \\
 0 < t3 \leq 50 \text{ ms} & & 0 \text{ ms} \leq t6
 \end{aligned}$$

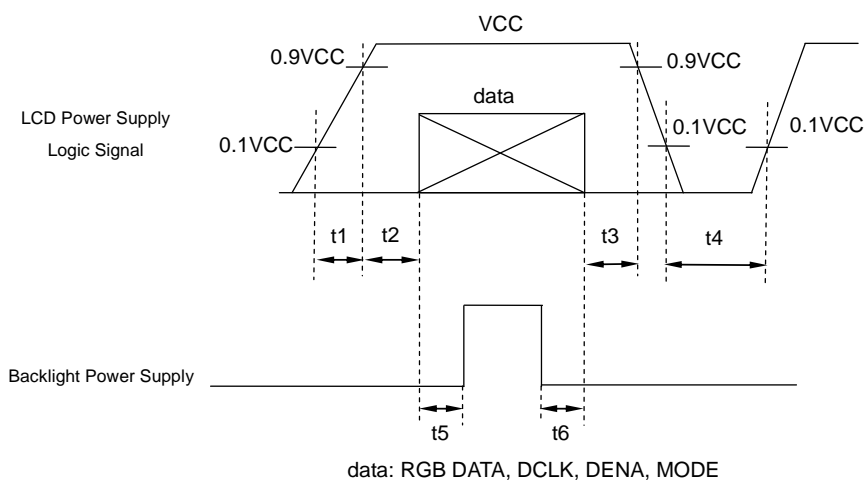

VCC-dip conditions:

- 1) When  $2.7\text{ V} \leq VCC < 3.0\text{ V}$ ,  $t_d \leq 10\text{ ms}$
- 2) When  $VCC < 2.7\text{ V}$

VCC-dip conditions should also follow the power and signals sequence.

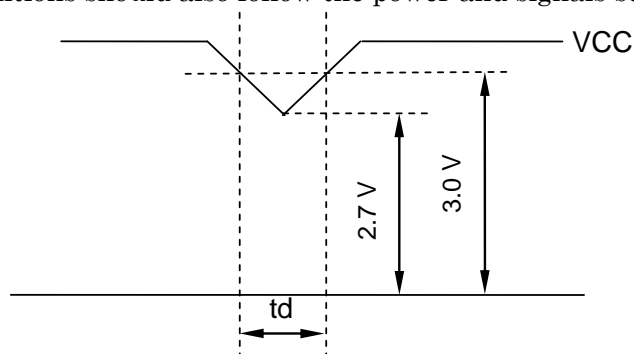

\*2)  $VCC = +3.3\text{ V}$ ,  $f_H=48.36\text{ kHz}$ ,  $f_V=60\text{ Hz}$ ,  $f_{CLK}=65\text{ MHz}$

Display image at typical power supply current value is 256-gray-bar pattern (8 bit), 768 line mode.

\*3) Fuse

Parameter	Fuse Type Name	Supplier	Remark
VCC	F0603FA3000V032T	AEM	*)

\*) The power supply capacity should be designed to be more than the fusing current.

(2) Backlight

$T_a=25^\circ\text{C}$

ITEM	SYMBOL	MIN.	TYP.	MAX.	UNIT	Remarks	
Power Supply Input Voltage	VL	10.8	12.0	13.2	V	*1)	
Power Supply Input Current	IL	600	700	850	mA	*3)	
Power Supply Input Current	PL	--	8.4	9.2	W	Dimming=100%, VL=12.0V	
Backlight ON-OFF	High	BLEN	2.5	--	VL	V	ON
	Low		0	--	0.4	V	OFF
Light Dimming Control (PWM) input voltage	High	$V_{PDIM}$	1.8	--	5.0	V	ON
	Low		0	--	0.8	V	OFF
PWM frequency	$f_{PDIM}$	100	400	500	Hz	*2)	
Pulse width of PDIM	$t_{PDIM}$	100	--	DC	us	*2)	
LED Life Time	LT	80,000	100,000	--	h	*4), *5)	

\*1) Power and signals sequence:

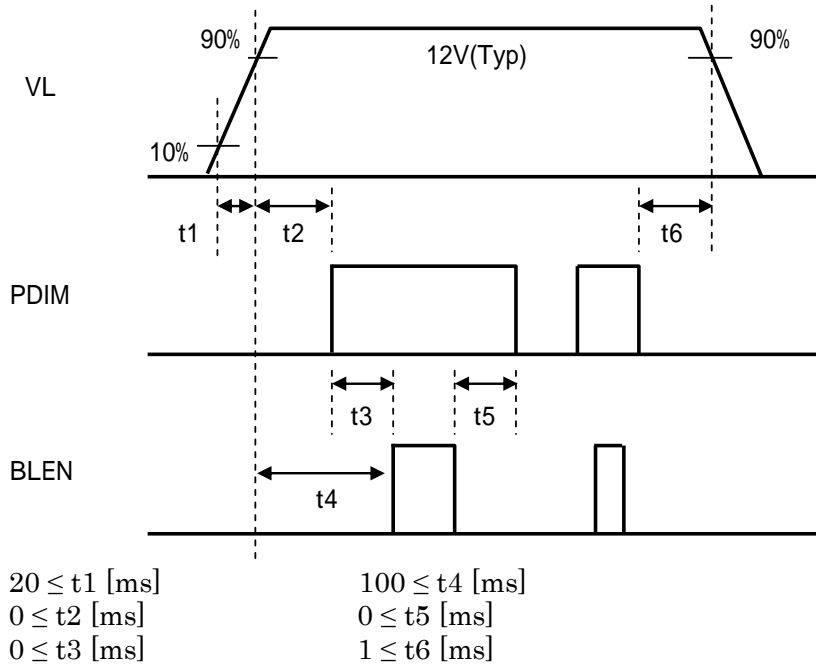

VL-dip conditions:

- 1) When  $9.72\text{ V} \leq VL < 10.8\text{ V}$ ,  $t_d \leq 10\text{ ms}$
- 2) When  $VL < 9.72\text{ V}$

VL-dip conditions should also follow the power and signals sequence.

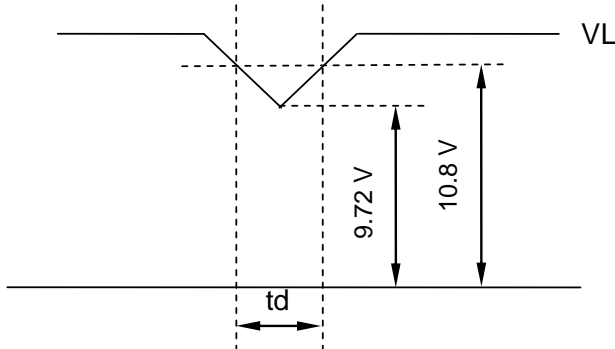

\*2) Lower frequency causes the flicker or the image breaking of motion picture.

Depending on the PDIM signal integrity (jitter etc.), the flicker may be visible. Please evaluate in advance.

The dimming ratio (D) can be calculated by following equation:

$$D = f_{PDIM} \times t_{PDIM}. \text{ Therefore, the minimum dimming ratio is } f_{PDIM} \times t_{PDIM(\min)}$$

\*3) Fuse

Parameter	Fuse Type Name	Supplier	Remark
VL	F0603HI2000V032T	AEM	*)

\*) The power supply capacity should be designed to be more than the fusing current.

\*4) LED life time is defined as the time when the brightness becomes 50% of the initial value.

\*5) The life time of the backlight depends on the ambient temperature. The life time will decrease under high temperature.

## 5. INTERFACE PIN CONNECTION

### (1) CN 1(Interface Signal)

Used connector: MSB240420HD (STM) or DF14H-20P-1.25(56) (HIROSE)

Corresponding connector: P240420 (STM) or DF14-20S-1.25C (HIROSE)

Pin No.	Symbol	Function (ISP 6 bit compatibility mode)		Function (ISP 8 bit compatibility mode)
		6 bit input	8 bit input	
1	VCC	+3.3 V Power supply		←
2	VCC	+3.3 V Power supply		←
3	GND	GND		←
4	GND	GND		←
5	Link 0-	R0, R1, R2, R3, R4, R5, G0	R2, R3, R4, R5, R6, R7, G2	R0, R1, R2, R3, R4, R5, G0
6	Link 0+	R0, R1, R2, R3, R4, R5, G0	R2, R3, R4, R5, R6, R7, G2	R0, R1, R2, R3, R4, R5, G0
7	GND	GND		←
8	Link 1-	G1, G2, G3, G4, G5, B0, B1	G3, G4, G5, G6, G7, B2, B3	G1, G2, G3, G4, G5, B0, B1
9	Link 1+	G1, G2, G3, G4, G5, B0, B1	G3, G4, G5, G6, G7, B2, B3	G1, G2, G3, G4, G5, B0, B1
10	GND	GND		←
11	Link 2-	B2, B3, B4, B5, DENA	B4, B5, B6, B7, DENA	B2, B3, B4, B5, DENA
12	Link 2+	B2, B3, B4, B5, DENA	B4, B5, B6, B7, DENA	B2, B3, B4, B5, DENA
13	GND	GND		←
14	CLKIN-	Clock -		←
15	CLKIN+	Clock +		←
16	GND	GND		←
17	Link3-	See: *2)	R0, R1, G0, G1, B0, B1	R6, R7, G6, G7, B6, B7
18	Link3+	See: *2)	R0, R1, G0, G1, B0, B1	R6, R7, G6, G7, B6, B7
19	MODE	Low=ISP 6 bit compatibility mode		High=ISP 8 bit compatibility mode
20	GND	GND		

\*1) Metal frame is connected to signal GND.

\*2) Recommended wiring of Pin 17,18 (6 bit input)

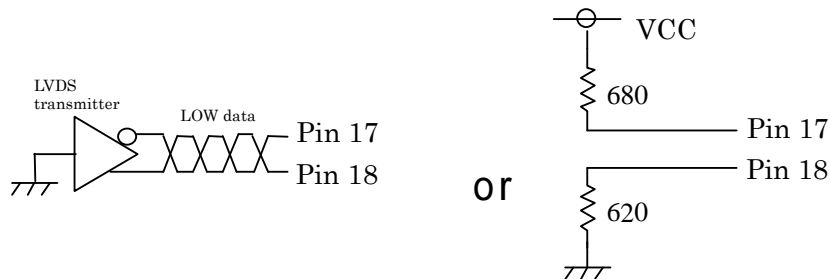

### (2) CN 2(Backlight)

Backlight-side connector: CR03-P06H2B-2 (CONNTEK)

Corresponding connector: CR03-S06C3 (CONNTEK), FI-S6S (JAE)

Pin No.: The left side pin is No.1.

Pin No.	Symbol	Function
1	VL	Power Supply Input Voltage
2	VL	Power Supply Input Voltage
3	GND	GND
4	GND	GND
5	BLEN	Backlight ON-OFF (High: ON, Low: OFF)
6	V <sub>PDIM</sub>	Light Dimming Control (PWM) Input Voltage (High active)

\*1) BLEN is NOT designed for dimming.

### (3) ISP data mapping

#### a. ISP 6 bit compatibility mode(6 bit input)

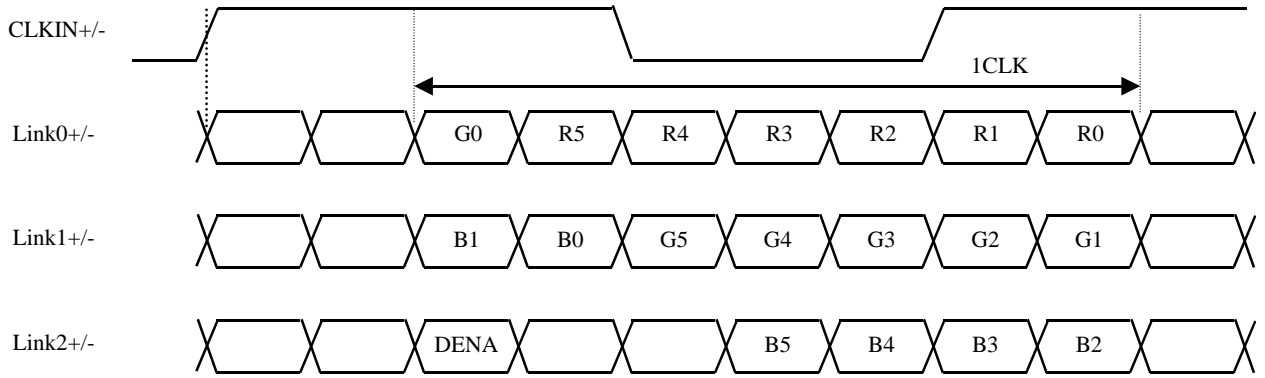

#### b. ISP 6 bit compatibility mode(8 bit input)

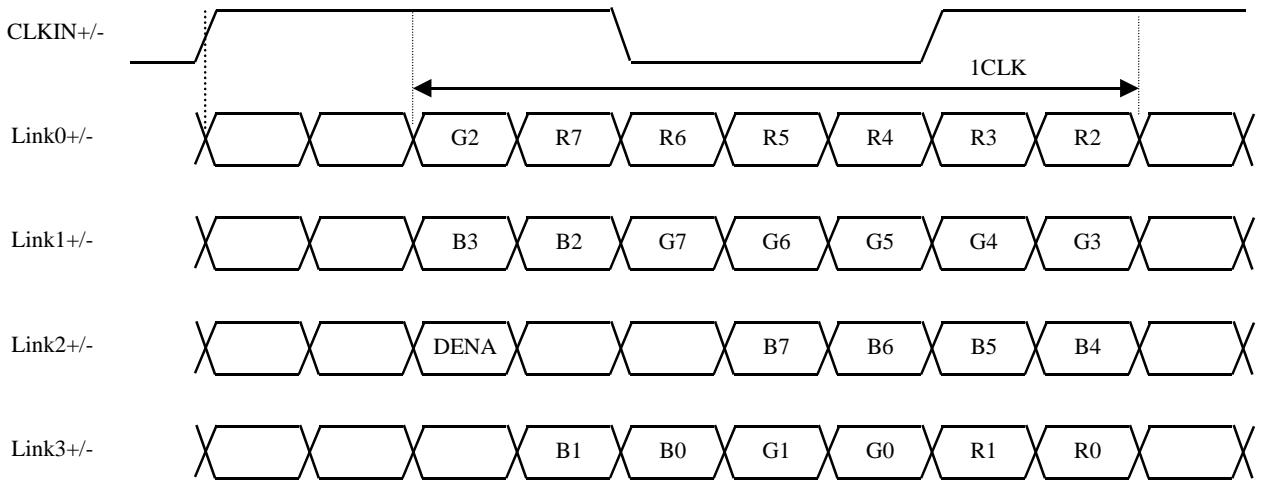

#### c. ISP 8 bit compatibility mode

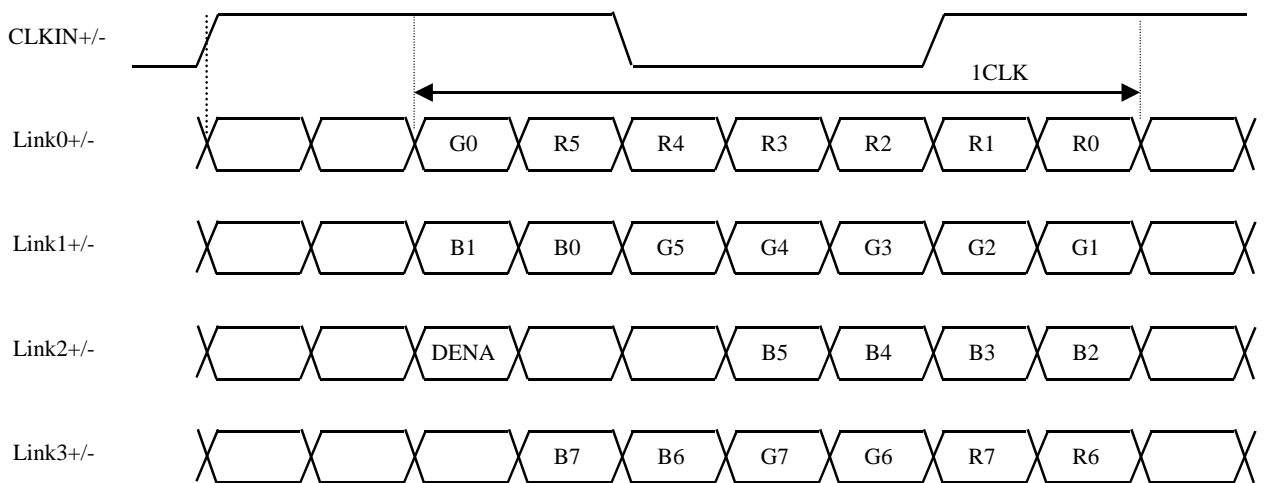



## 6. INTERFACE TIMING

LVDS transmitter input signal

### (1) Timing Specifications

ITEM		SYMBOL	MIN	TYP	MAX	UNIT	
DCLK	Frequency	f <sub>CLK</sub>	50	65	80	MHz	
	Period	t <sub>CLK</sub>	12.5	15.4	20	ns	
DENA	Horizontal	Active Time	t <sub>HA</sub>	1024	1024	1024	t <sub>CLK</sub>
		Blanking Time	t <sub>HB</sub>	20	320	--	t <sub>CLK</sub>
		Frequency	f <sub>H</sub>	42.4	48.4	60	kHz
		Period	t <sub>H</sub>	16.6	20.7	23.6	μs
	Vertical	Active Time	t <sub>VA</sub>	768	768	768	t <sub>H</sub>
		Blanking Time	t <sub>VB</sub>	3	38	--	t <sub>H</sub>
		Frequency	f <sub>V</sub>	55	60	75	Hz
		Period	t <sub>V</sub>	13.3	16.7	18.2	ms

[Note]

- 1) DENA (Data Enable) should always be positive polarity as shown in the timing specification.
- 2) DCLK should appear during all invalid period.
- 3) LVDS timing follows the timing specifications of LVDS receiver IC: THC63LVDF84B(Thine).
- 4) In case of blanking time fluctuation, please satisfy following condition.

$$t_{VBn} > t_{VBn-1} - 3(t_H)$$

(2) Timing Chart

a. Horizontal Timing Chart

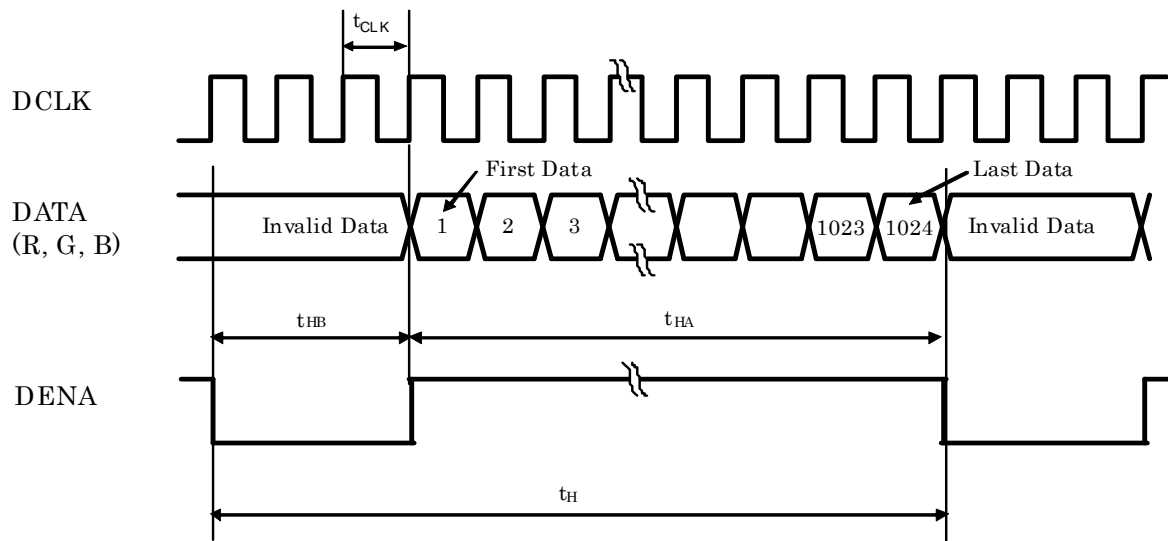

b. Vertical Timing Chart

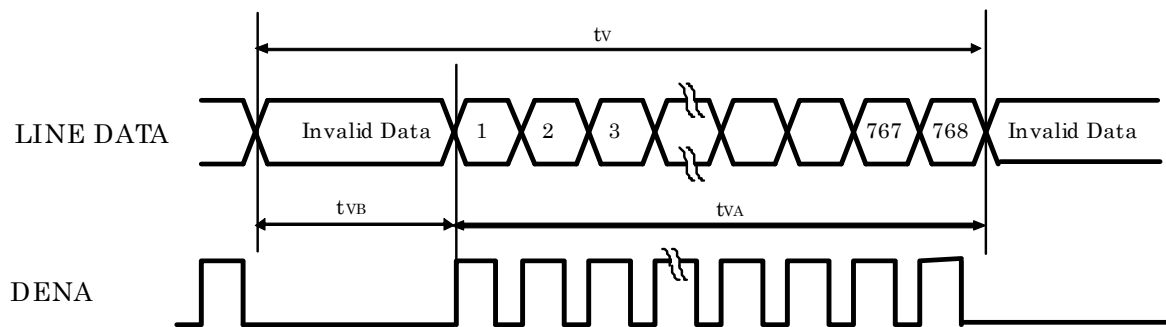

(3) Color Data Assignment

a. 6 bit input

COLOR		INPUT DATA																	
		R DATA						G DATA						B DATA					
		R5	R4	R3	R2	R1	R0	G5	G4	G3	G2	G1	G0	B5	B4	B3	B2	B1	B0
		MSB			LSB			MSB			LSB			MSB		LSB			
BASIC COLOR	BLACK	0	0	0	0	0	0	0	0	0	0	0	0	0	0	0	0	0	0
	RED(63)	1	1	1	1	1	1	0	0	0	0	0	0	0	0	0	0	0	0
	GREEN(63)	0	0	0	0	0	0	1	1	1	1	1	1	0	0	0	0	0	0
	BLUE(63)	0	0	0	0	0	0	0	0	0	0	0	0	1	1	1	1	1	1
	CYAN	0	0	0	0	0	0	1	1	1	1	1	1	1	1	1	1	1	1
	MAGENTA	1	1	1	1	1	1	0	0	0	0	0	0	1	1	1	1	1	1
	YELLOW	1	1	1	1	1	1	1	1	1	1	1	1	0	0	0	0	0	0
	WHITE	1	1	1	1	1	1	1	1	1	1	1	1	1	1	1	1	1	1
RED	RED(1)	0	0	0	0	0	1	0	0	0	0	0	0	0	0	0	0	0	0
	RED(2)	0	0	0	0	1	0	0	0	0	0	0	0	0	0	0	0	0	0
	RED(62)	1	1	1	1	1	0	0	0	0	0	0	0	0	0	0	0	0	0
	RED(63)	1	1	1	1	1	1	0	0	0	0	0	0	0	0	0	0	0	0
GREEN	GREEN(1)	0	0	0	0	0	0	0	0	0	0	0	1	0	0	0	0	0	0
	GREEN(2)	0	0	0	0	0	0	0	0	0	0	1	0	0	0	0	0	0	0
	GREEN(62)	0	0	0	0	0	0	1	1	1	1	1	0	0	0	0	0	0	0
	GREEN(63)	0	0	0	0	0	0	1	1	1	1	1	1	0	0	0	0	0	0
BLUE	BLUE(1)	0	0	0	0	0	0	0	0	0	0	0	0	0	0	0	0	0	1
	BLUE(2)	0	0	0	0	0	0	0	0	0	0	0	0	0	0	0	0	1	0
	BLUE(62)	0	0	0	0	0	0	0	0	0	0	0	0	1	1	1	1	1	0
	BLUE(63)	0	0	0	0	0	0	0	0	0	0	0	0	1	1	1	1	1	1

[Note]

- 1) Definition of gray scale  
 Color (n) --- n indicates gray scale level.  
 Higher n means brighter level.
- 2) Data  
 1:High, 0: Low

b. 8 bit input

COLOR		INPUT DATA																							
		R DATA								G DATA								B DATA							
		R7	R6	R5	R4	R3	R2	R1	R0	G7	G6	G5	G4	G3	G2	G1	G0	B7	B6	B5	B4	B3	B2	B1	B0
		MSB				LSB				MSB				LSB				MSB				LSB			
BASIC COLOR	BLACK	0	0	0	0	0	0	0	0	0	0	0	0	0	0	0	0	0	0	0	0	0	0	0	0
	RED(255)	1	1	1	1	1	1	1	1	0	0	0	0	0	0	0	0	0	0	0	0	0	0	0	0
	GREEN(255)	0	0	0	0	0	0	0	0	1	1	1	1	1	1	1	1	0	0	0	0	0	0	0	0
	BLUE(255)	0	0	0	0	0	0	0	0	0	0	0	0	0	0	0	0	1	1	1	1	1	1	1	1
	CYAN	0	0	0	0	0	0	0	0	1	1	1	1	1	1	1	1	1	1	1	1	1	1	1	1
	MAGENTA	1	1	1	1	1	1	1	1	0	0	0	0	0	0	0	0	1	1	1	1	1	1	1	1
	YELLOW	1	1	1	1	1	1	1	1	1	1	1	1	1	1	1	1	0	0	0	0	0	0	0	0
	WHITE	1	1	1	1	1	1	1	1	1	1	1	1	1	1	1	1	1	1	1	1	1	1	1	1
RED	RED(1)	0	0	0	0	0	0	0	1	0	0	0	0	0	0	0	0	0	0	0	0	0	0	0	0
	RED(2)	0	0	0	0	0	0	1	0	0	0	0	0	0	0	0	0	0	0	0	0	0	0	0	0
	RED(255)	1	1	1	1	1	1	1	1	0	0	0	0	0	0	0	0	0	0	0	0	0	0	0	0
GREEN	GREEN(1)	0	0	0	0	0	0	0	0	0	0	0	0	0	0	0	1	0	0	0	0	0	0	0	0
	GREEN(2)	0	0	0	0	0	0	0	0	0	0	0	0	0	0	1	0	0	0	0	0	0	0	0	0
	GREEN(255)	0	0	0	0	0	0	0	0	1	1	1	1	1	1	1	1	0	0	0	0	0	0	0	0
BLUE	BLUE(1)	0	0	0	0	0	0	0	0	0	0	0	0	0	0	0	0	0	0	0	0	0	0	0	1
	BLUE(2)	0	0	0	0	0	0	0	0	0	0	0	0	0	0	0	0	0	0	0	0	0	0	1	0
	BLUE(255)	0	0	0	0	0	0	0	0	0	0	0	0	0	0	0	0	1	1	1	1	1	1	1	1

[Note]

1) Definition of gray scale

Color (n) --- n indicates gray scale level.

Higher n means brighter level.

2) Data

1:High, 0: Low

(4) Display Position and Scan Direction

D(X,Y) shows the data number of input signal.

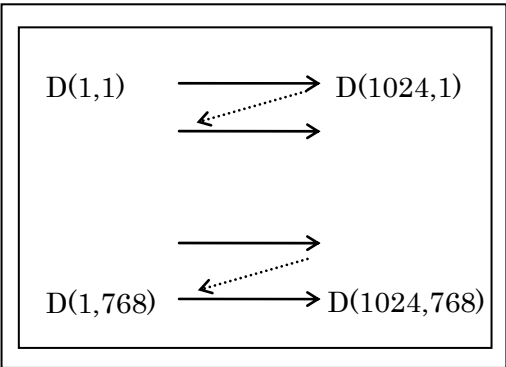

## 7. BLOCK DIAGRAM

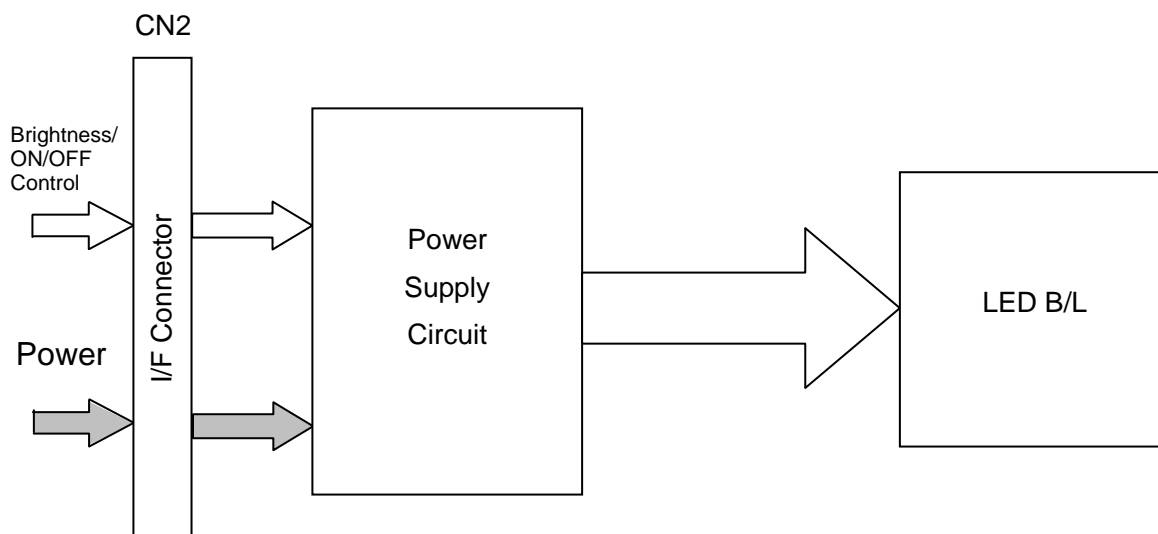
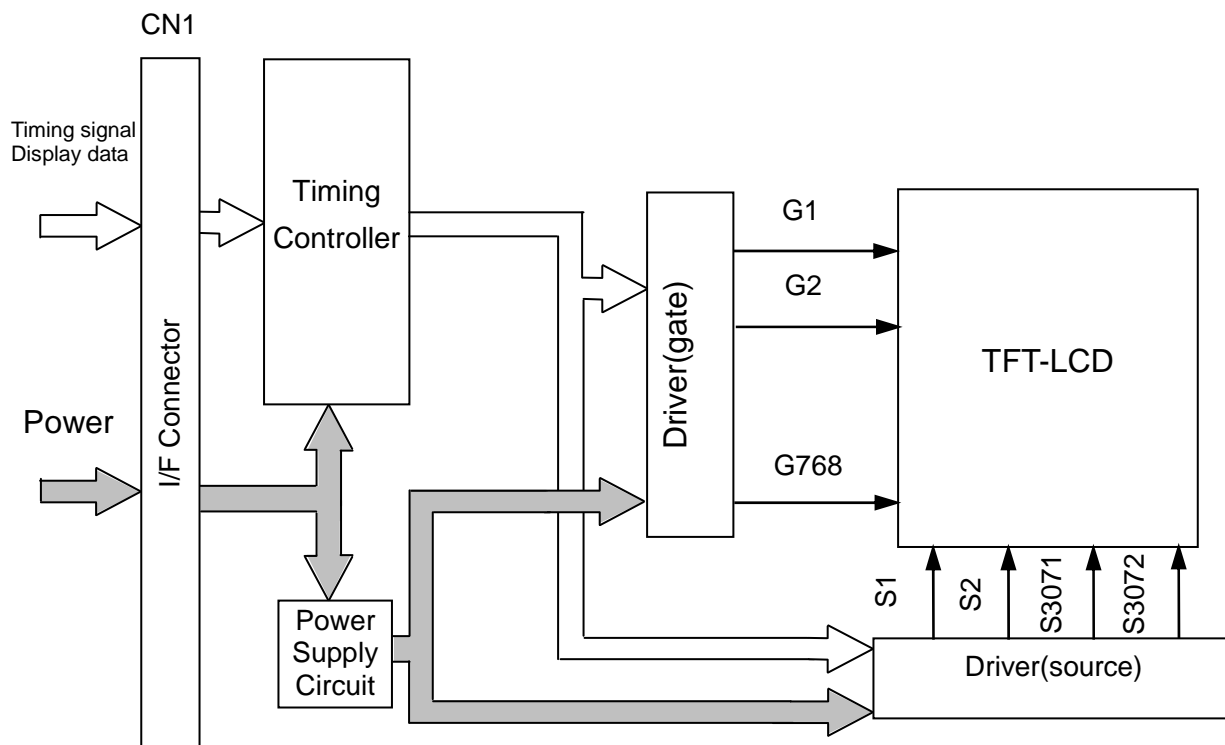

# 8. MECHANICAL SPECIFICATIONS

(1) Front Side

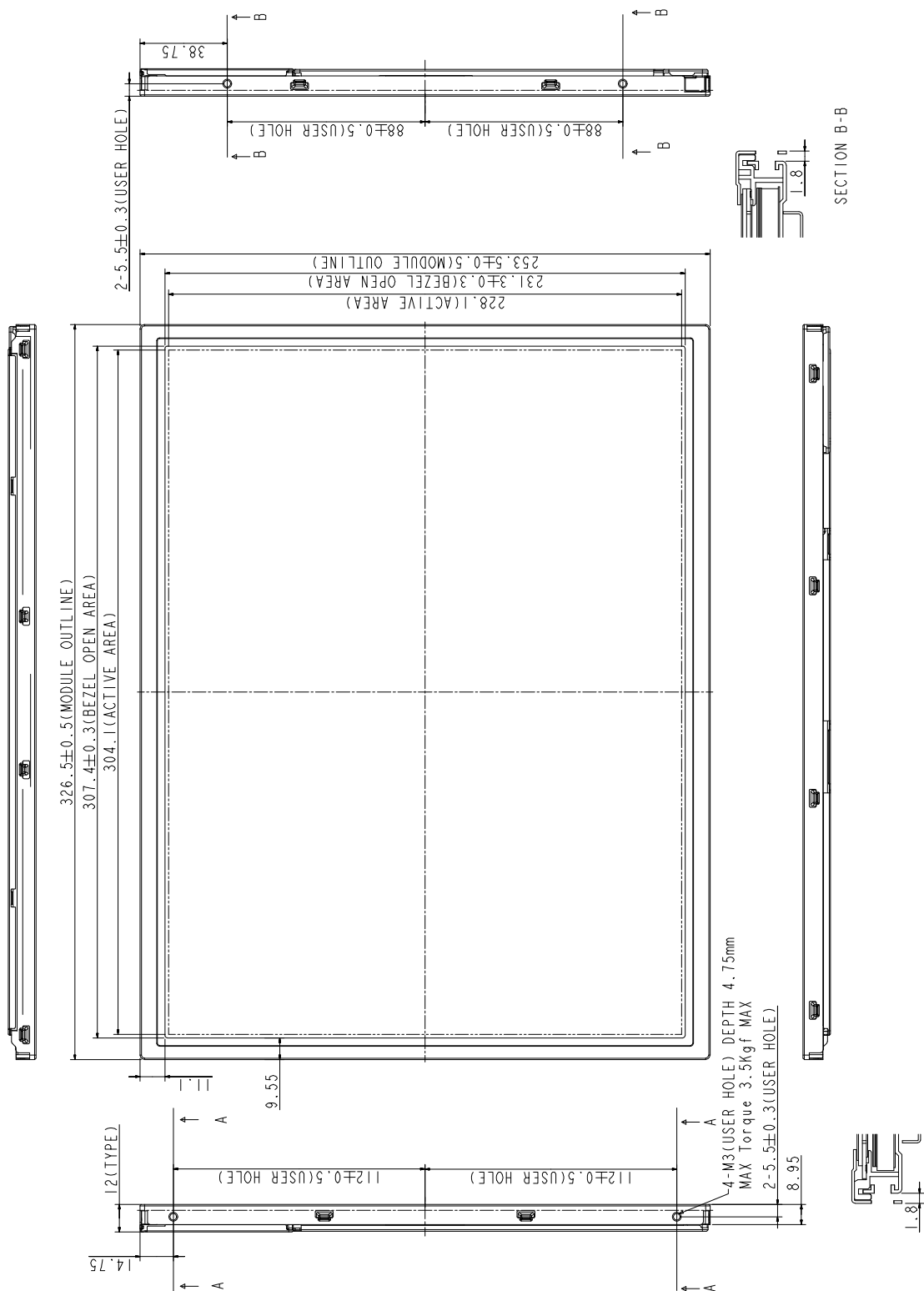

(Unit: mm)

- 1)Tolerance is ±0.5mm unless noted.
- 2)Third angle projection

(2) Rear Side

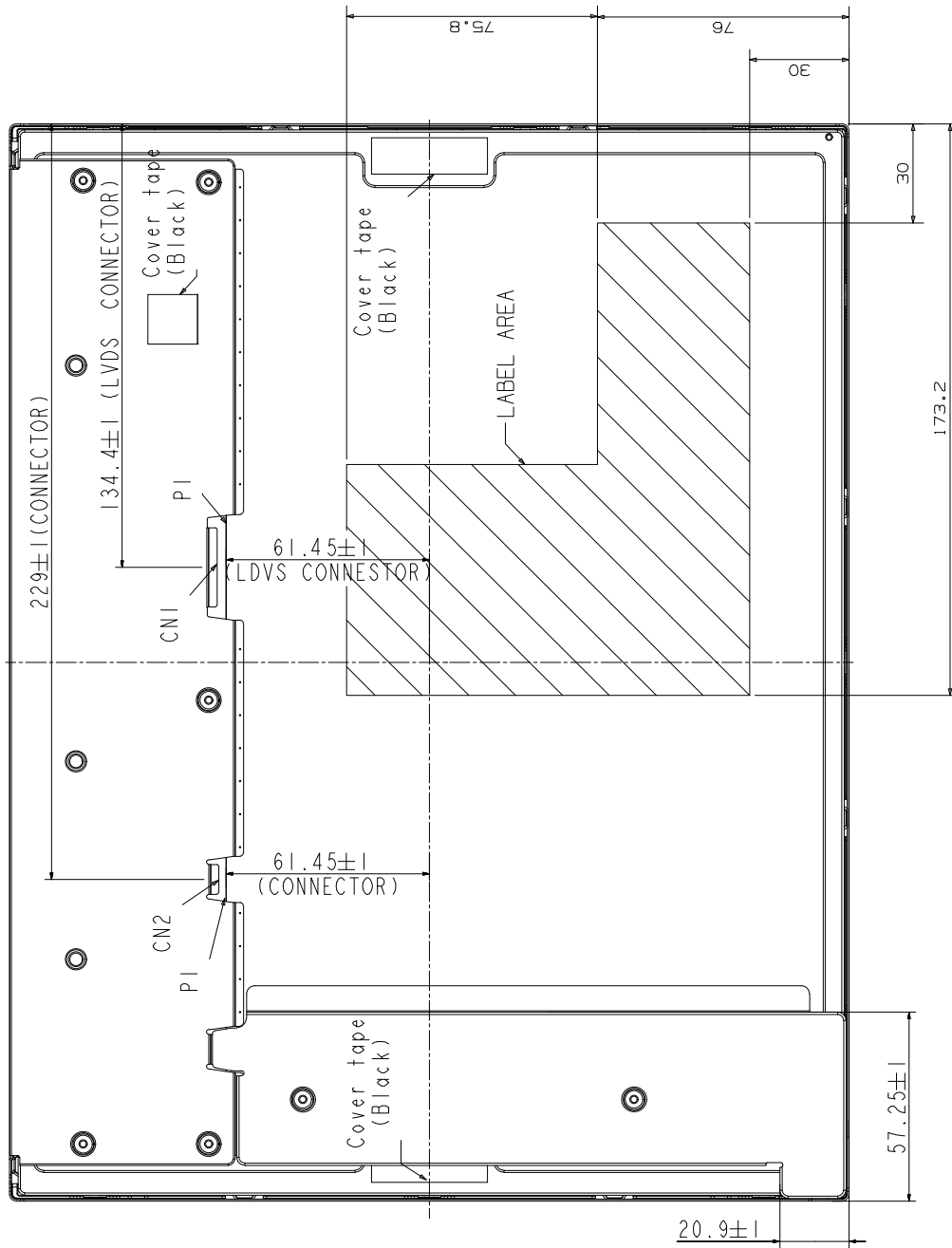

CN1 : MSB240420HD (STM) or DF14H-20P-1.25(56) (HIROSE)

CN2 : CR03-P06H2B-2 (CONNTEK)

- 1) Tolerance is  $\pm 0.5$ mm unless noted.
- 2) Third angle projection

(Unit: mm)



## 9. OPTICAL CHARACTERISTICS

Ta=25°C, VCC=3.3V, VL=12.0V, Input Signals: Typ. values shown in Section 6

ITEM	SYMBOL	CONDITION	MIN	TYP	MAX	UNIT	Remarks	
Contrast Ratio	CR	$\theta_V=0^\circ, \theta_H=0^\circ$	450	700	--	--	*1)*2)*4)	
Luminance	Lw	$\theta_V=0^\circ, \theta_H=0^\circ$	360	380	--	cd/m <sup>2</sup>	*1)*4)	
Luminance Uniformity	$\Delta Lw$	$\theta_V=0^\circ, \theta_H=0^\circ$	75	--	--	%	*1)*3)*4)	
Response Time	tr	$\theta_V=0^\circ, \theta_H=0^\circ$	--	2	--	ms	*1)*4)*5)	
	tf	$\theta_V=0^\circ, \theta_H=0^\circ$	--	10	--	ms	*1)*4)*5)	
Viewing Angle	Horizontal	$\theta_H$	CR $\geq$ 10	-65~65	-80~80	--	°	*1)*4)
	Vertical	$\theta_V$		-55~55	-70~70	--	°	*1)*4)
Image sticking	tis	2 h	--	--	2	s	--	
Color Coordinates	Red	Rx	$\theta_V=0^\circ, \theta_H=0^\circ$	0.584	0.634	0.684	--	*1)*4)
		Ry		0.295	0.345	0.395		
	Green	Gx		0.295	0.345	0.395		
		Gy		0.545	0.595	0.645		
	Blue	Bx		0.100	0.150	0.200		
		By		0.023	0.073	0.123		
	White	Wx		0.263	0.313	0.363		
		Wy		0.279	0.329	0.379		

[Note]

These items are measured using SR-UL1R(TOPCON) for color coordinates, and BM-5A (TOPCON) for others under the dark room condition. (no ambient light) after more than 20 minutes from turning on the backlight unless noted.

Condition: V<sub>PDIM</sub> = 1.8V ~ 5.0V DC

Measurement method for luminance and color coordinates is as follows.

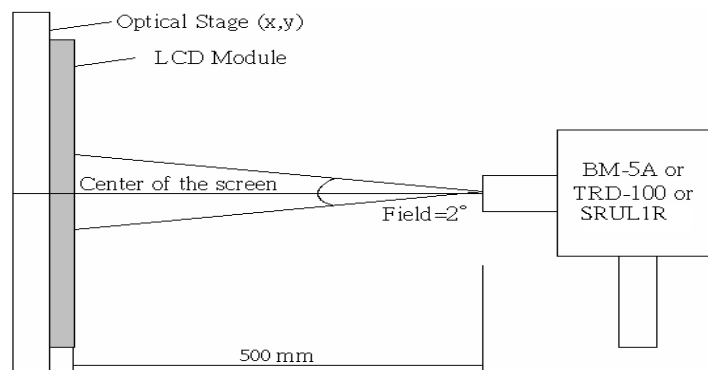

\*1) Measurement Point

Contrast Ratio, Luminance, Response Time, Viewing Angle, Color Coordinates: Display Center  
 Luminance Uniformity: point 1~9 shown in a figure below

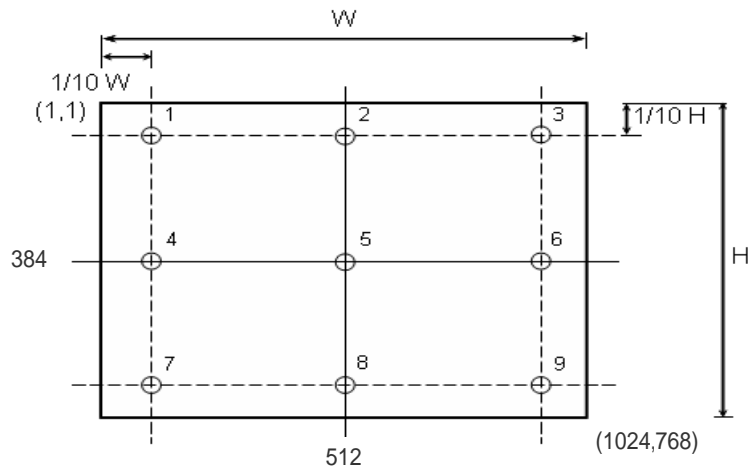

\*2) Definition of Contrast Ratio

$CR = \text{Luminance with all white pixels} / \text{Luminance with all black pixels}$

\*3) Definition of Luminance Uniformity

$L_w = [L_w(\text{Min}) / L_w(\text{Max})] \times 100\%$

\*4) Definition of Viewing Angle ( $\theta_v$ ,  $\theta_H$ )

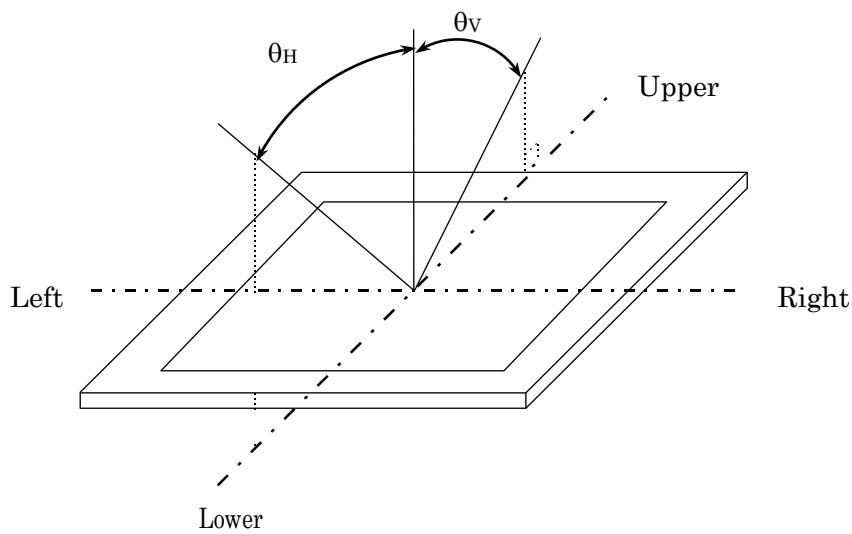

\*5) Definition of Response Time

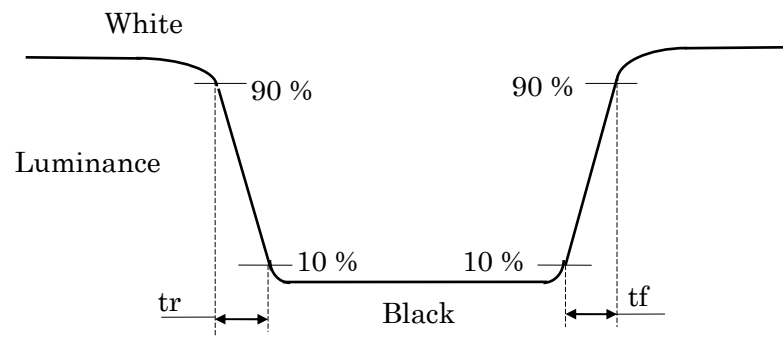

## 10. RELIABILITY TEST CONDITION

### (1) Temperature and Humidity

TEST ITEM	CONDITIONS
HIGH TEMPERATURE HIGH HUMIDITY OPERATION	40°C, 90%RH, 240 h (No condensation)
HIGH TEMPERATURE OPERATION	65°C, 240 h
LOW TEMPERATURE OPERATION	0°C, 240 h
HIGH TEMPERATURE STORAGE	65°C, 240 h
LOW TEMPERATURE STORAGE	-20°C, 240 h
THERMAL SHOCK (NON-OPERATION)	-20°C (0.5 h) ~ 65°C (0.5 h), 100 cycles

### (2) Shock & Vibration

ITEM	CONDITIONS
SHOCK (NON-OPERATION)	Shock level: 1470 m/s <sup>2</sup> (150G) Waveform: half sinusoidal wave, 2 ms Number of shocks: one shock input in each direction of three mutually perpendicular axes for a total of six shock inputs
VIBRATION (NON-OPERATION)	Vibration level: 9.8 m/s <sup>2</sup> (1.0G) Waveform: sinusoidal Frequency range: 5 to 500 Hz Frequency sweep rate: 0.5 octave /min Duration: one sweep from 5 to 500 Hz in each of three mutually perpendicular axis(each x,y,z axis: 1 hour, total 3 hours)

### (3) ESD Test

ITEM	CONDITIONS
CONTACT DISCHARGE (OPERATION)	150pF, 330Ω, ±8kV, 10 times at 1 sec interval
SIGNAL PIN DISCHARGE (NON-OPERATION)	200pF, 0Ω, ±200V, 10 times at 1 sec interval

### (4) Judgment standard

The judgment of the above tests should be made as follow:

Pass: Normal display image, no damage of the display function. (ex. no line defect)

Partial transformation of the module parts should be ignored.

Fail: No display image, damage of the display function. (ex. line defect)

## 11. OTHER FEATURE

This LCD module complies with RoHS\*) directive.

\*) RoHS: Restriction of the use of certain hazardous substances in electrical and electronic equipment

UL60950-1 certified (UL File# E194548)

## 12. HANDLING PRECAUTIONS FOR TFT-LCD MODULE

Please pay attention to the followings in handling TFT-LCD products:

### (1) ASSEMBLY PRECAUTION

- a. Please mount the LCD module by using mounting hole with a screw clamping torque less than 0.36 Nm. Please do not bend or wrench the LCD module in assembling. Please do not drop, bend or twist the LCD module in handling.
- b. Please design display housing in accordance with the following guide lines.
  - (a) Housing case must be designed carefully so as not to put stresses on LCD and not to wrench module.
  - (b) Under high temperature environment, performance and life time of LED may heavily shorten. When you design with our LCD product, please consider radiating heat and ventilation for good heat management.
  - (c) Keep sufficient clearance between LCD module back surface and housing when the LCD module is mounted. Approximately 1.0mm of the clearance in the design is recommended taking into account the tolerance of LCD module thickness and mounting structure height on the housing.
  - (d) When some parts, such as, FPC cable and ferrite plate, are installed underneath the LCD module, still sufficient clearance is required, such as 0.5mm. This clearance is, especially, to be reconsidered when the additional parts are implemented for EMI countermeasure.
  - (e) Keep sufficient clearance between LCD module and the others parts, such as inverter and speaker so as not to interfere the LCD module. Approximately 1.0 mm of the clearance in the design is recommended.
  - (f) To avoid local elevation/decrease of temperature, considering location of heating element, heat release, thermal design should be done.
- c. Please do not push or scratch LCD panel surface with anything hard. And do not soil LCD panel surface by touching with bare hands. (Polarizer film, surface of LCD panel is easy to be flawed.)
- d. Please wipe off LCD panel surface with absorbent cotton or soft cloth in case of it being soiled.
- e. Please wipe off drops of adhesives like saliva and water on LCD panel surface immediately. They might damage to cause panel surface variation and color change.
- f. Please do not take a LCD module to pieces and reconstruct it. Resolving and reconstructing modules may cause them not to work well.
- g. Please do not touch metal frames with bare hands and soiled gloves. A color change of the metal frames can happen during a long preservation of soiled LCD modules.
- h. Please handle metal frame carefully because edge of metal frame is very sharp.

- i. Please connect the metal frame of LCD module to GND in order to minimize the effect of external noise and EMI.
- j. Be sure to connect the cables and the connectors correctly.

## **(2) OPERATING PRECAUTIONS**

- a. Please be sure to turn off the power supply before connecting and disconnecting signal input cable.
- b. Please do not change variable resistance settings in LCD module. They are adjusted to the most suitable value. If they are changed, it might happen LCD does not satisfy the characteristics specification.
- c. The interface signal speed is very high. Please pay attention to transmission line design and other high speed signal precautions to satisfy signal specification.
- d. Condensation might happen on the surface and inside of LCD module in case of sudden change of ambient temperature. Please take care so as not to cause any damage mentioned on (1)-d.
- e. Please pay attention not to display the same pattern for very long time. Image sticking might happen on LCD. Although image sticking may disappear as the operation time proceeds, screen saver function is recommended not to cause image sticking.
- f. Please obey the same safe instructions as ones being prepared for ordinary electronic products.

## **(3) PRECAUTIONS WITH ELECTROSTATICS**

- a. This LCD module use CMOS-IC on circuit board and TFT-LCD panel, and so it is easy to be affected by electrostatics. Please be careful with electrostatics by the way of your body connecting to the ground and so on.
- b. Please remove protection film very slowly from the surface of LCD module to prevent from electrostatics occurrence.

## **(4) STORAGE PRECAUTIONS**

LCD should be stored in the room temperature environment with normal humidity. The LCD inventory should be processed by first-in first-out method.

## **(5) SAFETY PRECAUTIONS**

- a. When you waste damaged or unnecessary LCDs, it is recommended to crush LCDs into pieces and wash them off with solvents such as acetone and ethanol, which should later be burned.
- b. If any liquid leaks out of a damaged glass cell and comes in contact with the hands, wash off thoroughly with soap and water.