

PREPARED BY : DATE	<h1>SHARP</h1> <p>TFT LCD DEVELOPMENT GROUP SHARP CORPORATION</p> <h2>SPECIFICATION</h2>	SPEC No. LD-13110A
		FILE No.
APPROVED BY : DATE		ISSUE : Mar.16.2001
		PAGE : 18 Pages
		APPLICABLE GROUP TFT Liquid Crystal Display Group

DEVICE SPECIFICATION

TFT-LCD Module

MODEL

LQ181E1DG44

CUSTOMER'S APPROVAL

DATE _____

BY _____

PRESENTED

BY *K. Shiono*

K.SHIONO

Manager

Development Engineering Department 3

TFT Division 2

TFT LIQUID CRYSTAL DISPLAY GROUP

SHARP CORPORATION

RECORDS OF REVISION

LQ181E1DG44

SPEC No.	DATE	REVISED		SUMMARY	NOTE
		No.	PAGE		
LD-13110	Feb. 1.2001	-	-	-	1st Issue
LD-13110A	Mar.16.2001	1	15	Change the area of core	
		2	14	Change the label	

1. Application

This specifications applies to the color 18.1" SXGA TFT-LCD module LQ181E1DG44.

These specification sheets are the proprietary product of SHARP CORPORATION("SHARP) and include materials protected under copyright of SHARP. Do not reproduce or cause any third party to reproduce them in any form or by any means, electronic or mechanical, for any purpose, in whole or in part, without the express written permission of SHARP .

The device listed in these specification sheets was designed and manufactured for use in OA equipment .

In case of using the device for applications such as control and safety equipment for transportation(aircraft, trains, automobiles, etc.), rescue and security equipment and various safety related equipment which require higher reliability and safety, take into consideration that appropriate measures such as fail-safe functions and redundant system design should be taken .

Do not use the device for equipment that requires an extreme level of reliability, such as aerospace applications, telecommunication equipment (trunk lines), nuclear power control equipment and medical or other equipment for life support .

SHARP assumes no responsibility for any damage resulting from the use of the device which does not comply with the instructions and the precautions specified in these specification sheets .

Contact and consult with a SHARP sales representative for any questions about this device .

2. Overview

This module is a color active matrix LCD module incorporating amorphous silicon TFT (Thin Film Transistor). It is composed of a color TFT-LCD panel, driver ICs, control circuit, power supply circuit and a back light unit. Graphics and texts can be displayed 1280*3*1024 dots on a panel with about 16 million colors (8 bit) by supplying 48 bit data signals(8 bit*2pixel *RGB), two timing signals, +12V DC supply voltage for TFT-LCD panel driving and supply voltage for back light.

3. Mechanical Specifications

Parameter	Specifications	Unit
Display size	48 (Diagonal)	cm
	18.1 (Diagonal)	inch
Active area	359.0 (H) × 287.2 (V)	mm
Pixel format	1280 (H) × 1024 (V)	pixel
	(1 pixel = R + G + B dots)	
Pixel pitch	0.2805 (H) × 0.2805 (V)	mm
Pixel configuration	R,G,B vertical stripe	
Display mode	Normally white	
Unit outline dimensions *1	408.0 (W) × 335.6 (H) × 14.0(D)	mm
Mass	2200±150	g
Surface treatment	Anti-glare and hard-coating 2H (Haze value = 28)	

*1.Note: excluding back light cables .

The thickness of module (D) doesn't contain the projection.

Outline dimension is shown in Fig.1

4. Input Terminals

4-1. TFT-LCD panel driving

CN1 (Interface signals and +12VDC power supply)

The module-side connector : FX10B-100P/10-SV (Hirose Electric Co., Ltd.)

The user-side connector : FX10A-100S/10-SV (Hirose Electric Co., Ltd.)

FX10B-100S/10-SV (Hirose Electric Co., Ltd.)

CN1

Pin No.	Symbol	Function	Pin No.	Symbol	Function
1	Vcc	+12V power supply	2	Vcc	+12V power supply
3	Vcc	+12V power supply	4	Vcc	+12V power supply
5	Vcc	+12V power supply	6	Vcc	+12V power supply
7	GND		8	GND	
9	OPEN	Reserve	10	BLON	Back light ON signal 【Note 1】
	GND	Fixed GND	-	GND	Fixed GND
11	GND		12	GND	
13	RB7	B port red data (MSB)	14	RA7	A port red data (MSB)
15	RB6	B port red data	16	RA6	A port red data
17	GND		18	GND	
19	RB5	B port red data	20	RA5	A port red data
21	RB4	B port red data	22	RA4	A port red data
23	GND		24	GND	
25	RB3	B port red data	26	RA3	A port red data
27	RB2	B port red data	28	RA2	A port red data
29	GND		30	GND	
-	GND	Fixed GND	-	GND	Fixed GND
31	GND		32	GND	
33	RB1	B port red data	34	RA1	A port red data
35	RB0	B port red data (LSB)	36	RA0	A port red data (LSB)
37	GND		38	GND	
39	GB7	B port green data (MSB)	40	GA7	A port green data (MSB)
41	GB6	B port green data	42	GA6	A port green data
43	GND		44	GND	
45	GB5	B port green data	46	GA5	A port green data
47	GB4	B port green data	48	GA4	A port green data
49	GND		50	GND	
-	GND	Fixed GND	-	GND	Fixed GND
51	GND		52	GND	
53	GB3	B port green data	54	GA3	A port green data
55	GB2	B port green data	56	GA2	A port green data
57	GND		58	GND	
59	GB1	B port green data	60	GA1	A port green data
61	GB0	B port green data (LSB)	62	GA0	A port green data (LSB)
63	GND		64	GND	
65	CLKB	B port clock	66	CLKA	A port clock
67	GND		68	GND	
69	DEB	B port enable	70	DEA	A port enable
-	GND	Fixed GND	-	GND	Fixed GND
71	GND		72	GND	
73	BB7	B port blue data (MSB)	74	BA7	A port blue data (MSB)
75	BB6	B port blue data	76	BA6	A port blue data
77	GND		78	GND	
79	BB5	B port blue data	80	BA5	A port blue data
81	BB4	B port blue data	82	BA4	A port blue data
83	GND		84	GND	
85	BB3	B port blue data	86	BA3	A port blue data
87	BB2	B port blue data	88	BA2	A port blue data
89	GND		90	GND	
-	GND	Fixed GND	-	GND	Fixed GND
91	BB1	B port blue data	92	BA1	A port blue data
93	BB0	B port blue data (LSB)	94	BA0	A port blue data (LSB)
95	GND		96	GND	
97	GND		98	GND	
99	GND		100	GND	

【Note】 This module has dual pixel port to receive dual pixel data at the same time . A port receives first pixel data and B port receives second pixel data in dual pixel data.

【Note 1】 BLON: It change from L to H at 7 frames after DE,CK activated.

4-2. Back light driving

CN2,CN3,CN4,CN5 The module-side connector : BHSR-02VS-1(JST)

The user-side connector : SM02(4.0)B-BHS(JST)

Pin No.	Symbol	Function
1	VHIGH	Power supply for lamp (High voltage side)
2	VLOW	Power supply for lamp (Low voltage side)

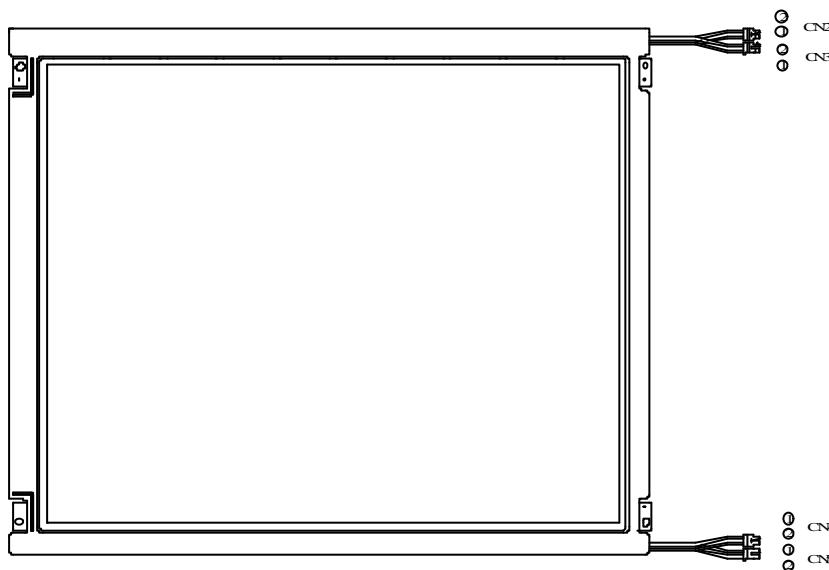

5. Absolute Maximum Ratings

Parameter	Symbol	Condition	Ratings	Unit	Remark
Input voltage	V_I	$T_a=25$	-0.3 ~ +3.6	V	【Note1】
+12.0V supply voltage	V_{cc}	$T_a=25$	0 ~ +14.0	V	
Storage temperature	T_{stg}	-	-25 ~ +60		【Note2】
Operating temperature (Ambient)	T_{opa}	-	0 ~ +50		

【Note1】 CLKA,CLKB,DEA,DEB,RA0-RA7,GA0-GA7,BA0-BA7, RB0-RB7,GB0-GB7,BB0-BB7

【Note2】 Humidity : 95%RH Max. ($T_a < 40$)

Maximum wet-bulb temperature at 39 or less ($T_a > 40$)

No condensation.

6. Electrical Characteristics

6-1. TFT-LCD panel driving

Ta = 25

Parameter		Symbol	Min.	Typ.	Max.	Unit	Remark
Vcc	Supply voltage	Vcc	+11.4	+12.0	+12.6	V	【Note1】
	Current dissipation	Icc	-	370	550	mA	【Note2】
Permissive input ripple voltage		V _{RF}	-	-	100	mVp-p	
Input voltage (Low)		V _{IL}	GND	-	0.6	V	【Note3】
Input voltage (High)		V _{IH}	2.25	3.0	3.3	V	【Note3】
Input current (Low)		I _{IL}	-	-	10	μA	V _I =GND 【Note3】
Input current (High)		I _{IH}	-	-	10	μA	V _I =Vcc 【Note3】

【Note1】 On-Off conditions for supply voltage

$$0 < t1 \quad 10\text{ms}$$

$$0 < t2 \quad 10\text{ms}$$

$$0 < t3 \quad 1\text{s}$$

$$t4 \quad 1\text{s}$$

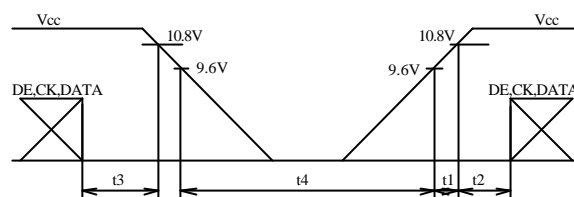

Vcc-dip conditions

$$1) \quad +9.6\text{V} \quad V_{cc} < +10.8\text{V}$$

$$t_d \quad 10\text{ms}$$

$$2) \quad V_{cc} < +9.6\text{V}$$

Vcc-dip conditions should also follow the on-off conditions

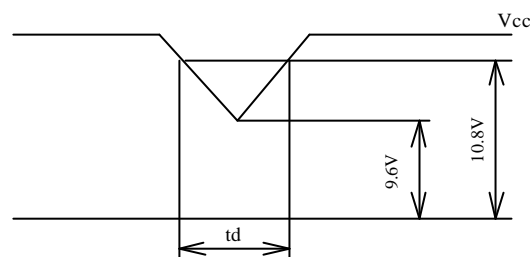

【Note2】 Typical current situation : 256-gray-bar pattern.

$$V_{cc}=+12.0\text{V}, \text{CK}=55\text{MHz}$$

The explanation of each gray scale is described below section (8).

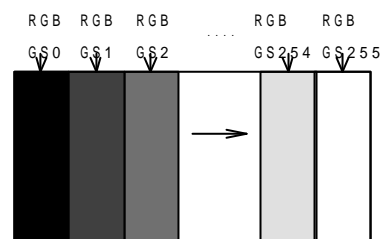

【Note3】 CLKA,CLKB,DEA,DEB,RA0-RA7,GA0-GA7,BA0-BA7, RB0-RB7,GB0-GB7,BB0-BB7

6-2. Back light driving

The back light system is an edge-lighting type with a four of CCFT (Cold Cathode Fluorescent Tube).

The characteristics of the lamp are shown in the following table.

The value mentioned below is at the case of one CCFT.

CCFT Model Name : MBT26B7RX377NRU/G (HARISON TOSHIBA LIGHTING Corp.)

Parameter	Symbol	Min.	Typ.	Max.	Unit	Remark
Lamp current range	I_L	2.5	6.0	6.5	mArms	【Note1】
Lamp voltage	V_L	-	720	-	Vrms	Ta=25
Lamp power consumption	P_L	-	4.32	-	W	【Note2】
Lamp frequency	F_L	35	60	70	KHz	【Note3】
Kick-off voltage	V_s	-	-	1300	Vrms	Ta=25 【Note4】
		-	-	1600	Vrms	Ta=0 【Note4】
Lamp life time	L_L	50000	-	-	hour	【Note5】

【Note1】 A lamp can be light in the range of lamp current shown above.

Maximum rating for current is measured by high frequency current measurement equipment connected to V_{LOW} at circuit showed below .

(Note : To keep enough kick-off voltage and necessary steady voltage for CCFT .)

Lamp frequency : 35 ~ 70kHz

Ambient temperature : 0 ~ 50

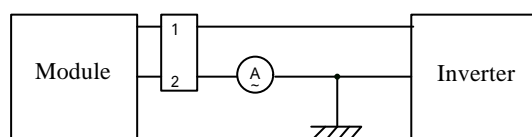

* 2pin is V_{LOW}

【Note2】 Referential data per one CCFT by calculation ($I_L \times V_L$) .

The data doesn't include loss at inverter .

【Note3】 Lamp frequency of inverter may produce interference with horizontal synchronous frequency, and this may cause horizontal beat on the display. Therefore, adjust lamp frequency, and keep inverter as far as from module or use electronic shielding between inverter and module to avoid interference.

【Note4】The voltage above this value should be applied to the lamp for more than 1 second to startup. Otherwise the lamp may not be turned on .

【Note5】 Lamp life time is defined as the time when either or occurs in the continuous operation under the condition of Ta=25 and $I_L=6.0 \pm 0.5$ mArms .

Brightness becomes 50% of the original value under standard condition.

Kick-off voltage at Ta=0 exceeds maximum value, 1600Vrms .

《Note》 The performance of the back light, for example life time or brightness, is much influenced by the characteristics of the DC-AC inverter for the lamp .When you design or order the inverter, please make sure that a poor lighting caused by the mismatch of the back light and the inverter (miss-lighting, flicker, etc.) never occurs. When you confirm it, the module should be operated in the same condition as it is installed in your instrument.

Use the lamp inverter power source incorporating such safeguard as overvoltage / overcurrent protective circuit or lamp voltage waveform detection circuit, which should have individual control of each lamp.

In case one circuit without such individual control is connected to more than two lamps, excessive current may flow into one lamp when the other one is not in operation.

7. Timing characteristics of input signals

7-1. Timing characteristics

Timing diagrams of input signal are shown in Fig.4.

Parameter		Symbol	Min.	Typ.	Max.	Unit	Remark
Clock	Frequency	1/Tc	-	55	60	MHz	【Note1】
	High time	Tch	3	-	-	ns	
	Low time	Tcl	3	-	-	ns	
	Skew	Tcsq	-1	0	1	clock	
Data	Setup time	Tds	4	-	-	ns	
	Hold time	Tdh	3	-	-	ns	
Data enable	Setup time	Tes	4	-	Tc-7	ns	
signal	Hold time	Teh	3	-	-	ns	
	Horizontal period	TH	14	15	-	μs	
			648	848	928	clock	
	Horizontal period (High)	THp	10	1024	1024	clock	
	Vertical period	TV	770	806	990	line	【Note2】
Vertical blanking width	TVb	2	38	222	line		

【Note1】 Two pixel-data are sampled at the same time.

【Note2】 In case of using the long vertical period, the deterioration of display quality, flicker etc. may occur.

There should be integral horizontal period per one vertical period.

7-2. Input Data Signals and Display Position on the screen

Graphics and texts can be displayed on a 1280 × 3 × 1024 dots panel with 16M colors by supplying 48 bit data signal (8bit/color [256 gray scales] × 3 × 2 pixels).

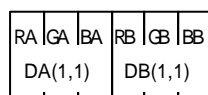

Two pixel-data are sampled at the same time.

* DA(A port) : RA0 ~ RA7, GA0 ~ GA7, BA0 ~ BA7

* DB(B port) : RB0 ~ RB7, GB0 ~ GB7, BB0 ~ BB7

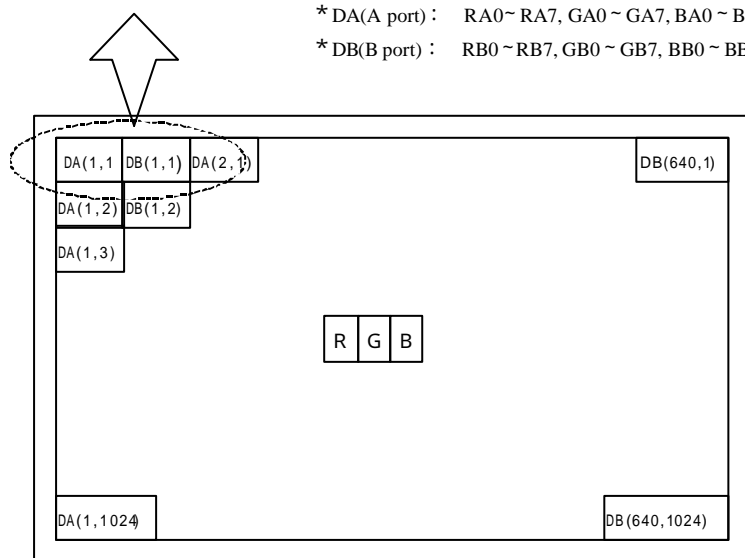

Display position of input data (H,V)

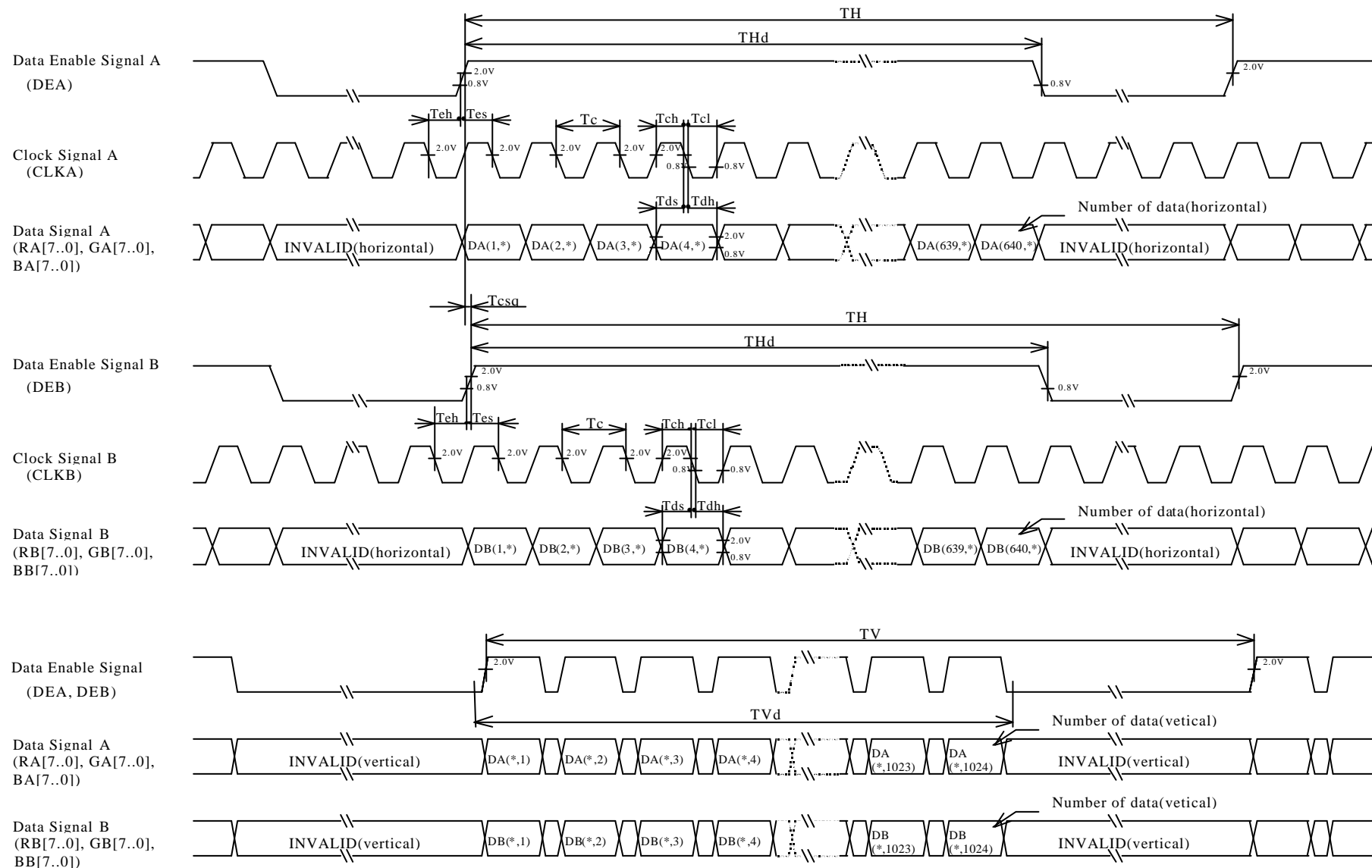

Fig.4 Input Signal Waveforms

8. Input Signals, Basic Display Colors and Gray Scale of Each Color

Colors & Gray scale	Gray Scale	Data signal																								
		RA0	RA1	RA2	RA3	RA4	RA5	RA6	RA7	GA0	GA1	GA2	GA3	GA4	GA5	GA6	GA7	BA0	BA1	BA2	BA3	BA4	BA5	BA6	BA7	
		RB0	RB1	RB2	RB3	RB4	RB5	RB6	RB7	GB0	GB1	GB2	GB3	GB4	GB5	GB6	GB7	BB0	BB1	BB2	BB3	BB4	BB5	BB6	BB7	
Basic Color	Black	-	0	0	0	0	0	0	0	0	0	0	0	0	0	0	0	0	0	0	0	0	0	0	0	0
	Blue	-	0	0	0	0	0	0	0	0	0	0	0	0	0	0	0	0	1	1	1	1	1	1	1	1
	Green	-	0	0	0	0	0	0	0	0	0	0	0	0	0	0	0	0	1	1	1	1	1	1	1	1
	Cyan	-	0	0	0	0	0	0	0	0	0	0	0	0	0	0	0	0	1	1	1	1	1	1	1	1
	Red	-	1	1	1	1	1	1	1	1	1	1	1	1	1	1	1	1	0	0	0	0	0	0	0	0
	Magenta	-	1	1	1	1	1	1	1	1	1	1	1	1	1	1	1	1	0	0	0	0	0	0	0	0
	Yellow	-	1	1	1	1	1	1	1	1	1	1	1	1	1	1	1	1	1	1	1	1	1	1	1	1
	White	-	1	1	1	1	1	1	1	1	1	1	1	1	1	1	1	1	1	1	1	1	1	1	1	1
Gray Scale of Red	Black	GS0	0	0	0	0	0	0	0	0	0	0	0	0	0	0	0	0	0	0	0	0	0	0	0	0
	↑	GS1	1	0	0	0	0	0	0	0	0	0	0	0	0	0	0	0	0	0	0	0	0	0	0	0
	Darker	GS2	0	1	0	0	0	0	0	0	0	0	0	0	0	0	0	0	0	0	0	0	0	0	0	0
	↑	↓				↓							↓									↓				
	↓	↓				↓							↓									↓				
	Brighter	GS250	1	0	1	1	1	1	1	1	1	1	1	1	1	1	1	1	0	0	0	0	0	0	0	0
	↓	GS251	0	1	1	1	1	1	1	1	1	1	1	1	1	1	1	1	0	0	0	0	0	0	0	0
	Red	GS252	1	1	1	1	1	1	1	1	1	1	1	1	1	1	1	1	0	0	0	0	0	0	0	0
Gray Scale of Green	Black	GS0	0	0	0	0	0	0	0	0	0	0	0	0	0	0	0	0	0	0	0	0	0	0	0	0
	↑	GS1	0	0	0	0	0	0	0	0	0	0	0	0	0	0	0	1	0	0	0	0	0	0	0	0
	Darker	GS2	0	0	0	0	0	0	0	0	0	0	0	0	0	0	0	0	1	0	0	0	0	0	0	0
	↑	↓				↓							↓									↓				
	↓	↓				↓							↓									↓				
	Brighter	GS250	0	0	0	0	0	0	0	0	0	0	0	0	0	0	0	1	0	1	1	1	1	1	1	1
	↓	GS251	0	0	0	0	0	0	0	0	0	0	0	0	0	0	0	0	1	1	1	1	1	1	1	1
	Green	GS252	0	0	0	0	0	0	0	0	0	0	0	0	0	0	0	1	1	1	1	1	1	1	1	1
Gray Scale of Blue	Black	GS0	0	0	0	0	0	0	0	0	0	0	0	0	0	0	0	0	0	0	0	0	0	0	0	0
	↑	GS1	0	0	0	0	0	0	0	0	0	0	0	0	0	0	0	0	0	0	0	0	0	0	0	0
	Darker	GS2	0	0	0	0	0	0	0	0	0	0	0	0	0	0	0	0	0	0	0	0	0	0	0	0
	↑	↓				↓							↓									↓				
	↓	↓				↓							↓									↓				
	Brighter	GS250	0	0	0	0	0	0	0	0	0	0	0	0	0	0	0	0	0	0	0	0	0	0	0	0
	↓	GS251	0	0	0	0	0	0	0	0	0	0	0	0	0	0	0	0	0	0	0	0	0	0	0	0
	Blue	GS252	0	0	0	0	0	0	0	0	0	0	0	0	0	0	0	0	1	1	1	1	1	1	1	1

0 : Low level voltage, 1 : High level voltage.

Each basic color can be displayed in 256 gray scales from 8 bit data signals. According to the combination of total 48 bit data signals, the 16-million-color display can be achieved on the screen.

9. Optical Characteristics

Ta=25 , Vcc =+12V

Parameter		Symbol	Condition	Min.	Typ.	Max.	Unit	Remark
Viewing angle range	Vertical	11	CR 5	60	75	-	Deg.	【Note1,4】
		12		60	75	-	Deg.	
	Horizontal	21, 22		60	75	-	Deg.	
	Vertical	11	CR 10	50	70	-	Deg.	【Note1,4】
		12		40	55	-	Deg.	
		Horizontal		21, 22	50	70	-	
Contrast ratio		CR	=0 °	300	350	-		【Note2,4】
Response Time	Rise	r		-	10	25	mS	【Note3,4】
	Decay	d		-	35	50	mS	
Chromaticity of White		Wx		0.273	0.303	0.333	-	【Note4】
		Wy		0.289	0.319	0.349	-	
Chromaticity of Red		Rx		0.600	0.630	0.660	-	
		Ry		0.312	0.342	0.372	-	
Chromaticity of Green		Gx		0.247	0.277	0.307	-	
		Gy		0.557	0.587	0.617	-	
Chromaticity of Blue		Bx		0.114	0.144	0.174	-	
		By	0.057	0.087	0.117	-		
Luminance of white		YL	180	200	-	cd/m ²	IL=6.0mA rms 【Note4】	
White Uniformity		w	-	-	1.25	-	【Note5】	

* The measurement shall be executed 30 minutes after lighting at rating.

The optical characteristics shall be measured in a dark room or equivalent state with the method shown in Fig.3 below.

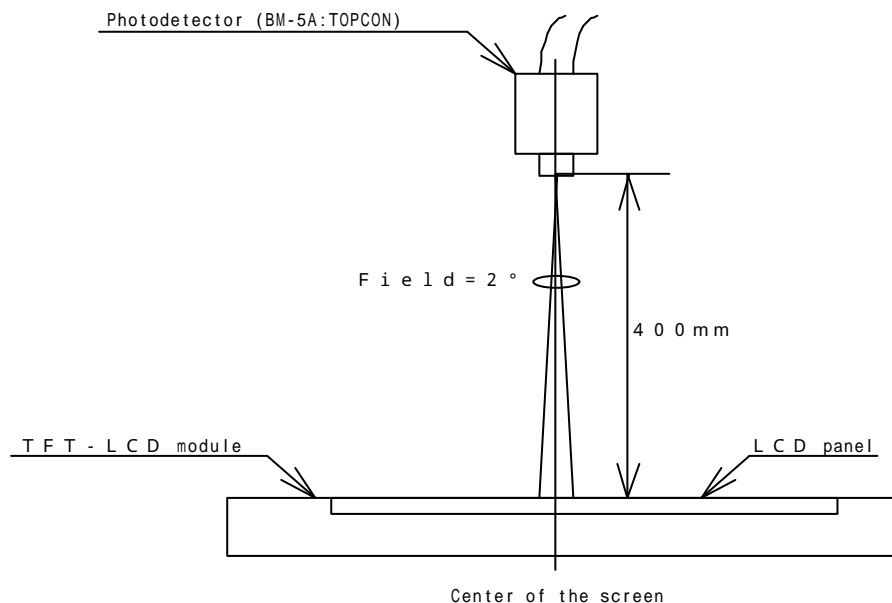
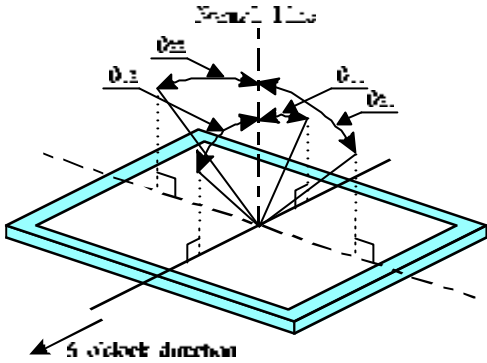

Fig.3 Optical characteristics measurement method

【Note1】 Definitions of viewing angle range:



【Note2】 Definition of contrast ratio:

The contrast ratio is defined as the following .

$$\text{Contrast Ratio (CR)} = \frac{\text{Luminance (brightness) with all pixels white}}{\text{Luminance (brightness) with all pixels black}}$$

【Note3】 Definition of response time:

The response time is defined as the following figure and shall be measured by switching the input signal for "black" and "white" .

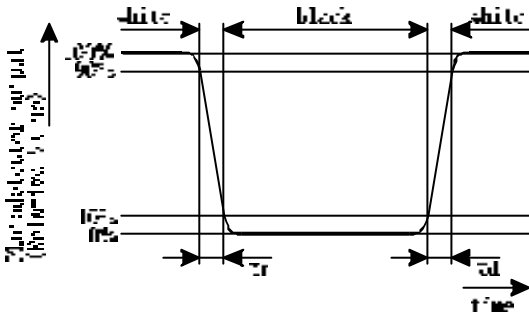

【Note4】 This shall be measured at center of the screen .

【Note5】 Definition of white uniformity:

White uniformity is defined as the following with five measurements (A ~ E) .

$$w = \frac{\text{Maximum Luminance of five points (brightness)}}{\text{Minimum Luminance of five points (brightness)}}$$

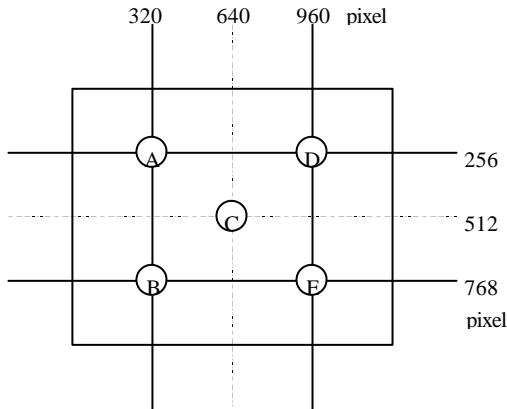

10. Handling Precautions

- a) Be sure to turn off the power supply when inserting or disconnecting the cable.
- b) Be sure to design the cabinet so that the module can be installed without any extra stress such as warp or twist.
- c) Since the front polarize is easily damaged, pay attention not to scratch it.
- d) Since long contact with water may cause discoloration or spots, wipe off water drop immediately.
- e) When the panel surface is soiled, wipe it with absorbent cotton or other soft cloth.
- f) Since the panel is made of glass, it may break or crack if dropped or bumped on hard surface. Handle with care.
- g) Since CMOS LSI is used in this module, take care of static electricity and take the human earth into consideration when handling.
- h) Make sure the four mounting holes of the module are grounded sufficiently. Take electro-magnetic interference (EMI) into consideration.
- i) The module has some printed circuit boards (PCBs) on the back side. Take care to keep them from any stress or pressure when handling or installing the module; otherwise some of electronic parts on the PCBs may be damaged.
- j) Observe all other precautionary requirements in handling components.
- k) When some pressure is added onto the module from rear side constantly, it causes display non-uniformity issue, functional defect, etc. So, please avoid such design.
- l) When handling LCD modules and assembling them into cabinets, please be noted that long-term storage in the environment of oxidization or deoxidization gas and the use of such materials as reagent, solvent, adhesive, resin, etc. which generate these gasses, may cause corrosion and discoloration of the LCD modules.

11. Packing form

- a) Piling number of cartons : Max. 10 cartons
- b) Packing quantity in one carton : 2 modules
- c) Carton size[mm] : 563 (W) × 483 (D) × 136 (H)
- d) Total mass of one carton filled with full modules : Max. 6150 g
- e) Packing form is shown in Fig .2

12. Reliability test items

No.	Test Item	Conditions
1	High temperature storage test	Ta=60 240h
2	Low temperature storage test	Ta=-25 240h
3	High temperature & high humidity operation test	Ta=40 90%RH 240h (No condensation)
4	High temperature operation test	Ta=50 240h (The panel temp. must be less than 60)
5	Low temperature operation test	Ta=0 240h
6	Vibration test (non- operating)	Frequency : 10 ~ 57Hz/Vibration width (one said) : 0.075mm : 58 ~ 500Hz/Gravity : 9.8m/s ² Sweep time : 11minutes Test period : 3 hours (1 hours for each direction X,Y,Z)
7	Shock test (non- operating)	Max, gravity : 490m/s ² Pulse width : 11 ms, sine wave Direction : ± X, ± Y, ± Z once for each direction

【Result Evaluation Criteria】

Under the display quality test conditions with normal operation state, these shall be no change which may affect practical display function.

13. Others

1) Barcode Label

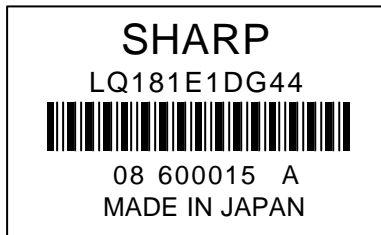

Model No.

Barcode(serial No.)

Serial No.

2

(example) 9 9 3 0 0 0 0 1 A

A production year (the last figures of the Christian Era)

Production month

Production factory

Consecutive number

revision code (First Lot : -)

About production month : 1 ~ 9,X(Oct.),Y(Nov.),Z(Dec.)

2) Packing Label

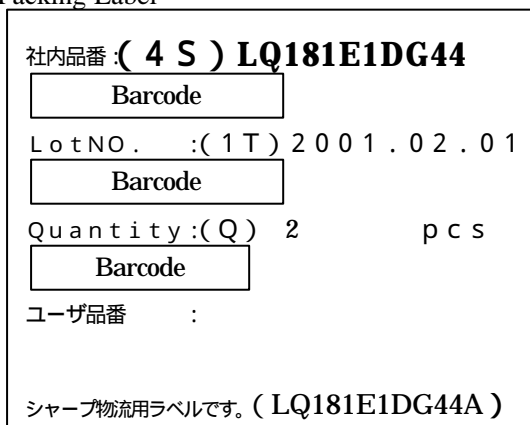

Model No.

Lot No. (Date)

Quantity

User Model No.

Sharp Model No.

2

3) Adjusting volume have been set optimally before shipment, so do not change any adjusted value.

If adjusted value is changed, the specification may not be satisfied.

4) Disassembling the module can cause permanent damage and should be strictly avoided.

5) Please be careful since image retention may occur when a fixed pattern is displayed for a long time.

6) When any question or issue occurs, it shall be solved by mutual discussion.

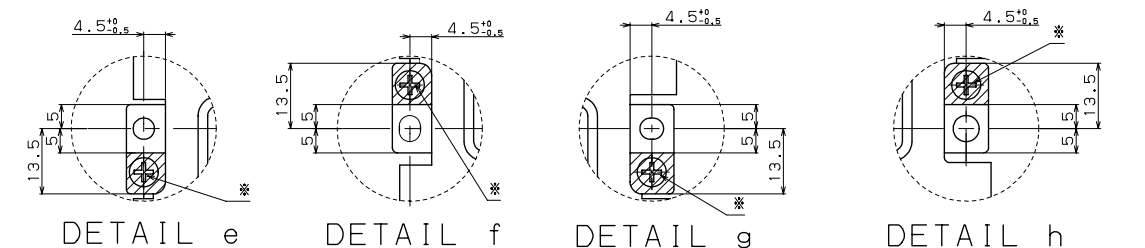
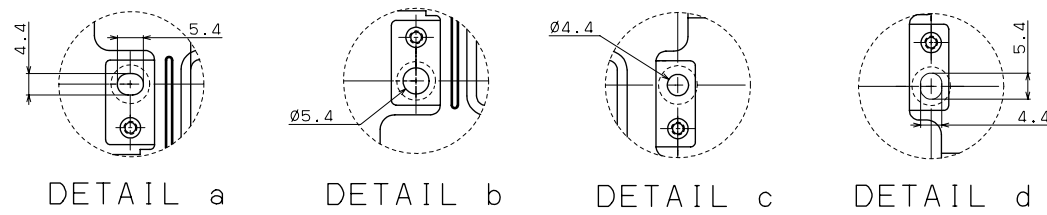
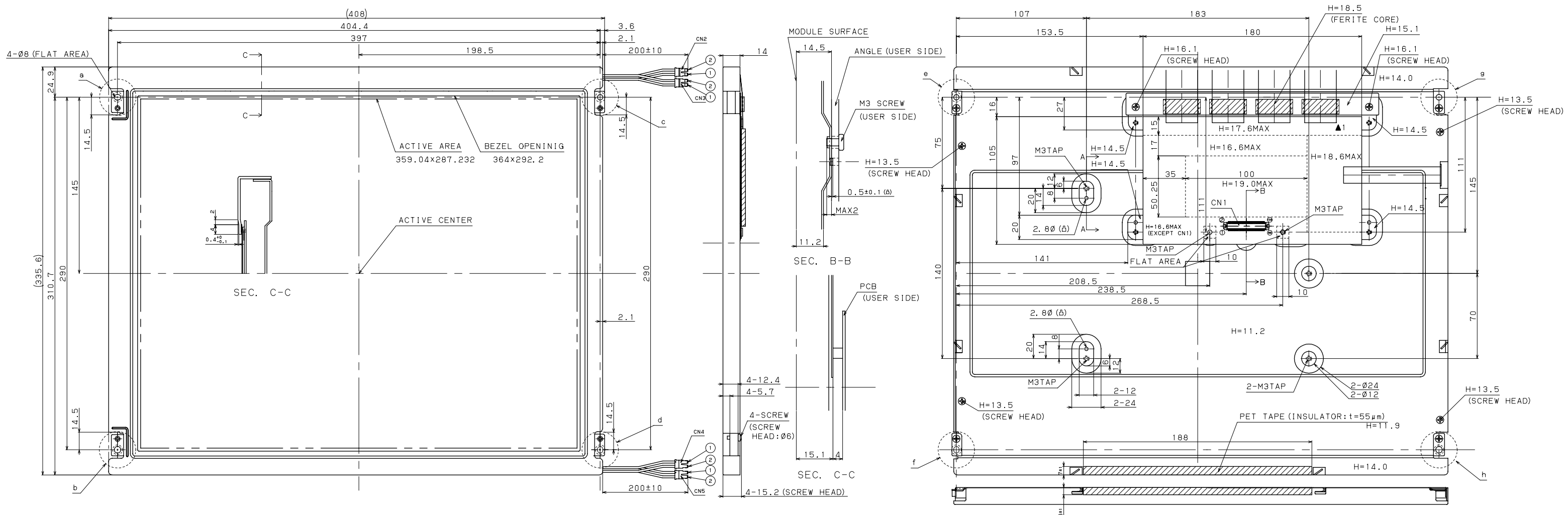

I/F CONNECTOR
CN1: FX10B-100P/10-SV (HIROSE)

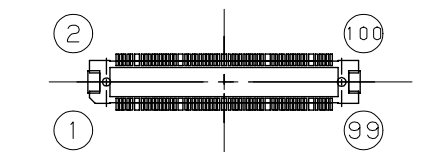

BEZEL/DISPLAY POSITION

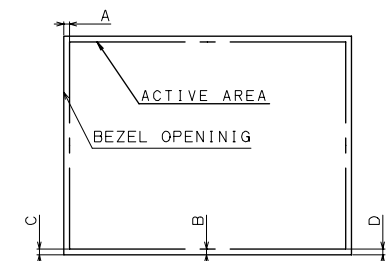

- NOTES)
- 1) UNSPECIFIED TOLERANCE TO BE ±0.5
 - 2) WARP AND FLATING FOR PCB AND CHASSIS ARE EXCLUDED FROM THICKNESS AND DIMENSION OF THE UNIT.

①	High
②	Low

- 1) TOLERANCE X-DIRECTION A: 1.8±0.8
- 2) TOLERANCE Y-DIRECTION A: 1.8±0.8
- 3) OBLIQUITY OF DISPLAY AREA IC-DI<0.8

Fig1. OUTLINE DIMENSIONS (LQ181E1DG44)

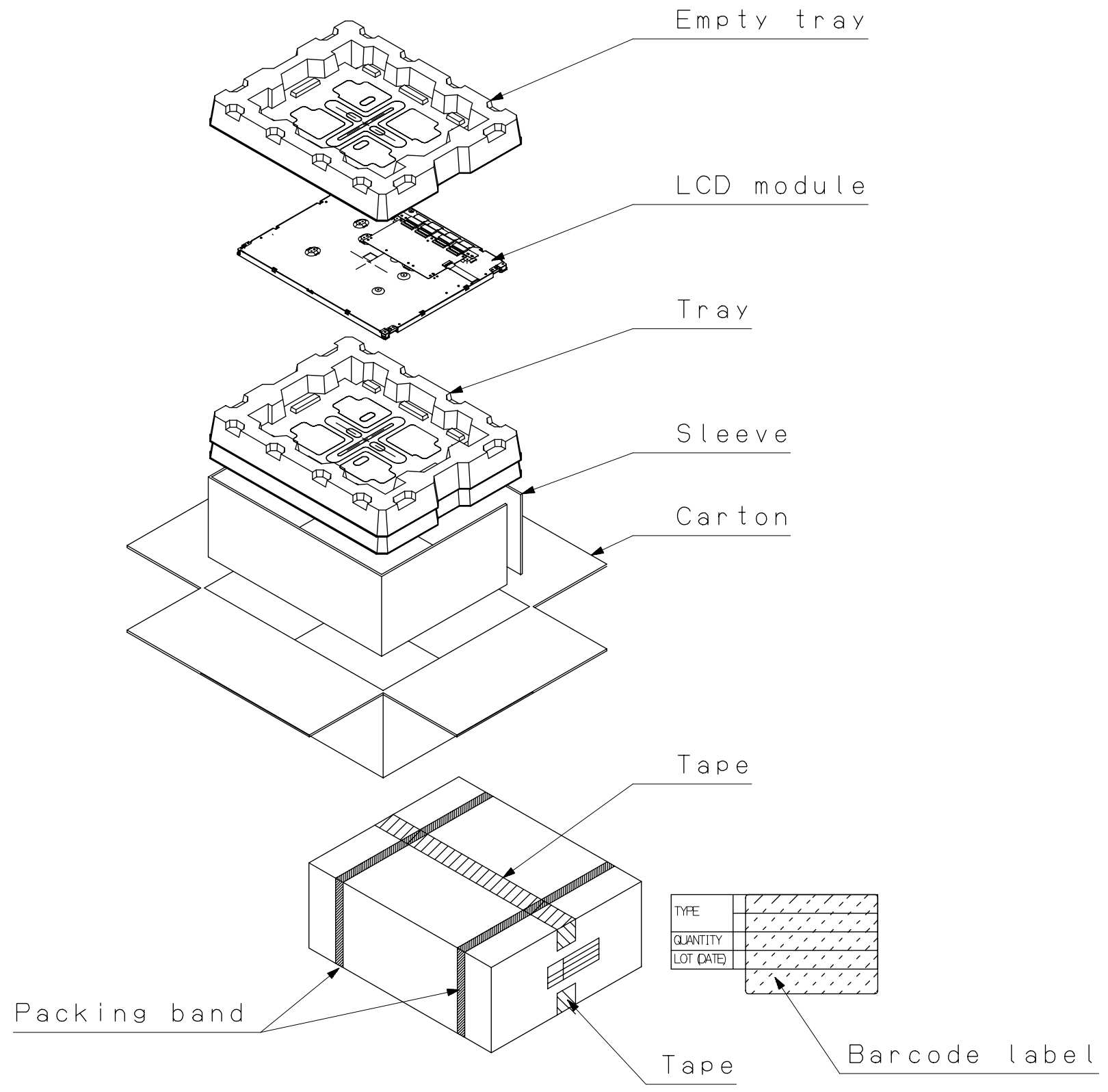

社内品番: (4S) LQ181E1DG44	← ①
[Blank box]	
LotNO. : (1T) 2001.02.10 1	← ②
[Blank box]	
Quantity: (Q) 2 pcs	← ③
[Blank box]	
ユーザー品番 :	← ④
[Blank box]	
シャープ物流用ラベルです。	← ⑤

- ① Model No.
- ② Lot No. (Date)
- ③ Quantity
- ④ User model No.
- ⑤ Sharp model No.

Fig.2 PACKING FORM (LQ181E1DG44)