

| | | |
|-----------------------|--|---|
| PREPARED BY : DATE | <h1>SHARP</h1> <p>TFT LCD DEVELOPMENT GROUP SHARP CORPORATION</p> <h2>SPECIFICATION</h2> | SPEC No. LD-13Y13 |
| | | FILE No. |
| | | ISSUE : Dec.27.2001 |
| APPROVED BY : DATE | | PAGE : 22 pages |
| | | APPLICABLE GROUP TFT Liquid Crystal Display Group |

DEVICE SPECIFICATION
TFT-LCD Module
 MODEL
LQ181E1LW3S

CUSTOMER'S APPROVAL

DATE _____

BY _____

PRESENTED

BY *Makoto Takeda*

M.TAKEDA
 Department General Manager
 Development Engineering Department 2
 TFT Division 2
 TFT LIQUID CRYSTAL DISPLAY GROUP
 SHARP CORPORATION



1. Application

This specification applies to the color 18.1 SXGA TFT-LCD module LQ181E1LW3S.

- These specification sheets are the proprietary product of SHARP CORPORATION ("SHARP") and include materials protected under copyright of SHARP. Do not reproduce or cause any third party to reproduce them in any form or by any means, electronic or mechanical, for any purpose, in whole or in part, without the express written permission of SHARP.
- The device listed in these specification sheets was designed and manufactured for use in OA equipment.
- In case of using the device for applications such as control and safety equipment for transportation (aircraft, trains, automobiles, etc.), rescue and security equipment and various safety related equipment which require higher reliability and safety, take into consideration that appropriate measures such as fail-safe functions and redundant system design should be taken.
- Do not use the device for equipment that requires an extreme level of reliability, such as aerospace applications, telecommunication equipment (trunk lines), nuclear power control equipment and medical or other equipment for life support.
- SHARP assumes no responsibility for any damage resulting from the use of the device which does not comply with the instructions and the precautions specified in these specification sheets.
- Contact and consult with a SHARP sales representative for any questions about this device.

2. Overview

This module is a color active matrix LCD module incorporating amorphous silicon TFT (Thin Film Transistor). It is composed of a color TFT-LCD panel, driver ICs, control circuit, power supply circuit and a back light unit. Graphics and texts can be displayed on a 1280 × 3 × 1024 dots panel with about 16 million colors (8 bit) by using LVDS (Low Voltage Differential Signaling) to interface and supplying +12 DC supply voltages for TFT-LCD panel driving and supply voltage for backlight.

It is a wide viewing-angle-module using SHARP original technology.

Backlight-driving DC/AC inverter is not built in this module.

3. Mechanical Specifications

| Parameter | Specifications | Unit |
|----------------------------|--------------------------------|-------|
| Display size | 46 (Diagonal) | cm |
| | 18.1 (Diagonal) | Inch |
| Active area | 359.0 (H)×287.2 (V) | mm |
| Pixel format | 1280 (H)×1024 (V) | Pixel |
| | (1 pixel=R+G+B dots) | |
| Pixel pitch | 0.2805 (H) × 0.2805 (V) | mm |
| Pixel configuration | R,G,B vertical stripe | |
| Display mode | Normally Black | |
| Unit outline dimensions *1 | 389 (W)×317.2 (H)×27.5(D) | mm |
| Mass | MAX 3.5 | kg |
| Surface treatment | Anti-glare and hard-coating 2H | |

*1.Note: excluding back light cables.

The thickness of module (D) doesn't contain the projection.

Outline dimensions are shown in Fig.1.

4. Input Terminals

4-1. TFT-LCD panel driving

CN1 (Interface signals and +12VDC power supply)

Using connector : FI-SE30P-HF (Japan Aviation Electronics Ind.,Ltd.)

Mating connector : FI-S30S (Japan Aviation Electronics Ind.,Ltd.)

| Pin No. | Symbol | Function | Remark |
|---------|-----------|---|--------------------|
| 1 | Vcc | +12V Power Supply | |
| 2 | Vcc | +12V Power Supply | |
| 3 | Vcc | +12V Power Supply | |
| 4 | GND | GND | |
| 5 | GND | GND | |
| 6 | GND | GND | |
| 7 | SELLVDS | Select LVDS data order 【Note2】 | 3.3V C-MOS Pull Up |
| 8 | NC | NC | |
| 9 | GND | GND | |
| 10 | RxBIN3+ | Positive (+) LVDS differential data input (B port) | LVDS |
| 11 | RxBIN3- | Negative (-) LVDS differential data input (B port) | LVDS |
| 12 | RxBCLKIN+ | Positive (+) LVDS differential clock input (B port) | LVDS |
| 13 | RxBCLKIN- | Negative (-) LVDS differential clock input (B port) | LVDS |
| 14 | RxBIN2+ | Positive (+) LVDS differential data input (B port) | LVDS |
| 15 | RxBIN2- | Negative (-) LVDS differential data input (B port) | LVDS |
| 16 | RxBIN1+ | Positive (+) LVDS differential data input (B port) | LVDS |
| 17 | RxBIN1- | Negative (-) LVDS differential data input (B port) | LVDS |
| 18 | RxBIN0+ | Positive (+) LVDS differential data input (B port) | LVDS |
| 19 | RxBIN0- | Negative (-) LVDS differential data input (B port) | LVDS |
| 20 | RxAIN3+ | Positive (+) LVDS differential data input (A port) | LVDS |
| 21 | RxAIN3- | Negative (-) LVDS differential data input (A port) | LVDS |
| 22 | RxACLKIN+ | Positive (+) LVDS differential clock input (A port) | LVDS |
| 23 | RxACLKIN- | Negative (-) LVDS differential clock input (A port) | LVDS |
| 24 | RxAIN2+ | Positive (+) LVDS differential data input (A port) | LVDS |
| 25 | RxAIN2- | Negative (-) LVDS differential data input (A port) | LVDS |
| 26 | RxAIN1+ | Positive (+) LVDS differential data input (A port) | LVDS |
| 27 | RxAIN1- | Negative (-) LVDS differential data input (A port) | LVDS |
| 28 | RxAIN0+ | Positive (+) LVDS differential data input (A port) | LVDS |
| 29 | RxAIN0- | Negative (-) LVDS differential data input (A port) | LVDS |
| 30 | GND | GND | |

【Note2】SELLVDS(Thine:THC63LVDM83A)

| Transmitter | | SELLVDS | |
|-------------|------|---------|------------------|
| Pin No | Data | =L(GND) | =H(3.3V) or Open |
| 51 | TA0 | R0(LSB) | R2 |
| 52 | TA1 | R1 | R3 |
| 54 | TA2 | R2 | R4 |
| 55 | TA3 | R3 | R5 |
| 56 | TA4 | R4 | R6 |
| 3 | TA5 | R5 | R7(MSB) |
| 4 | TA6 | G0(LSB) | G2 |
| 6 | TB0 | G1 | G3 |
| 7 | TB1 | G2 | G4 |
| 11 | TB2 | G3 | G5 |
| 12 | TB3 | G4 | G6 |
| 14 | TB4 | G5 | G7(MSB) |
| 15 | TB5 | B0(LSB) | B2 |
| 19 | TB6 | B1 | B3 |
| 20 | TC0 | B2 | B4 |
| 22 | TC1 | B3 | B5 |
| 23 | TC2 | B4 | B6 |
| 24 | TC3 | B5 | B7(MSB) |
| 27 | TC4 | NC | NC |
| 28 | TC5 | (RSV1) | (RSV1) |
| 30 | TC6 | DE | DE |
| 50 | TD0 | R6 | R0(LSB) |
| 2 | TD1 | R7(MSB) | R1 |
| 8 | TD2 | G6 | G0(LSB) |
| 10 | TD3 | G7(MSB) | G1 |
| 16 | TD4 | B6 | B0(LSB) |
| 18 | TD5 | B7(MSB) | B1 |
| 25 | TD6 | (NA) | (NA) |

4-2 Interface block diagram

Using receiver : Contained in a control IC.

Corresponding Transmitter : THC63LVDM83A(THine electronics),DS90C383,DS90C383A(National semiconductor)

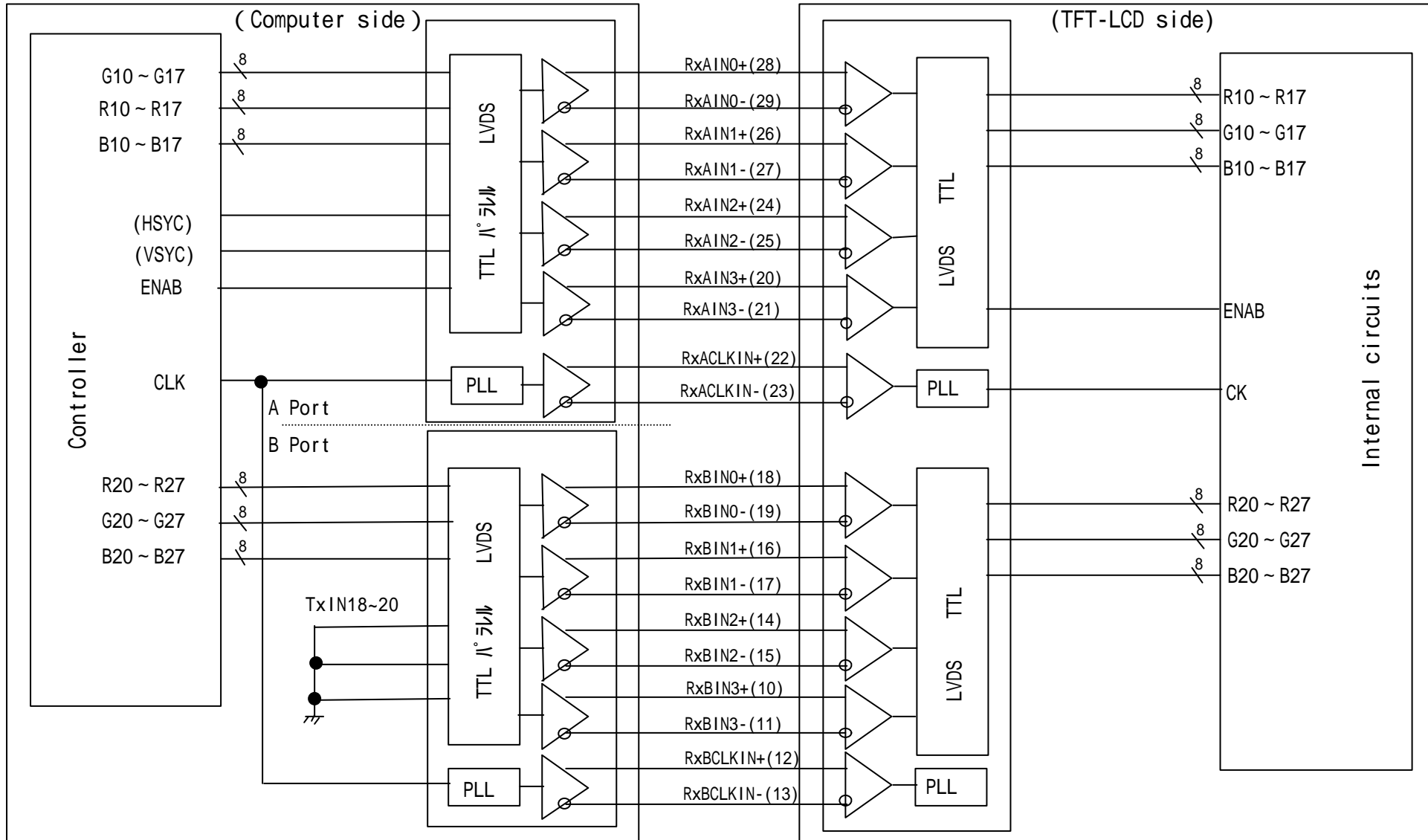
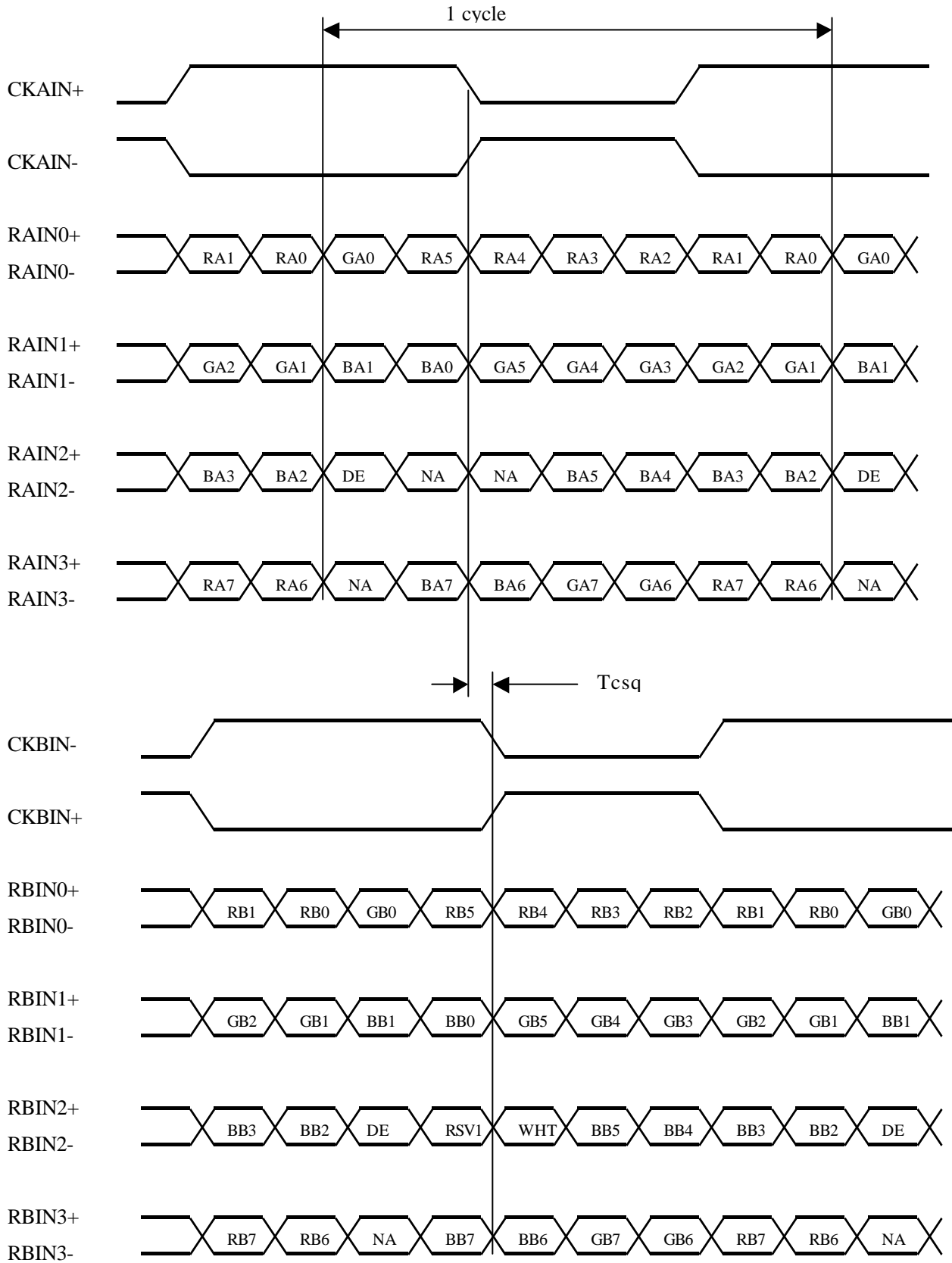

Fig.2 Interface block diagram

SELLVDS= Low(GND)



DE: Display Enable

RSV1: Reserve (Fixed GND)

NA: Not Available

SELLVDS= High(3.3V) or Open

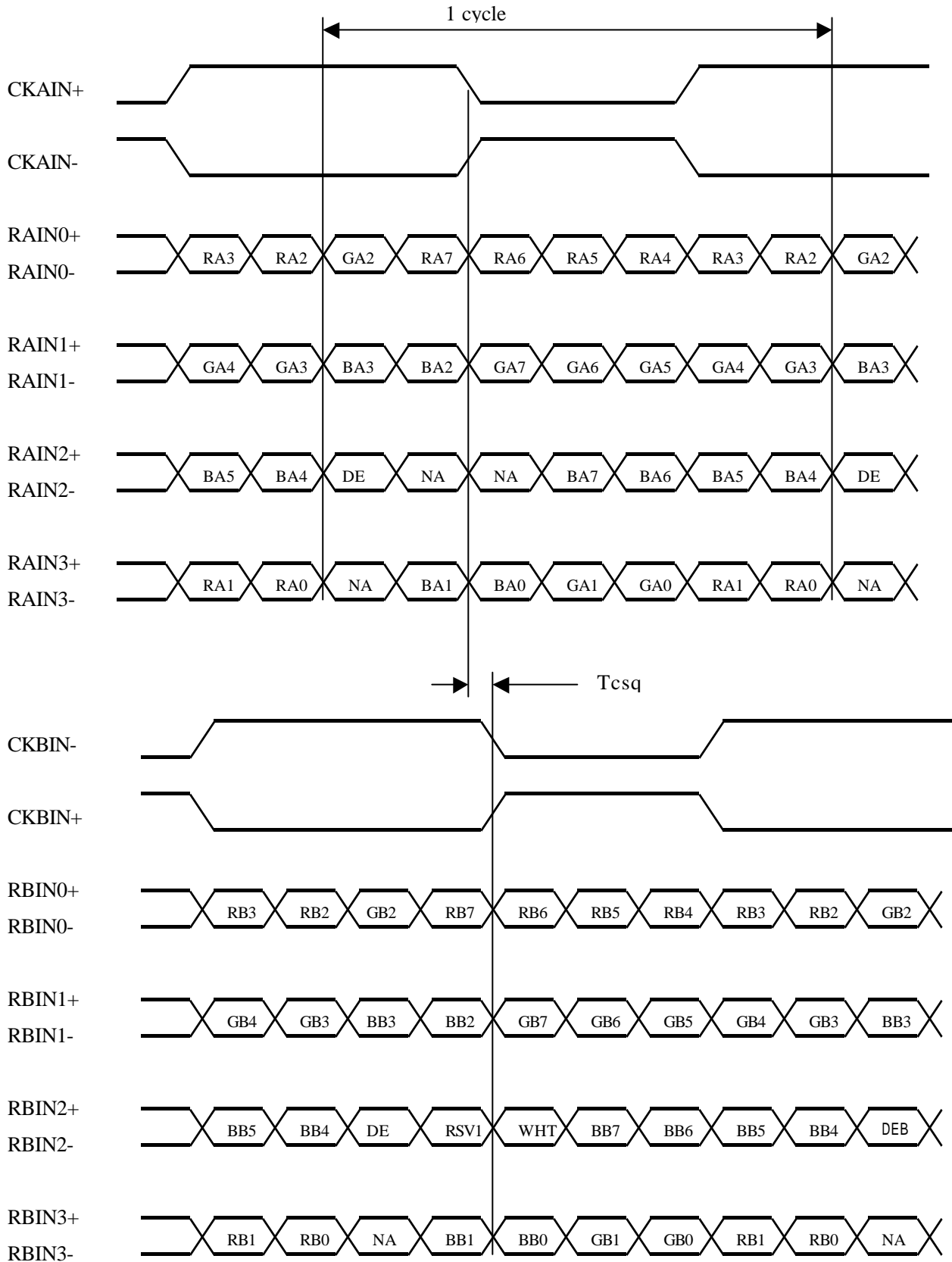

DE: Display Enable

RSV1: Reserve (Fixed GND)

NA: Not Available

4-2. Back light driving

CN 2, 3

The module-side connector : BHSR-02VS-1 (JST)

The user-side connector : SM02B-BHSS-1-TB (JST)

| Pin no. | Symbol | I/O | Function |
|---------|------------|-----|---|
| 1 | V_{HIGH} | I | Power supply for lamp (High voltage side) |
| 2 | V_{LOW} | I | Power supply for lamp (Low voltage side) |

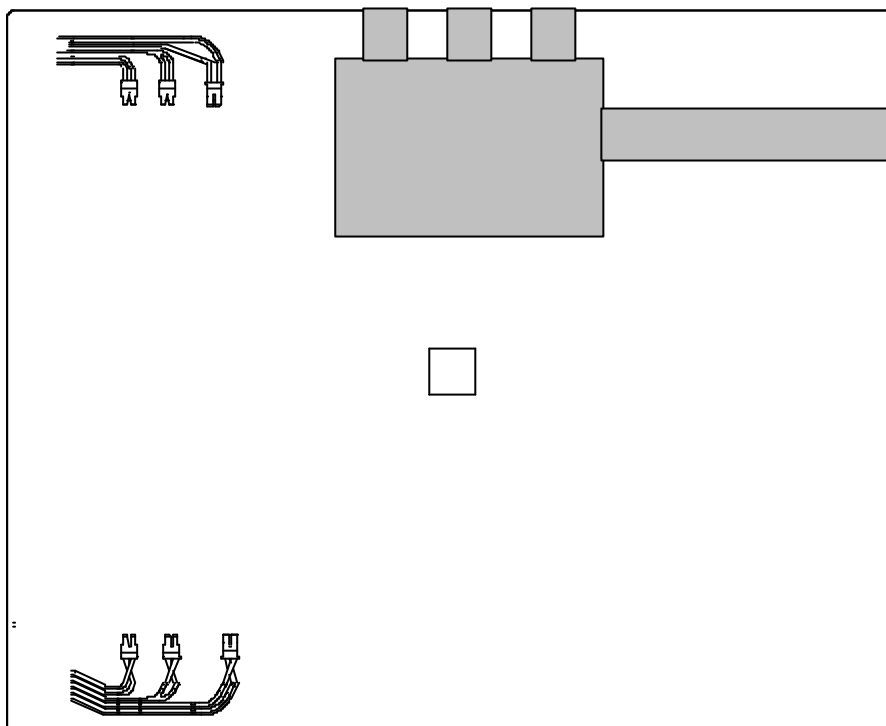

5. Absolute Maximum Ratings

5-1. Module

| Parameter | Symbol | Condition | Ratings | Unit | Remark |
|---------------------------------|--------|-----------|-----------|------|---------|
| Storage temperature | Tstg | - | -25 ~ +60 | | 【Note1】 |
| Operating temperature (Ambient) | Topa | - | 0 ~ +50 | | |

【Note1】 Humidity : 95%RH Max. ($T_a \leq 40$)Maximum wet-bulb temperature at 39 or less. ($T_a > 40$)

No condensation.

5-2. TFT-LCD panel driving

| Parameter | Symbol | Condition | Ratings | Unit | Remark |
|-----------------------|--------|-----------|-----------|------|--------|
| +12.0V supply voltage | Vcc | $T_a=25$ | 0 ~ +14.0 | V | |

6. Electrical Characteristics

6-1. TFT-LCD panel driving

Ta=25

| Parameter | | Symbol | Min. | Typ. | Max. | Unit | Remark |
|----------------------------------|---------------------|-----------------|-------|-------|-------|-------|---------------------|
| Vcc | Supply voltage | Vcc | +11.4 | +12.0 | +12.6 | V | 【Note1】 |
| | Current dissipation | Icc | - | 560 | 1100 | mA | 【Note2】 |
| Permissible input ripple voltage | | V _{RF} | - | - | 100 | mVp-p | |
| Input current (Low) | | I _{IL} | - | - | 10 | μA | V _I =GND |
| Input current (High) | | I _{IH} | - | - | 10 | μA | V _I =Vcc |

【Note1】

1) On-off sequences of Vcc and data

- 0 < t1 ≤ 60ms
- 0 < t2 ≤ 10ms
- 0 ≤ t3 ≤ 1s
- t4 ≥ 100ms

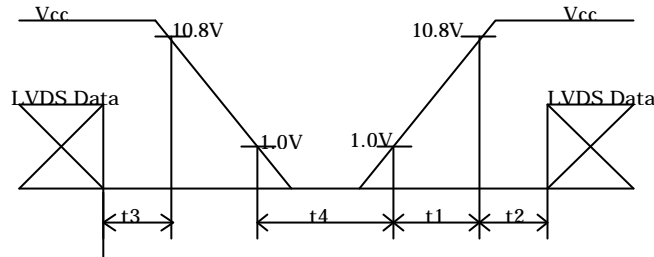

2) Dip conditions for supply voltage

V_{min}=11.4V, V_t=9.6V

- i) V_t ≤ Vcc < V_{min}
t_d ≤ 20ms
- ii) Vcc < V_t

This case is described below *1.

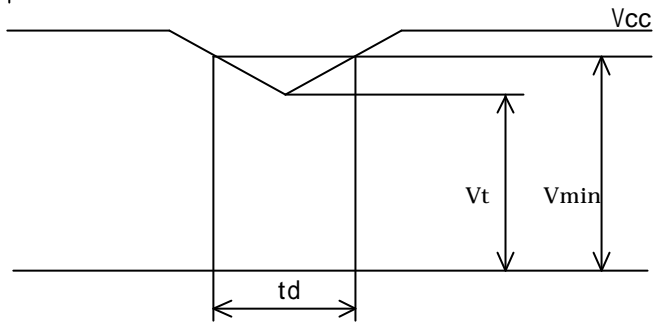

*1 The LCD module shuts down when Vcc < V_t

It should also follow the 1) on-off sequence of Vcc and data.

【Note2】

1) Typical current situation : 16-gray-bar pattern

Vcc=+12.0V

Gray scale : GS(16N) N=0 ~ 15

The explanation of each gray scale ,GS(16n), is described below section 8.

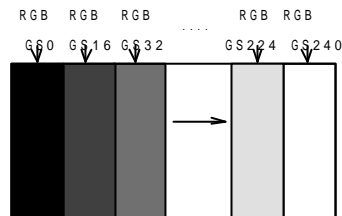

2) Maximum current situation :

The dots described the following figure(left) are displayed the gray scale described the following figure(right).

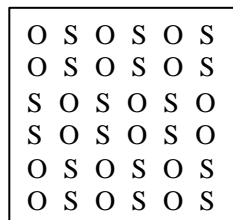
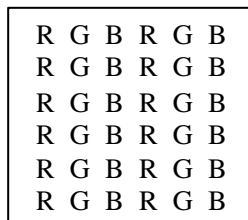

O = V0 gray scale
S = V255 gray scale

The voltage correspond one of the 256 gray scale.

6-2. Back light driving

The back light system is an edge-lighting type with six CCFTs (Cold Cathode Fluorescent Tube). The characteristics of the lamp are shown in the following table. The value mentioned below is at the case of one CCFT.

CCFT Model Name : MBT26B19RX376NRBU(HARISON TOSHIBA LIGHTING Corp.)

| Parameter | Symbol | Min. | Typ. | Max. | Unit | Remark |
|------------------------|--------|-------|------|------|-------|---------------|
| Lamp current range | I_L | 2.5 | 6.0 | 7.0 | mArms | 【Note1】 |
| Lamp voltage | V_L | - | 715 | - | Vrms | Ta=25 |
| Lamp power consumption | P_L | - | 4.3 | - | W | 【Note2】 |
| Lamp frequency | F_L | 35 | 60 | 70 | KHz | 【Note3】 |
| Kick-off voltage | V_s | - | - | 1300 | Vrms | Ta=25 【Note4】 |
| | | - | - | 1500 | Vrms | Ta=0 【Note4】 |
| Lamp life time | T_L | 50000 | - | - | hour | 【Note5】 |

【Note1】 A lamp can be light in the range of lamp current shown above.35~70

Maximum rating for current is measured by high frequency current measurement equipment connected to V_{LOW} at circuit showed below. (Note : To keep enough kick-off voltage and necessary steady voltage for CCFT.)

Lamp frequency: 35~70KHz Ambient temperature: 0 ~ 50

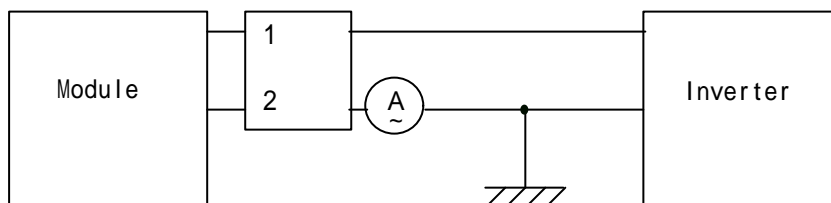

【Note2】 Referential data per one CCFT by calculation ($I_L \times V_L$).

The data don't include loss at inverter.

【Note3】 Lamp frequency may produce interference with horizontal synchronous frequency, and this may cause beat on the display. Therefore lamp frequency shall be detached as much as possible from the horizontal synchronous frequency and from the harmonics of horizontal synchronous to avoid interference.

【Note4】 Kick-off voltage value is described as the index in the state of lamp only.

The kick-off voltage is estimated to be risen up as approx. +200V in the state of module only, and the further rise up can be seen according to the assembling status of user cabinet.

Please set the kick-off voltage of inverter to avoid the lighting failures in the state of operation. Please design the inverter so that its open output voltage can be connected for more than 1 second to startup. Otherwise, the lamp may not be turned on. But, please set as 100ms when the ambient luminance around the lamp is more than 1lux.

【Note5】 Lamp life time is defined as the time when either 1 or 2 occurs in the continuous operation under the condition of Ta=25 and $I_L=6.0$ mArms.

1. Brightness becomes 50% of the original value under standard condition.
2. Kick-off voltage at Ta=0 exceeds maximum value, 1500 Vrms.

《Note》 The performance of the back light, for example life time or brightness, is much influenced by the characteristics of the DC-AC inverter for the lamp. When you design or order the inverter, please make sure that a poor lighting caused by the mismatch of the back light and the inverter (miss-lighting, flicker, etc.) never occurs. When you confirm it, the module should be operated in the same condition as it is installed in your instrument.

7. Timing characteristics of input signals

7-1. 2pixel mode timing characteristics

Timing diagrams of input signal are shown in Fig.3.

| Parameter | | Symbol | Min. | Typ. | Max. | Unit | Remark |
|------------------------|--------------------------|-----------|------|------|------|---------|---------|
| Clock | Frequency | $1/T_c$ | 34 | 45 | 67.5 | MHz | 【Note1】 |
| | Skew | T_{csq} | -1 | 0 | 1 | clock | |
| Data enable signal | Horizontal period | TH | 668 | 848 | 928 | clock | |
| | | | 12.5 | 15 | - | μs | |
| | Horizontal period (High) | THd | 640 | 640 | 640 | clock | |
| | Vertical period | TV | 1026 | 1066 | 1080 | line | 【Note2】 |
| Vertical period (High) | TVd | 1024 | 1024 | 1024 | line | | |

【Note1】 Two pixel-data are sampled at the same time.

【Note2】 In case of using the long vertical period, the deterioration of display quality, flicker etc. may occur.
There should be integral horizontal period per one vertical period.

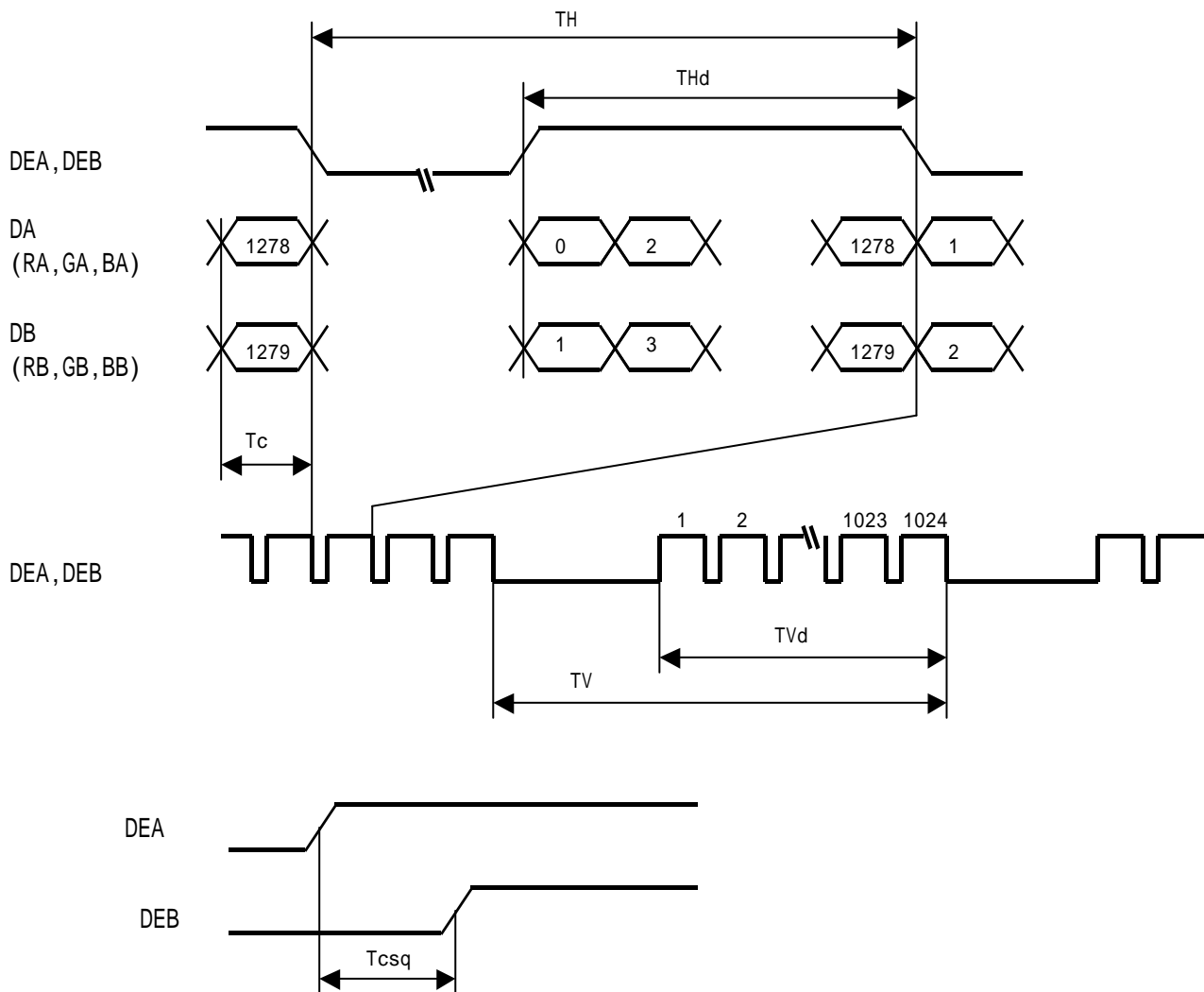
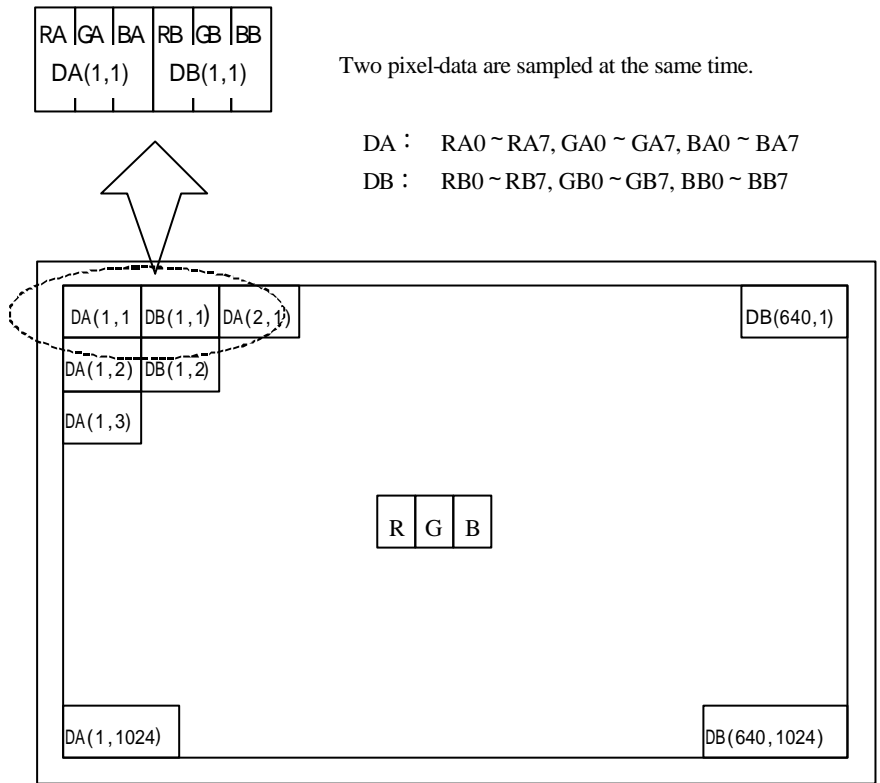

Fig.3 Timing diagrams of input signal

7-2 Input Data Signals and Display Position on the screen

Graphics and texts can be displayed on a $1280 \times 3 \times 1024$ dots panel with 16M colors by supplying 48 bit data signal (8bit/color [256 gray scale] $\times 3 \times 2$ pixels).



Display position of input data(H,V)

8. Input Signals, Basic Display Colors and Gray Scale of Each Color

| Colors & Gray scale | Data signal | | | | | | | | | | | | | | | | | | | | | | | | | | | |
|------------------------|---------------|-------|-----|-----|-----|-----|-----|-----|-----|-----|-----|-----|-----|-----|-----|-----|-----|-----|-----|-----|-----|-----|-----|-----|-----|---|---|--|
| | Gray Scale | RA0 | RA1 | RA2 | RA3 | RA4 | RA5 | RA6 | RA7 | GA0 | GA1 | GA2 | GA3 | GA4 | GA5 | GA6 | GA7 | BA0 | BA1 | BA2 | BA3 | BA4 | BA5 | BA6 | BA7 | | | |
| | | RB0 | RB1 | RB2 | RB3 | RB4 | RB5 | RB6 | RB7 | GB0 | GB1 | GB2 | GB3 | GB4 | GB5 | GB6 | GB7 | BB0 | BB1 | BB2 | BB3 | BB4 | BB5 | BB6 | BB7 | | | |
| Basic Color | Black | - | 0 | 0 | 0 | 0 | 0 | 0 | 0 | 0 | 0 | 0 | 0 | 0 | 0 | 0 | 0 | 0 | 0 | 0 | 0 | 0 | 0 | 0 | 0 | 0 | 0 | |
| | Blue | - | 0 | 0 | 0 | 0 | 0 | 0 | 0 | 0 | 0 | 0 | 0 | 0 | 0 | 0 | 0 | 1 | 1 | 1 | 1 | 1 | 1 | 1 | 1 | 1 | 1 | |
| | Green | - | 0 | 0 | 0 | 0 | 0 | 0 | 0 | 0 | 1 | 1 | 1 | 1 | 1 | 1 | 1 | 0 | 0 | 0 | 0 | 0 | 0 | 0 | 0 | 0 | 0 | |
| | Cyan | - | 0 | 0 | 0 | 0 | 0 | 0 | 0 | 0 | 1 | 1 | 1 | 1 | 1 | 1 | 1 | 1 | 1 | 1 | 1 | 1 | 1 | 1 | 1 | 1 | 1 | |
| | Red | - | 1 | 1 | 1 | 1 | 1 | 1 | 1 | 1 | 0 | 0 | 0 | 0 | 0 | 0 | 0 | 0 | 0 | 0 | 0 | 0 | 0 | 0 | 0 | 0 | 0 | |
| | Magenta | - | 1 | 1 | 1 | 1 | 1 | 1 | 1 | 1 | 0 | 0 | 0 | 0 | 0 | 0 | 0 | 1 | 1 | 1 | 1 | 1 | 1 | 1 | 1 | 1 | 1 | |
| | Yellow | - | 1 | 1 | 1 | 1 | 1 | 1 | 1 | 1 | 1 | 1 | 1 | 1 | 1 | 1 | 1 | 0 | 0 | 0 | 0 | 0 | 0 | 0 | 0 | 0 | 0 | |
| | White | - | 1 | 1 | 1 | 1 | 1 | 1 | 1 | 1 | 1 | 1 | 1 | 1 | 1 | 1 | 1 | 1 | 1 | 1 | 1 | 1 | 1 | 1 | 1 | 1 | 1 | |
| Gray Scale of Red | Black | GS0 | 0 | 0 | 0 | 0 | 0 | 0 | 0 | 0 | 0 | 0 | 0 | 0 | 0 | 0 | 0 | 0 | 0 | 0 | 0 | 0 | 0 | 0 | 0 | 0 | 0 | |
| | ↑ | GS1 | 1 | 0 | 0 | 0 | 0 | 0 | 0 | 0 | 0 | 0 | 0 | 0 | 0 | 0 | 0 | 0 | 0 | 0 | 0 | 0 | 0 | 0 | 0 | 0 | 0 | |
| | Darker | GS2 | 0 | 1 | 0 | 0 | 0 | 0 | 0 | 0 | 0 | 0 | 0 | 0 | 0 | 0 | 0 | 0 | 0 | 0 | 0 | 0 | 0 | 0 | 0 | 0 | 0 | |
| | ↑ | ↓ | | | | | ↓ | | | | | | ↓ | | | | | | | | | | ↓ | | | | | |
| | ↓ | ↓ | | | | | ↓ | | | | | | ↓ | | | | | | | | | | ↓ | | | | | |
| | Brighter | GS250 | 1 | 0 | 1 | 1 | 1 | 1 | 1 | 1 | 0 | 0 | 0 | 0 | 0 | 0 | 0 | 0 | 0 | 0 | 0 | 0 | 0 | 0 | 0 | 0 | 0 | |
| | ↓ | GS251 | 0 | 1 | 1 | 1 | 1 | 1 | 1 | 1 | 0 | 0 | 0 | 0 | 0 | 0 | 0 | 0 | 0 | 0 | 0 | 0 | 0 | 0 | 0 | 0 | 0 | |
| | Red | GS252 | 1 | 1 | 1 | 1 | 1 | 1 | 1 | 1 | 0 | 0 | 0 | 0 | 0 | 0 | 0 | 0 | 0 | 0 | 0 | 0 | 0 | 0 | 0 | 0 | 0 | |
| Gray Scale of Green | Black | GS0 | 0 | 0 | 0 | 0 | 0 | 0 | 0 | 0 | 0 | 0 | 0 | 0 | 0 | 0 | 0 | 0 | 0 | 0 | 0 | 0 | 0 | 0 | 0 | 0 | 0 | |
| | ↑ | GS1 | 0 | 0 | 0 | 0 | 0 | 0 | 0 | 0 | 1 | 0 | 0 | 0 | 0 | 0 | 0 | 0 | 0 | 0 | 0 | 0 | 0 | 0 | 0 | 0 | 0 | |
| | Darker | GS2 | 0 | 0 | 0 | 0 | 0 | 0 | 0 | 0 | 0 | 1 | 0 | 0 | 0 | 0 | 0 | 0 | 0 | 0 | 0 | 0 | 0 | 0 | 0 | 0 | 0 | |
| | ↑ | ↓ | | | | | ↓ | | | | | | ↓ | | | | | | | | | | ↓ | | | | | |
| | ↓ | ↓ | | | | | ↓ | | | | | | ↓ | | | | | | | | | | ↓ | | | | | |
| | Brighter | GS250 | 0 | 0 | 0 | 0 | 0 | 0 | 0 | 0 | 1 | 0 | 1 | 1 | 1 | 1 | 1 | 0 | 0 | 0 | 0 | 0 | 0 | 0 | 0 | 0 | 0 | |
| | ↓ | GS251 | 0 | 0 | 0 | 0 | 0 | 0 | 0 | 0 | 0 | 1 | 1 | 1 | 1 | 1 | 1 | 0 | 0 | 0 | 0 | 0 | 0 | 0 | 0 | 0 | 0 | |
| | Green | GS252 | 0 | 0 | 0 | 0 | 0 | 0 | 0 | 0 | 1 | 1 | 1 | 1 | 1 | 1 | 1 | 0 | 0 | 0 | 0 | 0 | 0 | 0 | 0 | 0 | 0 | |
| Gray Scale of Blue | Black | GS0 | 0 | 0 | 0 | 0 | 0 | 0 | 0 | 0 | 0 | 0 | 0 | 0 | 0 | 0 | 0 | 0 | 0 | 0 | 0 | 0 | 0 | 0 | 0 | 0 | 0 | |
| | ↑ | GS1 | 0 | 0 | 0 | 0 | 0 | 0 | 0 | 0 | 0 | 0 | 0 | 0 | 0 | 0 | 0 | 1 | 0 | 0 | 0 | 0 | 0 | 0 | 0 | 0 | 0 | |
| | Darker | GS2 | 0 | 0 | 0 | 0 | 0 | 0 | 0 | 0 | 0 | 0 | 0 | 0 | 0 | 0 | 0 | 0 | 1 | 0 | 0 | 0 | 0 | 0 | 0 | 0 | 0 | |
| | ↑ | ↓ | | | | | ↓ | | | | | | ↓ | | | | | | | | | | ↓ | | | | | |
| | ↓ | ↓ | | | | | ↓ | | | | | | ↓ | | | | | | | | | | ↓ | | | | | |
| | Brighter | GS250 | 0 | 0 | 0 | 0 | 0 | 0 | 0 | 0 | 0 | 0 | 0 | 0 | 0 | 0 | 0 | 1 | 0 | 1 | 1 | 1 | 1 | 1 | 1 | 1 | 1 | |
| | ↓ | GS251 | 0 | 0 | 0 | 0 | 0 | 0 | 0 | 0 | 0 | 0 | 0 | 0 | 0 | 0 | 0 | 0 | 1 | 1 | 1 | 1 | 1 | 1 | 1 | 1 | 1 | |
| | Blue | GS252 | 0 | 0 | 0 | 0 | 0 | 0 | 0 | 0 | 0 | 0 | 0 | 0 | 0 | 0 | 0 | 1 | 1 | 1 | 1 | 1 | 1 | 1 | 1 | 1 | 1 | |

0 : Low level voltage, 1 : High level voltage.

Each basic color can be displayed in 256 gray scales from 8 bit data signals. According to the combination of total 48 bit data signals, the 16-million-color display can be achieved on the screen.

9. Optical Characteristics

Ta=25 , Vcc=+12V

| Parameter | | Symbol | Condition | Min. | Typ. | Max. | Unit | Remark |
|--------------------------|------------|----------------------------|------------------|-------|-------|-------------------|-------------------------------------|-----------|
| Viewing Angle range | Vertical | θ_{11} | CR=10 | 70 | 85 | - | Deg. | 【Note1,4】 |
| | | θ_{12} | | 70 | 85 | - | Deg. | |
| | Horizontal | θ_{21}, θ_{22} | | 70 | 85 | - | Deg. | |
| Contrast ratio | | CR | $\theta=0^\circ$ | - | 400 | - | | 【Note2,4】 |
| Response Time | Rise | τ_d | | - | 20 | - | ms | 【Note3,4】 |
| | Decay | τ_r | | - | 5 | - | ms | |
| Chromaticity of white | | W_x | | 0.278 | 0.308 | 0.333 | - | 【Note4】 |
| | | W_y | | 0.290 | 0.320 | 0.350 | - | |
| Chromaticity of red | | R_x | | 0.612 | 0.642 | 0.682 | - | |
| | | R_y | | 0.309 | 0.339 | 0.369 | - | |
| Chromaticity of green | | G_x | | 0.260 | 0.290 | 0.320 | - | |
| | | G_y | | 0.578 | 0.608 | 0.638 | - | |
| Chromaticity of blue | | B_x | | 0.113 | 0.143 | 0.173 | - | |
| | | B_y | 0.055 | 0.085 | 0.115 | - | | |
| Luminance of white | | Y_L | 180 | 220 | - | cd/m ² | IL=6.0mA rms FL=60KHz 【Note4】 | |
| White Uniformity | | w | - | - | 1.25 | - | 【Note5】 | |

* The measurement shall be executed 30 minutes after lighting at rating.

The optical characteristics shall be measured in the state of module only in a dark room or equivalent state with the method shown in Fig.4 below.

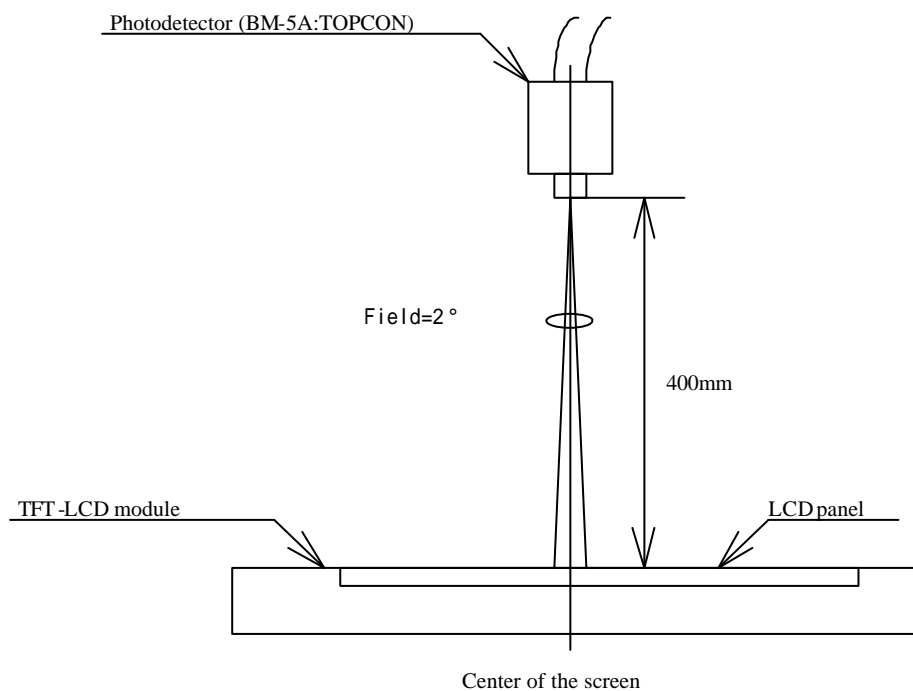
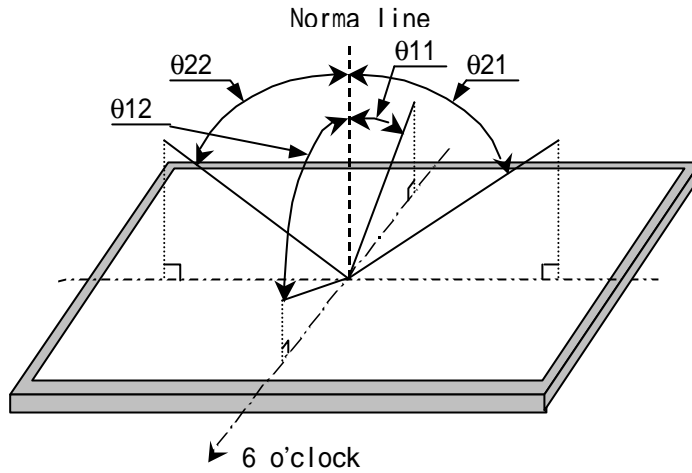

Fig.4 Optical characteristics measurement method

【Note1】 Definitions of viewing angle range:



【Note2】 Definition of contrast ratio:

The contrast ratio is defined as the following.

$$\text{Contrast Ratio (CR)} = \frac{\text{Luminance (brightness) with all pixels white}}{\text{Luminance (brightness) with all pixels black}}$$

【Note3】 Definition of response time:

The response time is defined as the following figure and shall be measured by switching the input signal for "black" and "white".

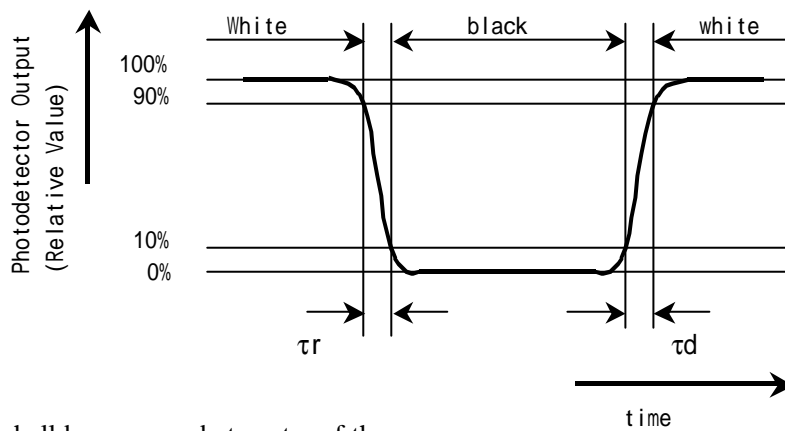

【Note4】 This shall be measured at center of the screen.

【Note5】 Definition of white uniformity:

White uniformity is defined as the following with five measurements

(A ~ E).

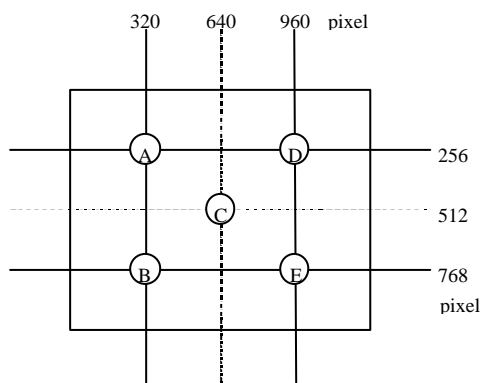

$$w = \frac{\text{Maximum Luminance of five points (brightness)}}{\text{Minimum Luminance of five points (brightness)}}$$

10. Handling Precautions

- a) Be sure to turn off the power supply when inserting or disconnecting the cable.
- b) Be sure to design the cabinet so that the module can be installed without any extra stress such as warp or twist.
- c) Since the front polarize is easily damaged, pay attention not to scratch it.
- d) Since long contact with water may cause discoloration or spots, wipe off water drop immediately.
- e) When the panel surface is soiled, wipe it with absorbent cotton or other soft cloth.
- f) Since the panel is made of glass, it may break or crack if dropped or bumped on hard surface. Handle with care.
- g) Since CMOS LSI is used in this module, take care of static electricity and take the human earth into consideration when handling.
- h) Make sure the four mounting holes of the module are grounded sufficiently. Take electro-magnetic interference (EMI) into consideration.
- i) The module has some printed circuit boards (PCBs) on the back side. Take care to keep them from any stress or pressure when handling or installing the module; otherwise some of electronic parts on the PCBs may be damaged.
- j) Observe all other precautionary requirements in handling components.
- k) When some pressure is added onto the module from rear side constantly, it causes display non-uniformity issue, functional defect, etc. So, please avoid such design.
- l) When giving a touch to the panel at power supply, it may cause some kinds of degradation. In that case, once turn off the power supply, and turn on after several seconds again, and that is disappear.
- m) When handling LCD modules and assembling them into cabinets, please be noted that long-term storage in the environment of oxidization or deoxidization gas and the use of such materials as reagent, solvent, adhesive, resin, etc. which generate these gasses, may cause corrosion and discoloration of the LCD modules.

11. Packing form

- a) Piling number of cartons : maximum 10 cartons
- b) Packing quantity in one carton : 2 module
- c) Carton size : 543mm(W) × 463mm(H) × 172(D)
- d) Total mass of one carton filled with full modules : 9.5 kg
- e) Packing form is shown in Fig.5

12 . Reliability test items

| No. | Test item | Conditions |
|-----|--|---|
| 1 | High temperature storage test | Ta=60 240h |
| 2 | Low temperature storage test | Ta=-25 240h |
| 3 | High temperature & high humidity operation test | Ta=40 ; 95%RH 240h (No condensation) |
| 4 | High temperature operation test | Ta=50 240h (The panel temp. must be less than 60) |
| 5 | Low temperature operation test | Ta=0 240H |
| 6 | Vibration test (non- operating) | Frequency : 10 ~ 57Hz/Vibration width (one side) : 0.075mm : 58 ~ 500Hz/Gravity : 9.8m/s ² Sweep time : 11minutes Test period : 3 hours (1 hour for each direction of X,Y,Z) |
| 7 | Shock test (non- operating) | Max. gravity : 490m/s ² Pulse width : 11ms, sine wave Direction : ± X, ± Y, ± Z, once for each direction. |

【Result Evaluation Criteria】

Under the display quality test conditions with normal operation state, these shall be no change which may affect practical display function.

13 . Others

1) Lot No. and indication Label:

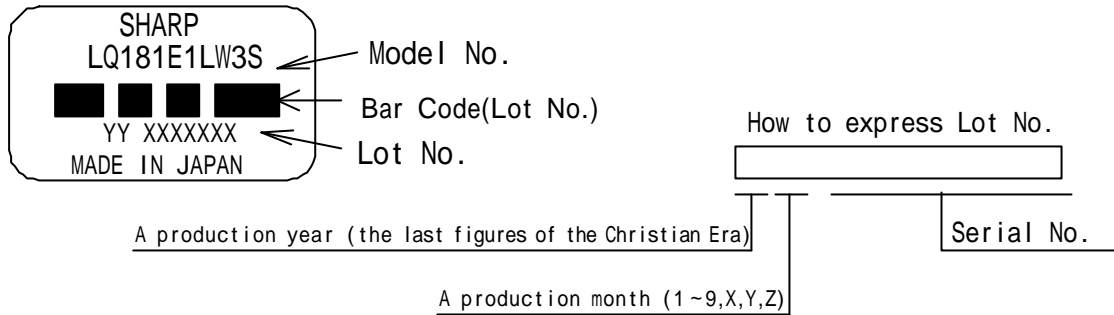

- 2) Adjusting volume have been set optimally before shipment, so do not change any adjusted value.
If adjusted value is changed, the specification may not be satisfied.
- 3) Disassembling the module can cause permanent damage and should be strictly avoided.
- 4) Please be careful since image retention may occur when a fixed pattern is displayed for a long time.
- 5) The chemical compound which causes the destruction of ozone layer is not being used.
- 6) Material information of LPG(Light Pipe Guide) are labeled on the back of the module.

MATERIAL INFORMATION
>PLASTIC LIGHT GUIDE:PMMA<

- 7) Cold cathode fluorescent lamp in LCD PANEL contains a small amount of mercury, Please follow local ordinances or regulations for disposal. (put on the back of the module. :Size: 63 × 14mm)

COLD CATHODE FLUORESCENT LAMP IN LCD PANEL
CONTAINS A SMALL AMOUNT OF MERCURY,PLEASE FOLLOW
LOCAL ORDINANCES OR REGULATION FOR DISPOSAL
当該液晶ディスプレイパネルは蛍光管が組み込まれていますので、地方自治体の条例、または、規則に従って廃棄ください。

- 8) When any question or issue occurs , it shall be solved by mutual discussion.

14. Carton storage condition

| | |
|-----------------------|--|
| Temperature | 0 to 40 |
| Humidity | 95%RH or less |
| Reference condition : | 20 to 35 , 85%RH or less (summer) : 5 to 15 , 85%RH or less (winter) • the total storage time (40 ,95%RH) : 240H or less |
| Sunlight | Be sure to shelter a product from the direct sunlight. |
| Atmosphere | Harmful gas, such as acid and alkali which bites electronic components and/or wires, must not be detected. |
| Notes | Be sure to put cartons on palette or base, don't put it on floor, and store them with removing from wall Please take care of ventilation in storehouse and around cartons, and control changing temperature is within limits of natural environment |
| Storage period | 1 year |

NOTES
 1) UNSPECIFIED TOLERANCE TO BE ± 0.5
 2) WARP AND FLATING FOR PCB AND CHASSIS ARE EXCLUDED FROM THICKNESS AND DIMENSIONS OF THE UNIT

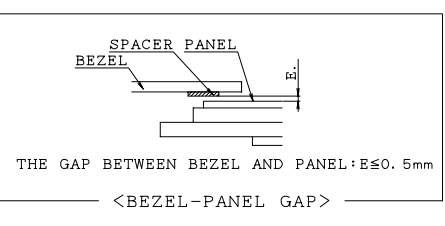
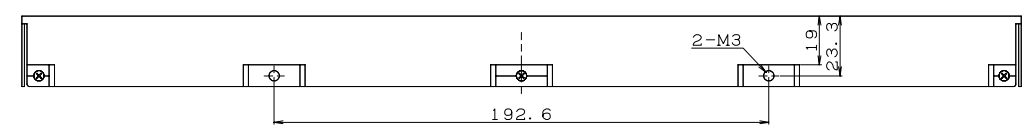
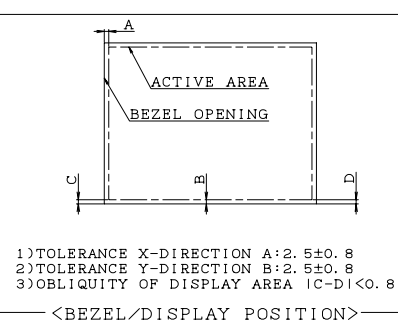
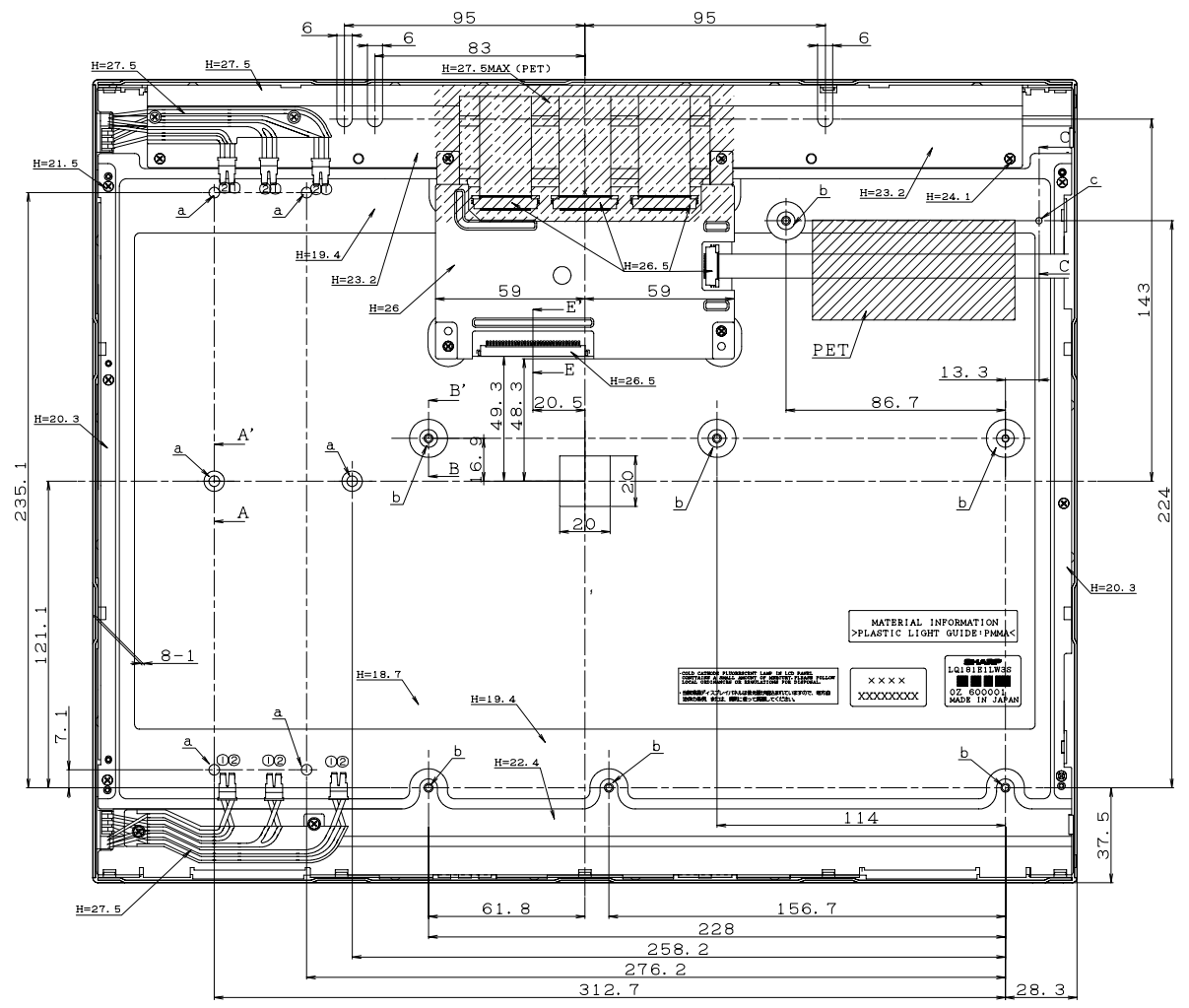
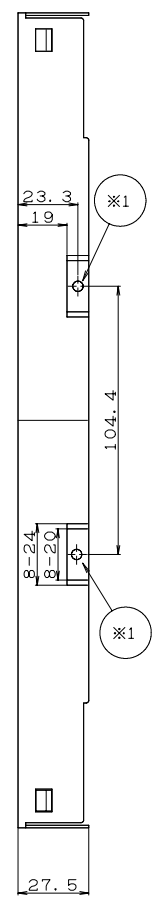
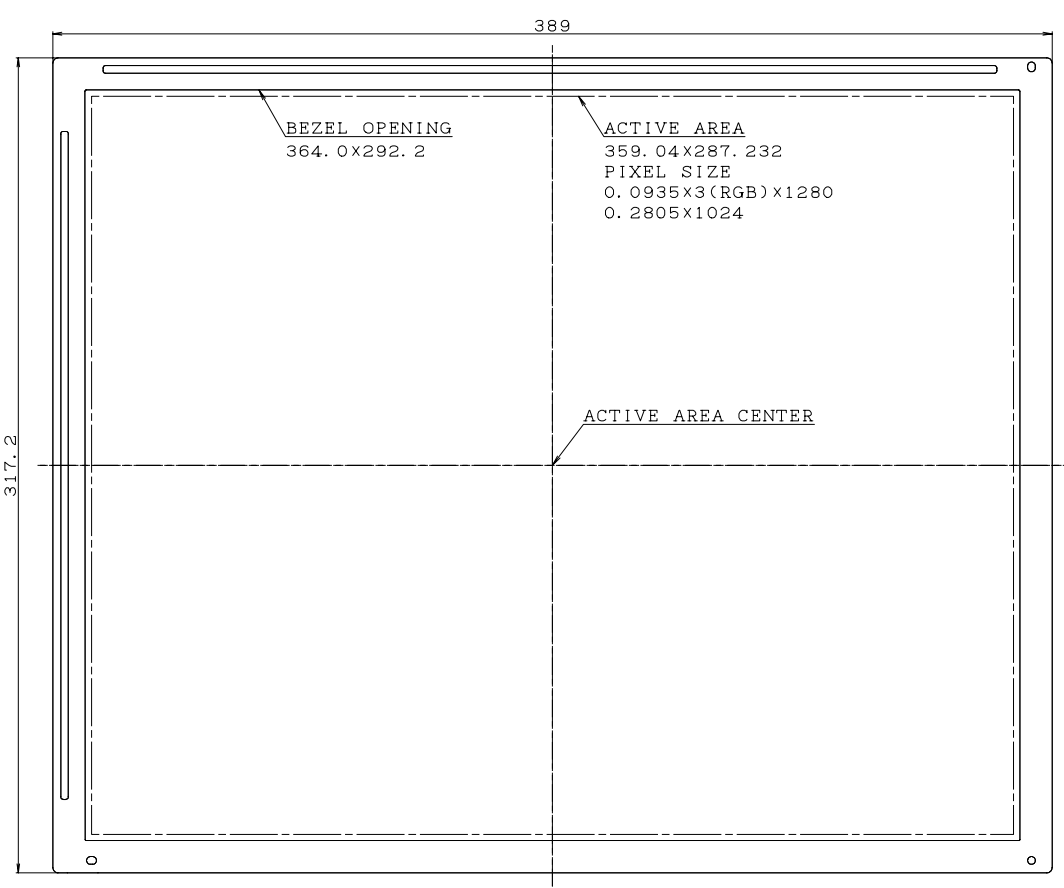
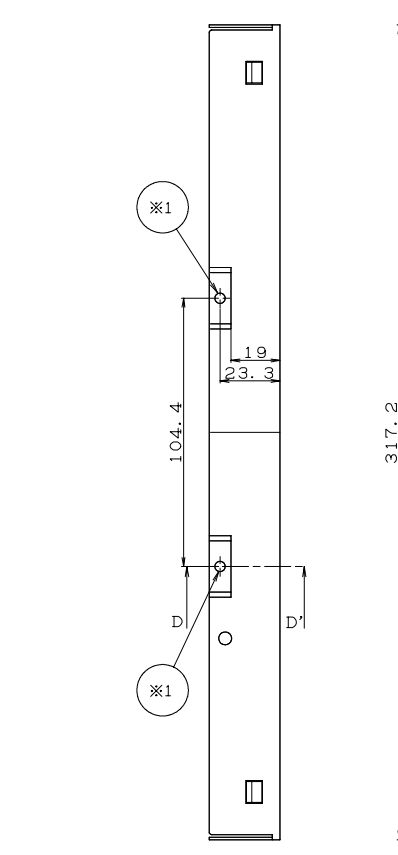
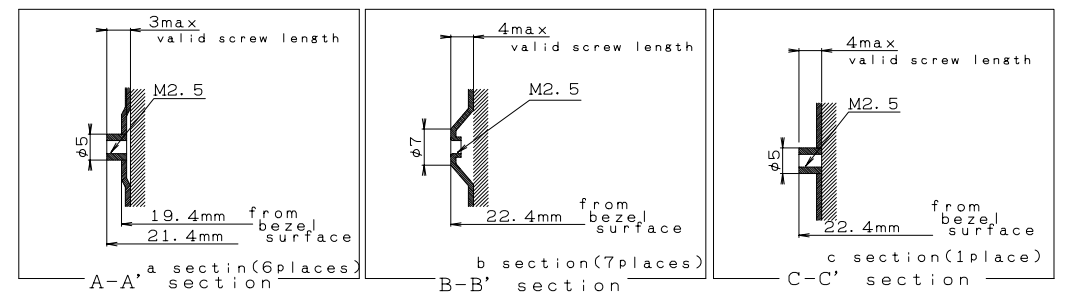
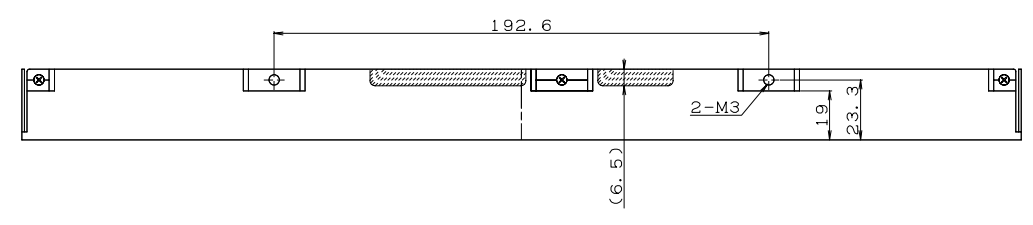
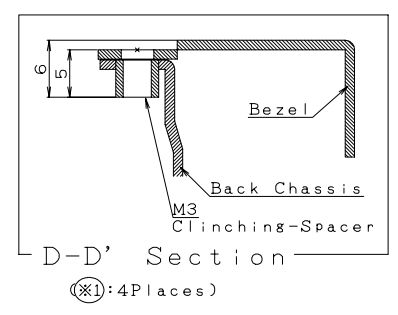

I/F CONNECTOR
 FI-SE30P-HF (JAE)
 CCFT CONNECTOR
 BHSR-02VS-1 (JST)
 1 High
 2 Gnd
 PIN LAYOUT

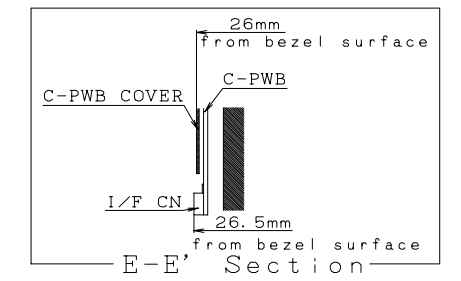
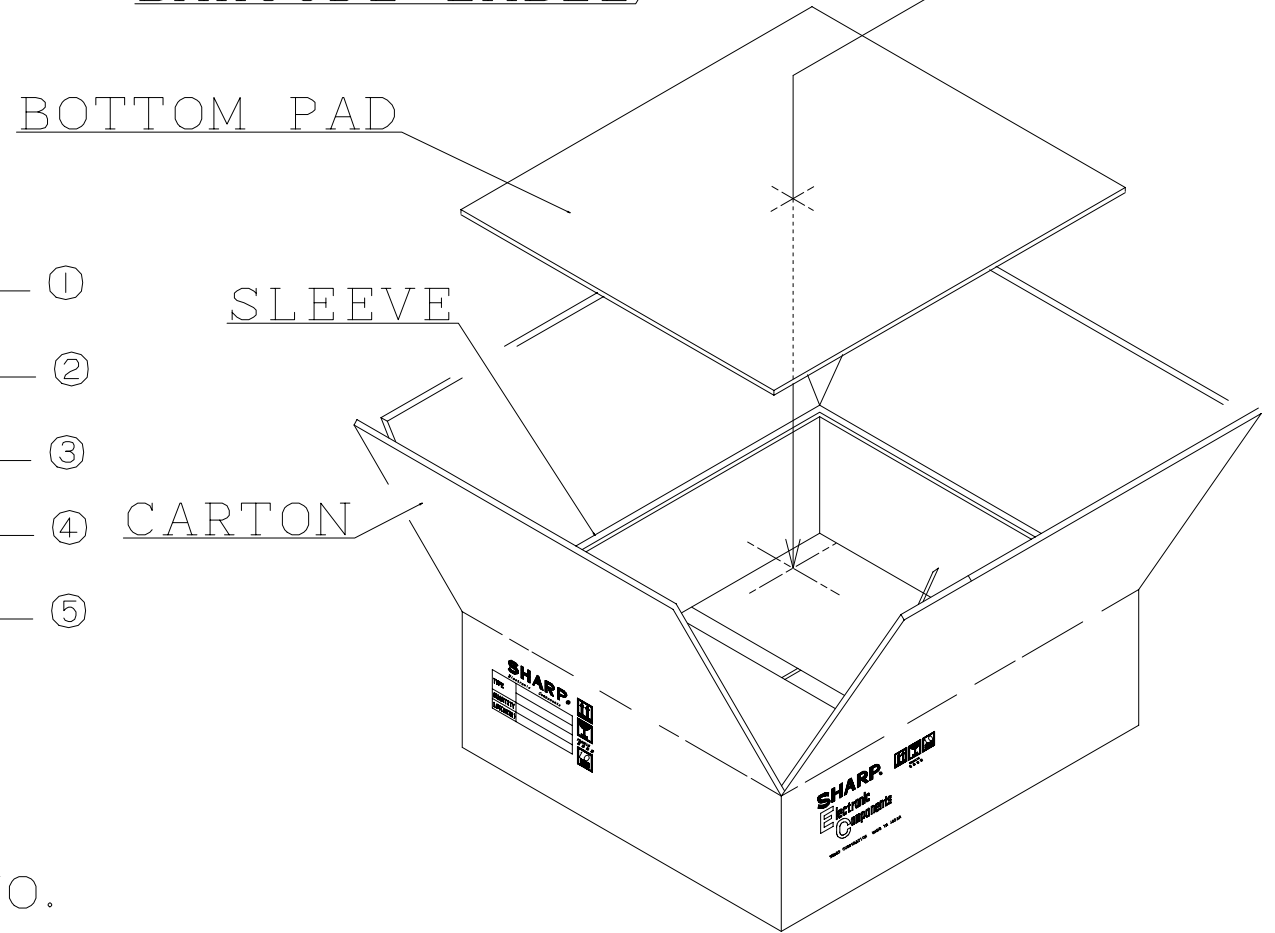
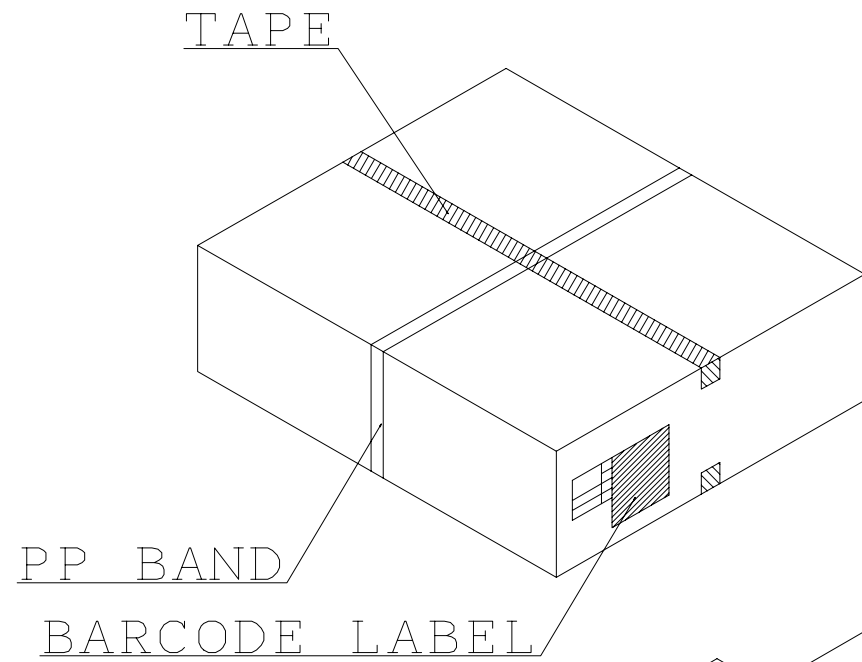

Fig 1. LQ181E1LW3S OUTLINE DIMENSIONS



BARCODE LABEL

| | |
|-------------------------|-----|
| 社内品番: (4S)LQ181E1LW3S | ← ① |
| LotNO. : (1T)2001.12.18 | ← ② |
| Quantity: (Q) 1 pcs | ← ③ |
| ユーザー品番 : | ← ④ |
| SHARP | ← ⑤ |

シャープ物用ラベルです。

- ①MODEL NO.
- ②LOT NO.
- ③QUANTITY
- ④USER MODEL NO.
- ⑤SHARP MODEL NO.

