



PREPARED BY : DATE	 LIQUID CRYSTAL DISPLAY GROUP SHARP CORPORATION SPECIFICATION	SPEC No. LD-22Z03D
APPROVED BY : DATE		FILE No. LD-22Z03D
		ISSUE : 16-Dec-11
		PAGE : 25pages
		APPLICABLE GROUP DISPLY DEVICE BUSINESS GROUP

REVISION : 12-Nov-12

DEVICE SPECIFICATION FOR
TFT-LCD Module
 MODEL No.
LQ190E1LW52

These parts have corresponded with the RoHS directive.

CUSTOMER'S APPROVAL
 BY _____

BY 
 J.Kawanishi
 GENERAL MANAGER
 ENGINEERING DEPARTMENT I
 DISPLY DEVICE DIVISION II
 DISPLY DEVICE BUSINESS GROUP
 SHARP CORPORATION

RECORDS OF REVISION

LQ190E1LW52

SPEC No.	DATE	REVI SED No	PAGE	SUMMARY	NOTE
LD-22Z03A	2011/12/16			-	
LD-22Z03B	2012/2/16	Δ1	P.15	Luminance of white(min) is changed. ILED=55mA: Min. 210cd/m2 ⇒240cd/m2 ILED=85mA: Min. 320cd/m2 ⇒360cd/m2	
			P.19	Add country of production to label	
LD-22Z03C	2012/5/10	Δ2	P.9	Error correction. V_{I1}/V_{I2} : "-0.3~Vcc+0.3V" ⇒ "-0.3~+3.6V"	
			P.9/18	The temperature range is changed. T_{STG} : -25~60°C ⇒ -25~65°C	
			P.12	Error correction. THd: "1280" ⇒ "640"	
			P.21	PET tape is added to "Fig.1 Outline dimension".	
			P.22	"Fig.3 Packing Form" is changed.	
LD-22Z03D	2012/11/12	Δ3	P.9/18	The operating temperature range is changed. T_{OPA} : 0~60°C ⇒ 0~65°C	

No.		page
1	Application	1
2	Overview	2
3	Mechanical Specifications	2
4	Input Terminals	3
5	Absolute Maximum Ratings	9
6	Electrical Characteristics	10
7	Timing characteristics of input signals	12
8	Input Signals, Basic Display Colors and Gray Scale of Each Color ..	13
9	Optical Characteristics	15
10	Handling Precautions	17
11	Packing form	18
12	Reliability test items	18
13	Others	19
14	Storage conditions	20
Fig.1	OUTLINE DIMENSIONS	21
Fig.3	PACKING FORM	22

1. Application

This specification applies to the color TFT-LCD module LQ190E1LW52.

This specification is the proprietary product of SHARP CORPORATION (SHARP) and include materials protected under copyright of SHARP. Do not reproduce or cause any third party to reproduce them in any form or by any means, electronic or mechanical, for any purpose, in whole or in part, without the express written permission of SHARP.

The device listed in this specification was designed and manufactured for use in general electronic equipment.

In case of using the device for applications such as control and safety equipment for transportation (controls of aircraft, trains, automobiles, etc.), rescue and security equipment and various safety related equipment which require higher reliability and safety, take into consideration that appropriate measures such as fail-safe functions and redundant system design should be taken.

Do not use the device for equipment that requires an extreme level of reliability, such as aerospace applications, telecommunication equipment (trunk lines), nuclear power control equipment and medical or other equipment for life support.

SHARP assumes no responsibility for any damage resulting from the use of the device which does not comply with the instructions and the precautions specified in this specification .

Contact and consult with a SHARP sales representative for any questions about this device.

2. Overview

This module is a color active matrix LCD module incorporating amorphous silicon TFT (Thin Film Transistor). It is composed of a color TFT-LCD panel, driver ICs, control circuit, power supply circuit and a White-LED Backlight unit. Graphics and texts can be displayed on a 1280 × RGB × 1024dots panel with about 16 million colors by using LVDS (Low Voltage Differential Signaling) and supplying +5.0V DC supply voltages for TFT-LCD panel driving and supply voltage for backlight.

It is a wide viewing-angle-module.

LED-Backlight driver is not built in this module.

3. Mechanical technical literatures

Parameter	technical literatures	Unit
Display size	48(19inch) Diagonal	cm
Active area	376.32(H) × 301.056(V)	mm
Pixel format	1280(H) × 1024(V) (1pixel=R+G+B dot)	pixel
Aspect ratio	5:4	
Pixel pitch	0.294(H) × 0.294(V)	mm
Pixel configuration	R,G,B vertical stripe	
Display mode	Normally black	
Unit outline dimensions 【*1】	404.2(W) × 330.0(H) × 15.0(D)	mm
Mass	1850 (Max.)	g
Surface treatment (Haze value)	Anti-glare and hard-coating 2H(40%)	

【*1】 Excluding the protrusion of the connector cover from thickness.

Outline dimensions are shown in Fig.1.

4. Input Terminals

4-1. TFT-LCD panel driving

CN1 (Interface signals and +5V power supply)

Using connectors: FI-X30SSL-HF (Japan Aviation Electronics Industry, Limited)

Corresponding connectors: FI-X30M (FPC type) (Japan Aviation Electronics Industry, Limited)

: FI-X30H (Wire type), FI-X30HL (Wire type with lock)

: FI-X30C (Coaxial cable type), FI-X30G2L (Coaxial cable type with lock)

Using LVDS receiver: Building into control IC (THC63LVDF84B (Thine electronics) or Compatible product)

Corresponding LVDS transmitter: THC63LVDM83D (Thine electronics) or Compatible product

CN1

Pin	Symbol	Function	Remark
1	RxO0-	Receiver signal of LVDS (O0-)	LVDS
2	RxO0+	Receiver signal of LVDS (O0+)	LVDS
3	RxO1-	Receiver signal of LVDS (O1-)	LVDS
4	RxO1+	Receiver signal of LVDS (O1+)	LVDS
5	RxO2-	Receiver signal of LVDS (O2-)	LVDS
6	RxO2+	Receiver signal of LVDS (O2+)	LVDS
7	GND	GND	
8	RxOC-	Receiver signal of LVDS (OC-)	LVDS
9	RxOC+	Receiver signal of LVDS (OC+)	LVDS
10	RxO3-	Receiver signal of LVDS (O3-)	LVDS
11	RxO3+	Receiver signal of LVDS (O3+)	LVDS
12	RxE0-	Receiver signal of LVDS (E0-)	LVDS
13	RxE0+	Receiver signal of LVDS (E0+)	LVDS
14	GND	GND	
15	RxE1-	Receiver signal of LVDS (E1-)	LVDS
16	RxE1+	Receiver signal of LVDS (E1+)	LVDS
17	GND	GND	
18	RxE2-	Receiver signal of LVDS (E2-)	LVDS
19	RxE2+	Receiver signal of LVDS (E2+)	LVDS
20	RxEC-	Receiver signal of LVDS (EC-)	LVDS
21	RxEC+	Receiver signal of LVDS (EC+)	LVDS
22	RxE3-	Receiver signal of LVDS (E3-)	LVDS
23	RxE3+	Receiver signal of LVDS (E3+)	LVDS
24	GND	GND	
25	SELLVDS	Selection of LVDS mapping	【*1】
26	N.C.		
27	N.C.		
28	VCC	+5V power supply	
29	VCC	+5V power supply	
30	VCC	+5V power supply	

【*1】 SELLVDS is shown in 4-2.

4-2. Data Mapping

1) 8 bit input

pin assignment with SELLVDS pin (THC63LVDM83D (Thine electronics) or Compatible product)

Transmitter		25Pin SELLVDS	
Pin No	Data	= H(3.3V)	= L(GND) or Open
51	TA0	R0 (LSB)	R2
52	TA1	R1	R3
54	TA2	R2	R4
55	TA3	R3	R5
56	TA4	R4	R6
3	TA5	R5	R7 (MSB)
4	TA6	G0 (LSB)	G2
6	TB0	G1	G3
7	TB1	G2	G4
11	TB2	G3	G5
12	TB3	G4	G6
14	TB4	G5	G7 (MSB)
15	TB5	B0 (LSB)	B2
19	TB6	B1	B3
20	TC0	B2	B4
22	TC1	B3	B5
23	TC2	B4	B6
24	TC3	B5	B7 (MSB)
27	TC4	(NA)	(NA)
28	TC5	(NA)	(NA)
30	TC6	DE	DE
50	TD0	R6	R0 (LSB)
2	TD1	R7 (MSB)	R1
8	TD2	G6	G0 (LSB)
10	TD3	G7 (MSB)	G1
16	TD4	B6	B0 (LSB)
18	TD5	B7 (MSB)	B1
25	TD6	(NA)	(NA)

< SELLVDS = H(3.3V) >

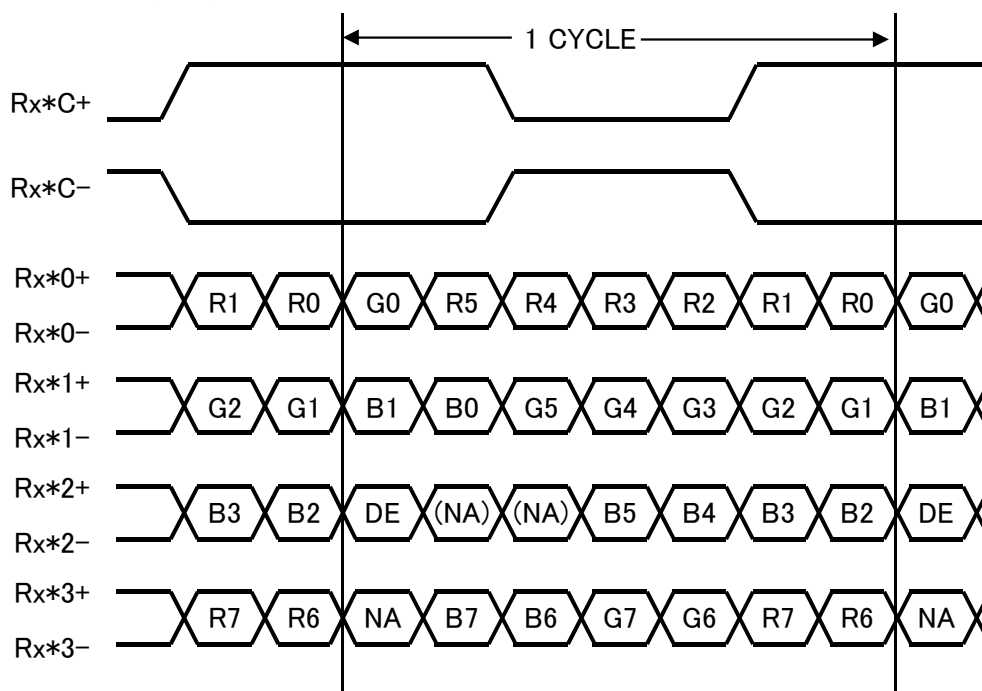

< SELLVDS = L(GND) or Open >

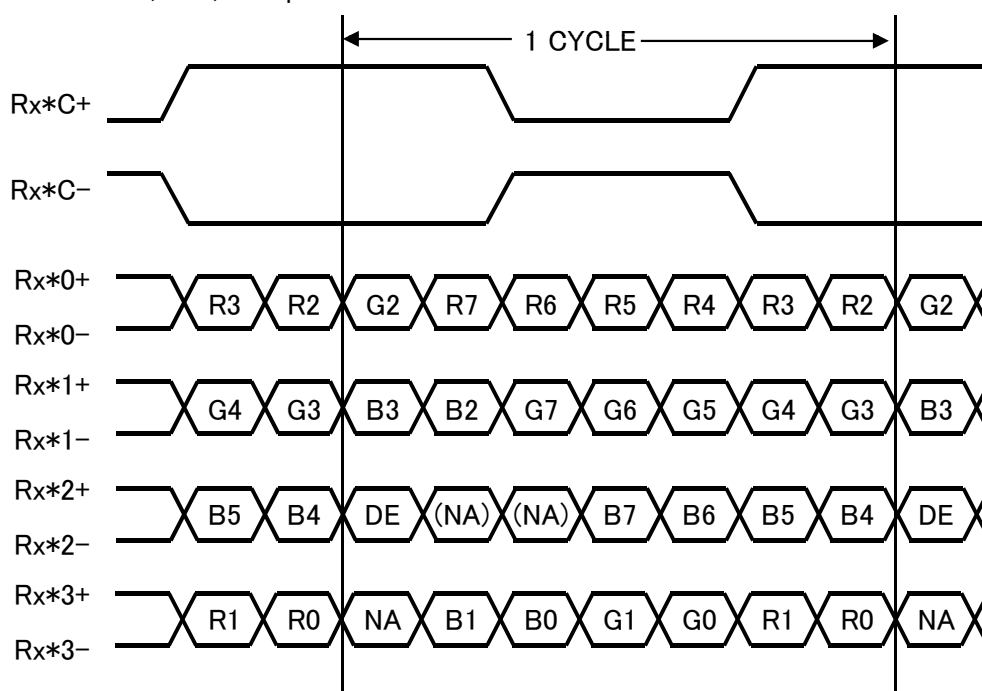

*: O or E

DE: DATA ENABLE

NA: Non Available

1) 6bit input

pin assignment with SELLVDS (THC63LVDM83D(Thine electronics) or Compatible product)

Transmitter		25Pin SELLVDS	
Pin No	Data	= H(3.3V)	= L(GND) or Open
51	TA0	-	R0 (LSB)
52	TA1	-	R1
54	TA2	-	R2
55	TA3	-	R3
56	TA4	-	R4
3	TA5	-	R5 (MSB)
4	TA6	-	G0 (LSB)
6	TB0	-	G1
7	TB1	-	G2
11	TB2	-	G3
12	TB3	-	G4
14	TB4	-	G5 (MSB)
15	TB5	-	B0 (LSB)
19	TB6	-	B1
20	TC0	-	B2
22	TC1	-	B3
23	TC2	-	B4
24	TC3	-	B5 (MSB)
27	TC4	-	(NA)
28	TC5	-	(NA)
30	TC6	-	DE
50	TD0	-	GND
2	TD1	-	GND
8	TD2	-	GND
10	TD3	-	GND
16	TD4	-	GND
18	TD5	-	GND
25	TD6	-	(NA)

< SELLVDS = L(GND) or Open >

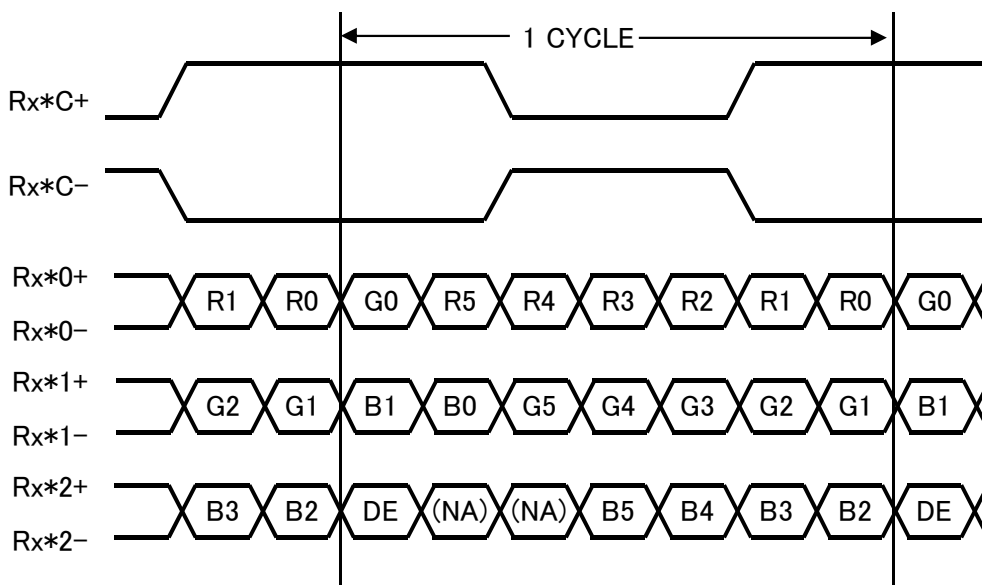

*: O or E

DE: DATA ENABLE

NA: Non Available

Recommended input (at 6bit)

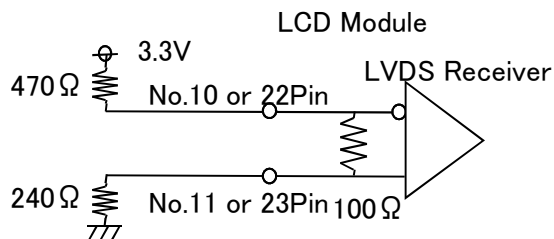
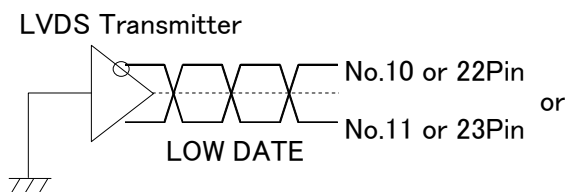

4-3. LED backlight

LED backlight connector

CN2,3 Used connector : 5015680607 (MOLEX)
 Corresponding connector : 5013300600 (MOLEX)

Connector No.	Pin No.	symbol	function
CN2,3	1	VLED	LED power supply
	2	ILED1	LED current sense for string 1
	3	ILED2	LED current sense for string 2
	4	ILED3	LED current sense for string 3
	5	ILED4	LED current sense for string 4
	6	ILED5	LED current sense for string 5

4-4. Interface block diagram

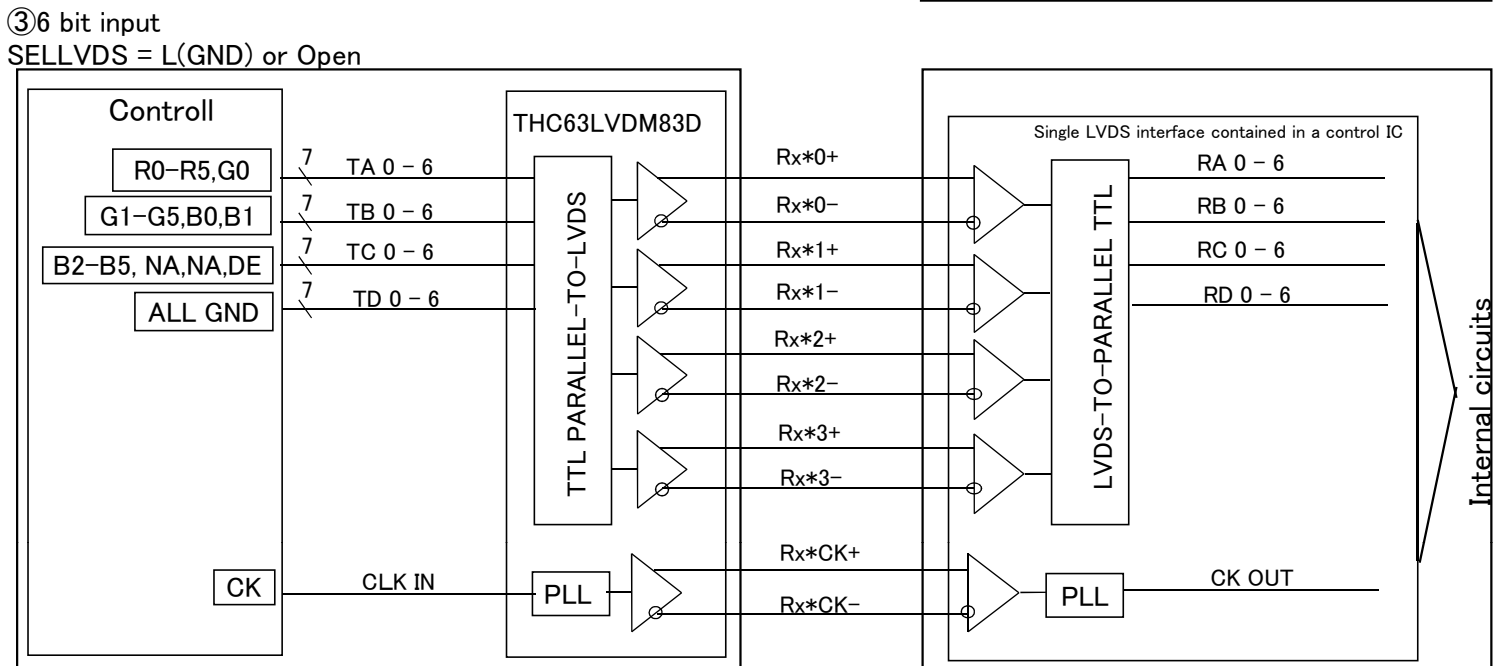
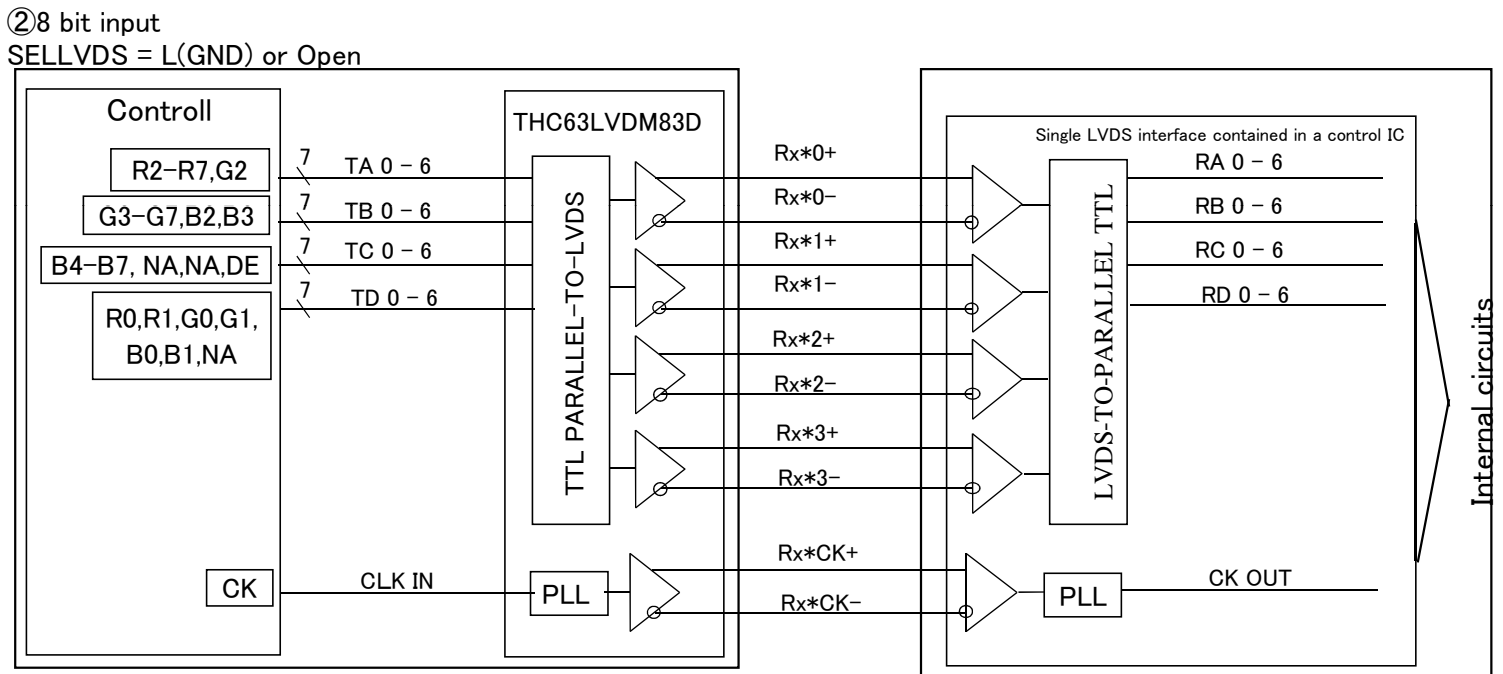
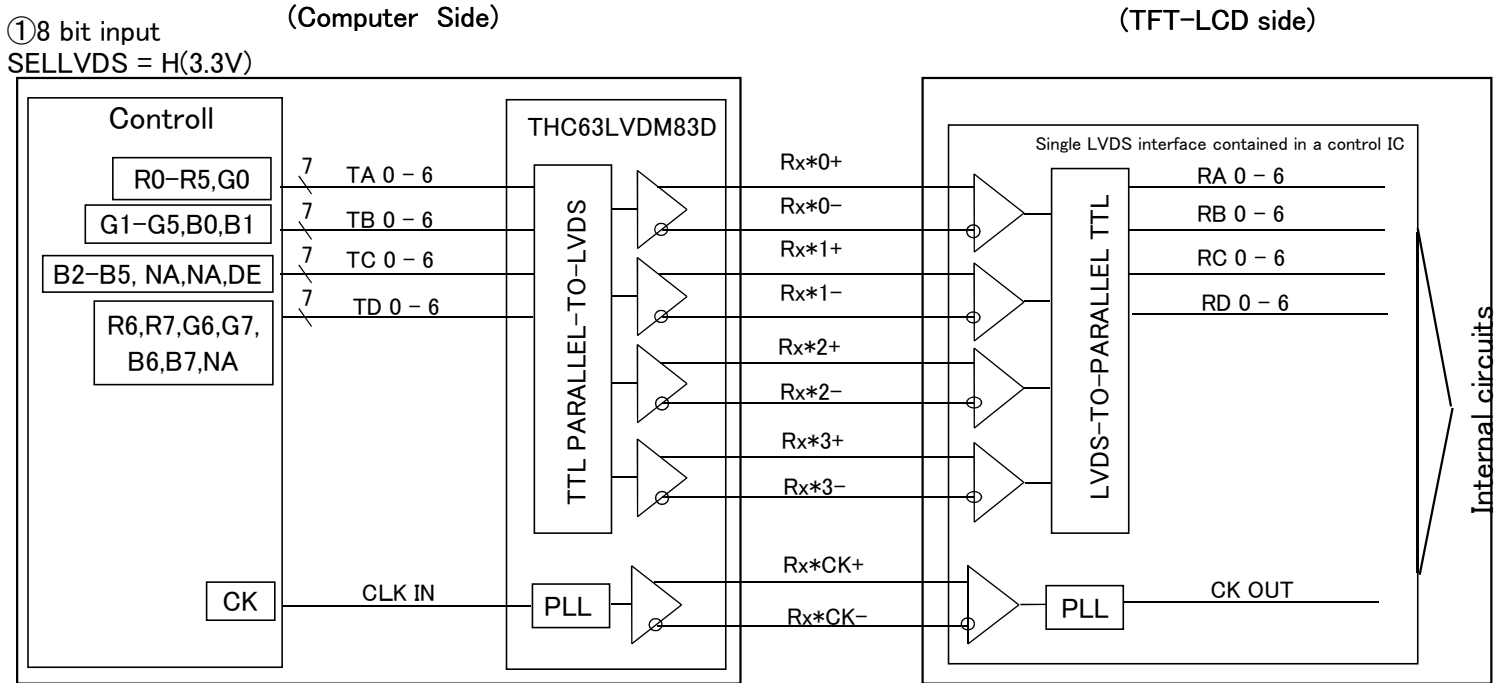

5. Absolute Maximum Ratings

Parameter	Symbol	Condition	Pin	Ratings	Unit	Remark
Supply voltage	V _{CC}	T _a =25°C	VCC	-0.3 ~ +6.0	V	【*1,2】
Input voltage	V _{I1}	T _a =25°C	Rx*i -/+ Rx*CK -/+	-0.3 ~ +3.6	V	i=0,1,2,3 Δ2
	V _{I2}	T _a =25°C	SELLVDS	-0.3 ~ +3.6	V	Δ2
LED current	I _{LED}	T _a =25°C	I _{LED}	0~100	mA	for 1ch
Storage temperature	T _{STG}	—	—	-25 ~ +65	°C	【*1】 Δ2
Operating temperature	T _{OPA}	—	—	0 ~ +65	°C	【*1,3,4】 Δ3

【*1】 Humidity: 95%RH Max.(T_a ≤ 40°C) Note static electricity.

Maximum wet-bulb temperature at 39°C or less. (T_a > 40°C) No condensation.

【*2】 The V_{CC} power supply capacity must use the one of 3A or more.

【*3】 There is a possibility of causing deterioration in the irregularity and others of the screen and the display fineness when using it around 65°C.

【*4】 In the operating temperature item, the low temperature side is the ambient temperature regulations.

The high temperature side is the panel surface temperature regulations.

6. Electrical Characteristics

6-1. TFT-LCD panel driving

 $T_a = +25^\circ\text{C}$

Parameter	Symbol	Condition	Min.	Typ.	Max.	Unit	Remark
Supply voltage	V_{CC}		4.75	5.0	5.25	V	【*1】
Current dissipation	I_{CC}	$V_{CC}=5V$	—	750	1400	mA	【*2】
Input voltage width for LVDS receiver	V_L		0	—	2.4	V	
Permissible input ripple voltage	V_{RP}		—	—	200	mV _{P-P}	$V_{CC} = 5V$
Differential input Threshold voltage	High	V_{TH}	—	—	$V_{CM} + 100$	mV	$V_{CM} = +1.2V$ 【*3】
	Low	V_{TL}	$V_{CM} - 100$	—	—	mV	
Input voltage		V_{IH}	2.2	—	3.3	V	【*4】
		V_{IL}	0.0	—	0.8	V	
Input reak current		I_{OH}	—	—	400	μA	$V_{I2} = +5V$ 【*4】
		I_{OL}	-10	—	+10	μA	$V_{I2} = 0V$ 【*4】
Terminal resistor	R_T		—	100	—	Ω	Differential input

【*1】 On-off conditions for supply voltage

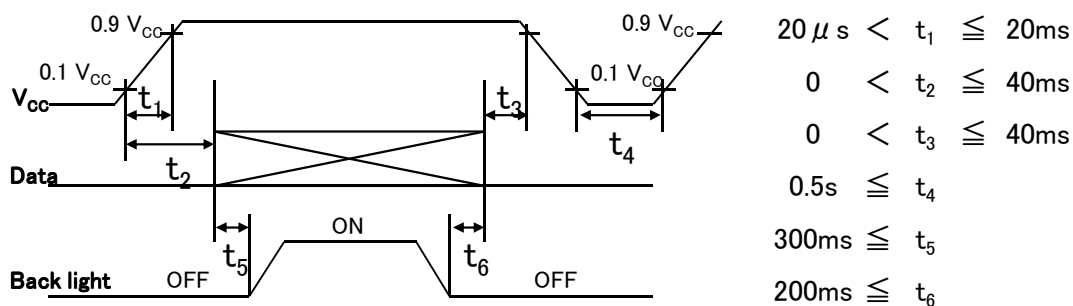

V_{CC} -dip conditions

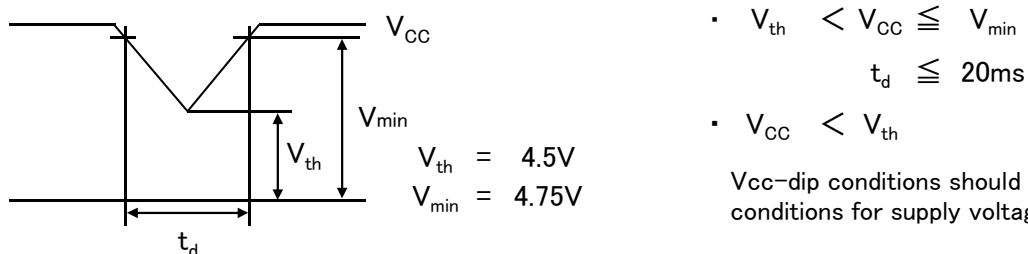

V_{CC} -dip conditions should also follow the On-off conditions for supply voltage

- Hsync/Vsync need not be input so that this model may drive only by the ENAB signal.
- The relation between the data input and the backlight lighting will recommend the above-mentioned input sequence. When the backlight is turned on before the panel operates, there is a possibility of abnormally displaying. The liquid crystal module is not damaged.

【*2】 Current dissipation

Typical current situation : 253-gray-bar pattern
 ($V_{CC}=+5V$, $f_{ck} = 54MHz$, $T_a=25^\circ C$)

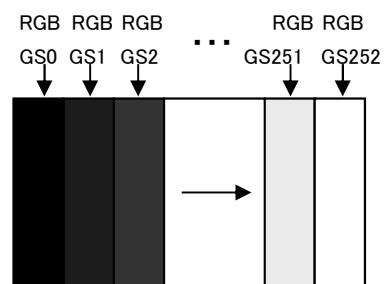

【*3】 V_{CM} : LVDS common mode voltage

【*4】 SELLVDS

6-2. LED backlight

Ta=+25°C

Parameter	Symbol	Min.	Typ.	Max.	Unit	Remark
Supply voltage	V _{LED}	–	21.0	23.8	V	【*1】
Current dissipation	I _{LED}	–	55	90	mA	【*2】
		–	85	90	mA	【*3】
Number of LED channels		–	10			【*4】
Power Consumption	P _{LED}	–	11.6	–	W	【*1,2,5】
		–	17.9	21.5	W	【*1,3,5】
Life time	L	–	(50,000) (Module)	–	h	【Reference】 【*1,2,6】
			(30,000) (Module)	–	h	【Reference】 【*1,3,7】

【*1】 There are two Light Bars, and the specified current is input LED chip 100% duty current.

【*2】 The LED current for each string for the luminance of module 300cd/m².

【*3】 The LED current for each string for the luminance of module 450cd/m².

【*4】 This module use two LED bar. Each LED bar consist of 5ch.

【*5】 $P_{LED} = I_{LED} \times V_{LED} \times 10ch$.

【*6】 The life time is determined as the time at which luminance of the LED becomes 50% of the initial brightness or not normal lighting at I_{LED} =55 mA on condition of continuous operating at 25°C.

【*7】 The life time is determined as the time at which luminance of the LED becomes 50% of the initial brightness or not normal lighting at I_{LED} =85 mA on condition of continuous operating at 25°C.

【Note】 Please do not connect the channel of the LED in parallel.

The overcurrent flows to one channel where VL is low when VL of each channel is different, and the LED longevity might shorten.

Please drive the LED of each channel at a constant current.

Please design to connect the current limitation resistance without fail in the circuit, and to drive in ratings.

Please design so that the excess voltage (overcurrent) should not hang momentarily when the circuit is turned on, and turned off.

Please design so that the average current value may become it in ratings when it is used by the pulse drive.

In case of using pulse drive for backlight driving, please keep frequency enough high in order to avoid the flicker or the deterioration of display quality.

Please design so that the backward voltage should not hang when LED is turned off.

Please build the protection circuit into the system to not generate the overcurrent and overvoltage in abnormal circumstances.

7. Timing characteristics of input signals

7-1. Timing characteristics

Parameter	Symbol	Min.	Typ.	Max.	Unit	Remark	
Clock	Frequency	1/Tc	40	54	70	MHz	
ENAB	Horizontal period	TH	670	844	929	clock	
			12.3	15.6	-	μ s	
	Horizontal period (High)	THd	640	640	640	clock	$\Delta 2$
	Vertical Frequency	TV	1031	1066	2043	line	【*1】
			13.1	16.7	-	ms	
Vertical period (High)	TVd	1024	1024	1024	line		

【*1】 In case of using the long vertical period, the deterioration of display quality, flicker etc. may occur.

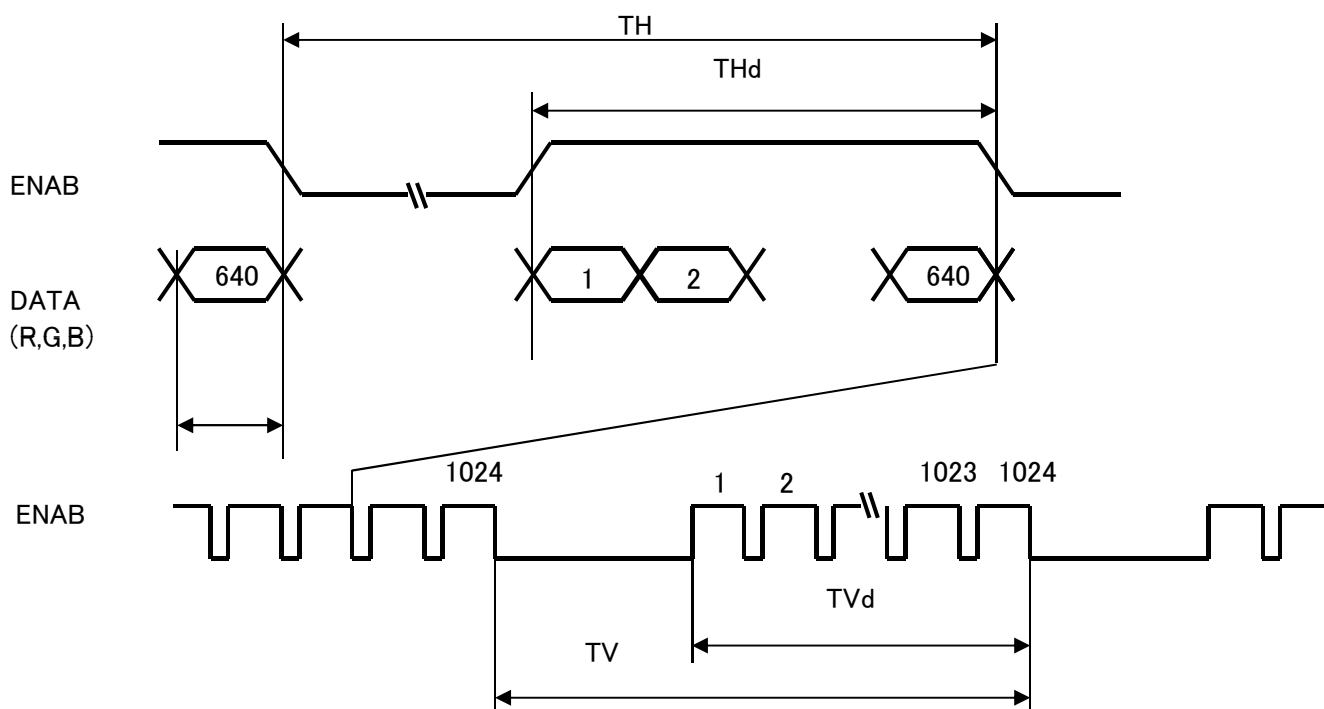

7-2. Input Data Signals and Display Position on the screen

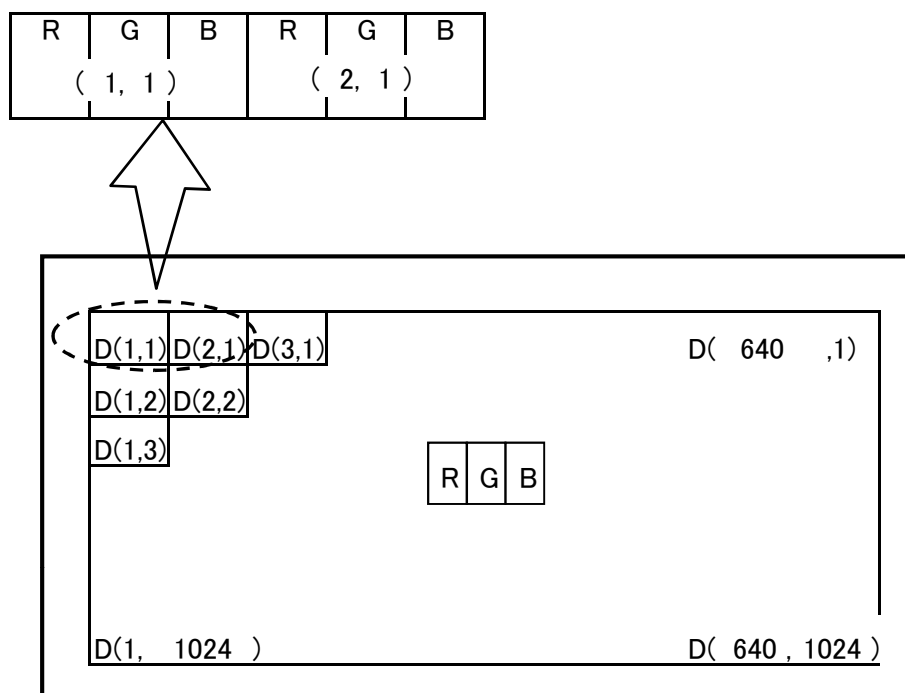

8. Input Signals, Basic Display Colors and Gray Scale of Each Color

8-1. 8 bit input

Colors & Gray scale	Data signal																								
	Gray Scale	R0	R1	R2	R3	R4	R5	R6	R7	G0	G1	G2	G3	G4	G5	G6	G7	B0	B1	B2	B3	B4	B5	B6	B7
Basic Color	Black	—	0	0	0	0	0	0	0	0	0	0	0	0	0	0	0	0	0	0	0	0	0	0	0
	Blue	—	0	0	0	0	0	0	0	0	0	0	0	0	0	0	0	0	X	X	1	1	1	1	1
	Green	—	0	0	0	0	0	0	0	0	X	X	1	1	1	1	1	1	0	0	0	0	0	0	0
	Cyan	—	0	0	0	0	0	0	0	0	X	X	1	1	1	1	1	1	X	X	1	1	1	1	1
	Red	—	X	X	1	1	1	1	1	1	0	0	0	0	0	0	0	0	0	0	0	0	0	0	0
	Magenta	—	X	X	1	1	1	1	1	1	0	0	0	0	0	0	0	0	X	X	1	1	1	1	1
	Yellow	—	X	X	1	1	1	1	1	1	X	X	1	1	1	1	1	1	0	0	0	0	0	0	0
	White	—	X	X	1	1	1	1	1	1	X	X	1	1	1	1	1	1	X	X	1	1	1	1	1
Gray Scale of Red	Black	GS0	0	0	0	0	0	0	0	0	0	0	0	0	0	0	0	0	0	0	0	0	0	0	
	↑	GS1	1	0	0	0	0	0	0	0	0	0	0	0	0	0	0	0	0	0	0	0	0	0	
	Darker	GS2	0	1	0	0	0	0	0	0	0	0	0	0	0	0	0	0	0	0	0	0	0	0	
	↑	↑	↑							↑							↑								
	↓	↓	↓							↓							↓								
	Brighter	GS250	0	1	0	1	1	1	1	1	0	0	0	0	0	0	0	0	0	0	0	0	0	0	0
	↓	GS251	1	1	0	1	1	1	1	1	0	0	0	0	0	0	0	0	0	0	0	0	0	0	0
Red	GS252	X	X	1	1	1	1	1	1	0	0	0	0	0	0	0	0	0	0	0	0	0	0	0	
Gray Scale of Green	Black	GS0	0	0	0	0	0	0	0	0	0	0	0	0	0	0	0	0	0	0	0	0	0	0	
	↑	GS1	0	0	0	0	0	0	0	0	1	0	0	0	0	0	0	0	0	0	0	0	0	0	
	Darker	GS2	0	0	0	0	0	0	0	0	0	1	0	0	0	0	0	0	0	0	0	0	0	0	
	↑	↑	↑							↑							↑								
	↓	↓	↓							↓							↓								
	Brighter	GS250	0	0	0	0	0	0	0	0	0	1	0	1	1	1	1	1	0	0	0	0	0	0	0
	↓	GS251	0	0	0	0	0	0	0	0	1	1	0	1	1	1	1	1	0	0	0	0	0	0	0
Green	GS252	0	0	0	0	0	0	0	0	X	X	1	1	1	1	1	1	0	0	0	0	0	0	0	
Gray Scale of Blue	Black	GS0	0	0	0	0	0	0	0	0	0	0	0	0	0	0	0	0	0	0	0	0	0	0	
	↑	GS1	0	0	0	0	0	0	0	0	0	0	0	0	0	0	0	0	1	0	0	0	0	0	
	Darker	GS2	0	0	0	0	0	0	0	0	0	0	0	0	0	0	0	0	0	1	0	0	0	0	
	↑	↑	↑							↑							↑								
	↓	↓	↓							↓							↓								
	Brighter	GS250	0	0	0	0	0	0	0	0	0	0	0	0	0	0	0	0	0	1	0	1	1	1	1
	↓	GS251	0	0	0	0	0	0	0	0	0	0	0	0	0	0	0	0	1	1	0	1	1	1	1
Blue	GS252	0	0	0	0	0	0	0	0	0	0	0	0	0	0	0	0	X	X	1	1	1	1	1	

0 :Low level voltage 1 :High level voltage X :Don't care

Each basic color can be displayed in 253 gray scales from 8 bit data signals. According to the combination of, total 24 bit data signals, the 16-million-color display can be achieved on the screen.

8-2. 6 bit input

	Colors & Gray scale	Data signal																		
		GrayScale	R0	R1	R2	R3	R4	R5	G0	G1	G2	G3	G4	G5	B0	B1	B2	B3	B4	B5
Basic Color	Black	—	0	0	0	0	0	0	0	0	0	0	0	0	0	0	0	0	0	0
	Blue	—	0	0	0	0	0	0	0	0	0	0	0	0	1	1	1	1	1	1
	Green	—	0	0	0	0	0	0	1	1	1	1	1	1	0	0	0	0	0	0
	Cyan	—	0	0	0	0	0	0	1	1	1	1	1	1	1	1	1	1	1	1
	Red	—	1	1	1	1	1	1	0	0	0	0	0	0	0	0	0	0	0	0
	Magenta	—	1	1	1	1	1	1	0	0	0	0	0	0	1	1	1	1	1	1
	Yellow	—	1	1	1	1	1	1	1	1	1	1	1	1	0	0	0	0	0	0
	White	—	1	1	1	1	1	1	1	1	1	1	1	1	1	1	1	1	1	1
Gray Scale of Red	Black	GS0	0	0	0	0	0	0	0	0	0	0	0	0	0	0	0	0	0	0
	↑	GS1	1	0	0	0	0	0	0	0	0	0	0	0	0	0	0	0	0	0
	Darker	GS2	0	1	0	0	0	0	0	0	0	0	0	0	0	0	0	0	0	0
	↑	↓	↓					↓					↓							
	↓	↓	↓					↓					↓							
	Brighter	GS61	1	0	1	1	1	1	0	0	0	0	0	0	0	0	0	0	0	0
	↓	GS62	0	1	1	1	1	1	0	0	0	0	0	0	0	0	0	0	0	0
Red	GS63	1	1	1	1	1	1	0	0	0	0	0	0	0	0	0	0	0	0	
Gray Scale of Green	Black	GS0	0	0	0	0	0	0	0	0	0	0	0	0	0	0	0	0	0	0
	↑	GS1	0	0	0	0	0	0	1	0	0	0	0	0	0	0	0	0	0	0
	Darker	GS2	0	0	0	0	0	0	0	1	0	0	0	0	0	0	0	0	0	0
	↑	↓	↓					↓					↓							
	↓	↓	↓					↓					↓							
	Brighter	GS61	0	0	0	0	0	0	1	0	1	1	1	1	0	0	0	0	0	0
	↓	GS62	0	0	0	0	0	0	0	1	1	1	1	1	0	0	0	0	0	0
Green	GS63	0	0	0	0	0	0	1	1	1	1	1	1	0	0	0	0	0	0	
Gray Scale of Blue	Black	GS0	0	0	0	0	0	0	0	0	0	0	0	0	0	0	0	0	0	0
	↑	GS1	0	0	0	0	0	0	0	0	0	0	0	0	1	0	0	0	0	0
	Darker	GS2	0	0	0	0	0	0	0	0	0	0	0	0	0	1	0	0	0	0
	↑	↓	↓					↓					↓							
	↓	↓	↓					↓					↓							
	Brighter	GS61	0	0	0	0	0	0	0	0	0	0	0	0	1	0	1	1	1	1
	↓	GS62	0	0	0	0	0	0	0	0	0	0	0	0	0	1	1	1	1	1
Blue	GS63	0	0	0	0	0	0	0	0	0	0	0	0	1	1	1	1	1	1	

Each basic color can be displayed in 64 gray scales from 6 bit data signals. According to the combination of total 18 bit data signals, the 262,144-color display can be achieved on the screen.

9. Optical Characteristics

$T_a=+25^{\circ}\text{C}$, $V_{cc}=+5\text{V}$

Parameter		Symbol	Condition	Min.	Typ.	Max.	Unit	Remark
Viewing angle range	Horizontal	θ_{21}, θ_{22}	CR>10	85	-	-	Deg.	【*1,2,4】
	Vertical	θ_{11}		85	-	-	Deg.	
		θ_{12}		-	80	-	Deg.	
Contrast ratio		CR	optimized angle	400	1000	-		【*2,4】
Response Time	White Black	$\tau_r + \tau_d$	$\theta = 0^{\circ}$	-	12	-	ms	【*3,4】
Chromaticity of White	Wx			0.250	0.300	0.350		【*4】
	Wy			0.270	0.320	0.370		
Chromaticity of Red	Rx			-	0.640	-		
	Ry			-	0.345	-		
Chromaticity of Green	Gx			-	0.315	-		
	Gy			-	0.630	-		
Chromaticity of Blue	Bx			-	0.150	-		
	By			-	0.080	-		
Luminance of white	Y_{L1}			240	300	-	cd/m ²	
			360	450	-	cd/m ²	$I_{LED}=85\text{mA}$ 【*4】 $\Delta 1$	
White Uniformity				-	-	1.43		【*5】

※The measurement shall be executed 30 minutes after lighting at rating.

The optical characteristics shall be measured in a dark room or equivalent state with the method shown in Fig.2 below.

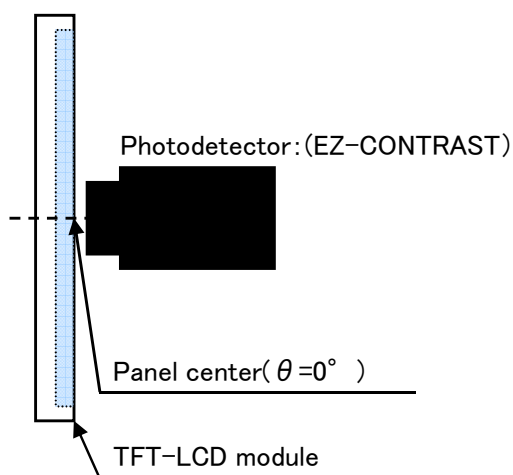

fig.2-1 Measuring method of Viewing angle range.

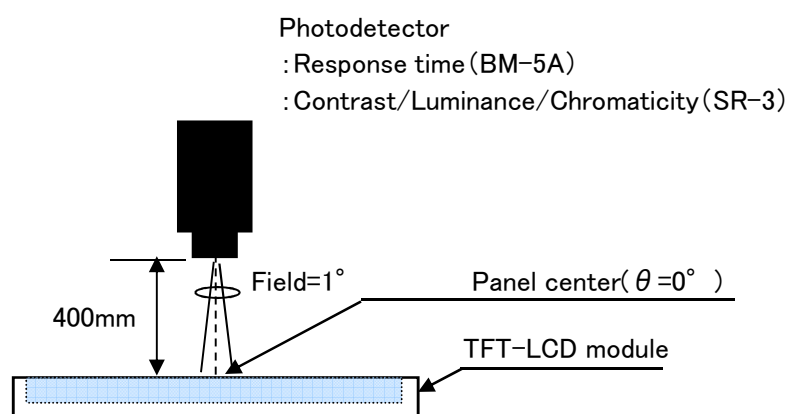
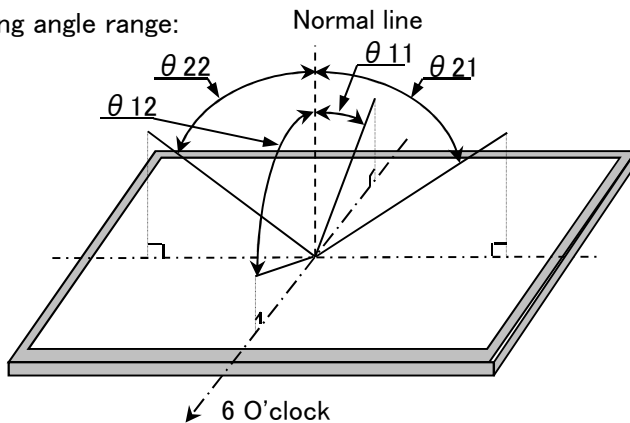

fig.2-2 Measuring method of contrast, luminance, response time, and Chromaticity.

Fig.2 Optical characteristics measurement method

【*1】Definitions of viewing angle range:



【*2】Definition of contrast ratio:

The contrast ratio is defined as the following. $Contrast (CR) = \frac{\text{Luminance with all pixels white}}{\text{Luminance with all pixels black}}$

【*3】Definition of response time:

The response time is defined as the following figure and shall be measured by switching the input signal for "black" and "white".

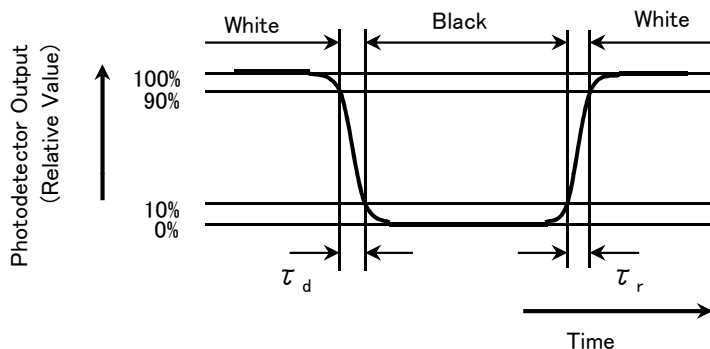

【*4】This shall be measured at center of the screen.

【*5】Definition of white uniformity:

White uniformity is defined as the following with five measurements. (①~⑤)

$$\delta_w = \frac{\text{Maximum luminance of 5 points(①~⑤)}}{\text{Minimum luminance of 5 points(①~⑤)}}$$

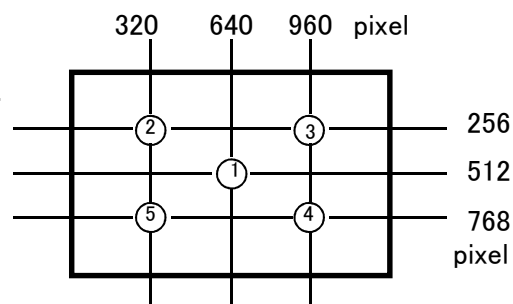

10. Handling Precautions

- a) Be sure to turn off the power supply when inserting or disconnecting the cable.
- b) Since the front polarizer is easily damaged, pay attention not to scratch it.
- c) Wipe off water drop immediately. Long contact with water may cause discoloration or spots.
- d) When the panel surface is soiled, wipe it with absorbent cotton or other soft cloth.
- e) Since the panel is made of glass, it may break or crack if dropped or bumped on hard surface.
Handle with care.
- f) Since CMOS LSI is used in this module, take care of static electricity and injure the human earth when handling. Observe all other precautionary requirements in handling components.
- g) Since there is a circuit board in the module back, stress is not added at the time of a design assembly. Please make it like. If stress is added, there is a possibility that circuit parts may be damaged.
- h) It causes an irregular display and the defective indication, etc., when always put constant pressure on the back of the module.
Please do not make the structure to press the back of the module.
- i) Do not expose the LCD panel to direct sunlight. Lightproof shade etc. should be attached when LCD panel is used under such environment.
- j) Connect GND to stabilize against EMI and external noise.
- k) When handling LCD modules and assembling them into cabinets, please avoid that long-terms storage in the environment of oxidization or deoxidization gas and the use of such materials as reagent, solvent, adhesive, resin, etc. which generate these gasses, may cause corrosion and discoloration of the modules.
Do not use the LCD module under such environment.
- l) Liquid crystal contained in the panel may leak if the LCD is broken. Rinse it as soon as possible if it gets inside your eye or mouth by mistake.
- m) Be careful when using it for long time with fixed pattern display as it may cause accidental image.
- n) Adjusting volume have been set optimally before shipment, so do not change any adjusted value.
If adjusted value is changed, the specification may not be satisfied.
- o) If a minute particle enters in the module and adheres to an optical material, it may cause display non-uniformity issue, etc. Therefore, fine-pitch filters have to be installed to cooling and inhalation hole if you intend to install a fan.
- p) The polarizer surface on the panel is treated with Anti-Glare for low reflection. In case of attaching protective board over the LCD, be careful about the optical interface fringe etc. which degrades display quality.
- q) Notice : Never take to pieces the module , because it will cause failure.
Please do not peel off the Black tape pasted to the product.
- r) An abnormal display by changing in quality of the polarizing plate might occur regardless of contact or no contact to the polarizing plate, because of epoxy resin (amine system curing agent) that comes out from the material and the packaging material used for the set side, the silicon adhesive (dealcoholization system and oxime system), and the tray blowing agents (azo-compound), etc.
Please confirm adaptability with your employed material.

11. Packing form

- a) Piling number of cartons : MAX. 5
- b) Package quantity in one carton: 5pcs
- c) Carton size(TYP): 493mm(W) × 417mm(D) × 293mm(H)
- d) Total mass of one carton filled with full modules(5pcs): 15kg

12. Reliability test items

△2 △3

No.	Test item	Conditions	Remark
1	High temperature storage test	Ambient temperature 65°C 240H	【Note1】
2	Low temperature strage test	Ambient temperature -25°C 240H	【Note1】
3	High temperature & high humidity operation test	Ambient temperature 40°C、Humidity 95% RH 240H (No condensation.)	【Note1】
4	High temperature operation test	Panel surface 65°C 240H	【Note1】
5	Low temperature operation test	Ambient temperature 0°C 240H	【Note1】
6	Vibration test (non-operating)	<Sin wave> Frequency : 10~57Hz/Vibration width (one side) : 0.076mm : 57~500Hz/Gravity : 9.8m/s ² Sweep time : 11minutes Test period : 3H(X, Y, Z direction 1H)	【Note1】
7	Shock test (non-operating)	Max. gravity: 490m/s ² Pulse width: 6ms Direction: ±X, ±Y, ±Z Test period : 1time/1direction	【Note1】
8	Electrostatic discharge test (non-operating)	Contact discharge (150pF 330Ω): non-operation=±10kV, operation=±8kV Aerial discharge (150pF 330Ω): non-operation=±20kV, operation=±15kV	【Note1】

【Note1】 Under the display quality test conditions with normal operation state, these shall be no change which may affect practical display function. (normal operation state: Temperature:15~35°C, Humidity:45~75%, Atmospheric pressure:86~106kpa)

13. Others

13-1. Lot No Label:

A) Module serial label

The label that displays SHARP·Model No.(LQ190E1LW52)·Lot No. is stuck on the back of the module.

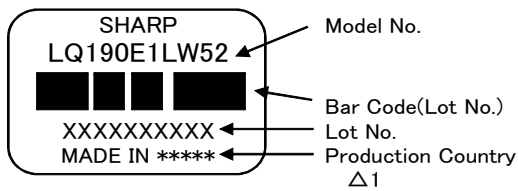

Lot No display method (Figure and alphabet)

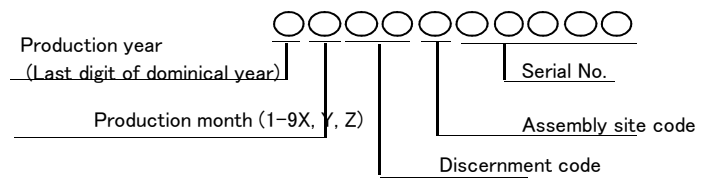

13-2. Packing box Label:

The label that displays ①Model number (LQ190E1LW52) ②Lot number ③Quantity of module is stuck on the packing box. Moreover, the display of bar code also applies to this.

Diagram of a packing box label with the following fields:

- 社内品番: (4S) LQ190E1LW52
- Barcode (①)
- Lot No. : (1T) 2011. 12. 16 * *
- Barcode (②)
- Quantity : (Q) 5 pcs
- Barcode (③)
- ユーザー品番 :
- シャープ物流用ラベルです。

- ① Model number (LQ190E1LW52)
- ② Lot number (DATA)
- ③ Quantity of module

Our management product number might be filled
(Example: LQ190E1LW52A etc.)

A right picture is written to the packing box of module for the RoHS restriction.

※ R.C. (RoHs Compliance) means these parts have corresponded with the RoHs directive.

This module corresponds from the first sample to RoHS Directive.

R.C.

The figure below is written under the SHARP logo of the packing box about the production country. △1

MADE IN JAPAN OR MADE IN CHINA

13-3. The ozone-depleting substances is not used.

13-4. If any problem occurs in relation to the description of this specification , it shall be resolved through discussion with spirit of cooperation.

14. Storage conditions

Environmental condition range of storage temperature and humidity

Temperature 0 to 40 degrees Celsius

Relative humidity 95% and below

【Note】Please refer below as a mean value of the environmental conditions.

Summer time temperature 20 to 35 degrees Celsius humidity , 85% and below

Winter time temperature 5 to 15 degrees Celsius humidity , 85% and below

Please maintain within 240 hours of accumulated length of storage time, with conditions of 40 degrees Celsius and room humidity of 95%.

Direct sun light

Please keep the product in a dark room or cover the product to protect from direct sun light.

Atmospheric condition

Please refrain from keeping the product with possible corrosive gas or volatile flux.

Prevention of dew

Please store the product carton either on a wooden pallet or a stand / rack to prevent dew.

Do not place directly on the floor. In addition, to obtain moderate ventilation in between the pallet's top and bottom surfaces, pile the cartons up in a single direction and in order.

Please place the product cartons away from the storage wall.

Storage period

Within above mentioned conditions, maximum storage period should be one year.

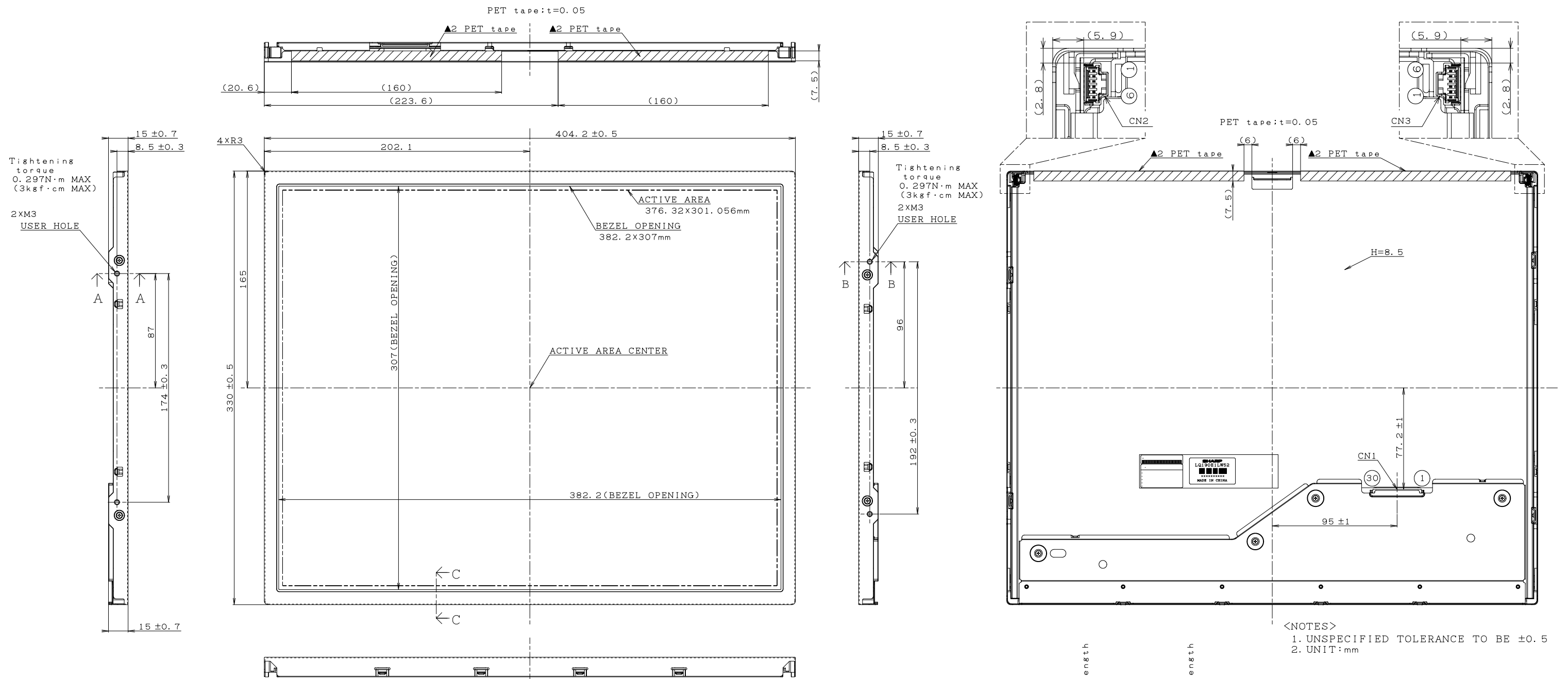

<NOTES>
1. UNSPECIFIED TOLERANCE TO BE ±0.5
2. UNIT:mm

BEZEL/DISPLAY POSITION

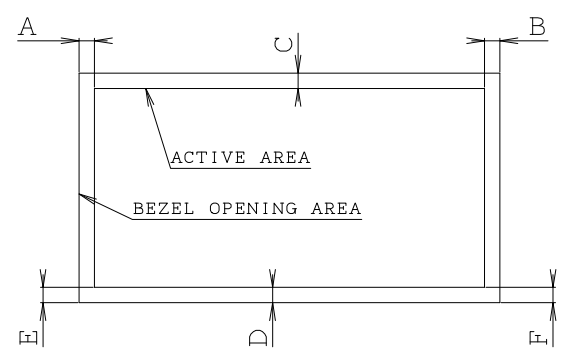

- | | |
|------------------------------|----------------|
| 1) TOLERANCE X-DIRECTION | A: 2.94 ± 0.8 |
| 2) TOLERANCE X-DIRECTION | B: 2.94 ± 0.8 |
| 3) TOLERANCE Y-DIRECTION | C: 2.972 ± 0.8 |
| 4) TOLERANCE Y-DIRECTION | D: 2.972 ± 0.8 |
| 5) OBLIQUITY OF DISPLAY AREA | E-F < 0.8 |

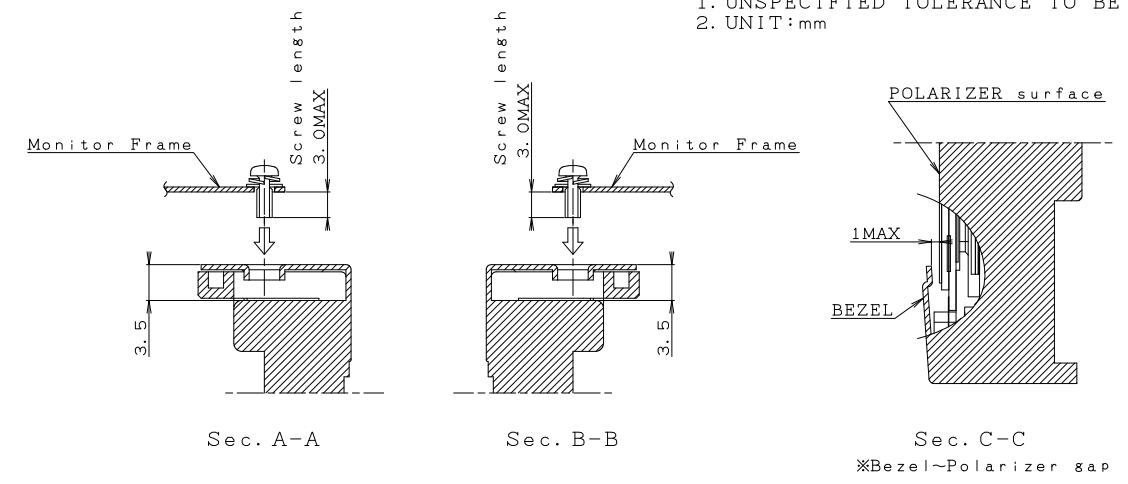

Fig. 1 Outline dimensions (LQ190E1LW52)

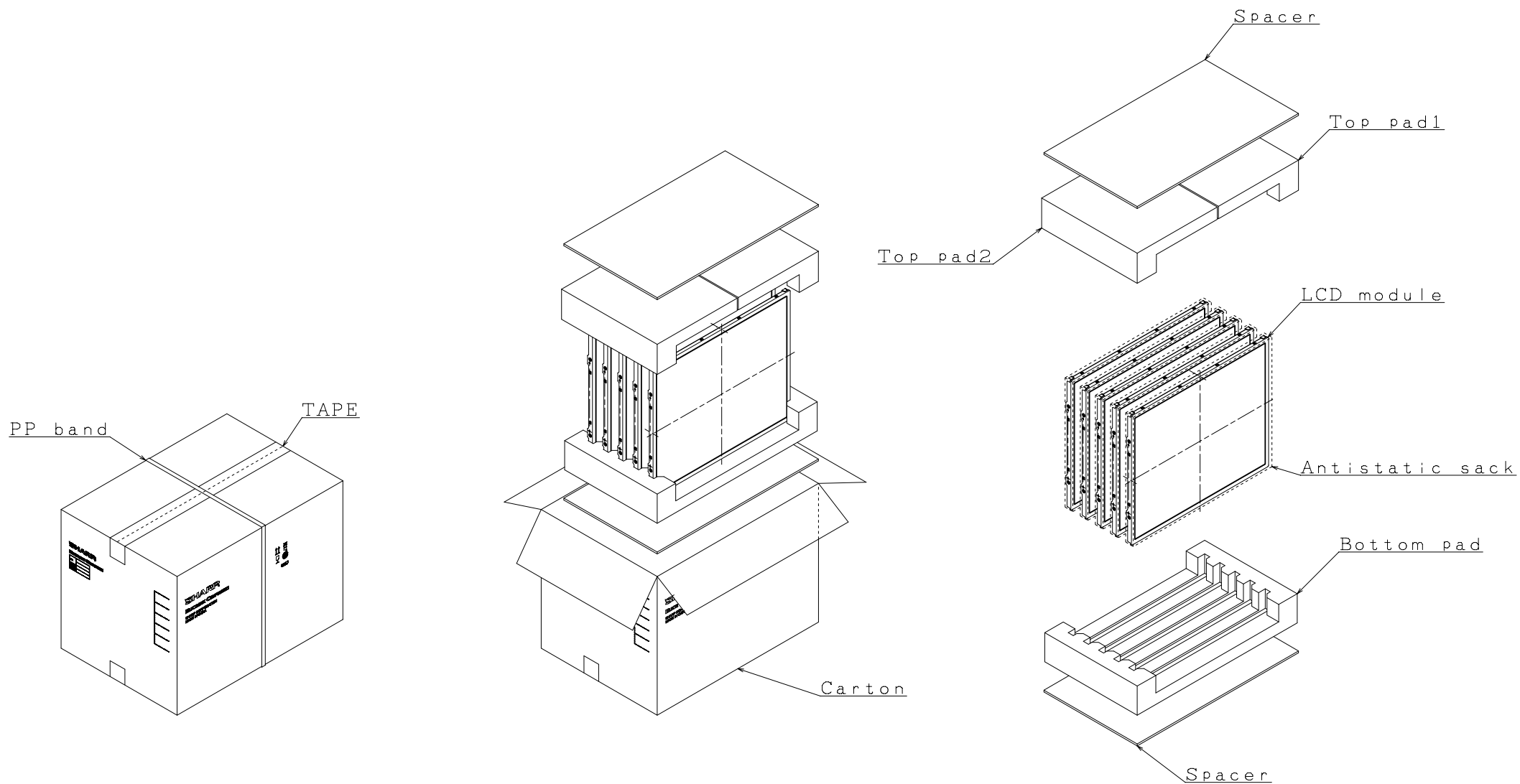

Fig3: Packing form