

SHARP

No.	LD -14150
DATE	JAN. 08 . 2002

TECHNICAL LITERATURE
FOR
TFT - LCD module

MODEL No. LQ197V3DZ31

The technical literature is subject to change without notice.
So, please contact Sharp or its representative before designing
your product based on this literature.

**DEVELOPMENT ENGINEERING DEPT.
TFT DIVISION
TFT LIQUID CRYSTAL DISPLAY GROUP
SHARP CORPORATION**

1. Application

This technical literature applies to the color 19.7" VGA TFT-LCD module LQ197V3DZ31.

- * These specification sheets are proprietary products of SHARP CORPORATION("SHARP") and include materials protected under copyright of SHARP. Do not reproduce or cause any third party to reproduce them in any form or by any means, electronic or mechanical, for any purpose, in whole or in part, without the express written permission of SHARP.
- * The device listed in these technical literature sheets was designed and manufactured for use in AV equipment.
- * In case of using the device for applications such as control and safety equipment for transportation(aircraft, trains, automobiles, etc.), rescue and security equipment and various safety related equipment which require higher reliability and safety, take into consideration that appropriate measures such as fail-safe functions and redundant system design should be taken.
- * Do not use the device for equipment that requires an extreme level of reliability, such as aerospace applications, telecommunication equipment(trunk lines), nuclear power control equipment and medical or other equipment for life support.
- * SHARP assumes no responsibility for any damage resulting from the use of the device which does not comply with the instructions and the precautions specified in these technical literature sheets.
- * Contact and consult with a SHARP sales representative for any questions about this device.

2. Overview

This module is a color active matrix LCD module incorporating amorphous silicon TFT (Thin Film Transistor). It is composed of a color TFT-LCD panel, driver ICs, control circuit, power supply circuit, inverter circuit and back light system etc. Graphics and texts can be displayed on a 640 × RGB × 480 dots panel with 262,144 colors by supplying data signal of 18 bit(6 bit x RGB), 4 kind of timing signal, +5V of DC supply voltages and supply voltage for back light.

Also, this module is include the DC/AC inverter to drive the CCFT lamps.

3. Mechanical Specifications

Parameter	Specifications	Unit
Display size	50 (Diagonal)	cm
	19.7 (Diagonal)	inch
Active area	401.28 (H) x 298.8 (V)	mm
Pixel Format	640 (H) x 480 (V) (1pixel = R + G + B dot)	pixel
Pixel pitch	0.627 (H) x 0.6225 (V)	mm
Pixel configuration	R, G, B vertical stripe	
Display mode	Normally black	
Unit Outline Dimensions *1	(462.6)(W) x (338.5)(H) x (51.6)(D)	mm
Mass	(4200)	g
Surface treatment	Anti glare, low reflection coating Hard coating : 2 H Haze : 23 +/- 5%	

(*1)Outline dimensions are shown in Fig.1

4. Input Terminals

4-1. Control circuit driving

CN3 Using connector : 34FLZX-RSM1-A-TB (JST)

(Shown in Fig.1)

Pin No.	Symbol	Function	Remarks
1	GND		
2	GND		
3	CK	Clock signal(sampling each data)	
4	Hsync	Horizontal synchronized signal	【Note 1】
5	Vsync	Vertical synchronized signal	【Note 1】
6	GND		
7	R0	Red data signal (LSB)	
8	R1	Red data signal	
9	R2	Red data signal	
10	R3	Red data signal	
11	R4	Red data signal	
12	R5	Red data signal (MSB)	
13	GND		
14	G0	Green data signal (LSB)	
15	G1	Green data signal	
16	G2	Green data signal	
17	G3	Green data signal	
18	G4	Green data signal	
19	G5	Green data signal (MSB)	
20	GND		
21	B0	Blue data signal (LSB)	
22	B1	Blue data signal	
23	B2	Blue data signal	
24	B3	Blue data signal	
25	B4	Blue data signal	
26	B5	Blue data signal (MSB)	
27	GND		
28	ENAB	Data enable signal(horizontal position)	【Note 2】
29	Vcc	+5V Power Supply	
30	Vcc	+5V Power Supply	
31	Vcc	+5V Power Supply	
32	Vcc	+5V Power Supply	
33	R/L	Reverse terminal of Right and Left	【Note 3】
34	U/D	Reverse terminal of Up and Down	【Note 3】

* Shield case contacts GND(Grand) of LCD module.

【Note 1】 The polarity combination of the Hsync.,Vsync.

Hsync	Negative
Vsync	Negative

【Note 2】 The horizontal display start timing is settled in accordance with a rising timing of ENAB signal.

In case ENAB is fixed "Low", the horizontal start timing is determined as described in 7-2.

Don't keep ENAB "High" during operation.

【Note 3】

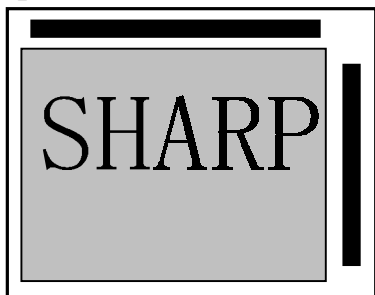

R/L : L

U/D : L

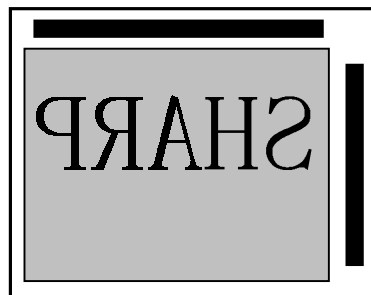

R/L : H

U/D : L



R/L : L

U/D : H



R/L : H

U/D : H

4-2. Inverter driving for back light

CN1(for inverter control) Using connector : S3B-PH-SM3-TB(JST)

Pin No.	Symbol	Function	Remark
1	V _{ON}	ON/OFF	【Note 1】
2	V _{BRT}	Brightness Control	【Note 2】
3	GND	GND	

【Note 1】 ON/OFF Function

Input voltage	Function
5V	Inverter: ON
0V	Inverter :OFF

【Note 2】 Brightness control function

Brightness control is available by 0 – 5 V analog input voltage.

Input voltage	Function
5V	Brightness Control (15%) : (Dark)
0V	Brightness Control (100%) : (Bright)

CN2 Suppling for Inverter Power Using connector : S6B-PH-SM3-TB(JST)

Pin No.	Function
1	12V
2	12V
3	12V
4	GND
5	GND
6	GND

4-3. Back light driving

The back light system is under-lighting type with 10 CCFTs(Cold Cathode Fluorescent Tube).

The characteristics of the lamp are shown in the following table. The value mentioned below is at the case of one CCFT.

Item	Symbol	Min.	Typ.	Max.	Unit	Remarks
Life time	T _L	TBD	-	-	hour	Note 1

Note 1 : Lamp life time is defined as the time when either 1 or 2 occurs in the continuous operation under the condition of Ta=25 degree and I_L=4.5mA.

1. Brightness becomes 50% of the original value under standard condition.

5. Absolute Maximum Ratings

Parameter	Symbol	Condition	Ratings	Unit	Remark
Input voltage (for Control)	V _I	Ta=25 degree	-0.3 ~ 3.6	V	Note 1
5V supply voltage (for Control)	V _{CC}	Ta=25 degree	0 ~ + 6	V	
Input voltage (for Inverter)	V _{BRT} V _{ON}	Ta=25 degree	0 ~ + 6	V	
12V supply voltage (for Inverter)	V _{INV}	Ta=25 degree	0 ~ +14	V	
Storage temperature	T _{stg}	-	-25 ~ +60	Degree	Note 2
Operation temperature (Ambient)	T _{op}	-	0 ~ +50	Degree	

Note 1 : CK, R0 ~ R5, G0 ~ G5, B0 ~ B5, Hsync, Vsync, ENAB, R/L, U/D

Note 2 : Humidity 95%RH Max.(Ta = 40 degree)

Maximum wet-bulb temperature at 39 degree of less.(Ta>40 degree)

No condensation.

6. Electrical Characteristics

6-1. Control circuit driving

Ta=25 degree

Parameter	Symbol	Min.	Typ.	Max.	Unit	Remark	
+5V supply voltage	Supply voltage	V _{CC}	+4.5	+5.0	+5.5	V	【Note 1】
	Current dissipation	I _{CC}	-	TBD	TBD	mA	【Note 2】
Permissive input ripple voltage	V _{RP}	-	-	100	mV _{P-P}	V _{CC} =+5.0V	
Input Low voltage	V _{IL}	-	-	1.0	V	【Note 3】	
Input High voltage	V _{IH}	2.3	-	-	V		
Input leak current (Low)	I _{OL1}	-	-	TBD	μA	V _I =0V 【Note 4】	
	I _{OL2}	-	-	TBD	μA	V _I =0V 【Note 5】	
Input leak current (High)	I _{OH1}	-	-	TBD	μA	V _I =V _{CC} 【Note 6】	
	I _{OH2}	-	-	TBD	μA	V _I =V _{CC} 【Note 7】	

【Note 1】

1) Input voltage sequences

$$0 < t1 \quad 10\text{ms}, 0 < t2 \quad 10\text{ms}$$

$$0 < t3 \quad 1\text{s}, t4 \quad 1\text{s}$$

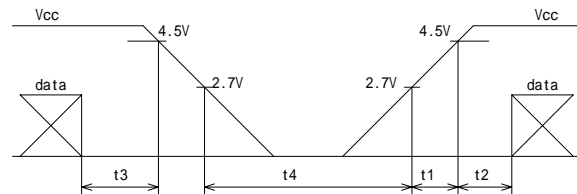

2) Dip conditions for supply voltage

a) 2.7V $V_{CC} < 4.5\text{V}$

t_d 10ms

b) $V_{CC} < 2.7\text{V}$

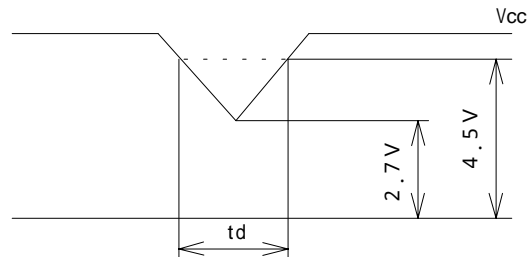

Condition of Dip conditions for supply voltage

Is based on input voltage sequence.

【Note 2】 Typical current situation : 16 gray-bar pattern(below figure 480 line mode, V_{CC}=+5.0V

The explanation of RGB gray scale see section 8.

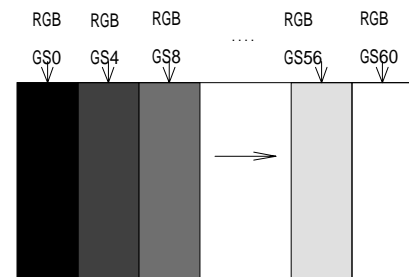

【Note 3】 CK , R0 ~ R5 , G0 ~ G5 , B0 ~ B5 , Hsync , Vsync ,
ENAB , R/L, U/D

【Note 4】 CK , R0 ~ R5 , G0 ~ G5 , B0 ~ B5 , Hsync , Vsync, ENAB

【Note 5】 R/L

【Note 6】 CK,R0 ~ R5 , G0 ~ G5 , B0 ~ B5 , Hsync , Vsync

【Note 7】 ENAB, U/D

6-2. Inver driving for back light

The back light system is under-lighting type with 10 CCFTs (Cold Cathode Fluorescent Tube)

Ta=25

Parameter	Symbol	Min.	Typ.	Max.	Unit	Remark	
+ 12V	Current dissipation	I _{INV}	TBD	(3.2)	TBD	A	V _{BRT} =0V
	Supply voltage	V _{INV}	TBD	12	TBD	V	【Note 1】
Permissible input ripple voltage	V _{RF}			TBD	mVp-p	V _{inv} = + 12V 【Note 2】	
Input voltage (Low)	V _{ONL}	-	-	TBD	V	【Note 3】	
Input voltage (High)	V _{ONH}	TBD	-	TBD	V		
Brightness control voltage	V _{BRT}	TBD	-	TBD	V	【Note 4】	
Input current (Low)	I _{OL3}	-	-	TBD	μ A	V _{ONL} =0V 【Note 3】	
	I _{OL4}	-	-	TBD	μ A	V _{BRT} =0V 【Note 4】	
Input current (High)	I _{OH3}	-	-	TBD	μ A	V _{ONH} =5V 【Note 3】	
	I _{OH4}	-	-	TBD	μ A	V _{BRT} =5V 【Note 4】	

【Note 1】 1) V_{inv}-turn-on condition

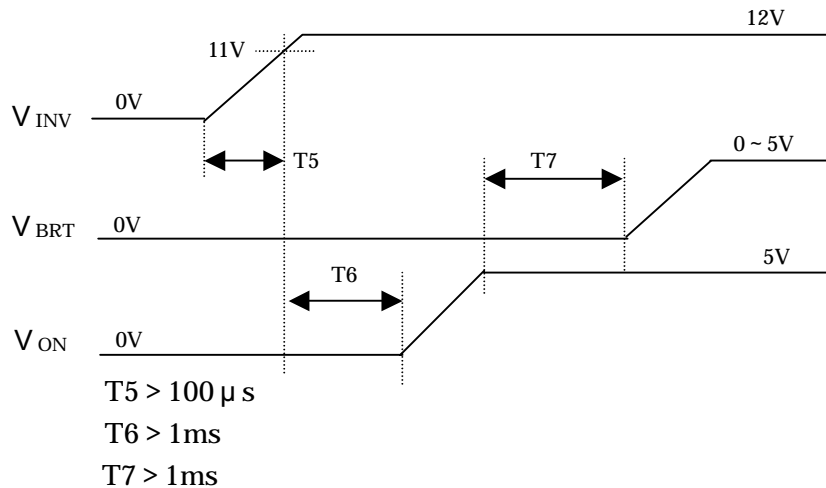

2) V_{inv}-turn-off condition

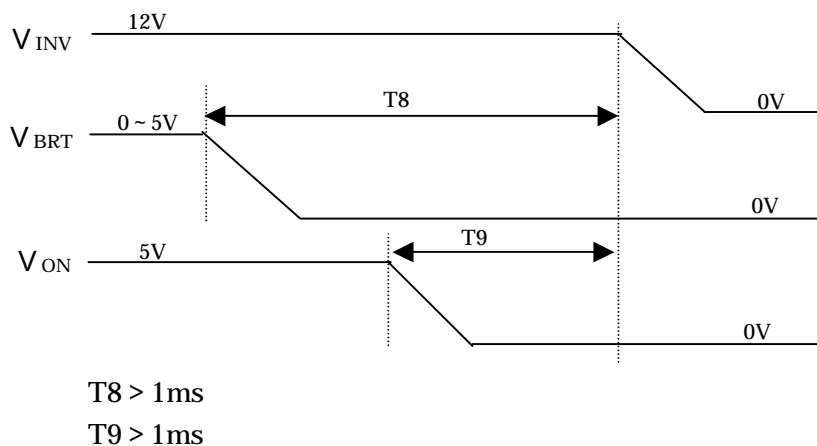

【Note 2】 V_{BRT}, V_{ON}

【Note 3】 V_{ON}

【Note 4】 V_{BRT}

7. Timing characteristics of input voltage

Timing diagrams of input signal rare shown in Fig.2

7-1. Timing characteristics

Parameter		Symbol	Min.	Typ.	Max.	Unit	Remark
Clock	Frequency	1/Tc	-	(25.2)	TBD	MHz	
	High time	Tch	5	-	-	ns	
	Low time	Tcl	10	-	-	ns	
Data	Set up time	Tds	5	-	-	ns	
	Hold time	Tdh	10	-	-	ns	
Horizontal synchronized signal	Cycle	TH	30.00	31.78	-	μ s	
			770	800	900	Clock	
	Pulse width	THp	2	96	200	Clock	
Vertical synchronized signal	Cycle	TV	515	525	560	Line	
	Pulse width	TVp	2	-	34	Line	
Horizontal display area		THd	640	640	640	Clock	
Hsync-Clock phase difference		THc	10	-	Tc-10	ns	
		TVh	0	-	TH-THp	Clock	

Note) In case of lower frequency , the deterioration of display quality , flicker etc, may be occurred.

In case of turn-off , turn-off may be after input signal for “black”.

7-2. Horizontal display position

The horizontal display position is determined by ENAB signal and the input data corresponding to the Rising edge of ENAB signal is displayed at the left end of the active area.

Parameter		Symbol	Min.	Typ.	Max.	Unit	Remark
Enable signal	Set up time	Tes	5	-	Tc-10	ns	
	Pulse width	Tep	2	640	640	Clock	
Hsync-Enable signal phase difference		THE	44	-	TH-664	Clock	

Note) When ENAB is fixed “Low”, the display starts from the data of C104(clock)as shown in Fig.2

7-3. Input data signal and display position on the screen



Display position of input data(H, V)

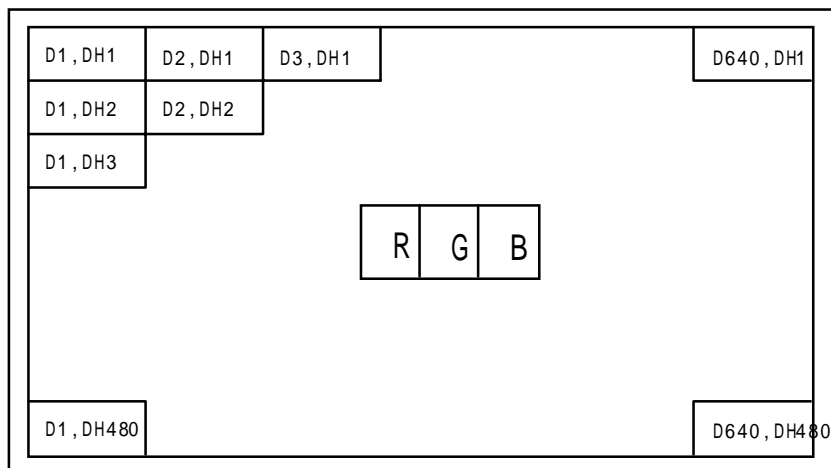

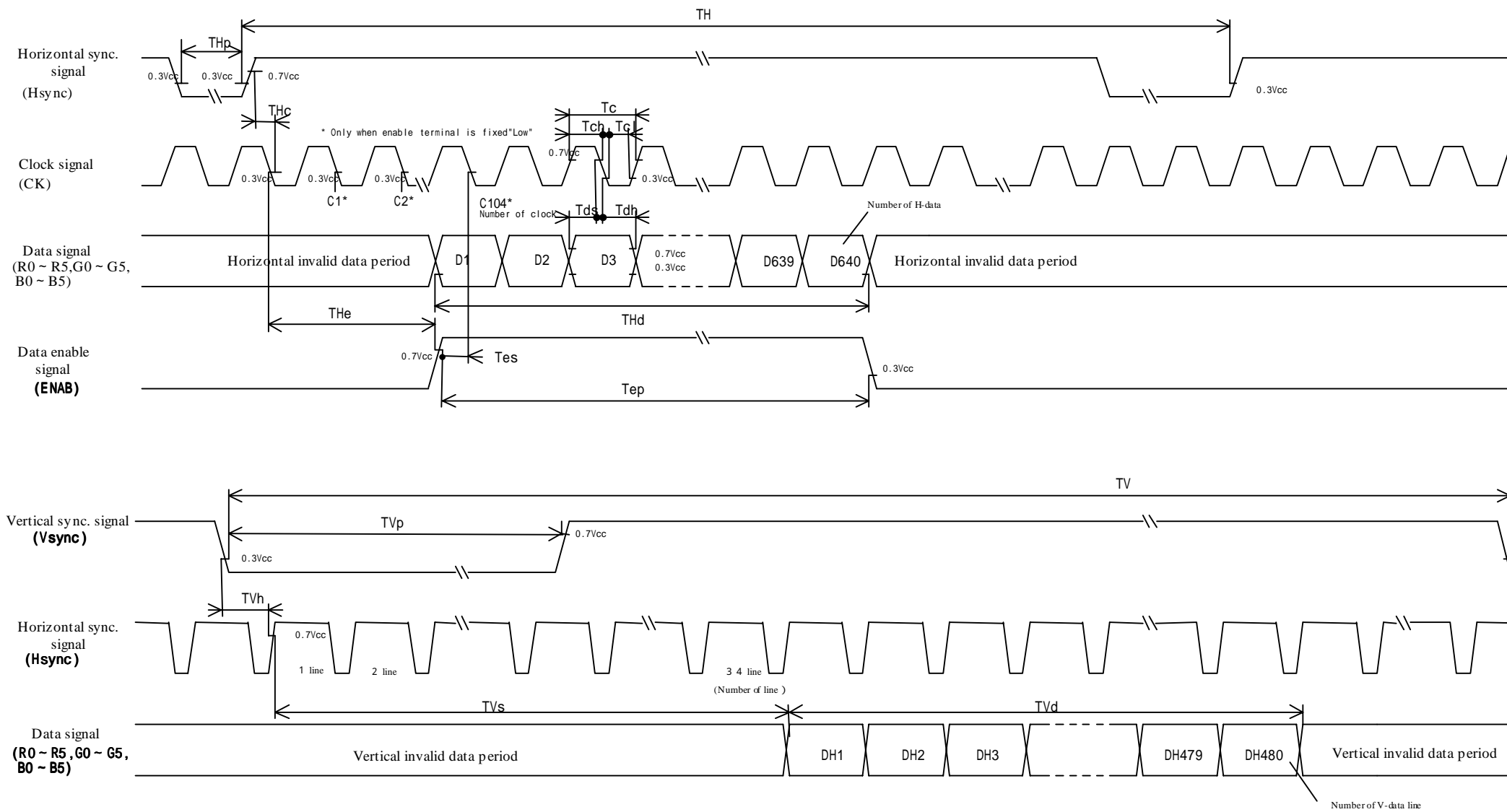

Fig.2 Input signal waveforms

8. Input Signal, Basic Display Colors and Gray Scale of Each Color

	Color & Gray scale	Data signal																		
		Gray Scale	R0	R1	R2	R3	R4	R5	G0	G1	G2	G3	G4	G5	B0	B1	B2	B3	B4	B5
Basic Color	Black	-	0	0	0	0	0	0	0	0	0	0	0	0	0	0	0	0	0	0
	Blue	-	0	0	0	0	0	0	0	0	0	0	0	0	1	1	1	1	1	1
	Green	-	0	0	0	0	0	0	1	1	1	1	1	1	0	0	0	0	0	0
	Cyan	-	0	0	0	0	0	0	1	1	1	1	1	1	1	1	1	1	1	1
	Red	-	1	1	1	1	1	1	0	0	0	0	0	0	0	0	0	0	0	0
	Magenta	-	1	1	1	1	1	1	0	0	0	0	0	0	1	1	1	1	1	1
	Yellow	-	1	1	1	1	1	1	1	1	1	1	1	1	0	0	0	0	0	0
	White	-	1	1	1	1	1	1	1	1	1	1	1	1	1	1	1	1	1	1
Gray Scale of Red	Black	GS0	0	0	0	0	0	0	0	0	0	0	0	0	0	0	0	0	0	0
	↑	GS1	1	0	0	0	0	0	0	0	0	0	0	0	0	0	0	0	0	0
	Darker	GS2	0	1	0	0	0	0	0	0	0	0	0	0	0	0	0	0	0	0
	↑	↓				↓				↓							↓			
	↓	↓				↓				↓							↓			
	Brighter	GS61	1	0	1	1	1	1	0	0	0	0	0	0	0	0	0	0	0	0
	↓	GS62	0	1	1	1	1	1	0	0	0	0	0	0	0	0	0	0	0	0
Red	GS63	1	1	1	1	1	1	0	0	0	0	0	0	0	0	0	0	0	0	
Gray Scale of Green	Black	GS0	0	0	0	0	0	0	0	0	0	0	0	0	0	0	0	0	0	0
	↑	GS1	0	0	0	0	0	0	1	0	0	0	0	0	0	0	0	0	0	0
	Darker	GS2	0	0	0	0	0	0	0	1	0	0	0	0	0	0	0	0	0	0
	↑	↓				↓				↓							↓			
	↓	↓				↓				↓							↓			
	Brighter	GS61	0	0	0	0	0	0	1	0	1	1	1	1	0	0	0	0	0	0
	↓	GS62	0	0	0	0	0	0	0	1	1	1	1	1	0	0	0	0	0	0
Green	GS63	0	0	0	0	0	0	1	1	1	1	1	1	0	0	0	0	0	0	
Gray Scale of Blue	Black	GS0	0	0	0	0	0	0	0	0	0	0	0	0	0	0	0	0	0	0
	↑	GS1	0	0	0	0	0	0	0	0	0	0	0	1	0	0	0	0	0	0
	Darker	GS2	0	0	0	0	0	0	0	0	0	0	0	0	0	1	0	0	0	0
	↑	↓				↓				↓						↓				
	↓	↓				↓				↓						↓				
	Brighter	GS61	0	0	0	0	0	0	0	0	0	0	0	0	1	0	1	1	1	1
	↓	GS62	0	0	0	0	0	0	0	0	0	0	0	0	0	1	1	1	1	1
Blue	GS63	0	0	0	0	0	0	0	0	0	0	0	0	1	1	1	1	1	1	

0 : Low level voltage 1 : High level voltage

Each basic color can be displayed in 64 gray scales from 6 bit data signals. According to the combination of total 18 bit data signals, the 262,144 color display can be achieved on the screen.

9. Optical characteristics

Ta=25 degree, Vcc=+5V , Vinv= + 12V

Parameter	Symbol	Condition	Min.	Typ.	Max.	Unit	Remark
Viewing angle range	Horizontal	CR 10	TBD	85	-	Deg.	【Note1,4】
	Vertical		TBD	85	-	Deg.	
Contrast ratio	CRn	Best Viewing Angle	-	500	-		【Note2,4】
Response time	Rise	=0 deg.	-	(10)	TBD	ms	【Note3,4】
	Decay		-	(15)	TBD	ms	
Chromaticity of white	X		-	TBD	-	-	【Note 4】
	Y		-	TBD	-	-	
Luminance of white	YL1		-	(420)	-	cd/m2	V _{BRT} =0V 【Note 4】
Luminance uniformity	w		-	-	TBD		【Note 5】

*The measurement shall be executed 30 minutes after lighting at rating.

【Note 1】 Definitions of viewing angle range :

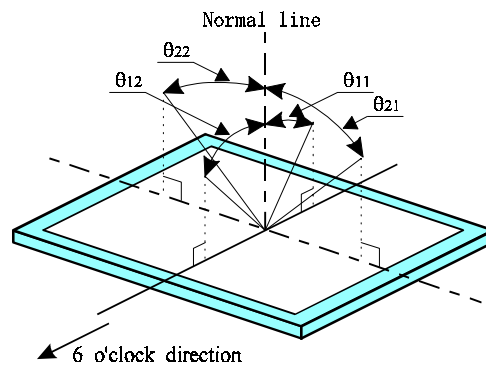

【Note 2】 Definition of contrast ratio :

The contrast ratio is defined as the following.

$$\text{Contrast Ratio (CR)} = \frac{\text{Luminance(brightness) with all pixels white}}{\text{Luminance(brightness) with all pixels black}}$$

【Note 3】 Definition of response time

The response time is defined as the following figure and shall be measured by switching the input signal for “black” and “white”.

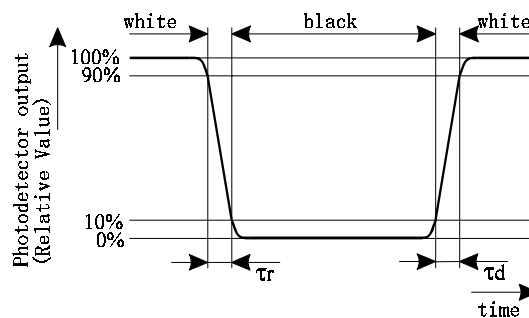

【Note 4】 This shall be measured at center of the screen.

【Note 5】 Definition of white uniformity ;

White uniformity is defined as the following with five measurements.(A ~ E)

$$w = \frac{\text{maximum Luminance of five points(brightness)}}{\text{minimum Luminance of five points(brightness)}}$$

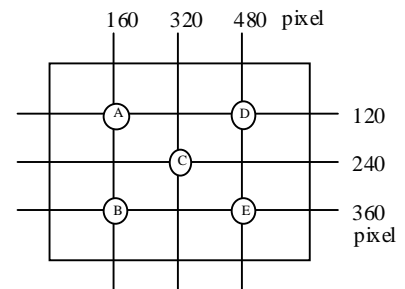
**10. Display Quantity**

The display quality of the color TFT-LCD module shall be in compliance with the incoming inspection Standard.

11. Handling Precautions of the module

- a) Be sure to turn off the power supply when inserting or disconnecting the cable.
- b) Be sure to design the cabinet so that the module can be installed without any extra stress such as warp or twist.
- c) Since the front polarizer is easily damaged, pay attention not to scratch it.
- d) Since long contact with water may cause discoloration or spots, wipe off water drop immediately.
- e) When the panel surface is soiled, wipe it with absorbent cotton or other soft cloth.
- f) Since the panel is made of glass, it may break or crack if dropped or bumped on hard surface. Handle with care.
- g) Since CMOS LSI is used in this module, take care of static electricity and take the human earth into consideration when handling.
- h) The module has some printed circuit boards (PCBs) on the back side, take care to keep them from any stress or pressure when handling or installing the module; otherwise some of electronic parts on the PCBs may be damaged.
- i) Observe all other precautionary requirements in handling components.
- j) When some pressure is added onto the module from rear side constantly, it causes display non-uniformity issue, functional defect, etc. So, please avoid such design.
- k) When giving a touch to the panel at power supply, it may cause some kinds of degradation. In that case, once turn off the power supply, and turn on after several seconds again, and that is disappear.
- l) When handling LCD modules and assembling them into cabinets, please be noted that long-term storage in the environment of oxidization or deoxidization gas and the use of such materials as reagent, solvent, adhesive, resin, etc. which generate these gasses, may cause corrosion and discoloration of the LCD modules.

12. Packing form

- a) Piling number of cartons : maximum TBD
- b) Packing quantity in one carton : TBD
- c) Carton size : TBD
- d) Total mass of one carton filled with full modules : TBD

13. Reliability test items

No.	Test item	Conditions
1	High temperature storage test	Ta= 60 240h
2	Low temperature storage test	Ta= - 25 240h
3	High temperature and high humidity operation test	Ta= 40 ; 95%RH 240h (No condensation)
4	High temperature operation test	Ta= 50 240h
5	Low temperature operation test	Ta= 0 240h
6	Vibration test (non-operation)	Frequency : 10 ~ 57Hz/Vibration width(one side) : 0.075mm : 58 ~ 500Hz/Gravity : 9.8m/s ² Sweep time: 11 minutes Test period : 3 hours(1h for each direction of X, Y, Z)
7	Shock test (non-operation)	Max. gravity : 490m/s ² Pulse width : 11ms, sine wave Direction : +/-X, +/-Y, +/-Z, once for each direction.

【Result evaluation criteria】

Under the display quality test conditions with normal operation state, these shall be no change which may affect practical display function.

14. Others

1) Lot No. Label;

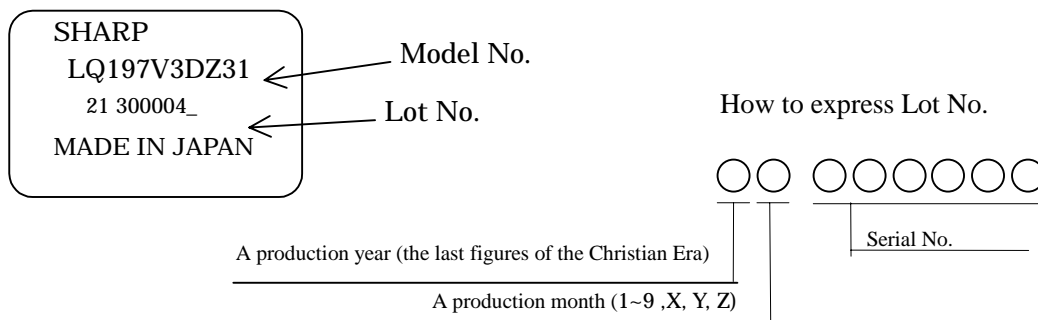

- 2) Adjusting volume have been set optimally before shipment, so do not change any adjusted value. If adjusted value is changed, the specification may not be satisfied.
- 3) Disassembling the module can cause permanent damage and should be strictly avoided.
- 4) Please be careful since image retention may occur when a fixed pattern is displayed for a long time.
- 5) When any question or issue occurs, it shall be solved by mutual discussion.

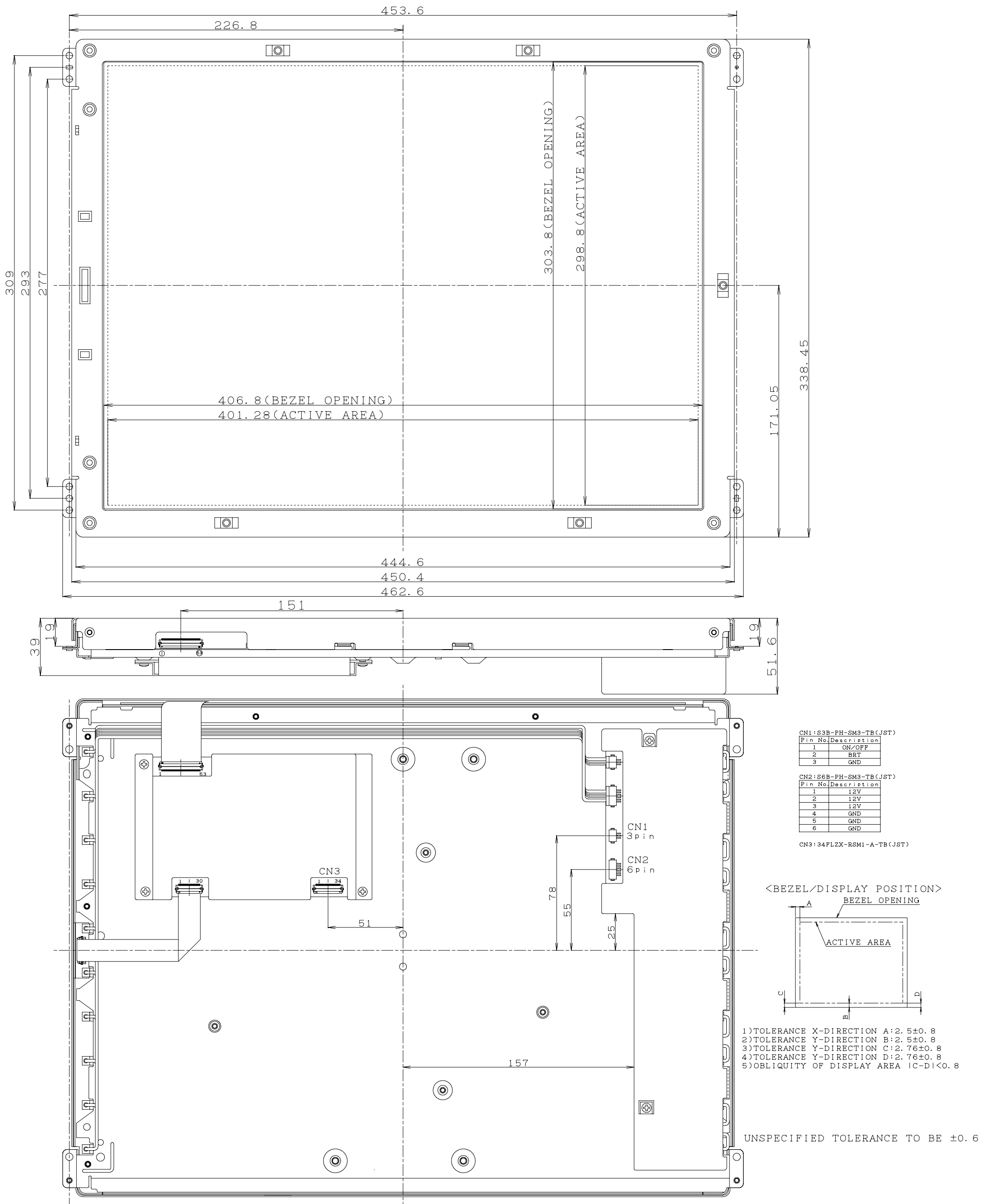

FIG. 1 OUTLINE DIMENSIONS (LQ197V3DZ31)
TENTATIVE