

PREPARED BY :    DATE	<b>SHARP</b>	SPEC No. LD-21034
		FILE No.
		ISSUE : Mar.17.2009
APPROVED BY :    DATE	Mobile LIQUID CRYSTAL DISPLAY GROUP SHARP CORPORATION	PAGE : 23 pages
		APPLICABLE GROUP Mobile Liquid Crystal Display Group
	<b>SPECIFICATION</b>	

DEVICE SPECIFICATION  
**TFT-LCD Module**  
 MODEL  
**LQ201U1LW22**

**These parts have corresponded with the RoHS directive.**

CUSTOMER'S APPROVAL

DATE \_\_\_\_\_

BY \_\_\_\_\_

PRESENTED

BY *T. Naka*

T.NAKA  
 DIVISION DEPUTY GENERAL MANAGER  
 AND DEPARTMENT GENERAL MANAGER  
 ENGINEERING DEPT. I  
 MOBILE LIQUID CRYSTAL DISPLAY DIVISION III  
 MOBILE LIQUID CRYSTAL DISPLAY GROUP



## 1. Application

This specification applies to the color 20.1 UXGA TFT-LCD module LQ201U1LW22.

- ◎These specification sheets are the proprietary product of SHARP CORPORATION("SHARP) and include materials protected under copyright of SHARP. Do not reproduce or cause any third party to reproduce them in any form or by any means, electronic or mechanical, for any purpose, in whole or in part, without the express written permission of SHARP.
- ◎The device listed in these specification sheets was designed and manufactured for use in OA equipment.
- ◎In case of using the device for applications such as control and safety equipment for transportation(aircraft, trains, automobiles, etc. ), rescue and security equipment and various safety related equipment which require higher reliability and safety, take into consideration that appropriate measures such as fail-safe functions and redundant system design should be taken.
- ◎Do not use the device for equipment that requires an extreme level of reliability, such as aerospace applications, telecommunication equipment (trunk lines), nuclear power control equipment and medical or other equipment for life support.
- ◎SHARP assumes no responsibility for any damage resulting from the use of the device which does not comply with the instructions and the precautions specified in these specification sheets.
- ◎Contact and consult with a SHARP sales representative for any questions about this device.

## 2. Overview

This module is a color active matrix LCD module incorporating amorphous silicon TFT (Thin Film Transistor). It is composed of a color TFT-LCD panel, driver ICs, control circuit, power supply circuit and a back light unit. Graphics and texts can be displayed on a 1600×3×1200 dots panel with about 16 million colors by supplying 48 bit data signals(8bit×2pixel×RGB) , two display enable signals, two dot clock signals, +12V DC supply voltages for TFT-LCD panel driving and supply voltage for back light.

It is a wide viewing-angle-module (Vertical viewing angle:176° Horizontal viewing angle:176° ,CR≥10). This module performance achieve 20ms response time (full; black to white, or white to black) done by improving Liquid crystal material.

### 3. Mechanical Specifications

Parameter	Specifications	Unit
Display size	51 (Diagonal)	cm
	20.1 (Diagonal)	Inch
Active area	408.0 (H)×306.0 (V)	mm
Pixel format	1600 (H)×1200 (V)	Pixel
	(1 pixel=R+G+B dots)	
Pixel pitch	0.255(H)×0.255 (V)	mm
Pixel configuration	R,G,B vertical stripe	
Display mode	Normally black	
Unit outline dimensions	432(W)×331.5 (H)×25 (D)	mm
Mass	3.2 (Typ)	kg
Surface treatment	Anti-glare And hard-coating 3H	

Outline dimensions are shown in Fig.1.

#### 4. Input Terminals and Function

##### 4-1. TFT-LCD panel driving

LVDS interface with 2 input signal, and +12VDC power supply, control signal

Connectors: MDF76LARW-30S-1H (HIROSE) or FI-XB30SRL-HF11 (JAE)

Corresponding connectors: FI-X30M (JAE)

LVDS receiver : Contained in a control IC

Corresponding LVDS transmitter : THC63LVDM83R(Thine) or compatible

Pin No.	Symbol	Function	Remark
1	Vcc	+12V power supply	
2	Vcc	+12V power supply	
3	Vcc	+12V power supply	
4	Vcc	+12V power supply	
5	Vss	Gnd	
6	Vss	Gnd	
7	RBIN3+	Positive (+) LVDS differential data input (B port)	LVDS
8	RBIN3-	Negative (-) LVDS differential data input (B port)	LVDS
9	CKBIN+	Positive (+) LVDS differential clock input (B port)	LVDS
10	CKBIN-	Negative (-) LVDS differential clock input (B port)	LVDS
11	RBIN2+	Positive (+) LVDS differential data input (B port)	LVDS
12	RBIN2-	Negative (-) LVDS differential data input (B port)	LVDS
13	RBIN1+	Positive (+) LVDS differential data input (B port)	LVDS
14	RBIN1-	Negative (-) LVDS differential data input (B port)	LVDS
15	RBIN0+	Positive (+) LVDS differential data input (B port)	LVDS
16	RBIN0-	Negative (-) LVDS differential data input (B port)	LVDS
17	Vss	Gnd	
18	Vss	Gnd	
19	RAIN3+	Positive (+) LVDS differential data input (A port)	LVDS
20	RAIN3-	Negative (-) LVDS differential data input (A port)	LVDS
21	CKAIN+	Positive (+) LVDS differential clock input (A port)	LVDS
22	CKAIN-	Negative (-) LVDS differential clock input (A port)	LVDS
23	RAIN2+	Positive (+) LVDS differential data input (A port)	LVDS
24	RAIN2-	Negative (-) LVDS differential data input (A port)	LVDS
25	RAIN1+	Positive (+) LVDS differential data input (A port)	LVDS
26	RAIN1-	Negative (-) LVDS differential data input (A port)	LVDS
27	RAIN0+	Positive (+) LVDS differential data input (A port)	LVDS
28	RAIN0-	Negative (-) LVDS differential data input (A port)	LVDS
29	Vss	Gnd	
30	SELLVDS	Select LVDS data order 【Note1】	Pull Up

【Note1】 This module has dual pixel port to receive dual pixel data at the same time . A port receives first pixel data and B port receives second pixel data in dual pixel data.

## 【Note1】SELLVDS (Thine:THC63LVDM83R)

Transmitter		SELLVDS	
Pin No	Data	Low (=GND)	High (=3.0V or Open)
51	TA0	R0(LSB)	R2
52	TA1	R1	R3
54	TA2	R2	R4
55	TA3	R3	R5
56	TA4	R4	R6
3	TA5	R5	R7(MSB)
4	TA6	G0(LSB)	G2
6	TB0	G1	G3
7	TB1	G2	G4
11	TB2	G3	G5
12	TB3	G4	G6
14	TB4	G5	G7(MSB)
15	TB5	B0(LSB)	B2
19	TB6	B1	B3
20	TC0	B2	B4
22	TC1	B3	B5
23	TC2	B4	B6
24	TC3	B5	B7(MSB)
27	TC4	(NA)	(NA)
28	TC5	(RSV1)	(RSV1)
30	TC6	DE	DE
50	TD0	R6	R0(LSB)
2	TD1	R7(MSB)	R1
8	TD2	G6	G0(LSB)
10	TD3	G7(MSB)	G1
16	TD4	B6	B0(LSB)
18	TD5	B7(MSB)	B1
25	TD6	(NA)	(NA)

## 4-2 Interface block diagram

LVDS receiver : Contained in a control IC.

Applied Transmitter : TH63LVDM83R(THine electronics), or equivalent: DS90C383,DS90C383A(National semiconductor)

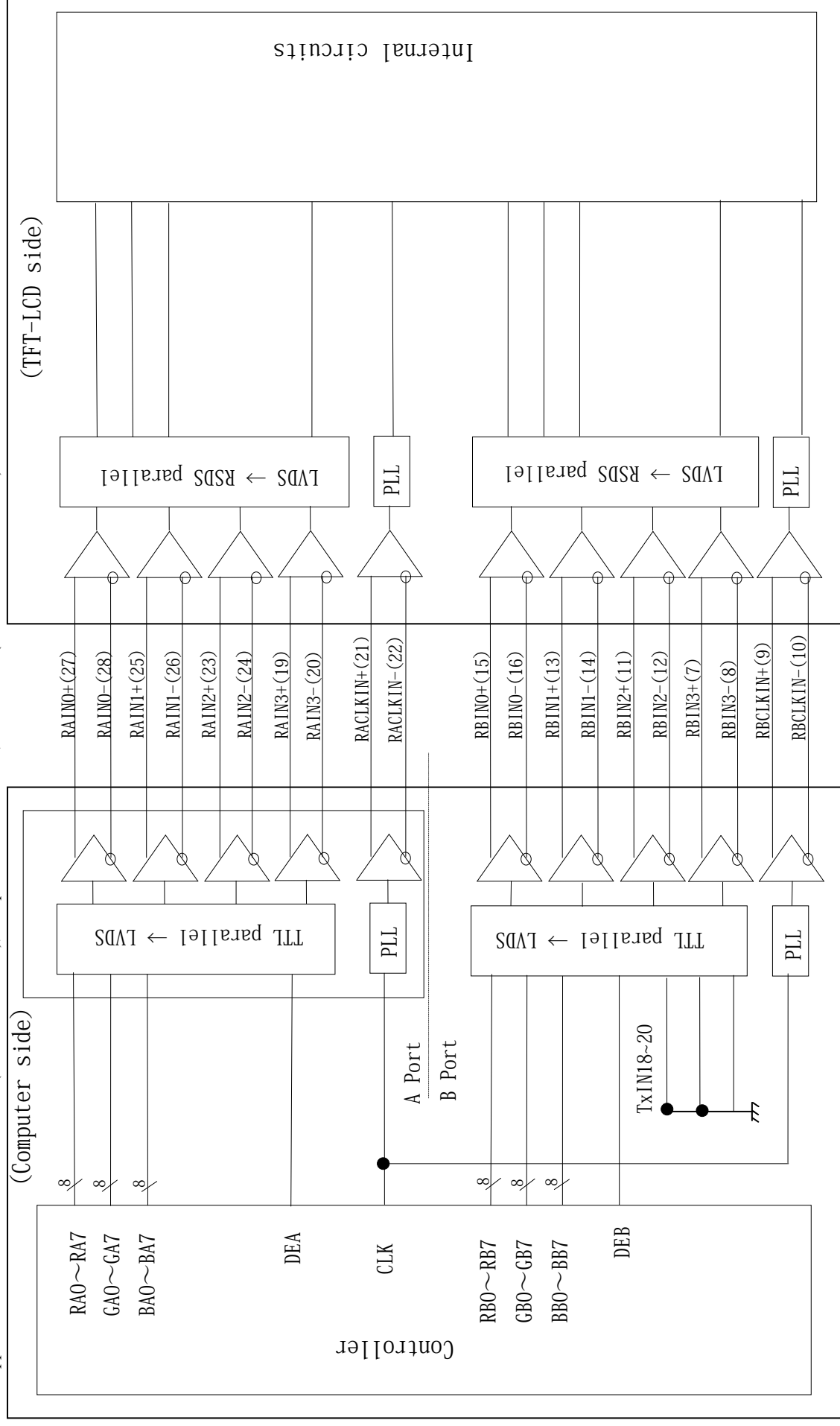

## 4-2. Back light driving

CN1, 3 (High voltage side)

The module-side connector: XHP-7 (JST)

The user-side connector: S7B-XH-A (JST)

Cable: UL Style No.: 10267  
 rated voltage: 2kV (AC)  
 AWG: 26

Pin no.	symbol	Function	Cable color
1	$V_{H-1}$	Power supply for lamp 1 (High voltage side)	Pink
2	NC	This is electrically opened.	
3	NC	This is electrically opened.	
4	$V_{H-2}$	Power supply for lamp 2 (High voltage side)	Blue
5	NC	This is electrically opened.	
6	NC	This is electrically opened.	
7	$V_{H-3}$	Power supply for lamp 3 (High voltage side)	Orange

CN 2,4(Low voltage side)

The module-side connector: BHR-03VS-1 (JST)

The user-side connector: SM03(4.0)B-BHS-1-TB (JST)

Cable: UL Style No.: 10368  
 rated voltage: 300V (AC)  
 AWG: 26

Pin no.	symbol	Function	Cable color
1	$V_{L-1}$	Power supply for lamp 1 (Low voltage side)	White
2	$V_{L-2}$	Power supply for lamp 2 (Low voltage side)	Gray
3	$V_{L-3}$	Power supply for lamp 3 (Low voltage side)	Brown

The pair of CN1 and CN2 is for the same CCFT lamps. The pair of CN3 and CN4 is in the same way.

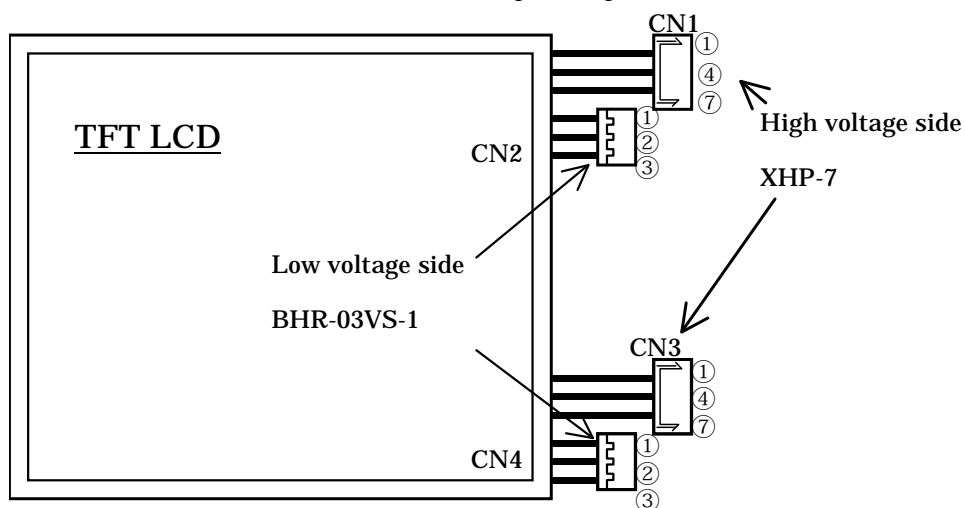

## 5. Absolute Maximum Ratings

Parameter	Symbol	Condition	Ratings	Unit	Remark
+12.0V supply voltage	Vcc	Ta=25°C	0 ~ +14.0	V	
Storage temperature	Tstg	—	-25 ~ +60	°C	【Note1】
Operating temperature (Ambient)	Topa	—	0 ~ +50	°C	

【Note1】 Humidity : 95%RH Max. ( Ta ≤ 40°C )

Maximum wet-bulb temperature at 39°C or less. ( Ta &gt; 40°C )

No condensation.



6. Electrical Characteristics

6-1. TFT-LCD panel driving

Ta=25°C

Parameter		Symbol	Min.	Typ.	Max.	Unit	Remark
Vcc	Supply voltage	Vcc	+10.8	+12.0	+13.2	V	【Note1】
	Current dissipation	Icc	—	420	600	mA	【Note2】
	Rush Current				3	A	【Note3】
Permissive input ripple voltage		V <sub>RF</sub>	—	—	100	mVp-p	
Input voltage (Low)		V <sub>IL</sub>	0	—	+0.6	V	SELLVDS
Input voltage (High)		V <sub>IH</sub>	+2.7	—	+3.3	V	SELLVDS
Input current (Low)		I <sub>IL</sub>	—	—	500	μA	V <sub>I</sub> =GND
Input current (High)		I <sub>IH</sub>	—	—	10	μA	V <sub>I</sub> =Vcc

【Note1】

1) On-off sequences of Vcc and data

- 0 < t1 ≤ 60ms
- 0 < t2 ≤ 10ms
- 0 ≤ t3 ≤ 1s
- t4 ≥ 100ms

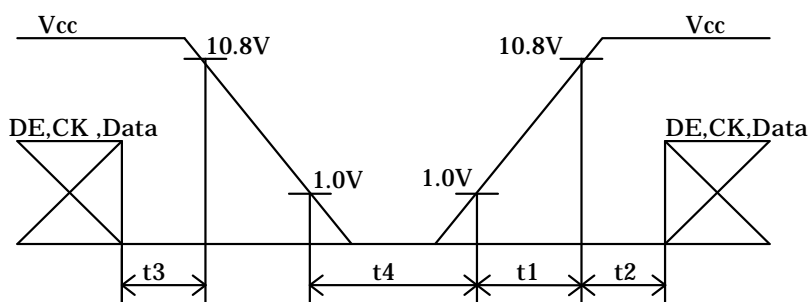

2) Dip conditions for supply voltage

V<sub>min</sub>, V<sub>th</sub> = 10.8V, 9.6V

- 1) V<sub>th</sub> ≤ Vcc < V<sub>min</sub>  
td ≤ 20ms
- 2) Vcc < V<sub>th</sub>

The LCD module shuts down.

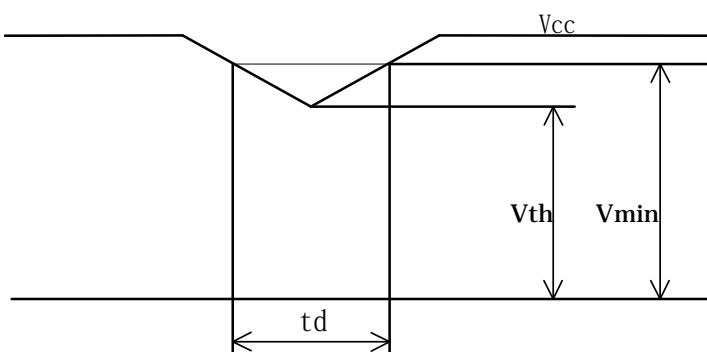

【Note2】 Typical current situation : 256-gray-bar pattern

Vcc = +12.0V

The explanation of each gray scale ,GS,  
is described below section 8.

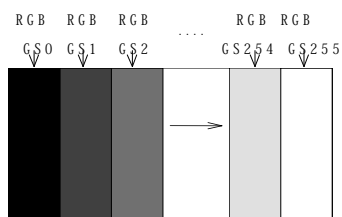

【Note3】 The duration of rush current is about 1ms.

## 6-2. Back light driving

The back light system is an edge-lighting type with 6 CCFTs (Cold Cathode Fluorescent Tube).

The characteristics of the lamp are shown in the following table.

The value mentioned below is at the case of one CCFT.

CCFT Model Name : KTBE222MSTF-421MA77-Z (STANLEY.ELECTRIC.CO.,LTD)

Parameter	Symbol	Min.	Typ.	Max.	Unit	Remark
Lamp current range	$I_L$	3	6	7	mArms	【Note1】
Lamp voltage	$V_L$		800	900	Vrms	$T_a=25^\circ\text{C}$ $I_L=6.0\text{mA}_{\text{rms}}$ $F_L=60\text{kHz}$
Lamp power consumption	$P_L$		4.8	5.4	W	【Note2】 $I_L=6.0\text{mA}_{\text{rms}}$ $F_L=60\text{kHz}$
Lamp frequency	$F_L$	35	60	70	KHz	【Note3】
Kick-off voltage	$V_s$			1800	Vrms	$T_a=25^\circ\text{C}$ 【Note4】
				2000	Vrms	$T_a=0^\circ\text{C}$ 【Note4】
Lamp life time	$T_L$	50,000			Hour	【Note5】

【Note1】 A lamp can be light in the range of lamp current shown above.

Maximum rating for current is measured by high frequency current measurement equipment connected to  $V_{\text{LOW}}$  at circuit showed below.

(Note : To keep enough kick-off voltage and necessary steady voltage for CCFT.)

Lamp frequency : 35~70kHz

Ambient temperature : 0~50°C

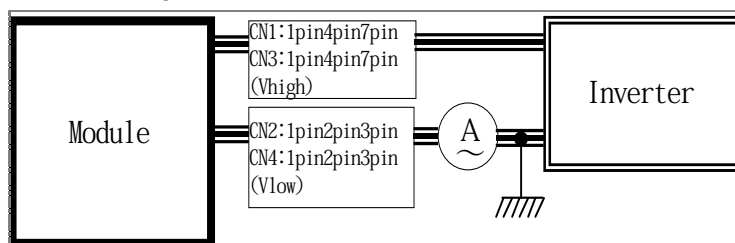

【Note2】 Referential data per one CCFT by calculation ( $I_L \times V_L$ ).

The data doesn't include loss at inverter .

【Note3】 Lamp frequency of inverter may produce interference with horizontal synchronous frequency, and this may cause horizontal beat on the display. Therefore, adjust lamp frequency, and keep inverter as far as from module or use electronic shielding between inverter and module to avoid interference.

【Note4】 It is defined at 27pF for the ballast capacitor of a DC-AC inveter.

The Kick-off voltage may rise up in the user set, please decide the open output voltage by checking not to occur lighting failure under operating state.

The open output voltage should be applied to the lamp for more than 1 second to startup. Or when the ambient luminance around the lamp is more than 1lux, it should be applied to the lamp for more than 100ms. Otherwise the lamp may not be turned on..

【Note5】 Lamp life time is defined as the time when either ① or ② occurs in the continuous operation under the condition of  $T_a=25^\circ\text{C}$  and  $I_L=6.0\text{ mArms}$  .

① Brightness becomes 50% of the original value under standard condition.

② Kick-off voltage at  $T_a=0^\circ\text{C}$  exceeds maximum value, 2000Vrms .

(Lamp lifetime may vary if lamp is in portrait position due to the change of mercury density inside the lamp.)

In case of operating under lower temp environment, the lamp exhaustion is accelerated and the brightness becomes lower. (Continuous operating for around 1 month under lower temp condition may reduce the brightness to half of the original brightness.)

In case of such usage under lower temp environment, periodical lamp exchange is recommended.

[Note6] The performance of the backlight, for example life time or brightness, is much influenced by the characteristics of the DC-AC inverter for the lamp. When you design or order the inverter, please make sure that a poor lighting caused by the mismatch of the backlight and the inverter (miss-lighting, flicker, etc.) never occur. When you confirm it, the module should be operated in the same condition as it is installed in your instrument.

Be sure to use a back light power supply with the safety protection circuit such as the detection circuit for the excess voltage, excess current and or electric discharge waveform.

Be sure to use the detect circuit by which one side of the CCFT lamps can be controlled independently. Otherwise, when one side of the CCFT is open, the excess current may possibly be applied to the other side of the lamp.

[Note7] It is required to have the inverter designed so that to allow the impedance deviation of the two CCFT lamps and the capacity deviation of barast capacitor.

[Note8] Under the environment of 10lx or less, miss-lighting or lighting delay may occur.

## 7. Timing characteristics of input signals

### 7-1. Timing characteristics

	Parameter	Symbol	Min.	Typ.	Max.	Unit	Remark
Clock	Frequency	$1/T_c$	60.0	81.0	85.0	MHz	
	Skew	$T_{csq}$	-4	0	4	ns	【Note1】
Data enable signal	Horizontal period	TH	830	1080	1317	clock	
			10.0	13.3	15.5	$\mu s$	
	Horizontal period (High)	THd	800	800	800	clock	
	Vertical period	TV	1205	1250	2000	line	【Note2】
			12.1	16.7	—	ms	
Vertical period (High)	TVd	1200	1200	1200	line		

【Note1】 Lvds (A port)– Lvds (B port) phase difference

【Note2】 In case of using the long vertical period, the deterioration of display quality, flicker etc. may occur.

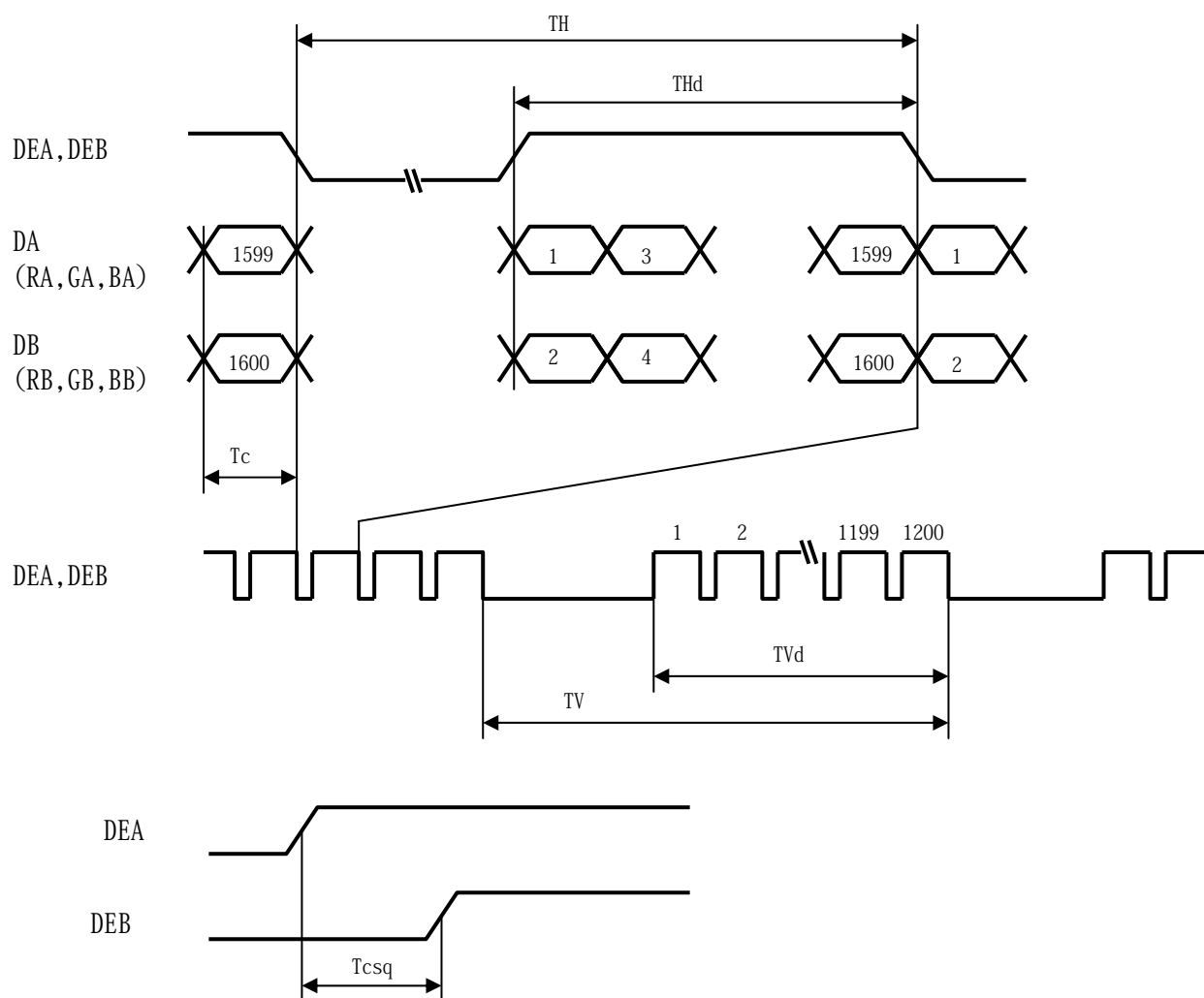

## 7-2 Input Data Signals and Display Position on the screen

Graphics and texts can be displayed on a  $1600 \times 3 \times 1200$  dots panel with 16M colors by supplying 48 bit data signal (8bit/color [256 gray scales]  $\times 3 \times 2$  pixels).

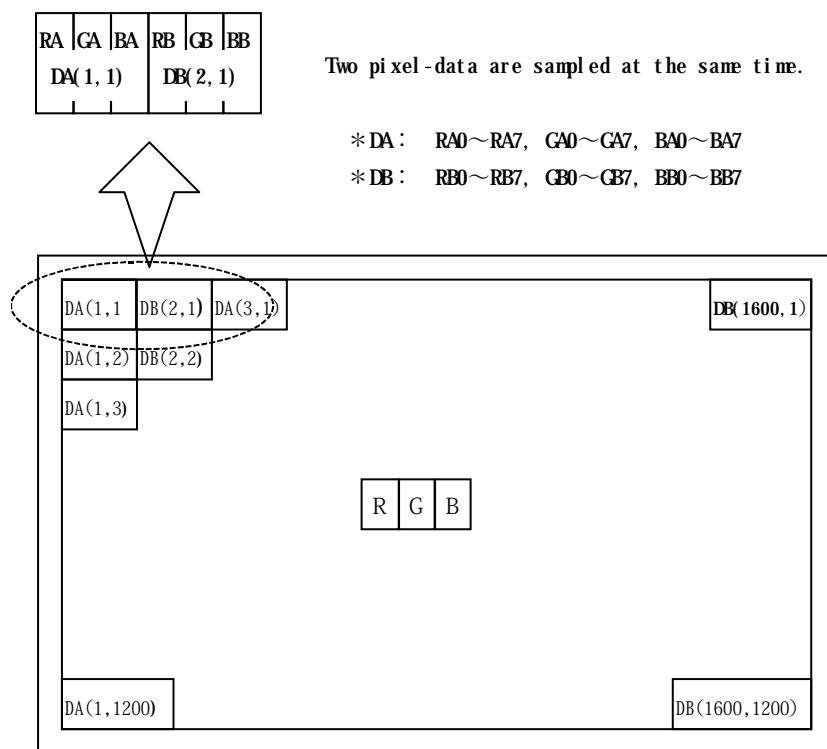

Display position of input data (H V)

8. Input Signals, Basic Display Colors and Gray Scale of Each Color

Colors & Gray scale	Gray Scale	Data signal																											
		RA0 RA1 RA2 RA3 RA4 RA5 RA6 RA7	GA GA GA GA GA GA GA GA	BA0 BA1 BA2 BA3 BA4 BA5 BA6 BA7																									
		RB0 RB1 RB2 RB3 RB4 RB5 RB6 RB7	GB0 GB1 GB2 GB3 GB4 GB5 GB6 GB7	BB0 BB1 BB2 BB3 BB4 BB5 BB6 BB7																									
Basic Color	Black	0	0	0	0	0	0	0	0	0	0	0	0	0	0	0	0	0	0	0	0	0	0	0	0	0	0	0	0
	Blue	0	0	0	0	0	0	0	0	0	0	0	0	0	0	0	0	1	1	1	1	1	1	1	1	1	1	1	1
	Green	0	0	0	0	0	0	0	0	1	1	1	1	1	1	1	1	0	0	0	0	0	0	0	0	0	0	0	0
	Cyan	0	0	0	0	0	0	0	0	1	1	1	1	1	1	1	1	1	1	1	1	1	1	1	1	1	1	1	1
	Red	1	1	1	1	1	1	1	1	0	0	0	0	0	0	0	0	0	0	0	0	0	0	0	0	0	0	0	0
	Magenta	1	1	1	1	1	1	1	1	0	0	0	0	0	0	0	0	1	1	1	1	1	1	1	1	1	1	1	1
	Yellow	1	1	1	1	1	1	1	1	1	1	1	1	1	1	1	1	0	0	0	0	0	0	0	0	0	0	0	0
	White	1	1	1	1	1	1	1	1	1	1	1	1	1	1	1	1	1	1	1	1	1	1	1	1	1	1	1	1
Gray Scale of Red	Black	GS0	0	0	0	0	0	0	0	0	0	0	0	0	0	0	0	0	0	0	0	0	0	0	0	0	0	0	0
	↑	GS1	1	0	0	0	0	0	0	0	0	0	0	0	0	0	0	0	0	0	0	0	0	0	0	0	0	0	0
	Darker	GS2	0	1	0	0	0	0	0	0	0	0	0	0	0	0	0	0	0	0	0	0	0	0	0	0	0	0	0
	↑	↓					↓							↓											↓				
	↓	↓					↓							↓											↓				
	Brighter	GS253	1	0	1	1	1	1	1	0	0	0	0	0	0	0	0	0	0	0	0	0	0	0	0	0	0	0	0
	↓	GS254	0	1	1	1	1	1	1	0	0	0	0	0	0	0	0	0	0	0	0	0	0	0	0	0	0	0	0
	Red	GS255	1	1	1	1	1	1	1	0	0	0	0	0	0	0	0	0	0	0	0	0	0	0	0	0	0	0	0
Gray Scale of Green	Black	GS0	0	0	0	0	0	0	0	0	0	0	0	0	0	0	0	0	0	0	0	0	0	0	0	0	0	0	0
	↑	GS1	0	0	0	0	0	0	0	1	0	0	0	0	0	0	0	0	0	0	0	0	0	0	0	0	0	0	0
	Darker	GS2	0	0	0	0	0	0	0	0	1	0	0	0	0	0	0	0	0	0	0	0	0	0	0	0	0	0	0
	↑	↓					↓							↓											↓				
	↓	↓					↓							↓											↓				
	Brighter	GS253	0	0	0	0	0	0	0	1	0	1	1	1	1	1	1	0	0	0	0	0	0	0	0	0	0	0	0
	↓	GS254	0	0	0	0	0	0	0	0	1	1	1	1	1	1	1	0	0	0	0	0	0	0	0	0	0	0	0
	Green	GS255	0	0	0	0	0	0	0	1	1	1	1	1	1	1	1	0	0	0	0	0	0	0	0	0	0	0	0
Gray Scale of Blue	Black	GS0	0	0	0	0	0	0	0	0	0	0	0	0	0	0	0	0	0	0	0	0	0	0	0	0	0	0	0
	↑	GS1	0	0	0	0	0	0	0	0	0	0	0	0	0	0	0	1	0	0	0	0	0	0	0	0	0	0	0
	Darker	GS2	0	0	0	0	0	0	0	0	0	0	0	0	0	0	0	0	1	0	0	0	0	0	0	0	0	0	0
	↑	↓					↓							↓											↓				
	↓	↓					↓							↓											↓				
	Brighter	GS253	0	0	0	0	0	0	0	0	0	0	0	0	0	0	0	1	0	1	1	1	1	1	1	1	1	1	1
	↓	GS254	0	0	0	0	0	0	0	0	0	0	0	0	0	0	0	0	1	1	1	1	1	1	1	1	1	1	1
	Blue	GS255	0	0	0	0	0	0	0	0	0	0	0	0	0	0	0	1	1	1	1	1	1	1	1	1	1	1	1

0 : Low level voltage, 1 : High level voltage.

Each basic color can be displayed in 256 gray scales from 8 bit data signals. According to the combination of total 48 bit data signals, the 16-million-color display can be achieved on the screen.

## 9. Optical Characteristics

Ta=25°C, Vcc =+12V

Parameter		Symbol	Condition	Min.	Typ.	Max.	Unit	Remark
Viewing Angle range	Vertical	$\theta 11$	$CR \geq 10$	80	88	—	Deg.	【Note1,4】
		$\theta 12$		80	88	—	Deg.	
	Horizontal	$\theta 21, \theta 22$		80	88	—	Deg.	
Contrast ratio		C R	$\theta = 0^\circ$	350	500	—		【Note2,4】
Response Time	Rise +Decay	$\tau r + \tau d$		—	20	55	ms	【Note3,4】
Chromaticity of white		Wx		0.283	0.313	0.343	—	【Note4】
		Wy		0.299	0.329	0.359	—	
Chromaticity of red		Rx		0.614	0.644	0.674	—	
		Ry		0.307	0.337	0.367	—	
Chromaticity of green		Gx		0.264	0.294	0.324	—	
		Gy		0.574	0.604	0.634	—	
Chromaticity of blue		Bx		0.114	0.144	0.174	—	
		By		0.063	0.093	0.123	—	
Luminance of white		YL		200	250	—	cd/m <sup>2</sup>	IL=6.0mA rms FL=60kHz 【Note4】
White Uniformity		$\delta w$		—	—	1.25	—	【Note5】

※The measurement shall be executed 30 minutes after lighting at rating.

The optical characteristics shall be measured in a dark room or equivalent state with the method shown in Fig.2 below.

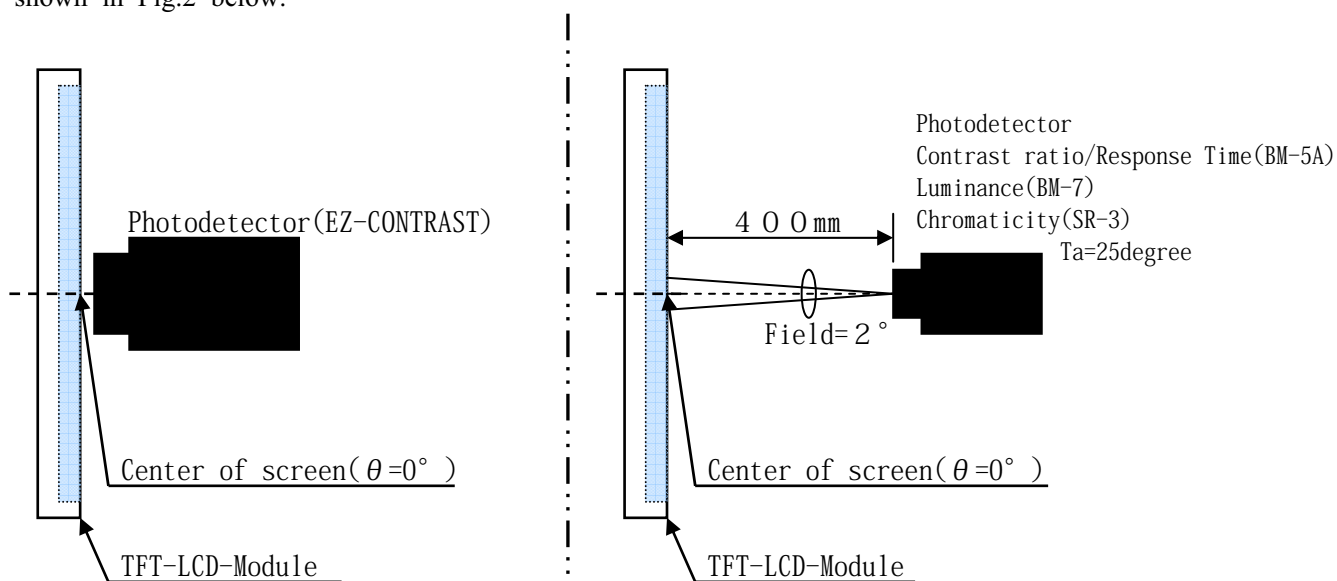
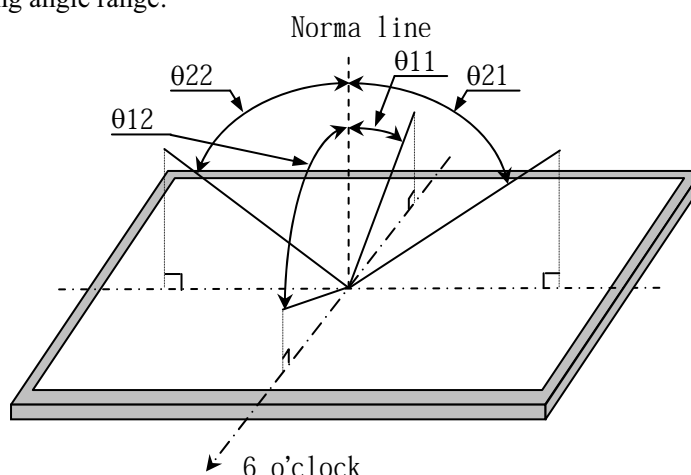

Fig2-1 Viewing angle measurement method

Fig2-2 Luminance/Contrast ratio/Response time/Chromaticity measurement method

Fig2 Optical characteristics measurement method

【Note1】 Definitions of viewing angle range:



【Note2】 Definition of contrast ratio:

The contrast ratio is defined as the following.

$$\text{Contrast Ratio (CR)} = \frac{\text{Luminance (brightness) with all pixels white}}{\text{Luminance (brightness) with all pixels black}}$$

【Note3】 Definition of response time:

The response time is defined as the following figure and shall be measured by switching the input signal for "black" and "white".

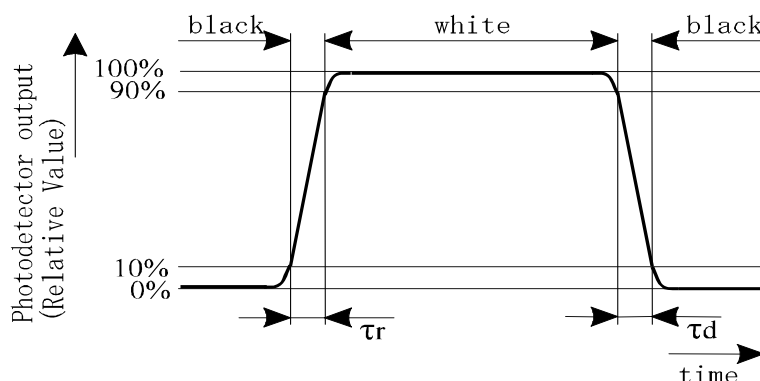

【Note4】 This shall be measured at center of the screen.

【Note5】 Definition of white uniformity:

White uniformity is defined as the following with nine measurements.

(A~I).

$$\delta W = \frac{\text{Maximum Luminance of nine points (brightness)}}{\text{Minimum Luminance of nine points (brightness)}}$$

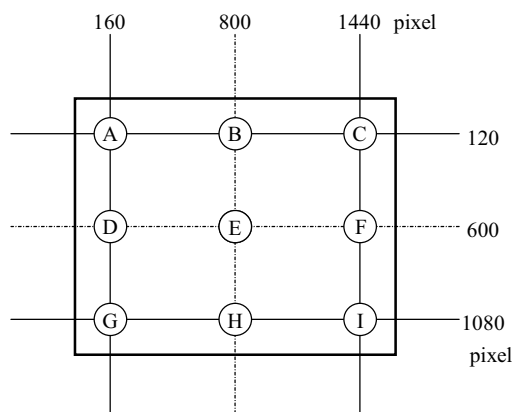



## 10. Display Quality

The display quality of the color TFT-LCD module shall be in compliance with the Incoming Inspection Standard.

## 11. Handling Precautions

- a) Be sure to turn off the power supply when inserting or disconnecting the cable.
- b) Be sure to design the cabinet so that the module can be installed without any extra stress such as warp or twist.
- c) Since the front polarizer is easily damaged, pay attention not to scratch it.
- d) Wipe off water drop immediately. Long contact with water may cause discoloration or spots.
- e) When the panel surface is soiled, wipe it with absorbent cotton or other soft cloth.
- f) Since the panel is made of glass, it may break or crack if dropped or bumped on hard surface. Handle with care.
- g) Since CMOS LSI is used in this module, take care of static electricity and injure the human earth when handling. Observe all other precautionary requirements in handling components.
- h) Since there is a circuit board in the module back, stress is not added at the time of a design assembly. Please make it like. If stress is added, there is a possibility that circuit parts may be damaged.
- i) Protection film is attached to the module surface to prevent it from being scratched .  
Peel the film off slowly , just before the use, with strict attention to electrostatic charges.  
Blow off 'dust' on the polarizer by using an ionized nitrogen.
- j) The polarizer surface on the panel is treated with Anti-Glare for low reflection. In case of attaching protective board over the LCD, be careful about the optical interface fringe etc. which degrades display quality.
- k) Do not expose the LCD panel to direct sunlight. Lightproof shade etc. should be attached when LCD panel is used under such environment.
- l) Make sure the mounting holes of the module are grounded sufficiently. Take electro-magnetic interference (EMI) into consideration.
- m) There are high voltage portions on the backlight and very dangerous. Careless touch may lead to electrical shock. When exchange lamps or service, turn off the power without fail.
- n) When handling LCD modules and assembling them into cabinets, please be noted that long-term storage in the environment of oxidization or deoxidization gas and the use of such materials as reagent, solvent, adhesive, resin, etc. which generate these gasses, may cause corrosion and discoloration of the LCD modules.
- o) Cold cathode fluorescent lamp in LCD panel contains a small amount of mercury, please follow local ordinances or regulations for disposal.
- p) Be careful of a back light lead not to pull by force at the time of the wiring to an inverter, or line processing.
- q) Liquid crystal contained in the panel may leak if the LCD is broken. Rinse it as soon as possible if it gets inside your eye or mouth by mistake.
- r) Notice: Never dismantle the module , because it will cause failure.
- s) Be careful when using it for long time with fixed pattern display as it may cause afterimage.  
(Please use a screen saver etc., in order to avoid an afterimage.)
- t) Adjusting volume have been set optimally before shipment, so do not change any adjusted value.  
If adjusted value is changed, the specification may not be satisfied.
- u) If a minute particle enters in the module and adheres to an optical material, it may cause display non-uniformity issue, etc. Therefore, fine-pitch filters have to be installed to cooling and inhalation hole if you intend to install a fan.
- v) The lamp used for this product is very sensitive to the temperature.  
Luminance decreases rapidly when it is used for a long time or repeatedly under the environment of the low temperature or the module is being cooled. Please avoid the continuous or repeating use of it under such an environment. It may decrease up to 50% of the initial luminance in about one month under the low temperature environment. Please consult our company when it is used under the environment like the above mentioned.

**12. Packing form**

Packing form is shown: Page 19

- a) Piling number of cartons : maximum 8 cartons
- b) Packing quantity in one carton : 2 modules
- c) Carton size : 583mm(W) × 478mm(H)× 215mm(D)
- d) Total mass of one carton filled with full modules : 8.9kg

**13. Reliability test items**

No.	Test item	Conditions
1	High temperature storage test	Ta=60°C 240h
2	Low temperature storage test	Ta=-25°C 240h
3	High temperature & high humidity operation test	Ta=40°C ; 95%RH 240h (No condensation)
4	High temperature operation test	Ta=50°C 240h (The panel temp. must be less than 60°C)
5	Low temperature operation test	Ta=0°C 240H
6	Vibration test (non- operating)	Waveform : Sine wave Frequency : 10 ~ 57Hz/Vibration width (one side) : 0.075mm : 58 ~ 500Hz/Gravity : 9.8m/s <sup>2</sup> Sweep time : 11minutes Test period : 3 hours (1 hour for each direction of X,Y,Z)
7	Shock test (non- operating)	Max. gravity : 490m/s <sup>2</sup> Pulse width : 11ms, sine wave Direction : ± X, ± Y, ± Z, once for each direction.
8	Thermal shock test	Ta=-20°C ~ 60°C ; 5 cycles Test period : 10 hours (1 hour for each temperature)
9	Altitude	Ta=50°C, 70kPa, 3,048m (10,000ft), t=24h (Operating) Ta=70°C, 12kPa, 15,240m (50,000ft), t=24h (Storage)

**【Result Evaluation Criteria】**

Under the display quality test conditions with normal operation state, these shall be no change which may affect practical display function. (normal operation state : Temperature:15~35°C, Humidity:45~75%, Atmospheric pressure:86~106kpa)

## 14. Others

### 1) Lot No. and indication Bar Code Label:

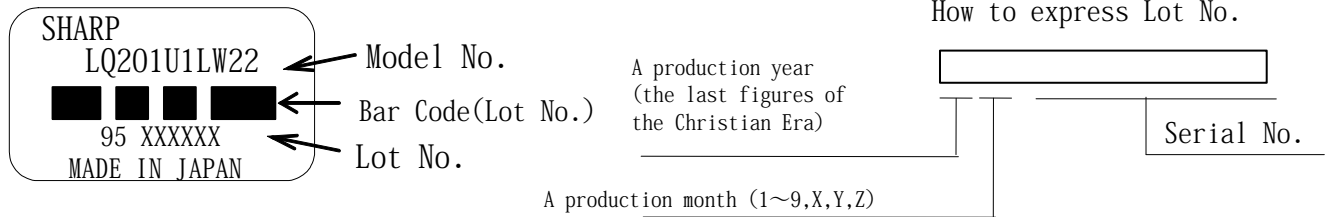

### 2) Packing Label

- ① Model No. (LQ201U1LW22)    ② Lot No. (Date)    ③ Quantity

社内品番: (4 S) LQ201U1LW22	
Bar Code (①)	
Lot NO.	: (1 T) 2009. XX. XX
Bar Code (②)	
Quantity: (Q)	2 pcs
Bar Code (③)	
ユーザ品番	:
シャープ物流用ラベルです。	

### 3) Adjusting volume have been set optimally before shipment, so do not change any adjusted value.

If adjusted value is changed, the specification may not be satisfied.

- 4) Disassembling the module can cause permanent damage and should be strictly avoided.
- 5) Please be careful since image retention may occur when a fixed pattern is displayed for a long time.
- 6) The chemical compound that causes the destruction of ozone layer is not being used.
- 7) Warning of mercury and material information of LPG(Light Pipe Guide) are labeled on the back of the module.

<ul style="list-style-type: none"> <li>• COLD CATHODE FLUORESCENT LAMP IN LCD PANEL CONTAINS A SMALL AMOUNT OF MERCURY, PLEASE FOLLOW LOCAL ORDINANCES OR REGULATION FOR DISPOSAL</li> <li>• 当該液晶ディスプレイパネルは蛍光管が組み込まれていますので、地方自治体の条例、または、規則に従って廃棄ください。</li> </ul>
<p><b>MATERIAL INFORMATION</b>  <b>&gt;PLASTIC LIGHT GUIDE:PMMA&lt;</b></p>

### 8) When any question or issue occurs, it shall be solved by mutual discussion.

## 15. Storage conditions

<Environmental condition range of storage temperature and humidity>

Temperature 0 to 40 degrees Celsius

Relative humidity 95% and below

【Note】 Please refer below as a mean value of the environmental conditions.

Summer time temperature 20 to 35 degrees Celsius

humidity 85% and below

Winter time temperature 5 to 15 degrees Celsius

humidity 85% and below

Please maintain within 240 hours of accumulated length of storage time, with conditions of 40 degrees Celsius and room humidity of 95%.

Direct sun light

Please keep the product in a dark room or cover the product to protect from direct sun light.

Atmospheric condition

Please refrain from keeping the product with possible corrosive gas or volatile flux.

Prevention of dew

\* Please store the product carton either on a wooden pallet or a stand / rack to prevent dew.

Do not place directly on the floor. In addition, to obtain moderate ventilation in between the pallet's top and bottom surfaces, pile the cartons up in a single direction and in order.

\* Please place the product cartons away from the storage wall.

\* Please maintain the storage area with an appropriate ventilation. It is recommendable to furnish the storage area with equipments such as ventilation systems.

\* Please maintain the ambient temperature within the range of natural environmental fluctuation.

Storage period

Within above mentioned conditions, maximum storage period should be one year.

LD-21034-19

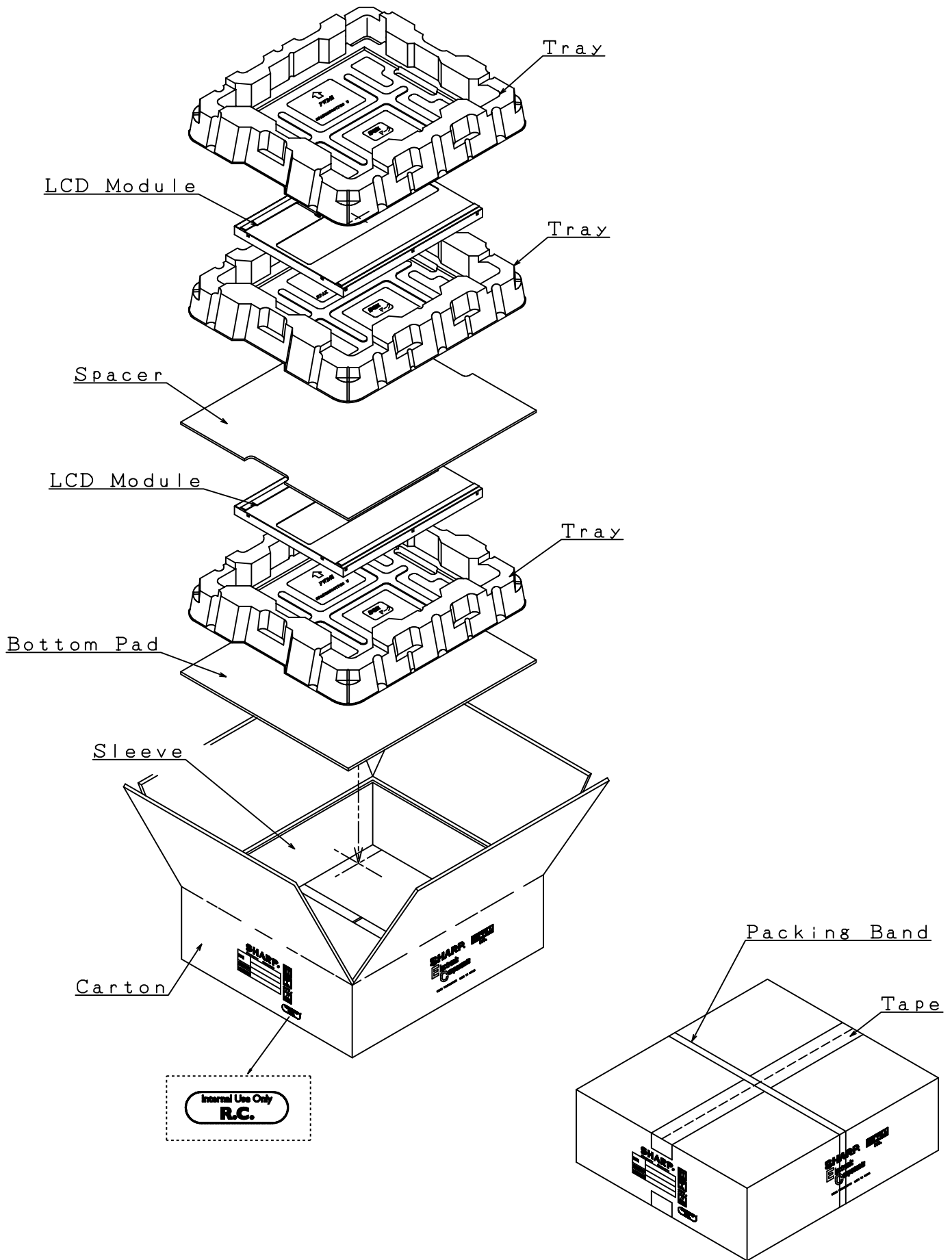

# Packing Form

1	High PINK
2	NC
3	NC
4	High BLUE
5	NC
6	NC
7	High ORANGE

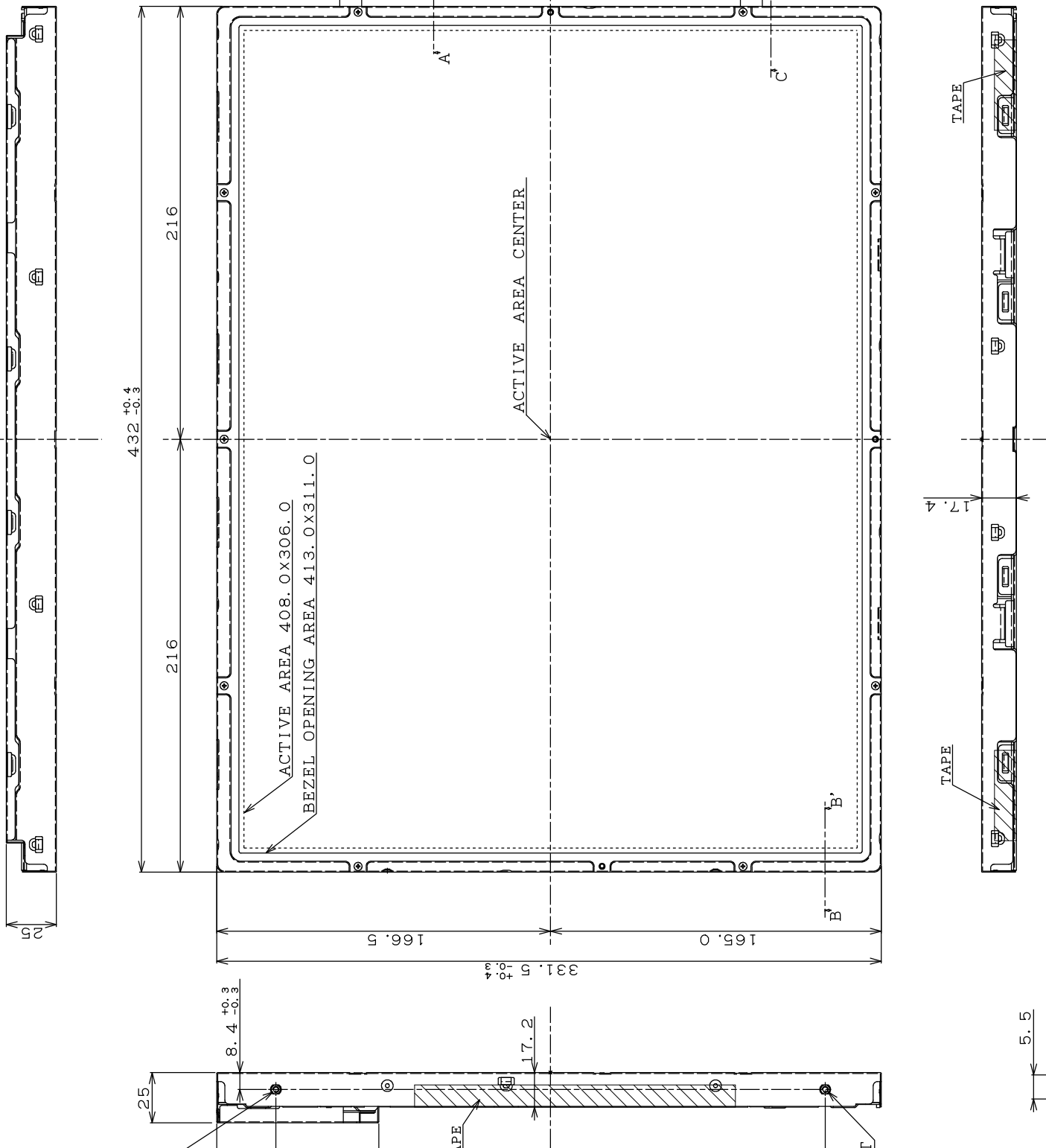

5.5

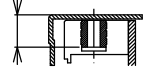

- 1) TOLERANCE
- 2) TOLERANCE
- 3) TOLERANCE
- 4) TOLERANCE
- 5) OBLIQUITY

