

SHARP

No.	LD-21956A
DATE	Oct. 6.2009

Revised

TECHNICAL LITERATURE
FOR
TFT - LCD module

RoHS Compliant

MODEL No. LQ215M1Lxxx

The technical literature is subject to change without notice.
So, please contact Sharp or its representative before designing
your product based on this literature.

PC DISPLAY & LCD MONITOR
BUSINESS PLANNING & MARKETING PROJECT TEAM,
DIVISION II,
MOBILE LIQUID CRYSTAL DISPLAY GROUP
SHARP CORPORATION

LD-21956A-1

These technical literature sheets are the proprietary product of SHARP CORPORATION("SHARP) and include materials protected under copyright of SHARP. Do not reproduce or cause any third party to reproduce them in any form or by any means, electronic or mechanical, for any purpose, in whole or in part, without the express written permission of SHARP.

In case of using the device for applications such as control and safety equipment for transportation(aircraft, trains, automobiles, etc.), rescue and security equipment and various safety related equipment which require higher reliability and safety, take into consideration that appropriate measures such as fail-safe functions and redundant system design should be taken.

Do not use the device for equipment that requires an extreme level of reliability, such as aerospace applications, telecommunication equipment(trunk lines), nuclear power control equipment and medical or other equipment for life support.

SHARP assumes no responsibility for any damage resulting from the use of the device, which does not comply with the instructions, and the precautions specified in these technical literature sheets.

Contact and consult with a SHARP sales representative for any questions about this device.

Table of contents

1.	Application.....	3
2.	Overview.....	3
3.	Mechanical Specifications	3
4.	Input Terminals.....	4
4-1.	TFT-LCD panel driving.....	4
4-2.	LED Backlight driving	5
5.	Absolute Maximum Ratings	6
6.	Electrical Characteristics.....	7
6-1.	TFT-LCD panel driving.....	7
7.	Timing Characteristics of Input Signals.....	10
7-1.	Timing characteristics.....	10
7-2.	Input data signals and display position on the screen.....	11
8.	Input Signals, Basic Display Colors and Gray Scale of Each Color.....	12
9.	Optical Characteristics	13
10.	Display Quality	15
11.	Handling Precautions	16
12.	Packing form.....	16
13.	RoHS Regulations.....	16
14.	Reliability Test Condition.....	17
Fig. 1	Outline Dimensions	19

1. Application

This technical literature applies to a color TFT-LCD module, LQ215M1L***.

2. Overview

This module is a color active matrix LCD module incorporating amorphous silicon TFT (Thin Film Transistor). It is composed of a color TFT-LCD panel, driver ICs, control circuit and power supply circuit and a backlight unit. Graphics and texts can be displayed on a 1920 x 3 x 1080 dots panel with 16,777,216 colors by using LVDS (Low Voltage Differential Signaling) to interface and supplying +5V DC supply voltage for TFT-LCD panel driving and supply voltage for backlight.

In this TFT-LCD panel, color filters of excellent color performance and LED backlights of high brightness are incorporated to realize brighter and clearer pictures, making this model optimum for use in multi-media applications.

Optimum viewing direction is 6 o'clock.

3. Mechanical Specifications

Parameter	Specifications	Unit
Display size	546.86 (21.53") Diagonal	mm
Active area	476.64 (H) x 268.11(V)	mm
Pixel format	1920(H) x 1080(V)	pixel
	(1 pixel = R+G+B dots)	
Aspect ratio	16 : 9	
Pixel pitch	0.24825(H) x 0.24825 (V)	mm
Pixel configuration	R,G,B vertical stripe	
Display mode	Normally white	
Surface treatment	Anti-glare, Haze=25%, hard-coating (3H)	

Parameter		Min.	Typ.	Max.	Unit
Unit outline dimensions [Note 1]	Width	495.1	495.6	496.1	mm
	Height	291.7	292.2	292.7	mm
	Depth	9.35	9.85	10.35	mm
Mass		-	-	TBD	g

[Note 1] Outline dimensions is shown in Fig.1

4. Input Terminals

4-1. TFT-LCD panel driving

CN1 (LVDS signals and +5.0V DC power supply)

Using connector : GS23302-0011R-7F (Foxconn) or equivalent.

Corresponding connector : FI-XB30SRL-HF11 (JAE) [Note 1]

Pin No.	Symbol	Function	Remark
Frame	GND	GND	[Note 3]
1	RxO0-	Receiver signal of LVDS (O0-)	[Note 2]
2	RxO0+	Receiver signal of LVDS (O0+)	[Note 2]
3	RxO1-	Receiver signal of LVDS (O1-)	[Note 2]
4	RxO1+	Receiver signal of LVDS (O1+)	[Note 2]
5	RxO2-	Receiver signal of LVDS (O2-)	[Note 2]
6	RxO2+	Receiver signal of LVDS (O2+)	[Note 2]
7	GND	GND	
8	RxOC-	Receiver signal of LVDS CLK (OC-)	[Note 2]
9	RxOC+	Receiver signal of LVDS CLK (OC+)	[Note 2]
10	RxO3-	Receiver signal of LVDS (O3-)	[Note 2]
11	RxO3+	Receiver signal of LVDS (O3+)	[Note 2]
12	RxE0-	Receiver signal of LVDS (E0-)	[Note 2]
13	RxE0+	Receiver signal of LVDS (E0+)	[Note 2]
14	GND	GND	
15	RxE1-	Receiver signal of LVDS (E1-)	[Note 2]
16	RxE1+	Receiver signal of LVDS (E1+)	[Note 2]
17	GND	GND	
18	RxE2-	Receiver signal of LVDS (E2-)	[Note 2]
19	RxE2+	Receiver signal of LVDS (E2+)	[Note 2]
20	RxEC-	Receiver signal of LVDS CLK (EC-)	[Note 2]
21	RxEC+	Receiver signal of LVDS CLK (EC+)	[Note 2]
22	RxE3-	Receiver signal of LVDS (E3-)	[Note 2]
23	RxE3+	Receiver signal of LVDS (E3+)	[Note 2]
24	GND	GND	
25	N.C.	No Connection, this pin should be open.	[Note 4]
26	N.C.	No Connection, this pin should be open.	[Note 4]
27	N.C.	No Connection, this pin should be open.	[Note 4]
28	Vcc	+5V power supply	
29	Vcc	+5V power supply	
30	Vcc	+5V power supply	
Frame	GND	GND	[Note 3]

[Note 1] Sharp is not responsible to its product quality, if the user applies a connector not corresponding to the above model.

[Note 2] Relation between RxIN_i(i=0,1,2) and actual data is shown in following section (4-3).

[Note 3] The shielding case is connected with signal GND.

[Note 4] Please use NC by OPEN. NC terminal is not connected with the internal circuit.

4-2. LED Backlight driving

Upper/Lower FPC Connector Pin Assignment

Using connector : 7080-Q10N-00R (Entry INDUSTRIAL CO.,LTD)

Corresponding FFC specification:

Temperature = 80°C, Voltage = 60V, Pin No. = 10, 0.5Pitch, PET, HF

Pin No	Symbol	Description
1	IRLED1	IRLED1 LED current sense for string 1
2	IRLED1	IRLED1 LED current sense for string 1
3	IRLED2	IRLED1 LED current sense for string 2
4	VLED	LED power supply
5	VLED	LED power supply
6	VLED	LED power supply
7	VLED	LED power supply
8	IRLED2	IRLED1 LED current sense for string 2
9	IRLED3	IRLED1 LED current sense for string 3
10	IRLED3	IRLED1 LED current sense for string 3

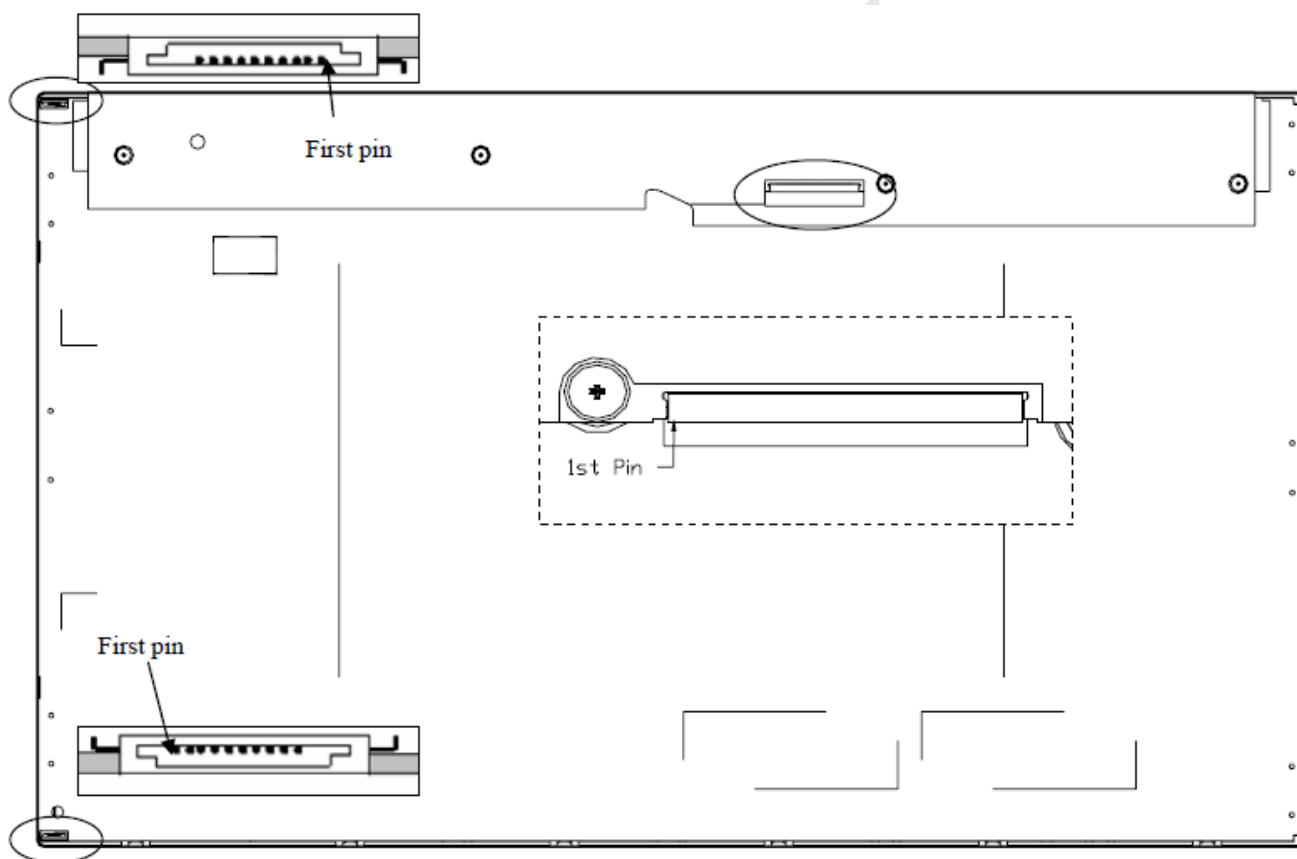

Rear View of LCM

5. Absolute Maximum Ratings

Parameter	Symbol	Condition	Ratings		Unit	Remark
			Min.	Max.		
Input voltage	V_I	$T_a=25^\circ\text{C}$	-0.3	+4.3	V	[Note 1]
+5V supply voltage	V_{CC}	$T_a=25^\circ\text{C}$	-0.3	+6.0	V	
LED Driver supply voltage	LED_V_{CC}	$T_a=25^\circ\text{C}$	(TBD)	(TBD)	V	
LED Current	I_{LED}	$T_a=25^\circ\text{C}$	(TBD)	(TBD)	A	
Storage temperature	T_{stg}	—	-20	+60	$^\circ\text{C}$	[Note 3]
Operating temperature (Ambient)	T_{opa}	—	0	+50	$^\circ\text{C}$	

[Note 1] LVDS signals

[Note 2] The relative humidity must not exceed 90% non-condensing at temperatures of 40°C or less.

At temperatures greater than 40°C , the wet bulb temperature must not exceed 39°C .

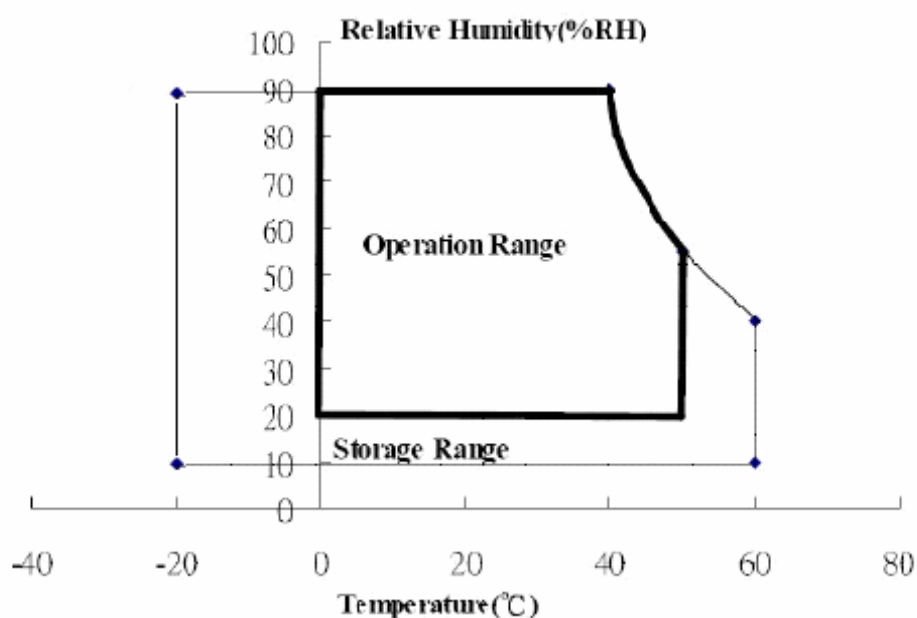

6. Electrical Characteristics

6-1.TFT-LCD panel driving

Ta=+25°C

Parameter	Symbol	Min.	Typ.	Max.	Unit	Remark	
Supply voltage	V _{CC}	+4.5	+5.0	+5.5	V	[Note 2]	
Permissible input ripple voltage	V _{RP}	-	-	150	mV _{P-P}	V _{CC} = +5.5V	
Current dissipation	I _{CC}	-	(TBD)	(TBD)	mA	[Note 3]	
Rush Current	I _{rush}	-	1.6	3.0	A	[Note 4]	
Input voltage range	V _I	(TBD)		(TBD)	V	LVDS signals	
Differential input threshold voltage	High	V _{TH}	-	-	+100	mV	V _{CM} = +1.2V [Note 1]
	Low	V _{TL}	-100	-	-	mV	
Input current (High)	I _{OH}	-	-	(TBD)	μA	V _I = +2.4V V _{CC} = +3.6V	
Input current (Low)	I _{OL}	-	-	(TBD)	μA	V _I = 0V V _{CC} = 3.6V	
Terminal resistor	R _T	-	(TBD)	-	Ω	Differential input	

[Note 1] V_{CM} : Common mode voltage of LVDS driver.

[Note 2] On-off conditions for supply voltage

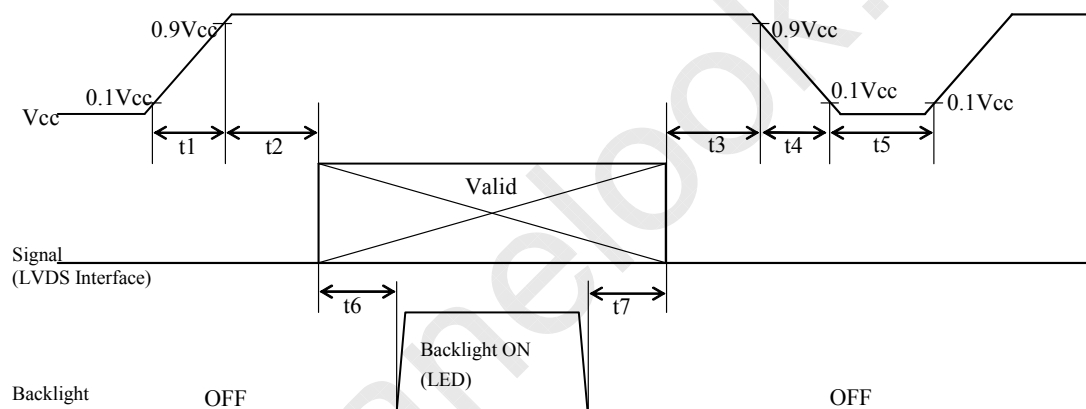

Symbol	Min.	Typ.	Max.	Unit	Remark
t1	0.1	-	10	ms	
t2	0	30	50	ms	
t3	0	20	50	ms	
t4	0.1	-	10	ms	
t5	1000	-	-	ms	
t6	200	250	-	ms	*1
t7	100	250	-	ms	*1

*1 : As for the power sequence for backlight, it is recommended to apply above mentioned input timing. If the backlight is lit on and off at a timing other than shown above, displaying image may get disturbed. This is due to variation of output signal from timing generator when LVDS signal is changed from on to off or vice versa, but has no harm to the module itself.

(Note 2-1) Do not keep the interface signal high-impedance or unusual signal when power is on.

(Note 2-2)V_{CC}-dip conditions

[Note 3] Typical current situation : 16-gray-bar pattern.

$V_{CC}=+5.0V$

Maximum current situation : $V_{CC}=+5.0V$

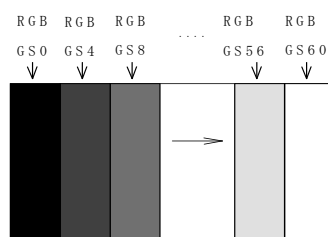

[Note 4] Test condition :

(1) $V_{DD} = 5 V$, V_{DD} rising time = $470 \mu s \pm 10\%$

(2) Pattern: Mosaic pattern

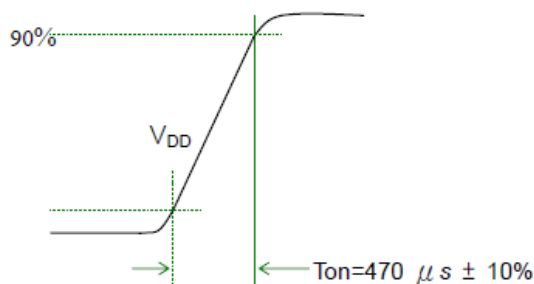

(3) Test circuit

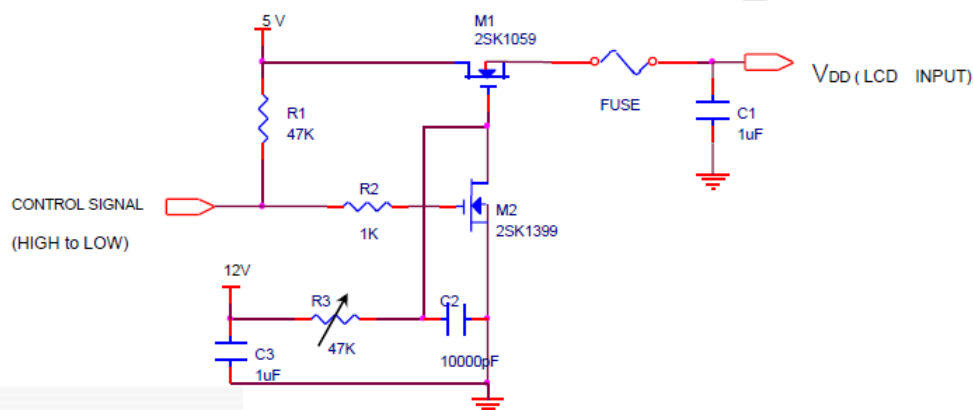

[Note 5] LVDS signal definition

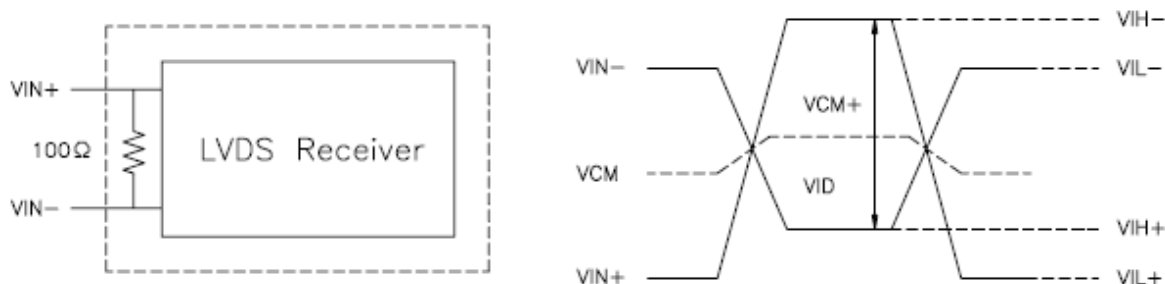

V_{IN+} = Positive differential DATA & CLK Input

V_{IN-} = Negative differential DATA & CLK Input

$V_{ID} = V_{IN+} - V_{IN-}$,

$\Delta V_{CM} = |V_{CM+} - V_{CM-}|$,

$\Delta V_{ID} = |V_{ID+} - V_{ID-}|$,

$V_{ID+} = |V_{IH+} - V_{IH-}|$,

$V_{ID-} = |V_{IL+} - V_{IL-}|$,

$V_{CM} = (V_{IN+} + V_{IN-})/2$,

$V_{CM+} = (V_{IH+} + V_{IH-})/2$,

$V_{CM-} = (V_{IL+} + V_{IL-})/2$,

6-2. Backlight driving

(Ta=+25°C)

Parameter	Symbol	Min.	Typ.	Max.	Unit	Remark
Supply voltage range	VLED	-	+42.9	+45.5	V	(Duty 100%)
Current dissipation	ILED	—	-	360	mA	[Note 1,2,3]
Power Consumption	PLED			16.38	W	[Note 4]
Permissive input ripple voltage	-	—	-	(TBD)	mV _{P-P}	[Note 1]
LED life time	LBL	-	30,000	-	Hour	[Note 5]

[Note 1] There are one Light Bar, and the specified current is input LED chip 100% duty current.

[Note 2] The sensing current of each string is 60mA.

[Note 3] Each light bar have three current sensing strings, so that each light bar input current is 180mA.

[Note 4] $PLED = ILED \times VLED$.

[Note 5] The life time is determined as the time at which luminance of the LED becomes 50% of the initial brightness or not normal lighting at ILED=360mA on condition of continuous operating at 25±2°C.

7. Timing Characteristics of Input Signals

7-1. Timing characteristics

$V_{CC}=+3.0V\sim+3.6V$, $T_a=0\text{ }^{\circ}\text{C}\sim+50\text{ }^{\circ}\text{C}$

	Parameter	Symbol	Min.	Typ.	Max.	Unit	Remark
Clock	Frequency	1/Tc	60	72	87.5	MHz	
	Period	Tc	11.43	13.89	16.7	ns	
Data Enable Signal	Horizontal period	TH	1000	1088	1120	clock	
	Horizontal period (High)	THd	960	960	960	clock	
	H-Blank (TH-THd)	THb	40	128	160	clock	
	Vertical period	TV	1090	1100	1160	Line	
	Vertical period (High)	TVd	1080	1080	1080	line	
	V-Blank (TV-TVd)	TVb	10	20	80	line	
	Frequency	fV	50	60	75	Hz	

[Note 1] Because this module is operated by DE only mode, Hsync and Vsync input signals should be set to low Logic level or ground. Otherwise, this module would operate abnormally.

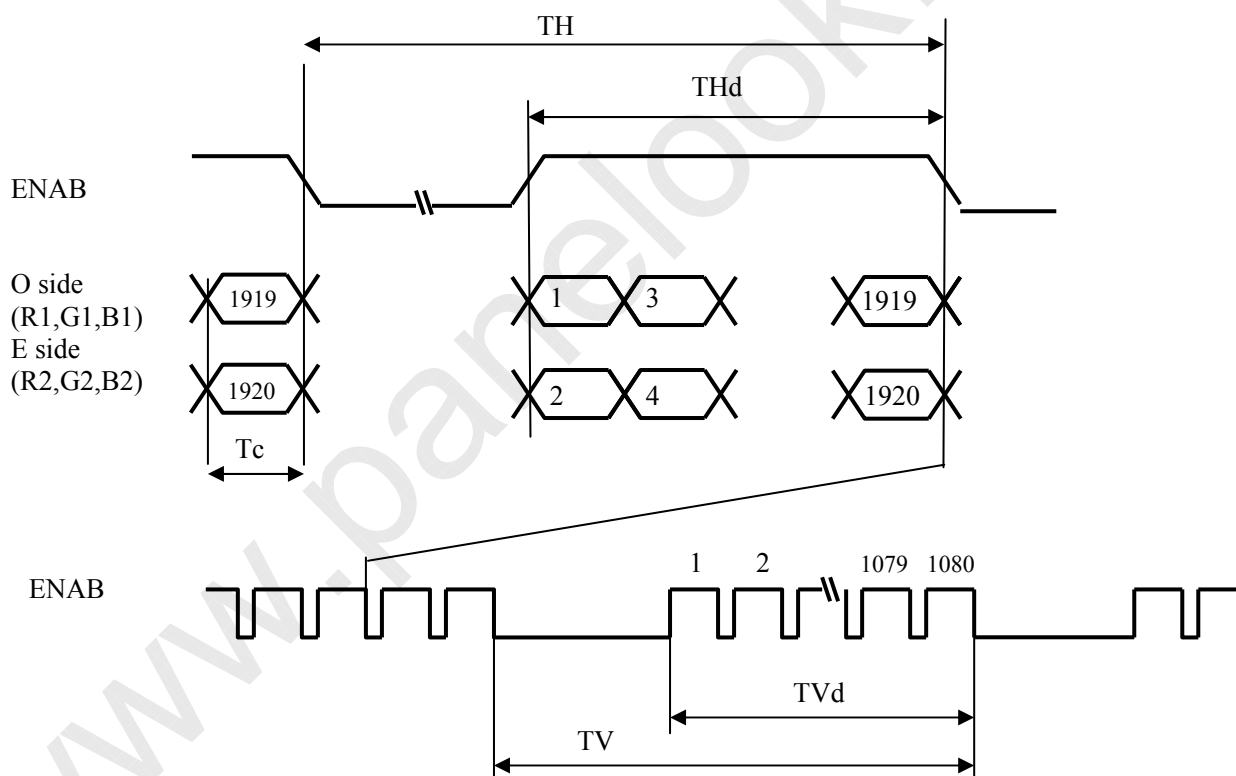

7-2. Input data signals and display position on the screen

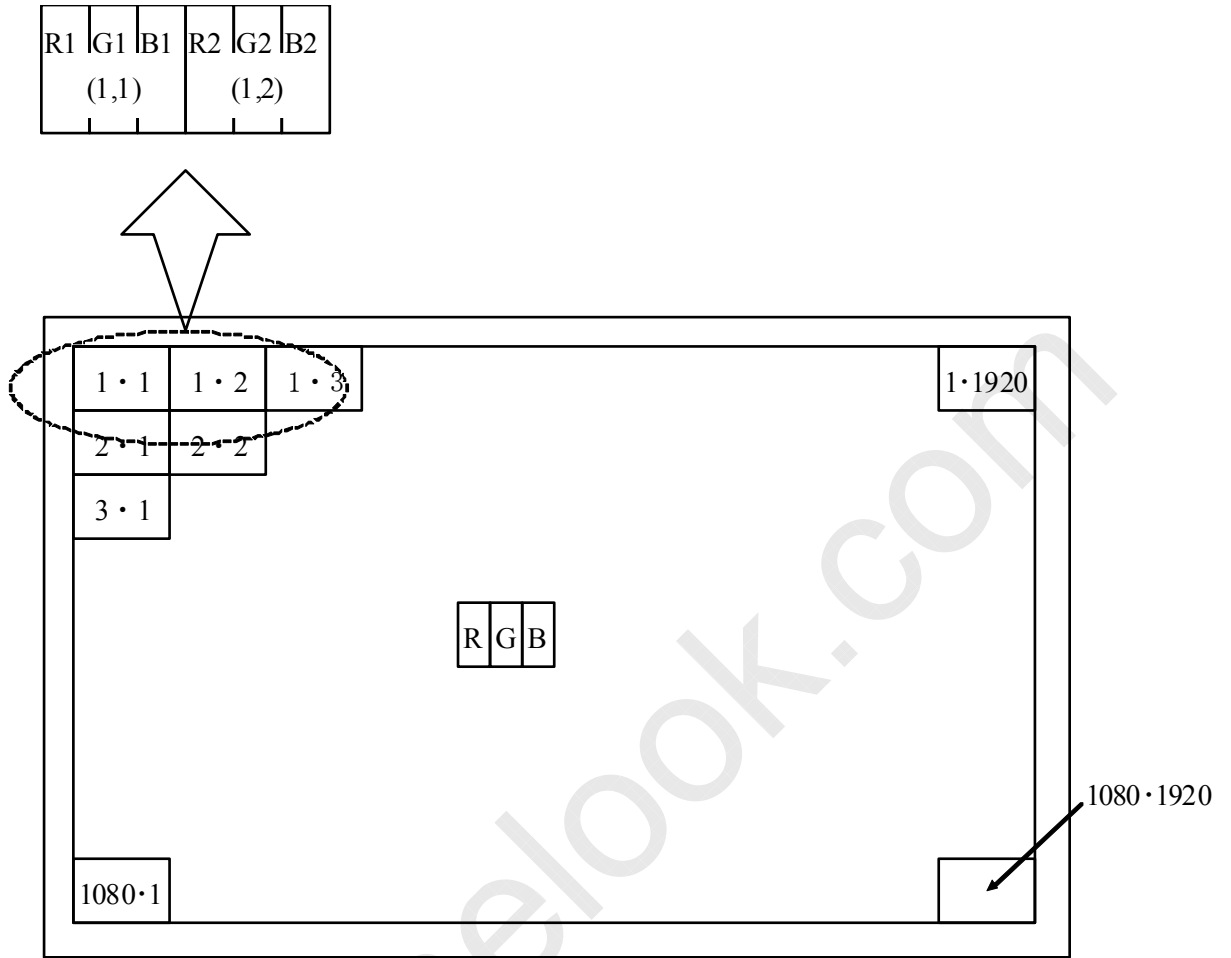

Display position of input data(V · H)

8. Input Signals, Basic Display Colors and Gray Scale of Each Color

	Colors & Gray scale	Data signal																								
		Gray Scale	R0	R1	R2	R3	R4	R5	R6	R7	G0	G1	G2	G3	G4	G5	G6	G7	B0	B1	B2	B3	B4	B5	B6	B7
Basic Color	Black	—	0	0	0	0	0	0	0	0	0	0	0	0	0	0	0	0	0	0	0	0	0	0	0	0
	Blue	—	0	0	0	0	0	0	0	0	0	0	0	0	0	0	0	0	1	1	1	1	1	1	1	1
	Green	—	0	0	0	0	0	0	0	0	1	1	1	1	1	1	1	1	0	0	0	0	0	0	0	0
	Cyan	—	0	0	0	0	0	0	0	0	1	1	1	1	1	1	1	1	1	1	1	1	1	1	1	1
	Red	—	1	1	1	1	1	1	1	1	0	0	0	0	0	0	0	0	0	0	0	0	0	0	0	0
	Magenta	—	1	1	1	1	1	1	1	1	0	0	0	0	0	0	0	0	1	1	1	1	1	1	1	1
	Yellow	—	1	1	1	1	1	1	1	1	1	1	1	1	1	1	1	1	0	0	0	0	0	0	0	0
	White	—	1	1	1	1	1	1	1	1	1	1	1	1	1	1	1	1	1	1	1	1	1	1	1	1
Gray Scale of Red	Black	0	0	0	0	0	0	0	0	0	0	0	0	0	0	0	0	0	0	0	0	0	0	0	0	
	↑	1	1	0	0	0	0	0	0	0	0	0	0	0	0	0	0	0	0	0	0	0	0	0	0	
	Darker	2	0	1	0	0	0	0	0	0	0	0	0	0	0	0	0	0	0	0	0	0	0	0	0	
	↑	↓				↓						↓						↓				↓				
	↓	↓				↓						↓						↓				↓				
	Brighter	253	1	0	1	1	1	1	1	0	0	0	0	0	0	0	0	0	0	0	0	0	0	0	0	
	↓	254	0	1	1	1	1	1	1	0	0	0	0	0	0	0	0	0	0	0	0	0	0	0	0	
	Red	255	1	1	1	1	1	1	1	0	0	0	0	0	0	0	0	0	0	0	0	0	0	0	0	
Gray Scale of Green	Black	0	0	0	0	0	0	0	0	0	0	0	0	0	0	0	0	0	0	0	0	0	0	0	0	
	↑	1	0	0	0	0	0	0	0	1	0	0	0	0	0	0	0	0	0	0	0	0	0	0	0	
	Darker	2	0	0	0	0	0	0	0	0	1	0	0	0	0	0	0	0	0	0	0	0	0	0	0	
	↑	↓				↓						↓						↓				↓				
	↓	↓				↓						↓						↓				↓				
	Brighter	253	0	0	0	0	0	0	0	1	0	1	1	1	1	1	1	0	0	0	0	0	0	0	0	
	↓	254	0	0	0	0	0	0	0	0	1	1	1	1	1	1	1	0	0	0	0	0	0	0	0	
	Green	255	0	0	0	0	0	0	0	1	1	1	1	1	1	1	1	0	0	0	0	0	0	0	0	
Gray Scale of Blue	Black	0	0	0	0	0	0	0	0	0	0	0	0	0	0	0	0	0	0	0	0	0	0	0	0	
	↑	1	0	0	0	0	0	0	0	0	0	0	0	0	0	0	0	1	0	0	0	0	0	0	0	
	Darker	2	0	0	0	0	0	0	0	0	0	0	0	0	0	0	0	0	1	0	0	0	0	0	0	
	↑	↓				↓						↓						↓				↓				
	↓	↓				↓						↓						↓				↓				
	Brighter	253	0	0	0	0	0	0	0	0	0	0	0	0	0	0	0	1	0	1	1	1	1	1	1	
	↓	254	0	0	0	0	0	0	0	0	0	0	0	0	0	0	0	0	1	1	1	1	1	1	1	
	Blue	255	0	0	0	0	0	0	0	0	0	0	0	0	0	0	0	1	1	1	1	1	1	1	1	

0 : Low level voltage, 1 : High level voltage

Each basic color can be displayed in 256 gray scales from 8 bit data signals. According to the combination of total 24 bit data signals, the 16,777,216-color display can be achieved on the screen.

9. Optical Characteristics

Ta=+25°C, Vcc=+3.3V

Parameter		Symbol	Condition	Min.	Typ.	Max.	Unit	Remark
Viewing angle range	Horizontal	θ21, θ22	CR ≥ 10	75	85	-	Deg.	[Note 1,2,3]
	Vertical	θ11, θ12		70	80	-	Deg.	
Contrast ratio		CRn	θ=0°	700	1000	-		[Note 1,3,5]
Response time		τr	θ=0°	-	1.5	3	ms	[Note 1,4,5]
		τd		-	3.5	7	ms	
		τr + τd		-	5	10	ms	
Chromaticity of white		x	θ=0°	0.283	0.313	0.343		[Note 1,5]
		y		0.299	0.329	0.359		
Luminance of white		YLI	θ=0°	(200)	250	-	cd/m ²	[Note 1,5]
White Uniformity		δW		0.70	0.75	-		[Note 1,6]
Cross Talk(In 60HZ)		Ct		-	-	2	%	[Note 7]

The measurement shall be executed 30 minutes after lighting at rating. Condition : (D_{PWM}=100%)

The optical characteristics shall be measured in a dark room or equivalent.

[Note 1] Optical Characteristics Measurements

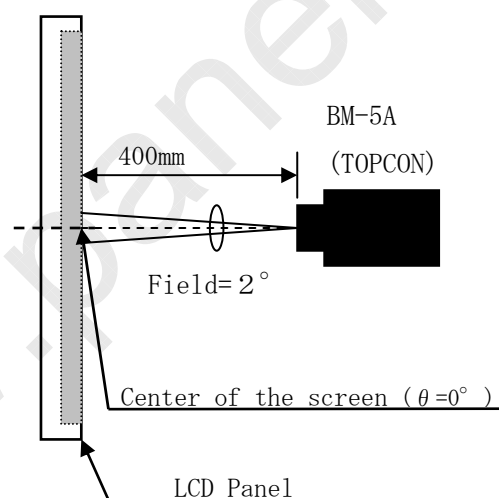

[Note 2] Definitions of viewing angle range:

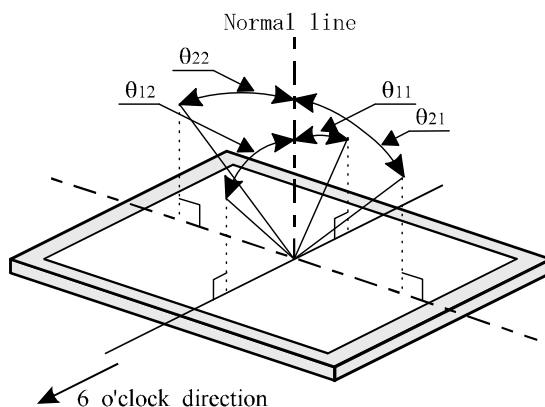

[Note 3] Definition of contrast ratio:

The contrast ratio is defined as the following.

$$\text{Contrast Ratio (CR)} = \frac{\text{Luminance (brightness) with all pixels white}}{\text{Luminance (brightness) with all pixels black}}$$

[Note 4] Definition of response time:

The response time is defined as the following figure and shall be measured by switching the input signal for "black" and "white" .

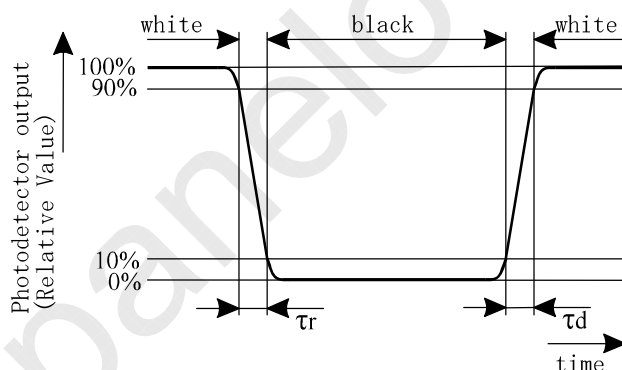

[Note 5] This shall be measured at center of the screen.

[Note 6] Definition of white uniformity:

White uniformity is defined as the following with nine measurements (P1 ~ P9).

Minimum Luminance of nine points (Brightness)

$$\delta_w = \frac{\text{Minimum Luminance of nine points (Brightness)}}{\text{Maximum Luminance of nine points (Brightness)}}$$

Maximum Luminance of nine points (Brightness)

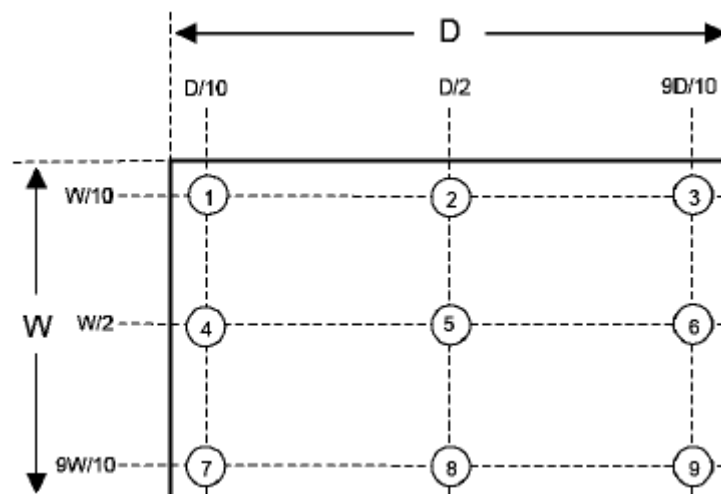

[Note 7] Definition of the cross talk

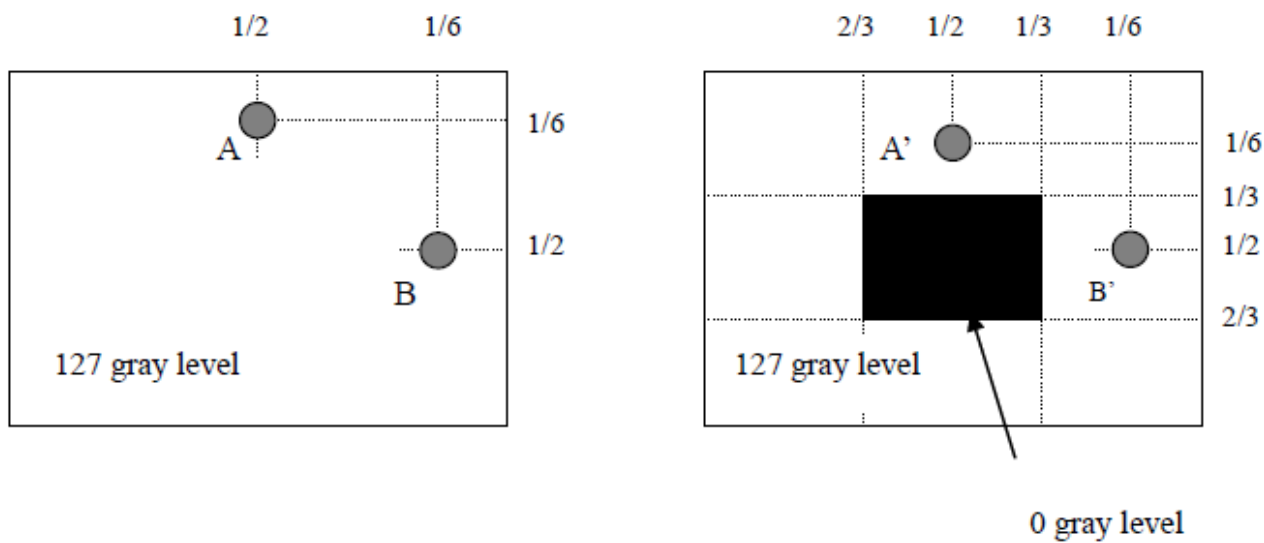

$1 \frac{LA-LA'}{LA} \times 100\% = 2\% \text{ max.}$, LA and LA' are brightness at location A and A'

$1 \frac{LB-LB'}{LB} \times 100\% = 2\% \text{ max.}$, LB and LB' are brightness at location B and B'

10. Display Quality

The display quality of the color TFT-LCD module shall be in compliance with the Incoming Inspection Standard.

11. Handling Precautions

- a) Be sure to turn off the power supply when inserting or disconnecting the cable.
- b) Be sure to design the cabinet so that the module can be installed without any extra stress such as warp or twist.
- c) Since the front polarizer is easily damaged, pay attention not to scratch it.

Blow away dust on the polarizer with antistatic N₂ blow. It is undesirable to wipe off because a polarizer is sensitive.

It is recommended to peel off softly using the adhesive tape when soil or finger oil is stuck to the polarizer.

When unavoidable, wipe off carefully with a cloth for wiping lenses.

- d) Wipe off water drop immediately. Long contact with water may cause discoloration or spots.
- e) When the panel surface is soiled, wipe it with absorbent cotton or other soft cloth.
- f) Since the panel is made of glass, it may break or crack if dropped or bumped on hard surface.

Handle with care.

- g) Since CMOS LSI is used in this module, take care of static electricity and injure the human earth when handling.

Observe all other precautionary requirements in handling components.

- h) Since there is a circuit board in the module back, stress is not added at the time of a design assembly.

Please make it like. If stress is added, there is a possibility that circuit parts may be damaged.

- i) Protection film is attached to the module surface to prevent it from being scratched .

Peel the film off slowly , just before the use, with strict attention to electrostatic charges.

Blow off 'dust' on the polarizer by using an ionized nitrogen.

- j) Do not expose the LCD module to a direct sunlight, for a long period of time to protect the module from the ultra violet ray.

- k) When handling LCD modules and assembling them into cabinets, please avoid that long-terms storage in the environment of oxidization or deoxidization gas and the use of such materials as reagent, solvent, adhesive, resin, etc. which generate these gasses, may cause corrosion and discoloration of the modules.

- l) Liquid crystal contained in the panel may leak if the LCD is broken. Rinse it as soon as possible if it gets inside your eye or mouth by mistake.

- m) Notice : Never dismantle the module , because it will cause failure.

Please don't remove the fixed tape, insulating tape etc that was pasted on the original module.

(Except for protection film of the panel and the crepe tape (yellow tape) of fixing lamp cable temporarily.)

- n) Be careful when using it for long time with fixed pattern display as it may cause afterimage. (Please use a screen saver etc., in order to avoid an afterimage.)

- o) Please handle carefully not to charge excessive stress onto the back of the module.Excessive stress may cause unrepairable damage to the module.

12. Packing form

TBD

13. RoHS Regulations

This LCD module is compliant with RoHS Directive.

14. Reliability Test Condition

Test Item	Test Condition	Judgment	Remark
High temperature storage	60°C, 240Hrs	Note 1	Note 2
Low temperature storage	-20°C, 240Hrs	Note 1	Note 2
High temperature & high humidity operation	40°C, 90%RH, 240Hrs (No condensation)	Note 1	Note 2
High temperature operation	50°C, 240Hrs	Note 1	Note 2
Low temperature operation	0°C, 240Hrs	Note 1	Note 2
Thermal Shock (non-operation)	-20°C~60°C -20°C /1Hr, 60°C /1Hr, 100cycles	Note 1	Note 2
Electrostatic discharge (ESD) (non-operation)	Contact: +/-8kV, 150pF(330ohms), 10 times/1 point, 1 time/1 sec, total 16 points Air discharge: +/-15kV, 150pF(330ohms), 10 times/1 point, 1 time/1 sec, total 9 points	Note 1	Note 2
Vibration (non-operation)	Vibration level : 1.5G Bandwidth : 10-300Hz Waveform : sine wave, sweep rate : 10min 30 min for each direction X, Y, Z (1.5 Hrs in total)	Note 1	Note 2
Mechanical Shock (non-operation)	Shock level : 50G, 11ms Waveform : Half sine wave Direction : ±X, ±Y, ±Z One time each direction	Note 1	Note 2
MTBF Demonstration	30,000 hours with confidence level 90%	Note 1	Note 3

Note1: Pass: Normal display image with no obvious non-uniformity and no line defect.
Partial transformation of the module parts should be ignored.

Fail: No display image, obvious non-uniformity, or line defects.

Note2: Evaluation should be tested after storage at room temperature for two hours.

Note 3: The MTBF calculation is based on the assumption that the failure rate distribution meets the Exponential Model (CCFL excluded).

Fig. 1 Outline Dimensions
Front side

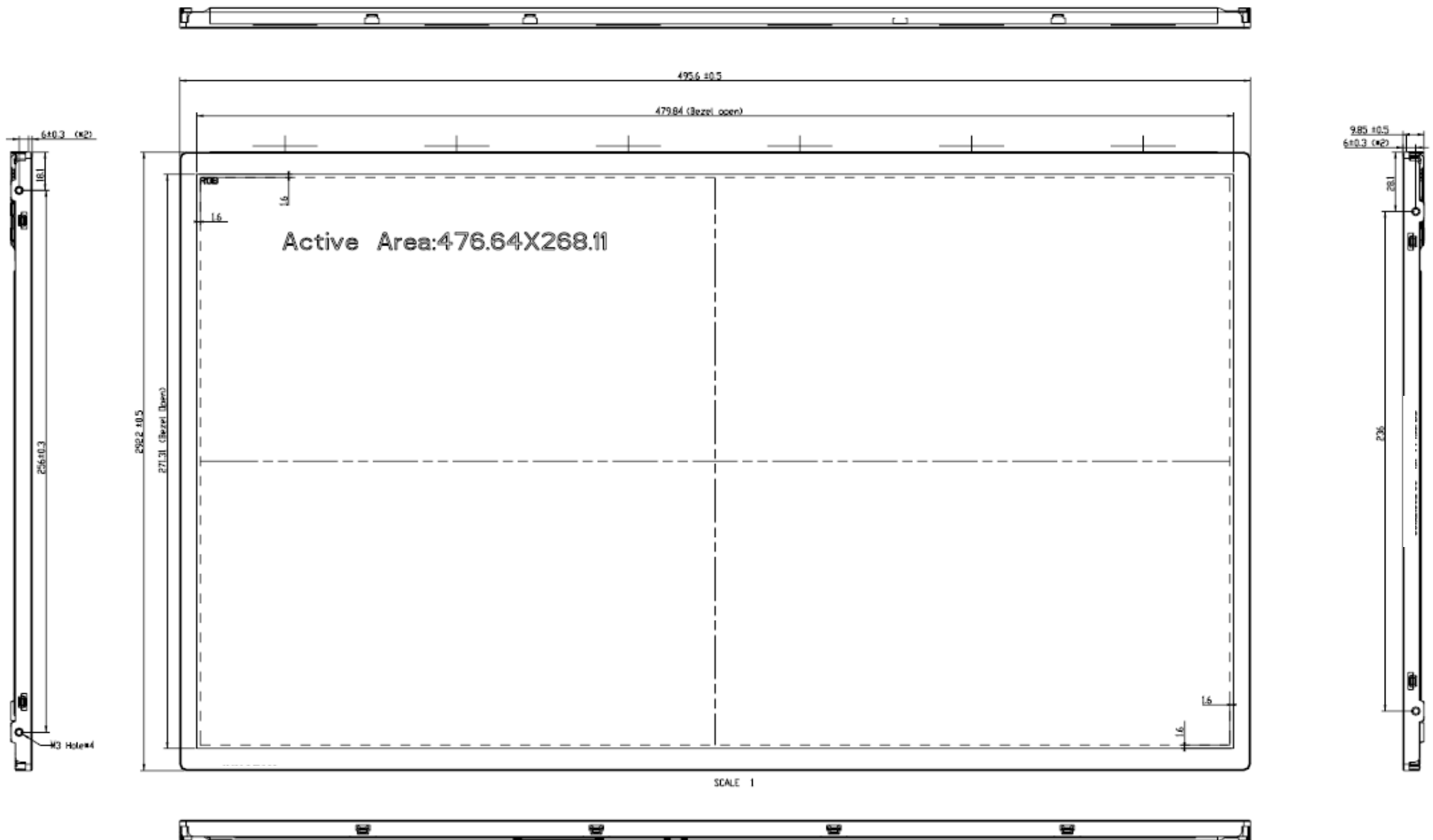

Rear side

