

PREPARED BY: _____	DATE _____	SHARP	SPEC No. LD-16404
APPROVED BY: _____	DATE _____		FILE No.
			ISSUE: Apr., 09, 2004
			PAGE : 21 pages
		LIQUID CRYSTAL DISPLAY GROUP SHARP CORPORATION SPECIFICATION	APPLICABLE GROUP AVC LIQUID CRYSTAL DISPLAY GROUP

DEVICE SPECIFICATION FOR

TFT - LCD module

MODEL No. LQ315T3LZ14

CUSTOMER'S APPROVAL

DATE _____

BY _____

PRESENTED

BY K. Shiono

K. SHIONO

Department General manager

Development Engineering Dept. 3

DEVELOPMENT CENTER

AVC LIQUID CRYSTAL DISPLAY GROUP

SHARP CORPORATION

1. Application

This specification applies to the color TFT-LCD module LQ315T3LZ14.

* These specification sheets are proprietary products of SHARP CORPORATION (“SHARP”) and include materials protected under copyright of SHARP. Do not reproduce or cause any third party to reproduce them in any form or by any means, electronic or mechanical, for any purpose, in whole or in part, without the express written permission of SHARP.

* The device listed in these specification sheets was designed and manufactured for use in AV equipment.

* In case of using the device for applications such as control and safety equipment for transportation (aircraft, trains, automobiles, etc.), rescue and security equipment and various safety related equipment which require higher reliability and safety, take into consideration that appropriate measures such as fail-safe functions and redundant system design should be taken.

* Do not use the device for equipment that requires an extreme level of reliability, such as aerospace applications, telecommunication equipment (trunk lines), nuclear power control equipment and medical or other equipment for life support.

* SHARP assumes no responsibility for any damage resulting from the use of the device which does not comply with the instructions and the precautions specified in these specification sheets.

* Contact and consult with a SHARP sales representative for any questions about this device.

2. Overview

This module is a color active matrix LCD module incorporating amorphous silicon TFT (Thin Film Transistor). It is composed of a color TFT-LCD panel, driver ICs, control circuit, power supply circuit, inverter circuit and back light system etc. Graphics and texts can be displayed on a 1366×RGB×768 dots panel with 16,777,216 colors by using LVDS (Low Voltage Differential Signaling) to interface, +5V of DC supply voltages and +12V of DC supply voltage for back light.

This module also includes the DC/AC inverter to drive the CCFT .

And in order to improve the response time of LCD, this module applies the O/S (over shoot) driving technology for the control circuit .In the O/S driving technology, signals are being applied to the Liquid Crystal according to a pre-fixed process as an image signal of the present frame when a difference is found between image signal of the previous frame and that of the current frame after comparing them.

By using the captioned process, the image signals of this LCD module are being set so that image response can be completed within one frame, as a result, image blur can be improved and clear image performance can be realized.

3. Mechanical Specifications

Parameter	Specifications	Unit
Display size	80.01 (Diagonal)	cm
	31.5 (Diagonal)	inch
Active area	697.44 (H) x 392.12 (V)	mm
Pixel Format	1366 (H) x 768 (V) (1pixel = R + G + B dot)	pixel
Pixel pitch	0.51057(H) x 0.51057 (V)	mm
Pixel configuration	R, G, B vertical stripe	
Display mode	Normally black	
Unit Outline Dimensions *1	780.0(W) x 450.0(H) x 51.0(D)	mm
Mass	9.2 +/- 0.3	kg
Surface treatment	Anti glare, low reflection coating Hard coating: 2H Haze: 23 +/- 5%	

(*1)Outline dimensions are shown in Fig.1

4. Input Terminals

4-1. TFT panel driving

CN1 (Interface signals and +5V DC power supply) (Shown in Fig.1)

Using connector : FI-X30SSL-HF (Japan Aviation Electronics Ind. , Ltd.)

Mating connector : FI-X30H,FI-X30C or FI-X30M (Japan Aviation Electronics Ind. , Ltd.)

Mating LVDS transmitter : THC63LVDM83A or equivalent device

Pin No.	Symbol	Function	Remark
1	VCC	+5V Power Supply	
2	VCC	+5V Power Supply	
3	VCC	+5V Power Supply	
4	VCC	+5V Power Supply	
5	GND		
6	GND		
7	GND		
8	GND		
9	SELLVDS	Select LVDS data order 【Note1】	Pull up Default H:3.3V
10	NC		
11	GND		
12	RIN0-	Negative (-) LVDS differential data input	LVDS
13	RIN0+	Positive (+) LVDS differential data input	LVDS
14	GND		
15	RIN1-	Negative (-) LVDS differential data input	LVDS
16	RIN1+	Positive (+) LVDS differential data input	LVDS
17	GND		
18	RIN2-	Negative (-) LVDS differential data input	LVDS
19	RIN2+	Positive (+) LVDS differential data input	LVDS
20	GND		
21	CLKIN-	Clock Signal(-)	LVDS
22	CLKIN+	Clock Signal(+)	LVDS
23	GND		
24	RIN3-	Negative (-) LVDS differential data input	LVDS
25	RIN3+	Positive (+) LVDS differential data input	LVDS
26	GND		
27	R/L	Horizontal shift direction 【Note 2】	
28	U/D	Vertical shift direction 【Note 2】	
29	TEST1	Fix to GND level usually.	
30	TEST2	Fix to GND level usually .	

【Note】

1. Shield case on the back surface of module contacts to GND of internal circuit.
2. It is recommend to connect all the GND terminals because of stable operation.

【Note1】 SELLVDS

Transmitter		SELLVDS	
Pin No	Data	=L(GND)	=H(3.3V) or Open
51	TA0	R0(LSB)	R2
52	TA1	R1	R3
54	TA2	R2	R4
55	TA3	R3	R5
56	TA4	R4	R6
3	TA5	R5	R7(MSB)
4	TA6	G0(LSB)	G2
6	TB0	G1	G3
7	TB1	G2	G4
11	TB2	G3	G5
12	TB3	G4	G6
14	TB4	G5	G7(MSB)
15	TB5	B0(LSB)	B2
19	TB6	B1	B3
20	TC0	B2	B4
22	TC1	B3	B5
23	TC2	B4	B6
24	TC3	B5	B7(MSB)
27	TC4	NA	NA
28	TC5	NA	NA
30	TC6	DE	DE
50	TD0	R6	R0(LSB)
2	TD1	R7(MSB)	R1
8	TD2	G6	G0(LSB)
10	TD3	G7(MSB)	G1
16	TD4	B6	B0(LSB)
18	TD5	B7(MSB)	B1
25	TD6	NA	NA

Interface block diagram

Corresponding Transmitter:THC63LVDM83A(THine).

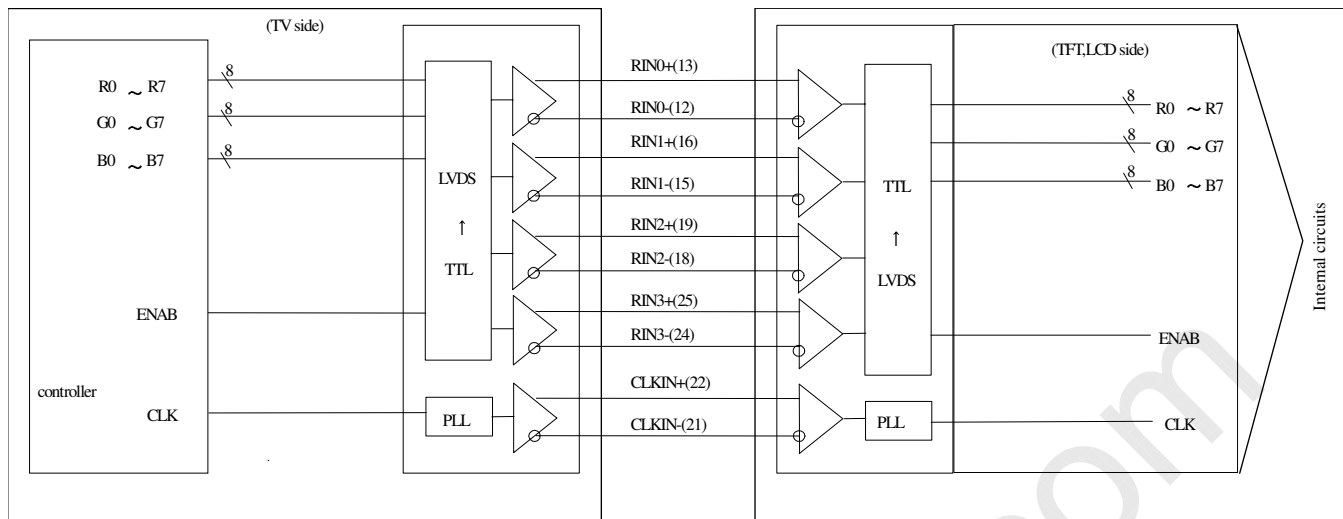

Input block diagram

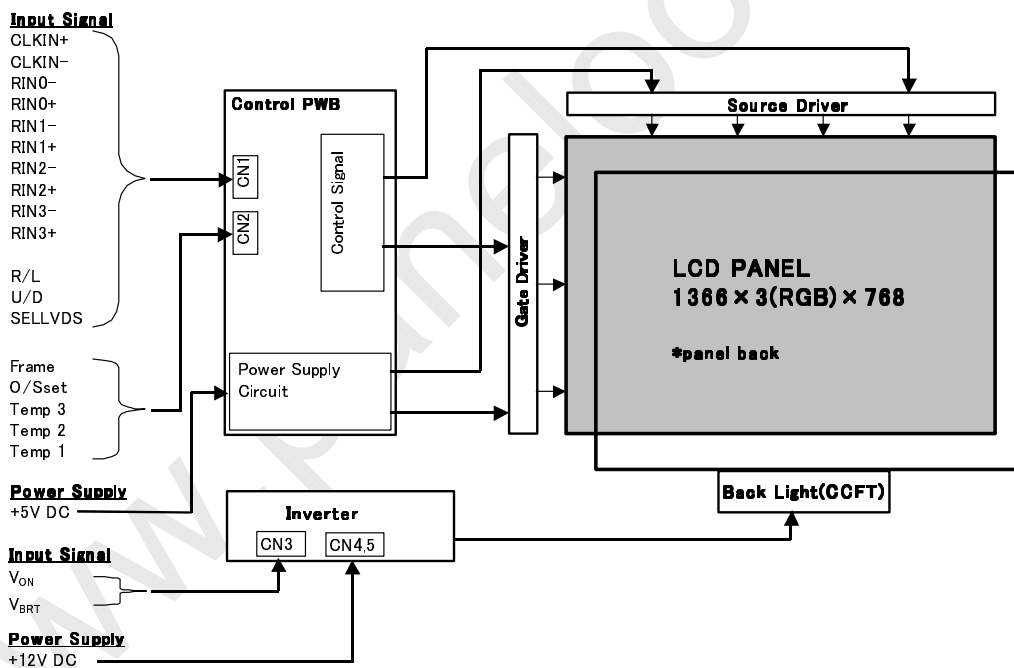

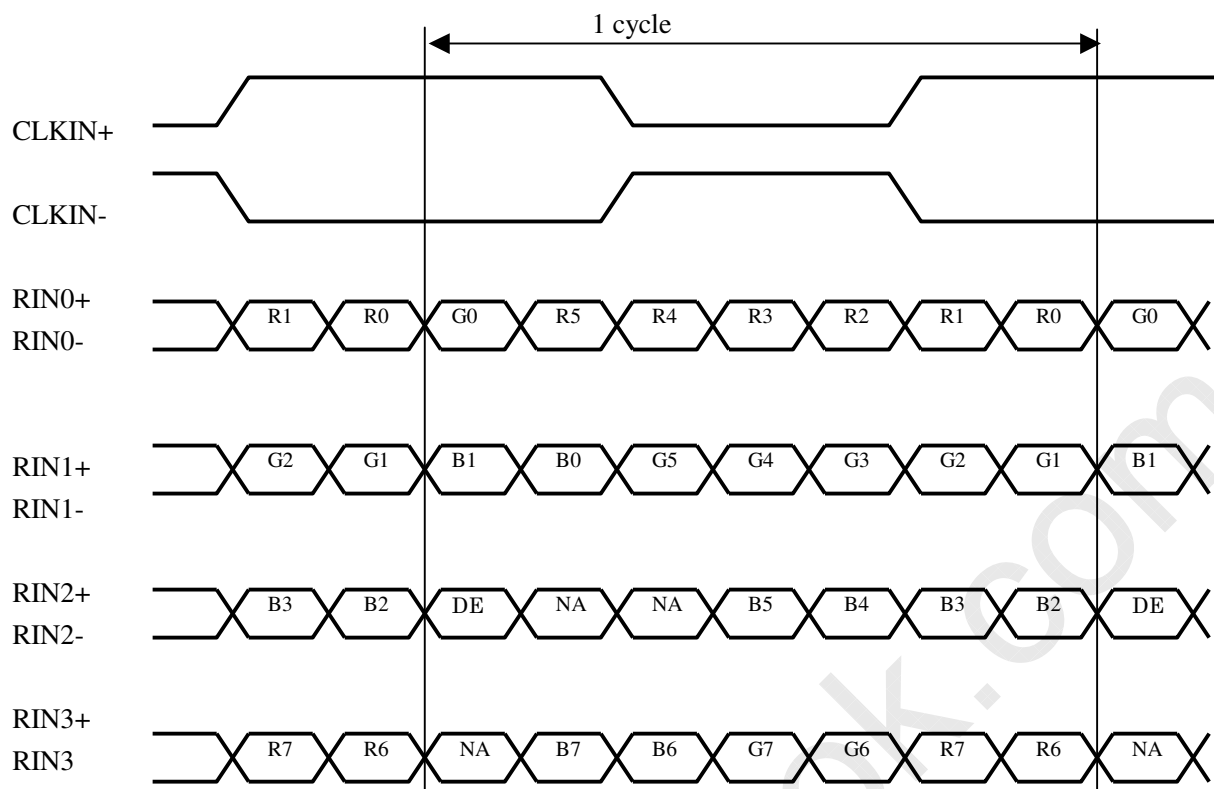
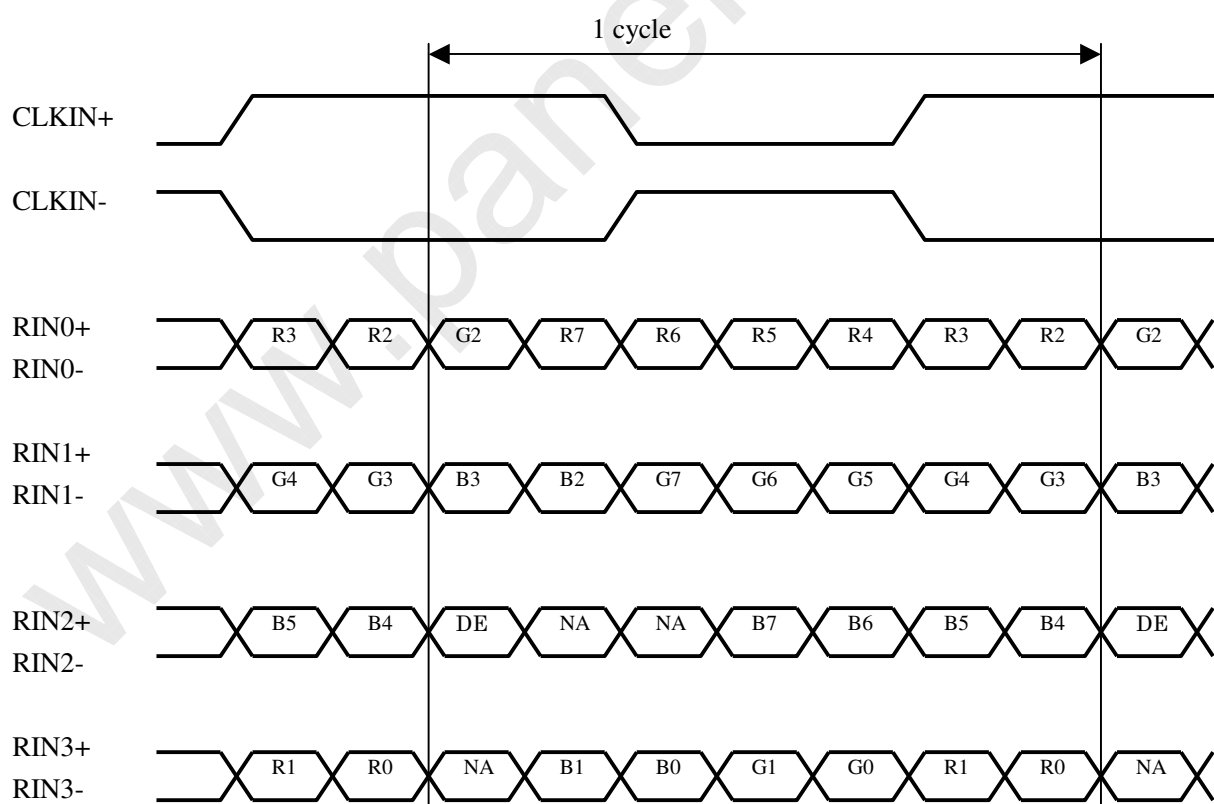
SELLVDS= Low(GND)**SELLVDS= High(3.3V) or Open**

DE: Display Enable

NA: Not Available (Fixed Low)

【Note 2】

Normal (Default)
R/L : L (GND) U/D:L (GND)

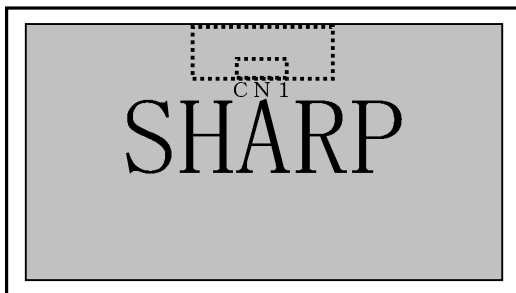

Reversed image with horizontal
R/L : H (3.3V) U/D : L (GND)

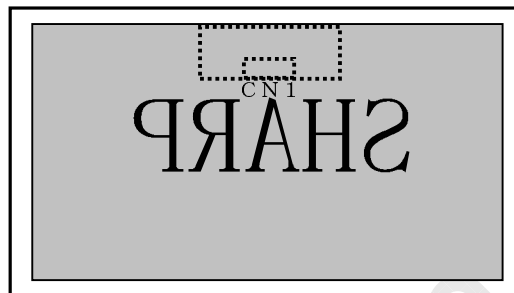

Reversed image with vertical
R/L : L (GND) U/D:H (3.3V)

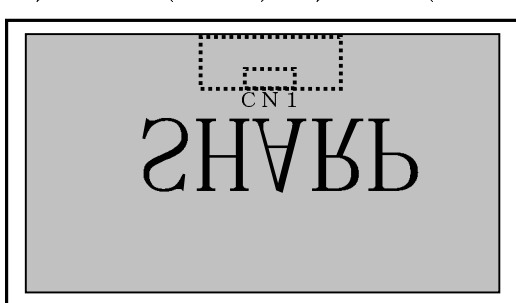

Reversed image with horizontal and vertical
R/L : H (3.3V) U/D:H (3.3V)

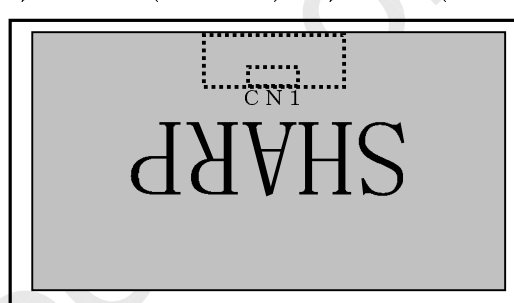

CN2(O/S control) -(Shown in Fig 1)

OS Driving Pin No. and function

Using connector : SM07B-SRSS-TB-A (JST)

Mating connector : SHR-07V-S or SHR-07V-S-B (JST)

0: (GND) ,1: (3.3V)

Pin No.	Symbol	Function	Default
1	Frame	Frame frequency setting 1:60Hz, 0:50Hz	Pull down(10k ohm)
2	O/Sset	O/S operation setting 1:OS_ON, 0:OS_OFF	Pull down(10k ohm) 【Note 1】
3	TEST3	Fix to GND level usually.	Pull down(30k ohm) 【Note 1】
4	Temp3	Data3 of panel surface temperature	Pull down(10k ohm)
5	Temp2	Data2 of panel surface temperature	Pull down(10k ohm)
6	Temp1	Data1 of panel surface temperature	Pull down(10k ohm)
7	GND		

【Note 1】 In case of O/S set setting "0"(O/S_OFF), it should be set the Temp1~3 to "0".

According as the surface temperature of the panel, enter the optimum 3 bit signal into pin No.4,5,6. Measuring the correlation between detected temperature by the sensor on PWB in users side and actual surface temperature of panel at center , convert the temperature detected by the sensor to the surface temperature of panel to enter the 3 bit temperature data.

Pin no.	Surface temperature of panel							
	0-5℃	5-10℃	10-15℃	15-20℃	20-25℃	25-30℃	30-35℃	35℃ and above
4	0	0	0	0	1	1	1	1
5	0	0	1	1	0	0	1	1
6	0	1	0	1	0	1	0	1

*0 : Low level voltage(0V) 1 : High level voltage(3.3V)

*For overlapping temperatures (such as 5℃,10℃,15℃,20℃,25℃, 30℃,35℃) select the optimum parameter, judging from the actual picture image.

4-2. Backlight driving

CN3 (Inverter control) Using connector: S6B-PH-SM3-TB(JST) Mating connector: PHR-6 (JST)

Pin No.	Symbol	Function	Remark
1	V _{ON/OFF}	Inverter control	【Note 1】
2	V _{SEL}	Fix to 5V level usually.	
3	Reserved	OPEN	
4	V _{BRT}	Brightness Control	【Note 2】
5	Reserved	OPEN	
6	GND	Fix to GND level usually.	

*Shield case on the back surface of module doesn't contact to GND of internal circuit.

【Note 1】 V_{ON/OFF} (Inverter control)

Input voltage	Function
5V	Inverter: ON
0V	Inverter: OFF

【Note 2】 V_{BRT} (Brightness Control)

PWM Brightness Control is regulated by analog input voltage (0V to 5V) .

Input voltage	Function
5V	Brightness Control : Dark (PWM duty : 15%)
0V	Brightness Control : Bright (PWM duty : 100%)

CN4,CN5 (Inverter Power input Pin layout)

Using connector: B10B-PH-SM3-TB (JST)

Mating connector: PHR-10 (JST)

Pin No.	Symbol	Function
1	V _{INV}	+12V
2	V _{INV}	+12V
3	V _{INV}	+12V
4	V _{INV}	+12V
5	V _{INV}	+12V
6	GND	GND
7	GND	GND
8	GND	GND
9	GND	GND
10	GND	GND

* Shield case on the back surface of module doesn't contact to GND of internal circuit.

4-3. Lamp characteristics

The back light system is direct type with 16 CCFTs (Cold Cathode Fluorescent Tube).

The characteristics of the lamp are shown in the following table. The value mentioned below is at the case of one CCFT.

CCFT type : HARISON TOSHIBA LIGHTING, Corp. / WEST ELECTRIC CO.,LTD
/ STANLEY ELECTRIC CO.,LTD

Item	Symbol	Min.	Typ.	Max.	Unit	Remarks
Life time	T _L	60000	-	-	Hour	【Note 1】

【Note 1】 Above value is applicable when the long side of LCD module is placed horizontally (Landscape position). (Lamp lifetime may vary if LCD module is in portrait position due to the change of mercury density inside the lamp.)

Lamp life time is defined as the time when brightness becomes 50% of the original value in the continuous operation under the condition of Ta=25 °C and brightness control(V_{BRT}=0V).

5. Absolute Maximum Ratings

Parameter	Symbol	Condition	Ratings	Unit	Remark
Input voltage (for Control)	V _I	Ta=25 °C	-0.3 ~ 3.6	V	【Note 1】
5V supply voltage (for Control)	VCC	Ta=25 °C	0 ~ +6	V	
Input voltage (for Inverter)	V _{BRT} V _{ON/OFF} V _{SEL}	Ta=25 °C	0 ~ +6	V	
12V supply voltage (for Inverter)	V _{INV}	Ta=25 °C	0 ~ +14	V	
Storage temperature	T _{stg}	-	-25 ~ +60	°C	
Operation temperature (Ambient)	T _{opa}	-	0 ~ +50	°C	【Note 2】

【Note 1】 SELLVDS, R/L, U/D, TEST1, TEST2, TEST3, Frame, O/S set, Temp1, Temp2, Temp3

【Note 2】 Humidity 95%RH Max.(Ta≤40 °C)

Maximum wet-bulb temperature at 39 °C or less.(Ta>40 °C) No condensation.

6. Electrical Characteristics

6-1. Control circuit driving

Ta=25 °C

Parameter	Symbol	Min.	Typ.	Max.	Unit	Remark	
+5V supply voltage	Supply voltage	V _{CC}	+4.5	+5.0	+5.5	V	【Note 1】
	Current dissipation	I _{CC}	-	1.7	2.5	A	【Note 2】
Permissible input ripple voltage	V _{RP}	-	-	100	mV _{P-P}	V _{CC} = +5.0V	
Differential input threshold voltage	High	V _{TH}	-	-	100	mV	V _{CM} = +1.2V 【Note 6】
	Low	V _{TL}	-100	-	-	mV	
Input Low voltage	V _{IL}	-	-	1.0	V	【Note 3】	
Input High voltage	V _{IH}	2.3	-	3.3	V		
Input leak current (Low)	I _{IL1}	-	-	100	μA	V _I = 0V 【Note 4】	
	I _{IL2}	-	-	400	μA	V _I = 0V 【Note 5】	
Input leak current (High)	I _{IH1}	-	-	100	μA	V _I = 3.3V 【Note 4】	
	I _{IH2}	-	-	400	μA	V _I = 3.3V 【Note 5】	
Terminal resistor	R _T	-	100	-	Ω	Differential input	

【Note】 V_{CM}: Common mode voltage of LVDS driver.

【Note 1】

1) Input voltage sequences

$$0 < t_1 \leq 10\text{ms}, \quad 0 < t_2-1 \leq 20\text{ms}$$

$$t_2-2 \geq 10\text{ms}, \quad 0 < t_3 \leq 1\text{s},$$

$$t_4 \geq 1\text{s}, \quad 200\text{ms} \leq t_5$$

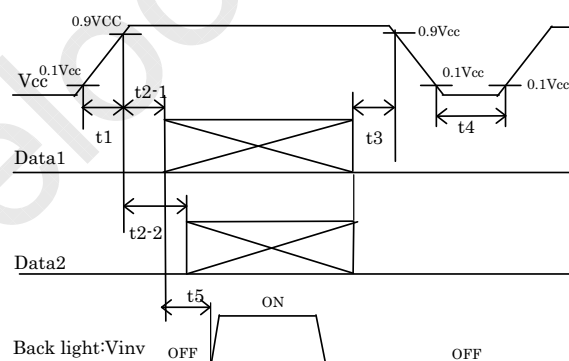

※ Data1 : CLKIN±, RIN0±, RIN1±, RIN2±, RIN3±

※ Data2 : R/L, U/D, SELLVDS, Frame, O/Sset, Temp1,2,3

2) Dip conditions for supply voltage

a) $2.7\text{V} \leq V_{CC} < 4.5\text{V}$

$$t_d \leq 10\text{ms}$$

b) $V_{CC} < 2.7\text{V}$

Dip conditions for supply voltage is based on input voltage sequence.

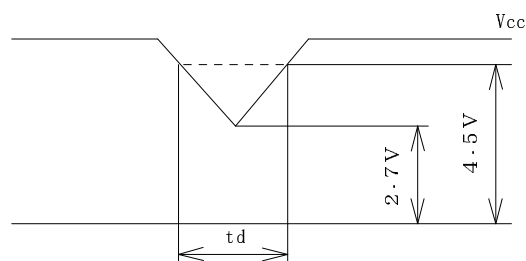

【Note 2】 Typical current situation: 256 gray-bar pattern (Vcc = +5.0V)

The explanation of RGB gray scale is seen in section 8.

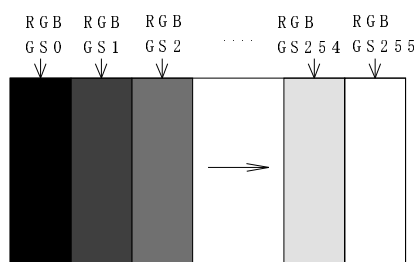

Vcc=5.0V
CK=82.0MHz
Th=20.67 μs

【Note 3】 R/L, U/D, SELLVDS, TEST1, TEST2, TEST3, Frame, O/Sset, Temp1, Temp2, Temp3

【Note 4】 R/L, U/D

【Note 5】 SELLVDS, TEST1, TEST2, TEST3, Frame, O/Sset, Temp1, Temp2, Temp3

【Note 6】 CKIN±, RIN0±, RIN1±, RIN2±, RIN3±

6-2. Inverter driving for back light

The back light system is under-lighting type with 16 CCFTs (Cold Cathode Fluorescent Tube).

Ta=25°C

Parameter	Symbol	Min.	Typ.	Max.	Unit	Remark
+12V Current dissipation	IINV1	-	11	12	A	VINV = 12V VBRT = 0V, VON/OFF=5V 【Note 4】
	IINV2	-	8.5	9.2	A	
	Supply voltage	VINV	11.0	12.0	13.0	V
Permissible input ripple voltage	VRIF	-	-	200	mV _{p-p}	VINV = +12V
Input voltage (Low)	VONL	0	-	1.0	V	【Note2】 Input Impedance 24KΩ
Input voltage (High)	VONH	3.0	5.0	6.0	V	
	VSEL	3.0	5.0	6.0	V	Input Impedance 20KΩ
Brightness control voltage	VBRT	0	→	5	V	【Note3】 Input Impedance 112KΩ
Brightness control voltage Vs Burst Duty Ratio		95	→	15	%	

【Note 1】 1)VINV-turn-on condition

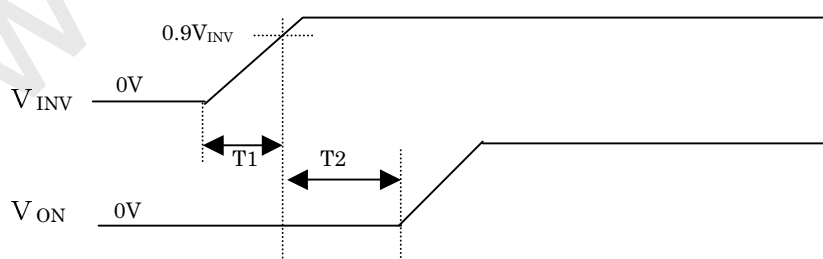

※ T1 > 100 μs

※ T2 > 1ms

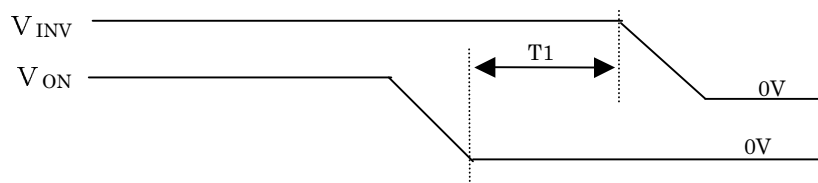
2) V_{INV} -turn-off condition

※ $T1 > 1ms$

【Note 2】 V_{ON}

【Note 3】 V_{BRT}

【Note 4】 I_{INV1} : The current value of less than 1 hour after switching on the light.

I_{INV2} : The current value after 1 hour or more have passed since the light was switched on the light.

【Note】 The performance of the backlight, for example life time or brightness, is much influenced by the characteristics of the power supply for the inverter. When you design or order the power supply for the inverter, please make sure that a poor lighting caused by the mismatch of the backlight and the inverter (miss-lighting, flicker, etc.) never occur. When you confirm it, the module should be operated in the same condition as it is installed in your instrument. Also, the power supply for the inverter use the one which has safe protection circuits such as the circuit of the detection of the overvoltage / the overcurrent.

7. Timing characteristics of input signals

7-1. Timing characteristics

Timing diagrams of input signal are shown in Fig.2

Parameter		Symbol	Min.	Typ.	Max.	Unit	Remark
Clock	Frequency	$1/T_c$	65	82	85	MHz	
Data enable signal	Horizontal period	TH	1560	1696	1940	clock	
			17.0	20.68	-	μs	
	Horizontal period (High)	THd	1366	1366	1366	clock	
	Vertical period	TV	778	806	972	line	【Note1】
	Vertical period (High)	TVd	768	768	768	line	

【Note】 It is recommend inputting a signal, after turning on a module back light.

【Note1】 When vertical period is very long, flicker and etc. may occur.

It is recommend making sure that length of vertical period is an integral multiple of horizontal length of period. Otherwise, the screen may not display properly.

【Note2】 Cut off the power supply after you make it black screen indications.

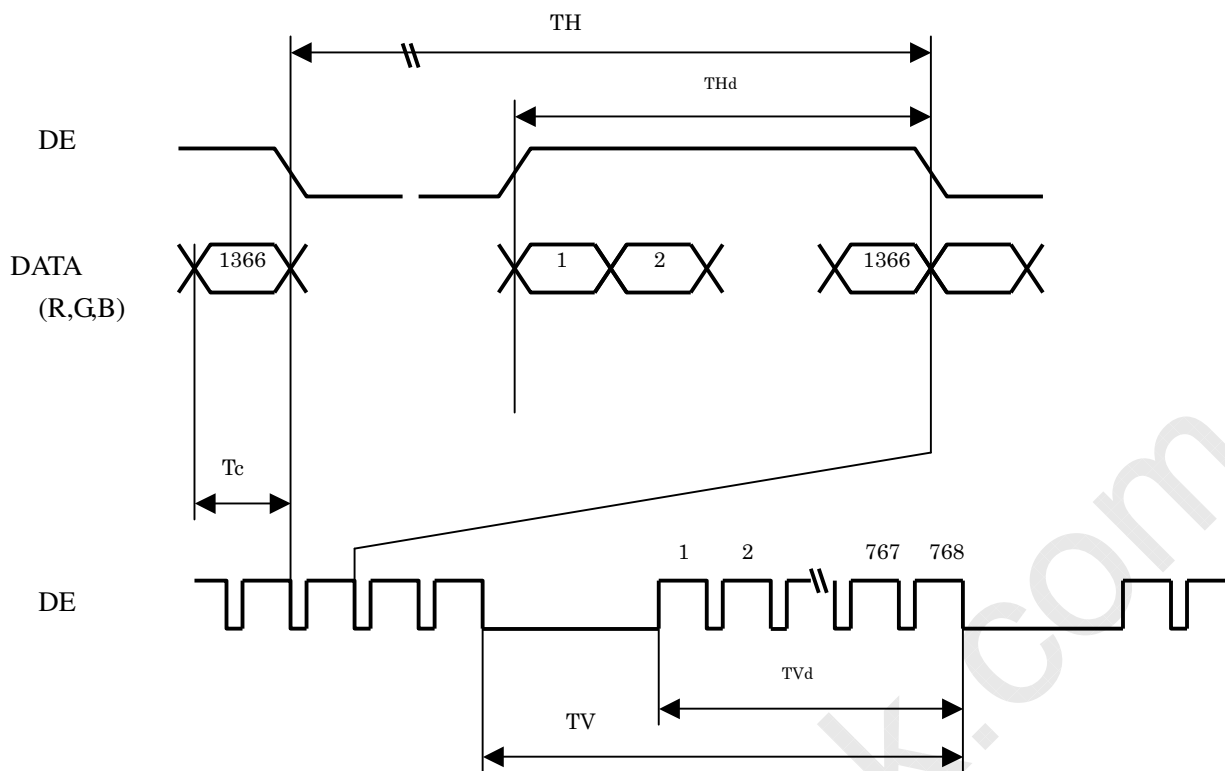

7-2. Input data signal and display position on the screen

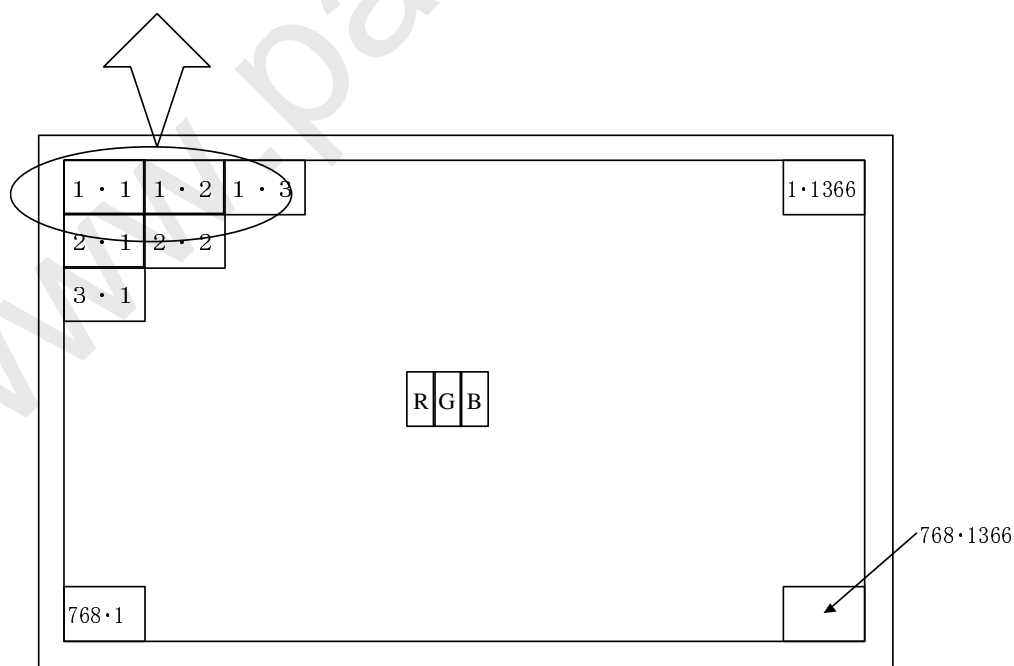
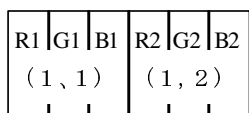

データの表示画面位置 (V,H)

8. Input Signal, Basic Display Colors and Gray Scale of Each Color

Colors & Gray scale	Data signal																									
	Gray Scale	R0	R1	R2	R3	R4	R5	R6	R7	G0	G1	G2	G3	G4	G5	G6	G7	B0	B1	B2	B3	B4	B5	B6	B7	
Basic Color	Black	—	0	0	0	0	0	0	0	0	0	0	0	0	0	0	0	0	0	0	0	0	0	0	0	0
	Blue	—	0	0	0	0	0	0	0	0	0	0	0	0	0	0	0	0	1	1	1	1	1	1	1	1
	Green	—	0	0	0	0	0	0	0	0	1	1	1	1	1	1	1	1	0	0	0	0	0	0	0	0
	Cyan	—	0	0	0	0	0	0	0	0	1	1	1	1	1	1	1	1	1	1	1	1	1	1	1	1
	Red	—	1	1	1	1	1	1	1	1	0	0	0	0	0	0	0	0	0	0	0	0	0	0	0	0
	Magenta	—	1	1	1	1	1	1	1	1	0	0	0	0	0	0	0	0	1	1	1	1	1	1	1	1
	Yellow	—	1	1	1	1	1	1	1	1	1	1	1	1	1	1	1	1	0	0	0	0	0	0	0	0
	White	—	1	1	1	1	1	1	1	1	1	1	1	1	1	1	1	1	1	1	1	1	1	1	1	1
Gray Scale of Red	Black	GS0	0	0	0	0	0	0	0	0	0	0	0	0	0	0	0	0	0	0	0	0	0	0	0	0
	↑	GS1	1	0	0	0	0	0	0	0	0	0	0	0	0	0	0	0	0	0	0	0	0	0	0	0
	Darker	GS2	0	1	0	0	0	0	0	0	0	0	0	0	0	0	0	0	0	0	0	0	0	0	0	0
	↑	↓				↓							↓								↓					
	↓	↓				↓							↓								↓					
	Brighter	GS253	1	0	1	1	1	1	1	1	0	0	0	0	0	0	0	0	0	0	0	0	0	0	0	0
	↓	GS254	0	1	1	1	1	1	1	1	0	0	0	0	0	0	0	0	0	0	0	0	0	0	0	0
	Red	GS255	1	1	1	1	1	1	1	1	0	0	0	0	0	0	0	0	0	0	0	0	0	0	0	0
Gray Scale of Green	Black	GS0	0	0	0	0	0	0	0	0	0	0	0	0	0	0	0	0	0	0	0	0	0	0	0	0
	↑	GS1	0	0	0	0	0	0	0	0	1	0	0	0	0	0	0	0	0	0	0	0	0	0	0	0
	Darker	GS2	0	0	0	0	0	0	0	0	0	1	0	0	0	0	0	0	0	0	0	0	0	0	0	0
	↑	↓				↓							↓								↓					
	↓	↓				↓							↓								↓					
	Brighter	GS253	0	0	0	0	0	0	0	0	1	0	1	1	1	1	1	1	0	0	0	0	0	0	0	0
	↓	GS254	0	0	0	0	0	0	0	0	0	1	1	1	1	1	1	1	0	0	0	0	0	0	0	0
	Green	GS255	0	0	0	0	0	0	0	0	1	1	1	1	1	1	1	1	0	0	0	0	0	0	0	0
Gray Scale of Blue	Black	GS0	0	0	0	0	0	0	0	0	0	0	0	0	0	0	0	0	0	0	0	0	0	0	0	0
	↑	GS1	0	0	0	0	0	0	0	0	0	0	0	0	0	0	0	0	1	0	0	0	0	0	0	0
	Darker	GS2	0	0	0	0	0	0	0	0	0	0	0	0	0	0	0	0	0	1	0	0	0	0	0	0
	↑	↓				↓							↓								↓					
	↓	↓				↓							↓								↓					
	Brighter	GS253	0	0	0	0	0	0	0	0	0	0	0	0	0	0	0	0	1	0	1	1	1	1	1	1
	↓	GS254	0	0	0	0	0	0	0	0	0	0	0	0	0	0	0	0	0	1	1	1	1	1	1	1
	Blue	GS255	0	0	0	0	0	0	0	0	0	0	0	0	0	0	0	0	1	1	1	1	1	1	1	1

0 : Low level voltage, 1 : High level voltage.

Each basic color can be displayed in 256 gray scales from 8 bit data signals. According to the combination of total 24 bit data signals, the 16,777,216 colors display can be achieved on the screen.

9. Optical characteristics

Ta=25°C, VCC = +5.0V, VINV = +12.0V, Timing characteristics of input signals: Typical value

Parameter		Symbol	Condition	Min.	Typ.	Max.	Unit	Remark
Viewing angle range	Horizontal	θ_{21} θ_{22}	CR \geq 10	70	85	-	Deg.	【Note1,4】 V _{BRT} = 0V
	Vertical	θ_{11} θ_{12}						
Contrast ratio		CRn		600	800	-		【Note2,4】 V _{BRT} = 0V
Response time		τ_r τ_d		-	15	45	ms	【Note3,4,5】 V _{BRT} = 0V
Chromaticity	white	Wx	$\theta = 0 \text{ deg.}$	0.242	0.272	0.302	-	【Note 4】 V _{BRT} = 0V
		Wy		0.247	0.277	0.307	-	
	red	Rx		0.610	0.640	0.670	-	
		Ry		0.300	0.330	0.360	-	
	green	Gx		0.250	0.280	0.310	-	
		Gy		0.570	0.600	0.630	-	
	blue	Bx		0.120	0.150	0.180	-	
		By		0.030	0.060	0.090	-	
Luminance of white		Y _L		400	500	-	cd/m ²	
Luminance uniformity		δ_w		-	-	1.25	-	
								【Note 6】 V _{BRT} = 0V

Measurement condition : Set the value of V_{BRT} to maximum luminance of white.

*The measurement shall be executed more than 60 minutes after lighting at rating.

【Note】 The optical characteristics are measured using the following equipment.

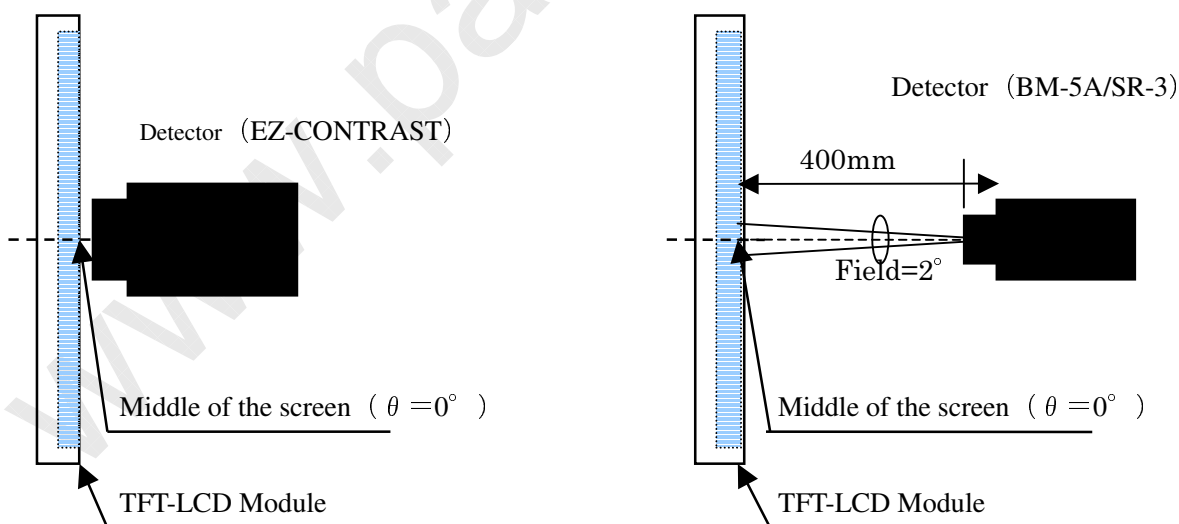

Response time : BM-5A

Viewing angle range : EZ-CONTRAST

Luminance, Chromaticity, Contrast : SR-3

Fig.3 Measurement method of optical characteristic

【Note 1】 Definitions of viewing angle range :

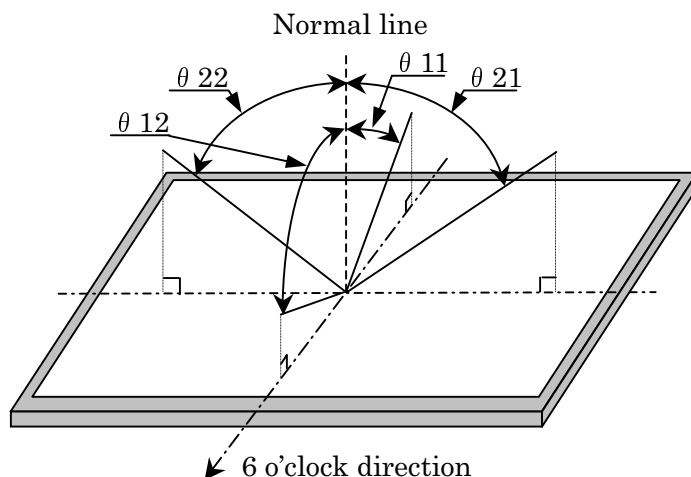

【Note 2】 Definition of contrast ratio :

The contrast ratio is defined as the following.

$$\text{Contrast Ratio} = \frac{\text{Luminance(brightness) with all pixels white}}{\text{Luminance(brightness) with all pixels black}}$$

【Note 3】 Definition of response time

The response time is defined as the following figure and shall be measured by switching the input signal for “any level of gray (bright)” and “any level of gray (dark)”.

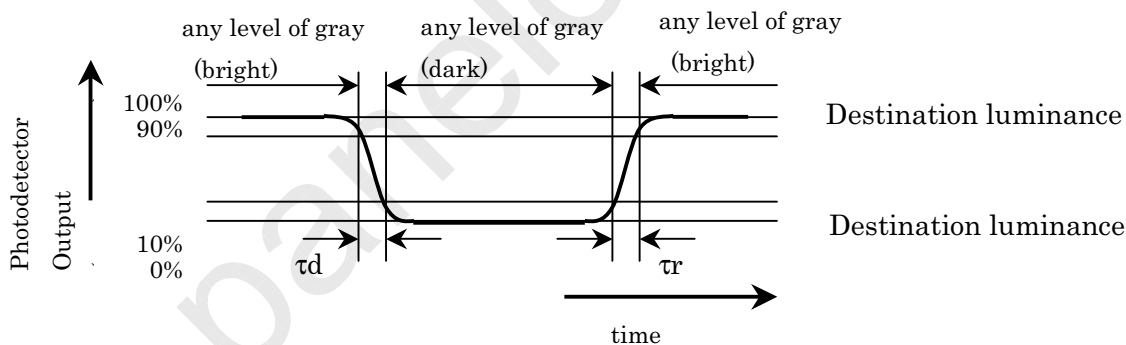

【Note 4】 This shall be measured at center of the screen.

【Note 5】 ”15ms” is the value when O/S driving is used at typical input time value .

【Note 6】 Definition of white uniformity ;

White uniformity is defined as the following with five measurements.(A~E)

$$\delta_w = \frac{\text{maximum luminance of five point(brightness)}}{\text{minimum luminance of five point(brightness)}}$$

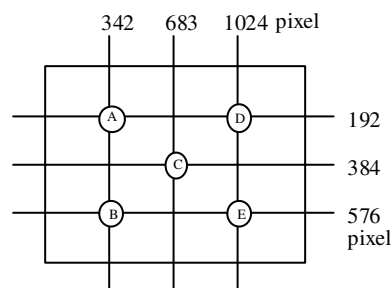

10. Handling Precautions of the module

- Be sure to turn off the power supply when inserting or disconnecting the cable.
- This product is using the parts(inverter, CCFT etc) which generate the high voltage. Therefore, during operating, please don't touch these parts.
- Brightness control voltage is switched for "ON" and "OFF", as shown in Fig.4. Voltage difference generated by this switching, ΔV_{INV} , may affect a sound output, etc. when the power supply is shared between the inverter and its surrounding circuit. So, separate the power supply of the inverter circuit with the one of its surrounding circuit.

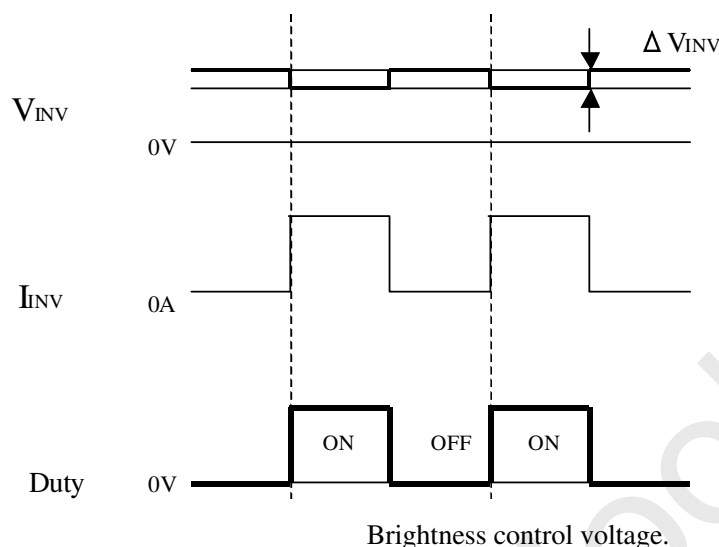

Since inverter board's GND is not connected to the frame of the LCD module, please connect it with the Customer's GND of inverter power supply.

- Be sure to design the cabinet so that the module can be installed without any extra stress such as warp or twist.
- Since the front polarizer is easily damaged, pay attention not to scratch it.
- Since long contact with water may cause discoloration or spots, wipe off water drop immediately.
- When the panel surface is soiled, wipe it with conventional Display cloth such as absorbent cotton or other soft cloth.
- Since the panel is made of glass, it may break or crack if dropped or bumped on hard surface. Handle with care.
- Since CMOS LSI is used in this module, take care of static electricity and take the human earth into consideration when handling.
- The module has some printed circuit boards (PCBs) on the back side, take care to keep them form any stress or pressure when handling or installing the module; otherwise some of electronic parts on the PCBs may be damaged.
- Observe all other precautionary requirements in handling components.
- When some pressure is added onto the module from rear side constantly, it causes display non-uniformity issue, functional defect, etc.. So, please avoid such design.
- When giving a touch to the panel at power on supply, it may cause some kinds of degradation. In that case, once turn off the power supply, and turn on after several seconds again, and that is disappear.

- n) When handling LCD modules and assembling them into cabinets, please be noted that long-term storage in the environment of oxidization or deoxidization gas and the use of such materials as reagent, solvent, adhesive, resin, etc. which generate these gasses, may cause corrosion and discoloration of the LCD modules.

11. Packing form

- a) Piling number of cartons: 2 maximum
 - b) Packing quantity in one carton: 5 pcs
 - c) Carton size: 970 mm(W) x 630 mm(D) x 740m(H)
 - d) Total mass of one carton filled with full modules: 80kg(Max)
- Packing form figures are shown in Fig.4

12. Reliability test item

No.	Test item	Condition
1	High temperature storage test	Ta=60°C 240h
2	Low temperature storage test	Ta=-25°C 240h
3	High temperature and high humidity operation test	Ta=40°C ; 95%RH 240h (No condensation)
4	High temperature operation test	Ta=50°C 240h
5	Low temperature operation test	Ta=0°C 240h
6	Vibration test (non-operation)	Frequency : 10~57Hz/Vibration width(one side) : 0.075mm : 58~500Hz/Acceleration : 9.8 m/s ² Sweep time: 11 minutes Test period : 3 hours(1h for each direction of X,Y,Z)
7	Shock test (non-operation)	Maximum acceleration : 490m/s ² Pulse width : 11ms,sinusoidal half wave Direction : +/-X,+/-Y,+/-Z,once for each direction.
8	ESD	* At the following conditions, it is a thing without incorrect operation and destruction. (1)Non-operation: Contact electric discharge ±10kV Non-contact electric discharge ±20kV (2)Operation Contact electric discharge ±8kV Non-contact electric discharge ±15kV Conditions: 150pF、330ohm

【Result evaluation criteria】

Under the display quality test condition with normal operation state, there shall be no change which may affect practical display function.

13. Others

1) Lot No. Label ;

It sticks the label which displayed SHARP, product model (LQ315T3LZ14), a product number and MADE IN JAPAN in the module surface.

A) The module which used the source driver made by Oki Electric Industry Co.,Ltd

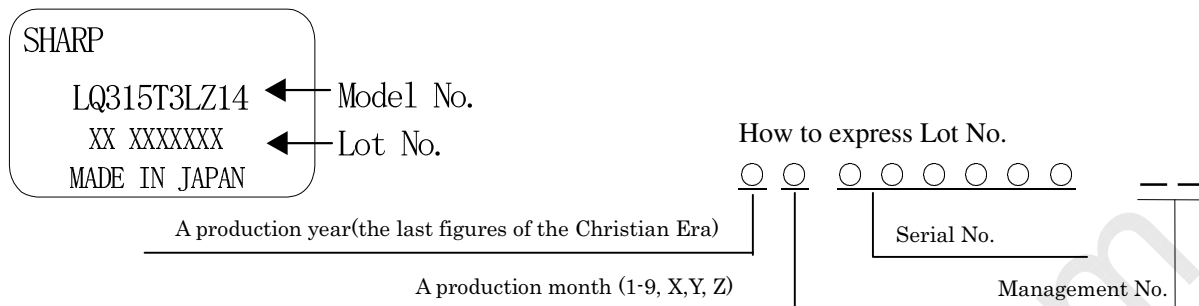

B) The module which used the source driver made by SHARP corporation

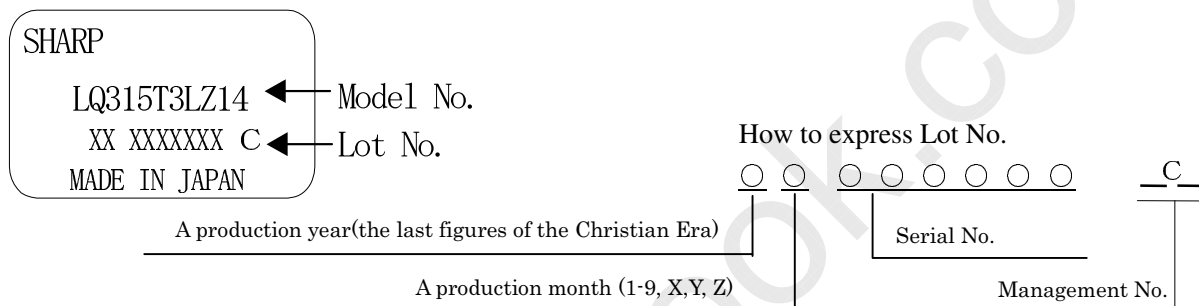

2) Packing Label

A) The module which used the source driver made by Oki Electric Industry Co.,Ltd

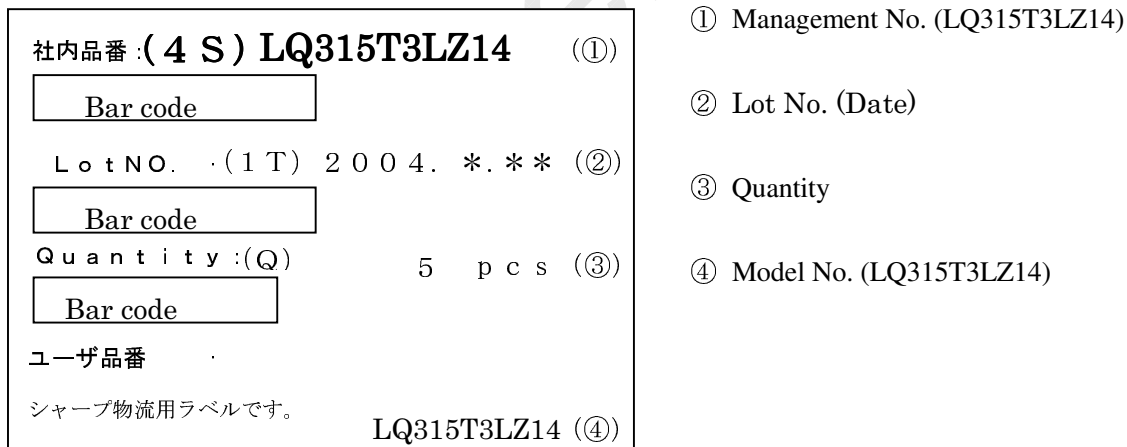

B) The module which used the source driver made by SHARP corporation

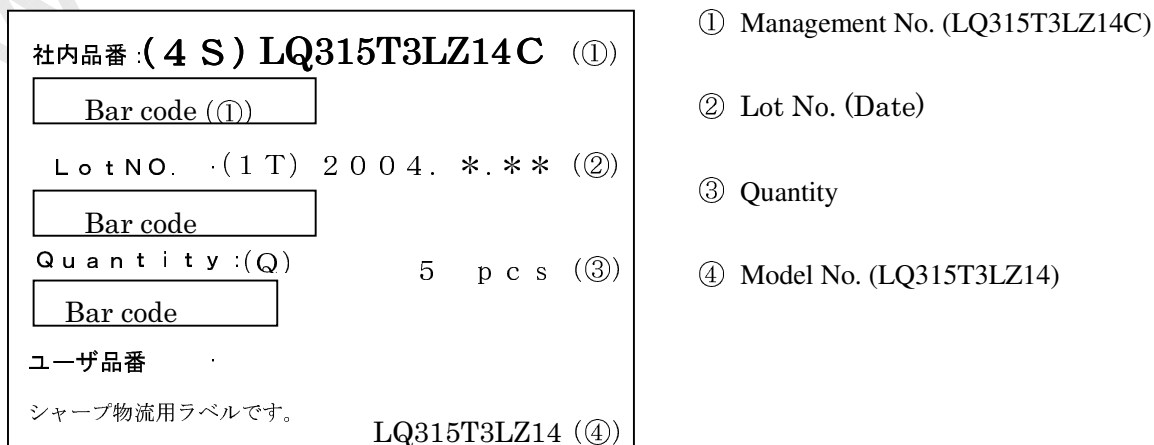

- 3) Adjusting volume have been set optimally before shipment, so do not change any adjusted value.
If adjusted value is changed, the specification may not be satisfied.
- 4) Disassembling the module can cause permanent damage and should be strictly avoided.
- 5) Please be careful since image retention may occur when a fixed pattern is displayed for a long time.
- 6) The chemical compound which causes the destruction of ozone layer is not being used.
- 7) Label of using material information

It is displaying the material of the optical parts with the label in the module back.

MATERIAL INFORMATION	
OPTICAL FILM	:> PC, PEST, AKUR-X, PC <
LENS FILM	:> PET, AK-X <
DIFFUSER SHEET	:> PET <
DIFFUSER BOARD	:> MMA/S <
REFLECTOR	:> PET <

- 8) Cold cathode fluorescent lamp in LCD PANEL contains a small amount of mercury. Please follow local ordinances or regulations for disposal.

	HIGH VOLTAGE
	CAUTION
<small>RISK OF ELECTRIC SHOCK. DISCONNECT THE ELECTRIC POWER BEFORE SERVICING.</small>	
<small>·COLD CATHODE FLUORESCENT LAMP IN LCD PANEL CONTAINS A SMALL AMOUNT OF MERCURY. PLEASE FOLLOW LOCAL ORDINANCES OR REGULATIONS FOR DISPOSAL. ·当該液晶ディスプレイパネルは蛍光管が組込まれていますので、地方自 治体の条例、または、規則に従って廃棄してください。</small>	

- 9) When any question or issue occurs, it shall be solved by mutual discussion.

-Packing Barcode Label-

社内品番: (4S) LQ315T3LZ14	(0)
LotNO: (1T) 2004. 3. 8 1	(0)
Quantity: (Q) 5 pcs	(0)
ユーザー品番:	
シール印刷用テキスト: LQ315T3LZ14	(0)

①Management Number (LQ315T3LZ14)
 ②Lot No. (Date)
 ③Quantity
 ④Model No. (LQ315T3LZ14)

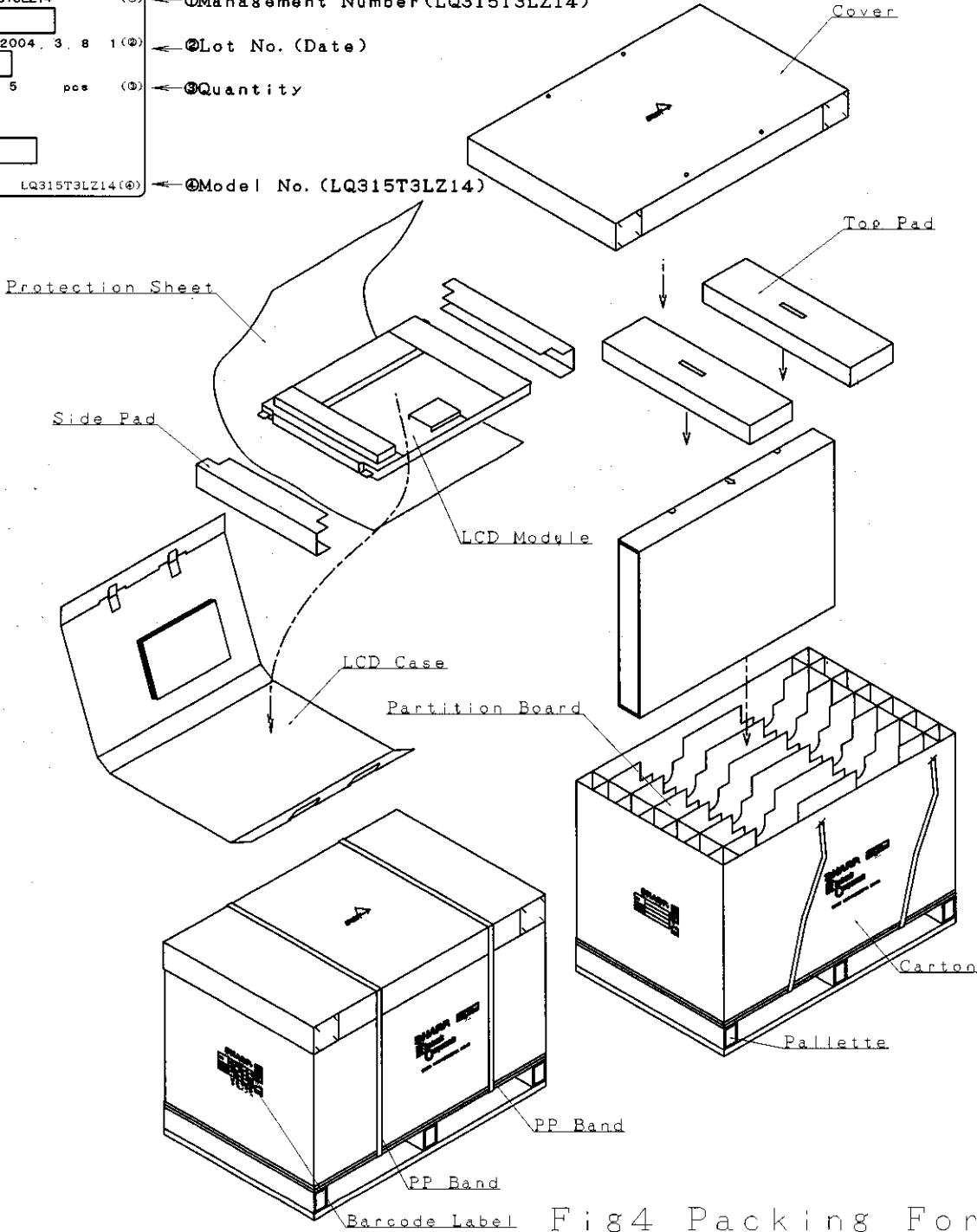
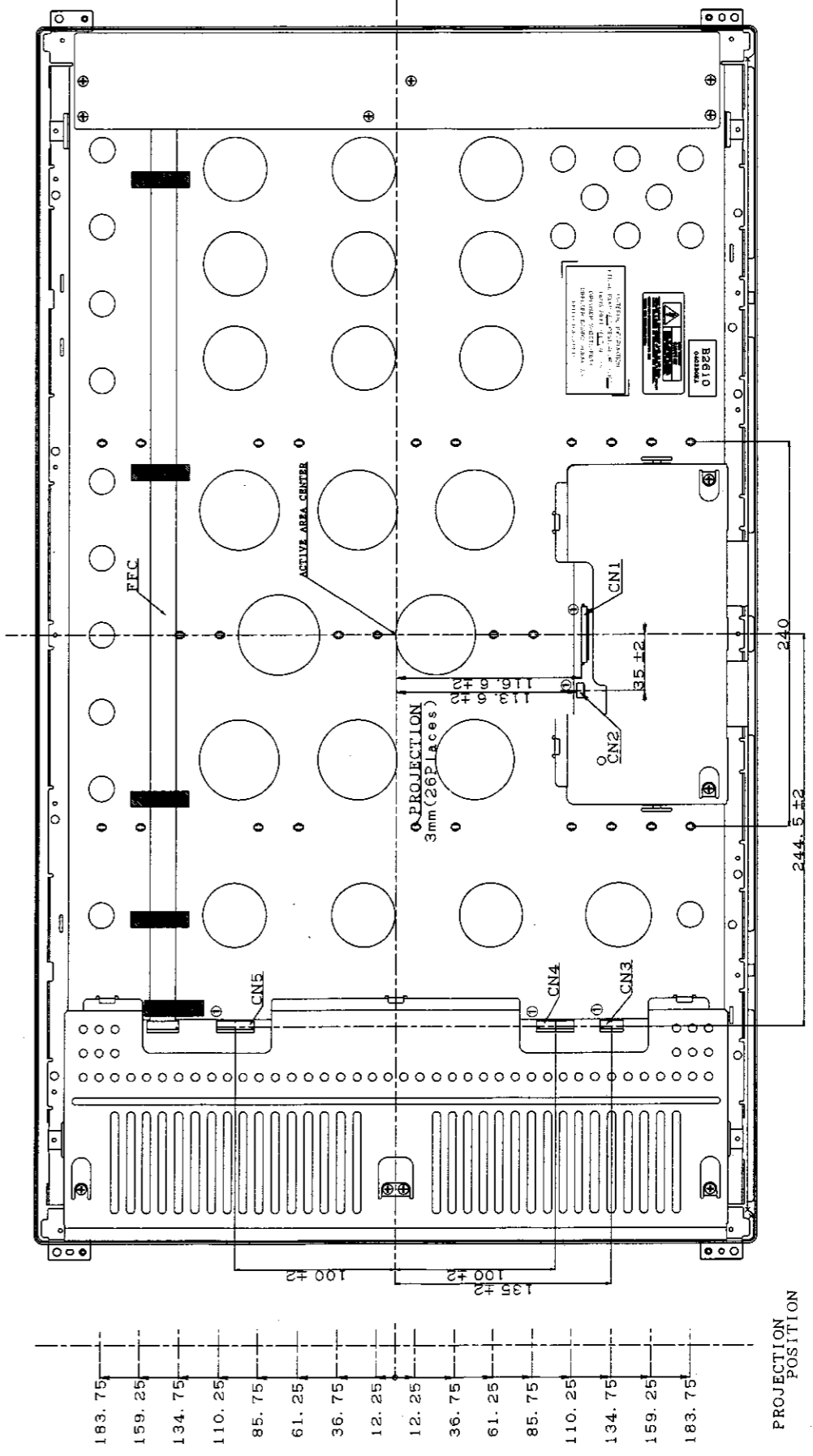
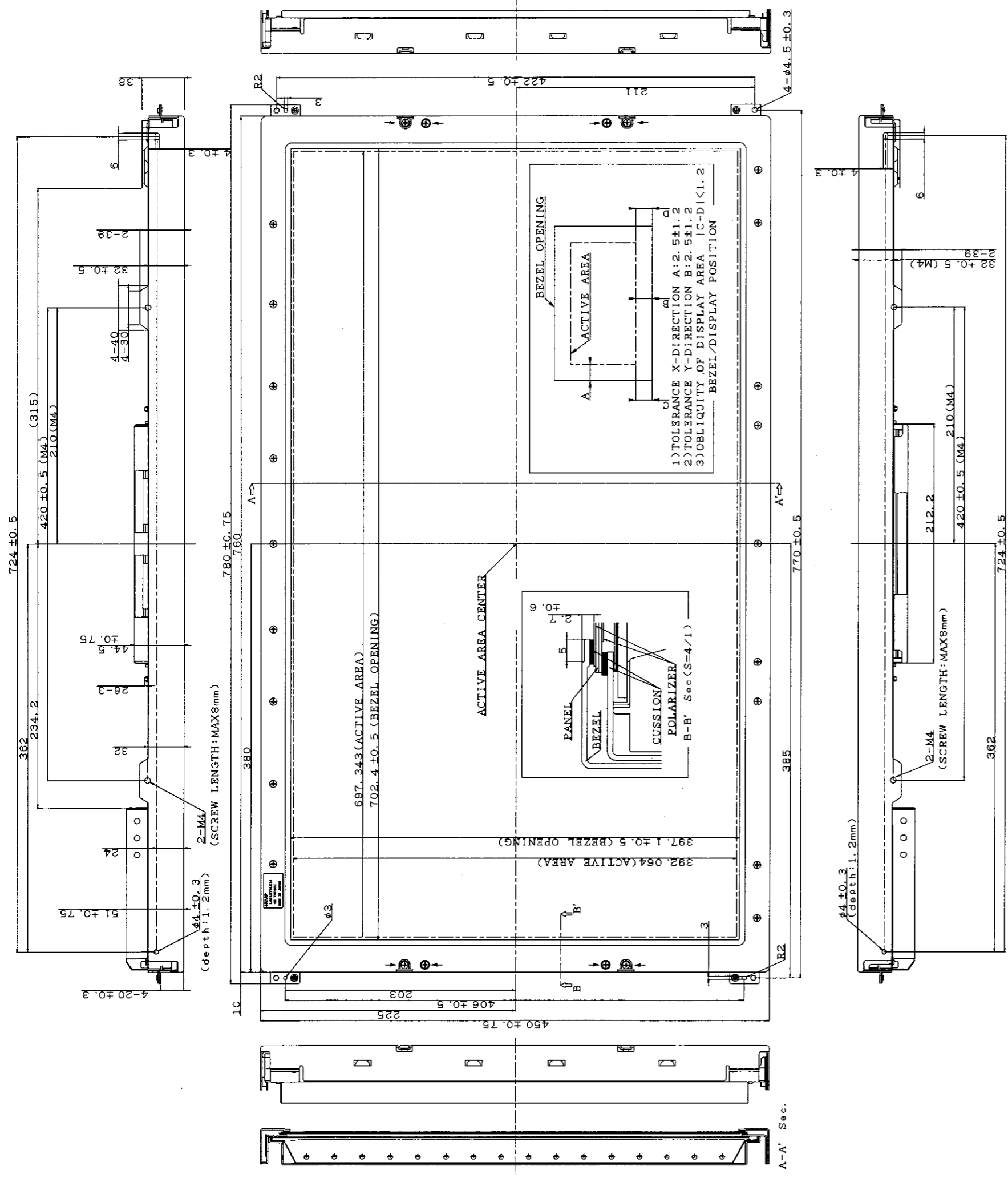

Fig4 Packing Form



1. UNSPECIFIED TOLERANCE TO BE ± 1.0

- CN1: F1-X30SSL-HF (JAE)
- CN2: SMTB-SRSS (JST)
- CN3: B6B-PH-SM3-TB (JST)
- CN4: B10B-PH-SM3-TB (JST)
- CN5: B10B-PH-SM3-TB (JST)

Fig 1. LQ315T3LZ14 TFT-LCD MODULE OUTLINE DIMENSIONS

PROJECTION POSITION