

| | | | |
|--------------------|------------|---|---|
| PREPARED BY: _____ | DATE _____ | SHARP | SPEC No. LD-17716B |
| APPROVED BY: _____ | DATE _____ | | FILE No. _____ |
| | | | ISSUE: Mar., 28, 2006 |
| | | | PAGE : 23 pages |
| | | AVC LIQUID CRYSTAL DISPLAY GROUP SHARP CORPORATION SPECIFICATION | APPLICABLE GROUP AVC LIQUID CRYSTAL DISPLAY GROUP |

DEVICE SPECIFICATION FOR
TFT - LCD module
 MODEL No. LQ370D3LZ14

CUSTOMER'S APPROVAL

DATE _____

BY _____

PRESENTED

BY *S. Uehira*

S. UEHIRA
 Department General manager
 Development Engineering Dept. 4
 DEVELOPMENT CENTER
 AVC LIQUID CRYSTAL DISPLAY GROUP
 SHARP CORPORATION

1. Application

This specification applies to the color 37.0" TFT-LCD module LQ370D3LZ14.

(Sharp management number of Short cut process panel model is "LQ370D3LZ14B") B

* These specification sheets are proprietary products of SHARP CORPORATION ("SHARP") and include materials protected under copyright of SHARP. Do not reproduce or cause any third party to reproduce them in any form or by any means, electronic or mechanical, for any purpose, in whole or in part, without the express written permission of SHARP.

* In case of using the device for applications such as control and safety equipment for transportation (aircraft, trains, automobiles, etc.), rescue and security equipment and various safety related equipment which require higher reliability and safety, take into consideration that appropriate measures such as fail-safe functions and redundant system design should be taken.

* Do not use the device for equipment that requires an extreme level of reliability, such as aerospace applications, telecommunication equipment (trunk lines), nuclear power control equipment and medical or other equipment for life support.

* SHARP assumes no responsibility for any damage resulting from the use of the device that does not comply with the instructions and the precautions specified in these specification sheets.

* Contact and consult with a SHARP sales representative for any questions about this device.

2. Overview

This module is a color active matrix LCD module incorporating amorphous silicon TFT (Thin Film Transistor). It is composed of a color TFT-LCD panel, driver ICs, control circuit, power supply circuit, inverter circuit and back light system etc. Graphics and texts can be displayed on a 1920 × RGB × 1080 dots panel with 16,777,216 colors by using LVDS (Low Voltage Differential Signaling) to interface, +12V of DC supply voltages.

This module also includes the DC/AC inverter to drive the CCFT. (+24V of DC supply voltage)

And in order to improve the response time of LCD, this module applies the Over Shoot driving (O/S driving) technology for the control circuit. In the O/S driving technology, signals are being applied to the Liquid Crystal according to a pre-fixed process as an image signal of the present frame when a difference is found between image signal of the previous frame and that of the current frame after comparing them.

By using the captioned process, the image signals of this LCD module are being set so that image response can be completed within one frame, as a result, image blur can be improved and clear image performance can be realized.

3. Mechanical Specifications

| Parameter | Specifications | Unit |
|------------------------------|---|-------|
| Display size | 94.0 (Diagonal) | cm |
| | 37.0 (Diagonal) | inch |
| Active area | 819.4(H) x 460.9 (V) | mm |
| Pixel Format | 1920(H) x 1080(V) (1pixel = R + G + B dot) | pixel |
| Pixel pitch | 0.42675(H) x 0.42675 (V) | mm |
| Pixel configuration | R, G, B vertical stripe | |
| Display mode | Normally black | |
| Unit Outline Dimensions (*1) | 877.0(W) x 516.0(H) x 56.0(D) | mm |
| Mass | 8.0 ± 0.3 | Kg |
| Surface treatment | Anti glare, low reflection coating Hard coating: 2H Haze: 23 +/- 5% | |

(*1) Outline dimensions are shown in Fig.1

4. Input Terminals

4-1. TFT panel driving

CN1 (Interface signals and +12V DC power supply) (Shown in Fig.1)

Using connector : (LQ370D3LZ14)SM30B-LDYGLS (J.S.T. Mfg Co.,Ltd.)

(LQ370D3LZ14B)FI-X30SSL-HF(Japan Aviation Electronics Ind. , Ltd.)

Mating connector :FI-X30H(L), FI-X30C2(L) or FI-X30M(A1) (Japan Aviation Electronics Ind. , Ltd.)

Mating LVDS transmitter :THC63LVDM83R or equivalent device

| Pin No. | Symbol | Function | Remark |
|---------|--------|---|--------|
| 1 | VCC | +12V Power Supply | |
| 2 | VCC | +12V Power Supply | |
| 3 | VCC | +12V Power Supply | |
| 4 | VCC | +12V Power Supply | |
| 5 | GND | GND | |
| 6 | GND | GND | |
| 7 | GND | GND | |
| 8 | GND | GND | |
| 9 | GND | GND | |
| 10 | AIN0- | Aport (-)LVDS CH0 differential data input | LVDS |
| 11 | AIN0+ | Aport (+)LVDS CH0 differential data input | LVDS |
| 12 | AIN1- | Aport (-)LVDS CH1 differential data input | LVDS |
| 13 | AIN1+ | Aport (+)LVDS CH1 differential data input | LVDS |
| 14 | AIN2- | Aport (-)LVDS CH2 differential data input | LVDS |
| 15 | AIN2+ | Aport (+)LVDS CH2 differential data input | LVDS |
| 16 | ACK- | Aport LVDS Clock signal(-) | LVDS |
| 17 | ACK+ | Aport LVDS Clock signal(+) | LVDS |
| 18 | AIN3- | Aport (-)LVDS CH3 differential data input | LVDS |
| 19 | AIN3+ | Aport (+)LVDS CH3 differential data input | LVDS |
| 20 | BIN0- | Bport (-)LVDS CH0 differential data input | LVDS |
| 21 | BIN0+ | Bport (+)LVDS CH0 differential data input | LVDS |
| 22 | BIN1- | Bport (-)LVDS CH1 differential data input | LVDS |
| 23 | BIN1+ | Bport (+)LVDS CH1 differential data input | LVDS |
| 24 | BIN2- | Bport (-)LVDS CH2 differential data input | LVDS |
| 25 | BIN2+ | Bport (+)LVDS CH2 differential data input | LVDS |
| 26 | BCK- | Bport LVDS Clock signal(-) | LVDS |
| 27 | BCK+ | Bport LVDS Clock signal(+) | LVDS |
| 28 | BIN3- | Bport (-)LVDS CH3 differential data input | LVDS |
| 29 | BIN3+ | Bport (+)LVDS CH3 differential data input | LVDS |
| 30 | GND | GND | |

[note]GND of a liquid crystal panel drive part has connected with a module chassis.

CN2 (Shown in Fig.1)

Using connector :DF14A-20P-1.25H(59) (HIROSE ELECTRIC Co.,Ltd.)
 Mating connector :DF14-20S-1.25(connector) (HIROSE ELECTRIC Co.,Ltd.)
 :DF14-2628SCFA(Terminal) (HIROSE ELECTRIC Co.,Ltd.)

| Pin No. | Symbol | Function | Remark |
|---------|---------|--|----------------------------------|
| 1 | FRAME1 | Frame frequency setting 1:60Hz 0:50Hz | Pull down: 43k (GND) |
| 2 | O/S SET | O/S operation setting 1:OS ON 0:OS OFF | Pull up: 4.7k (3.3V) |
| 3 | RESERVE | Reserved for Feature | Pull down: 43k (GND) |
| 4 | TEMP3 | Data3 of panel surface temperature | Pull up: 4.7k (3.3V) |
| 5 | TEMP2 | Data2 of panel surface temperature | Pull up: 4.7k (3.3V) |
| 6 | TEMP1 | Data1 of panel surface temperature | Pull up: 4.7k (3.3V) |
| 7 | RESERVE | Not Available | [Note 3] |
| 8 | RESERVE | Not Available | [Note 3] |
| 9 | RESERVE | Not Available | [Note 3] |
| 10 | GND | GND | |
| 11 | R/L | Horizontal shift direction [Note 1] | Pull down: 43k (GND) |
| 12 | U/D | Vertical shift direction [Note 1] | Pull down: 43k (GND) |
| 13 | SELLVDS | Select LVDS data order | Pull up: 8.6k (3.3V) [Note 2] |
| 14 | RESERVE | Not Available | [Note 3] |
| 15 | RESERVE | Not Available | [Note 3] |
| 16 | RESERVE | Not Available | [Note 3] |
| 17 | RESERVE | Not Available | [Note 3] |
| 18 | RESERVE | Not Available | [Note 3] |
| 19 | RESERVE | Not Available | [Note 3] |
| 20 | RESERVE | Not Available | [Note 3] |

*0: Low level voltage (GND) 1: High level voltage(3.3V)

[Note]In case of O/S set setting "1"(O/S_ON), it should be set the Temp1~3 to "1".

According as the surface temperature of the panel, enter the optimum 3 bit signal into pin No.4,5,6.
 Measuring the correlation between detected temperature by the sensor on PWB in users side and actual surface temperature of panel at center, convert the temperature detected by the sensor to the surface temperature of panel to enter the 3 bit temperature data.

| Pin no. | Surface temperature of panel | | | | | | | |
|---------|------------------------------|------|-------|-------|-------|-------|-------|--------------|
| | 0-5 | 5-10 | 10-15 | 15-20 | 20-25 | 25-30 | 30-35 | 35 and above |
| 4 | 0 | 0 | 0 | 0 | 1 | 1 | 1 | 1 |
| 5 | 0 | 0 | 1 | 1 | 0 | 0 | 1 | 1 |
| 6 | 0 | 1 | 0 | 1 | 0 | 1 | 0 | 1 |

*0: Low level voltage (GND) 1: High level voltage(3.3V)

*For overlapping temperatures (such as 5 ,10 ,15 ,20 ,25 , 30 ,35) select the optimum parameter, judging from the actual picture image.

[Note 1] Display reversal function

Normal (Default)

R/L : L (GND) U/D: L (GND)

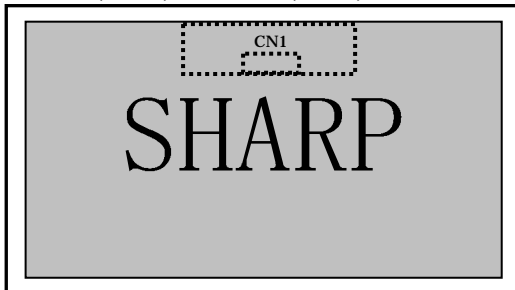

Vertical reverse image

R/L : L (GND) U/D: H (3.3V)

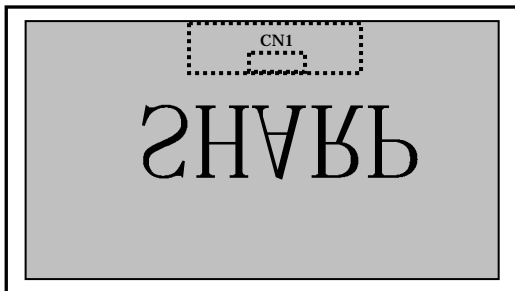

Horizontal reverse image

R/L : H (3.3V) U/D: L (GND)

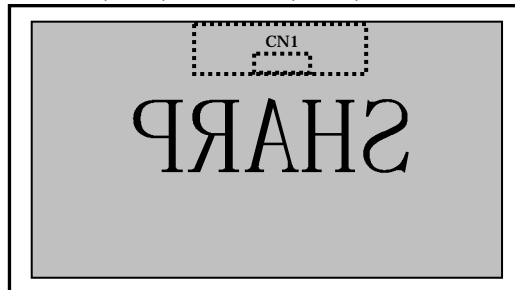

Horizontal and vertical reverse image

R/L : H(3.3V) U/D: H (3.3V)

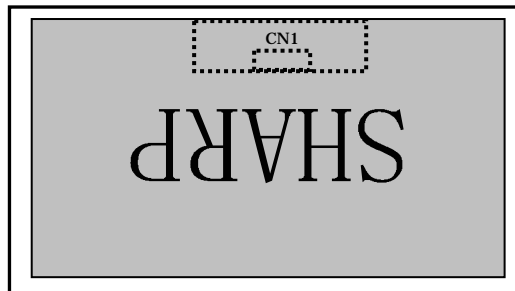

[Note 2] SELLVDS

| Transmitter | | SELLVDS | |
|-------------|------|---------|------------------|
| Pin No | Data | =L(GND) | =H(3.3V) or Open |
| 51 | TA0 | R0(LSB) | R2 |
| 52 | TA1 | R1 | R3 |
| 54 | TA2 | R2 | R4 |
| 55 | TA3 | R3 | R5 |
| 56 | TA4 | R4 | R6 |
| 3 | TA5 | R5 | R7(MSB) |
| 4 | TA6 | G0(LSB) | G2 |
| 6 | TB0 | G1 | G3 |
| 7 | TB1 | G2 | G4 |
| 11 | TB2 | G3 | G5 |
| 12 | TB3 | G4 | G6 |
| 14 | TB4 | G5 | G7(MSB) |
| 15 | TB5 | B0(LSB) | B2 |
| 19 | TB6 | B1 | B3 |
| 20 | TC0 | B2 | B4 |
| 22 | TC1 | B3 | B5 |
| 23 | TC2 | B4 | B6 |
| 24 | TC3 | B5 | B7(MSB) |
| 27 | TC4 | NA | NA |
| 28 | TC5 | NA | NA |
| 30 | TC6 | DE(*) | DE(*) |
| 50 | TD0 | R6 | R0(LSB) |
| 2 | TD1 | R7(MSB) | R1 |
| 8 | TD2 | G6 | G0(LSB) |
| 10 | TD3 | G7(MSB) | G1 |
| 16 | TD4 | B6 | B0(LSB) |
| 18 | TD5 | B7(MSB) | B1 |
| 25 | TD6 | NA | NA |

(*) Since the display position is prescribed by the rise of DE (Display Enable) signal, please do not fix DE signal during operation at "High."

[Note 3] Please do not input anything to this pin.

• Interface block diagram

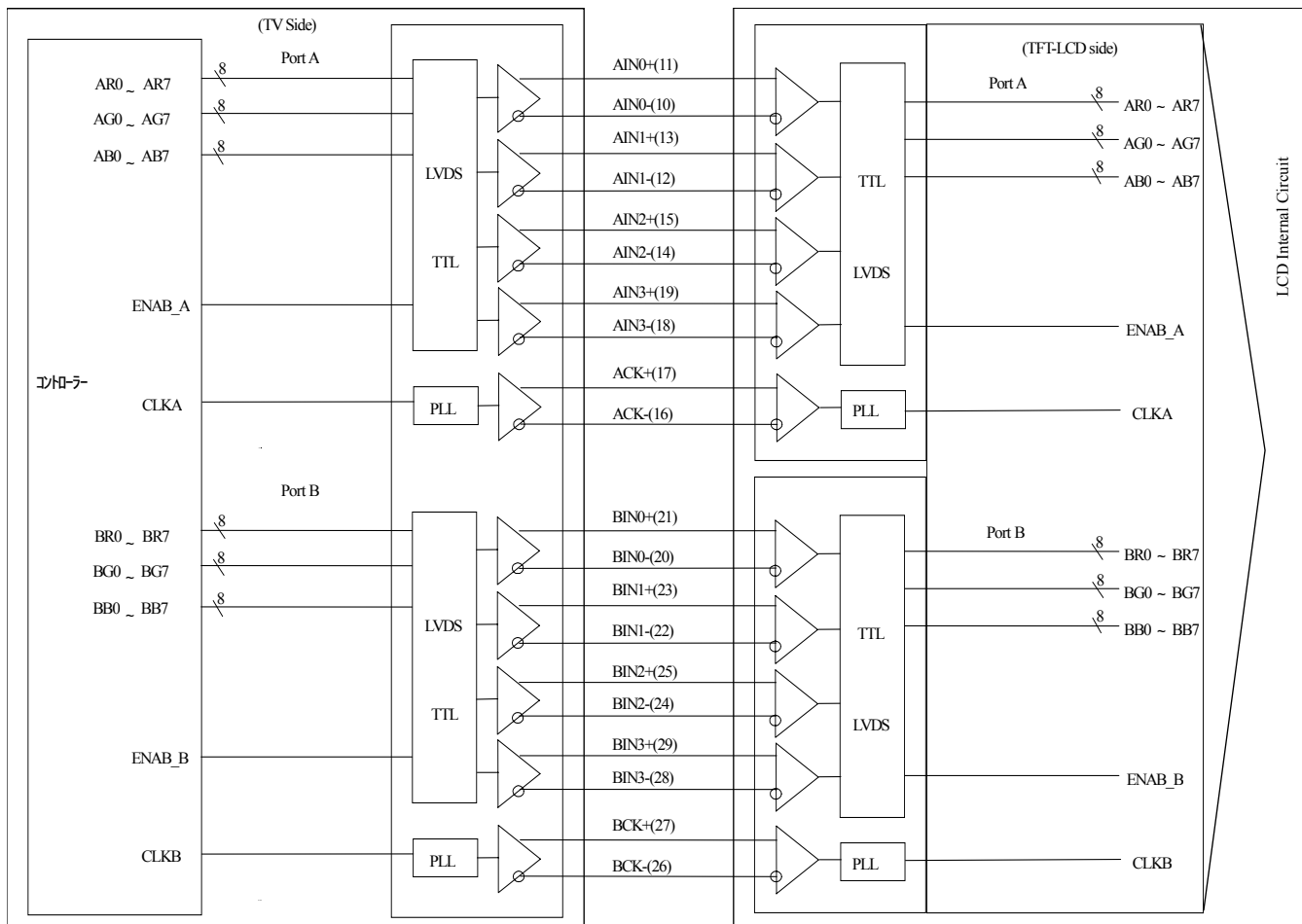

Corresponding Transmitter: THC63LVDM83R (THine) or equivalent device

• Block Diagram (LCD Module)

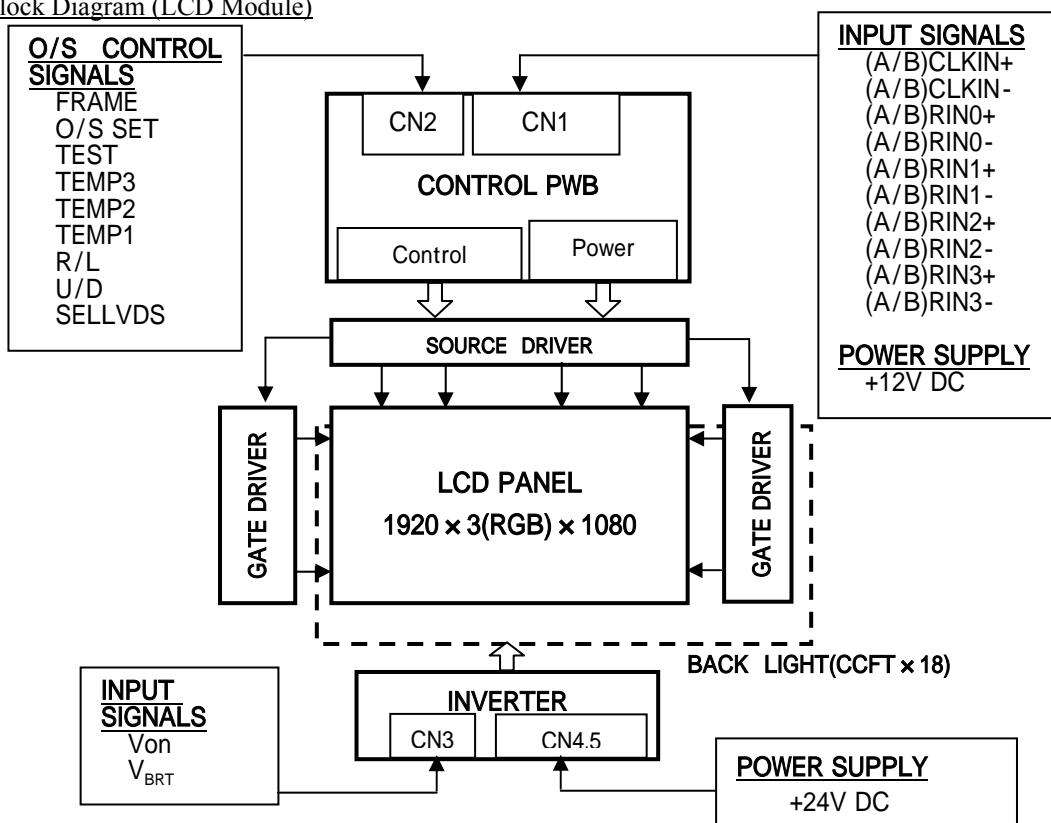

SELLVDS= High (3.3V) or Open

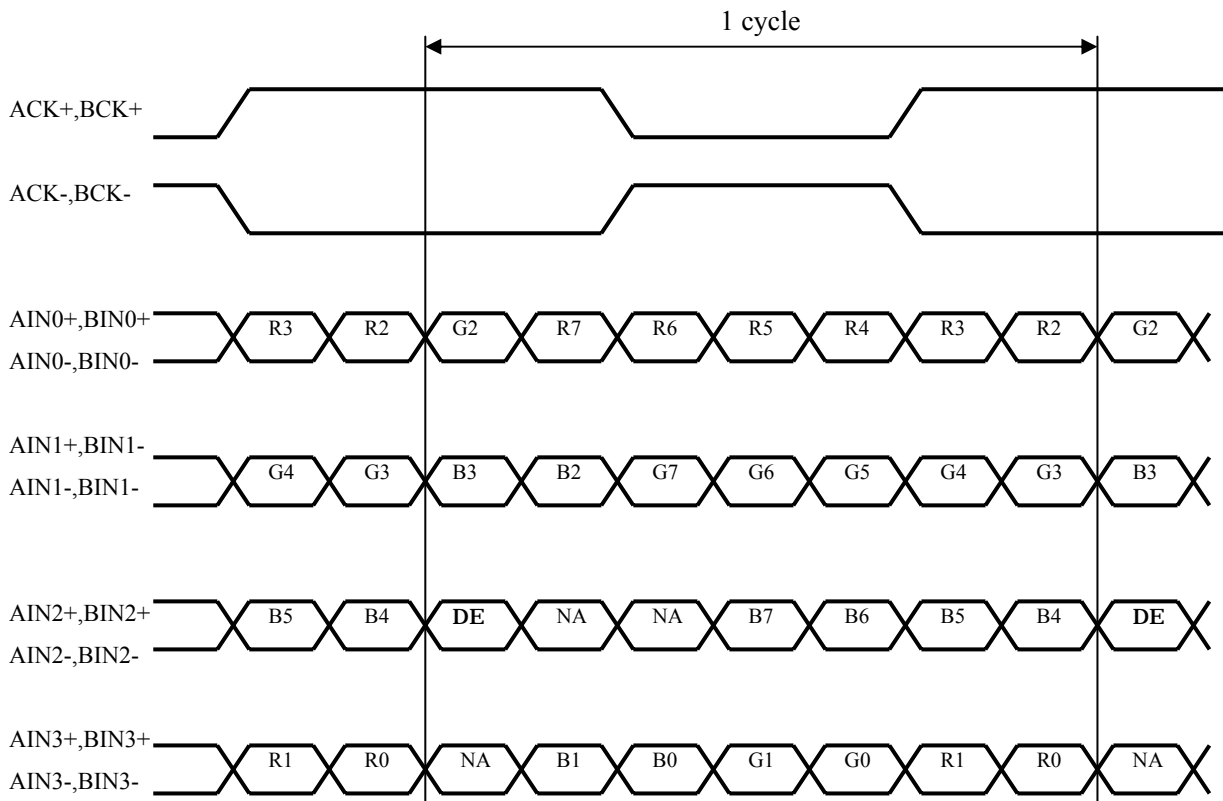

SELLVDS= Low(GND)

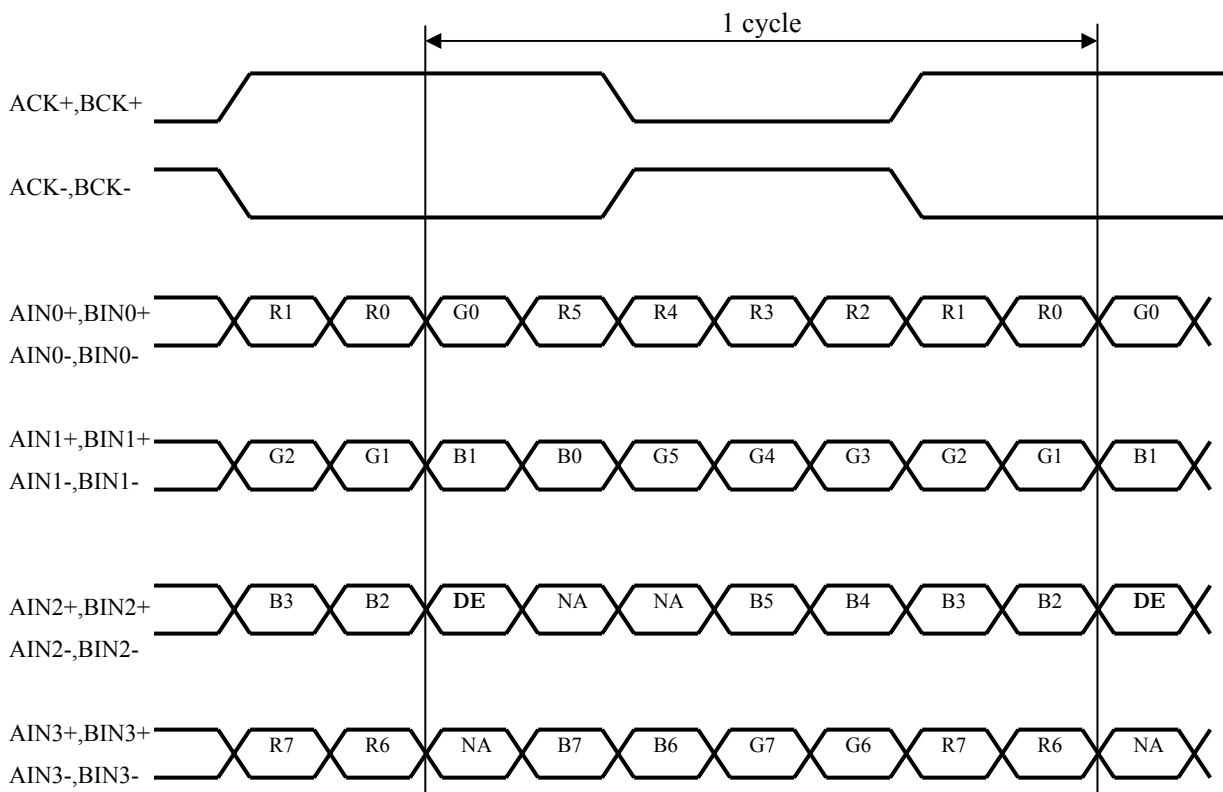

DE: Display Enable

NA: Not Available (Fixed Low)

4-2. Backlight driving

CN3 (Inverter control)

Using connector: B6B-PH-K-S(LF)(JST)

Mating connector: PHR-6 (JST)

| Pin No. | Symbol | Function | Remark |
|---------|------------------|--------------------|----------|
| 1 | V _{ON} | Inverter ON / OFF | [Note 1] |
| 2 | Reserved | Not Available | |
| 3 | Reserved | Not Available | |
| 4 | V _{BRT} | Brightness Control | [Note 2] |
| 5 | Reserved | Not Available | |
| 6 | GND | GND | |

*GND of an inverter board is not connected to GND of a module chassis and a liquid crystal panel drive part.

[Note 1] Inverter ON/OFF

| Input voltage | Function |
|---------------|---------------|
| 5V | Inverter: ON |
| 0V | Inverter: OFF |

[Note 2] Brightness Control

PWM Brightness Control is regulated by analog input voltage (0V to 5V) .

| Input voltage | Function |
|---------------|-------------------------------|
| 5V | Brightness Control : (Dark) |
| 0V | Brightness Control : (Bright) |

CN4, CN5 (Inverter Power input Pin layout)

Using connector: B10B-PH-K-S(LF)(JST)

Mating connector: PHR-10(JST)

| Pin No. | Symbol | Function |
|---------|------------------|----------|
| 1 | V _{INV} | 24V |
| 2 | V _{INV} | 24V |
| 3 | V _{INV} | 24V |
| 4 | V _{INV} | 24V |
| 5 | V _{INV} | 24V |
| 6 | GND | GND |
| 7 | GND | GND |
| 8 | GND | GND |
| 9 | GND | GND |
| 10 | GND | GND |

*GND of an inverter board is not connected to GND of a module chassis and a liquid crystal panel drive part.

4-3. The back light system characteristics

The back light system is direct type with 18 CCFTs (Cold Cathode Fluorescent Tube).

The characteristics of the lamp are shown in the following table.

The value mentioned below is at the case of one CCFT.

| Item | Symbol | Min. | Typ. | Max. | Unit | Remarks |
|-----------|----------------|-------|------|------|------|---------|
| Life time | T _L | 60000 | - | - | Hour | [Note] |

[Note] • Lamp life time is defined as the time when brightness becomes 50% of the original value

in the continuous operation under the condition of Ta=25 and brightness control(V_{BRT}=0V).

• Above value is applicable when the long side of LCD module is placed horizontally (Landscape position).

(Lamp lifetime may vary if LCD module is in portrait position due to the change of mercury density inside the lamp.)

5. Absolute Maximum Ratings

| Parameter | Symbol | Condition | Ratings | Unit | Remark |
|--------------------------------------|-------------------------------------|-----------|------------|------|----------|
| Input voltage (for Control) | V _I | Ta=25 | -0.3 ~ 3.6 | V | [Note 1] |
| 12V supply voltage (for Control) | VCC | Ta=25 | 0 ~ +14 | V | |
| Input voltage (for Inverter) | V _{BRT} V _{ON} | Ta=25 | 0 ~ +6 | V | |
| 24V supply voltage (for Inverter) | V _{INV} | Ta=25 | 0 ~ +29 | V | |
| Storage temperature | Tstg | - | -25 ~ +60 | | [Note 2] |
| Operation temperature (Ambient) | Topa | - | 0 ~ +50 | | |

[Note 1]SELLVDS, R/L, U/D,TEST, Frame1,O/S set, Temp1, Temp2, Temp3

[Note 2]Humidity 95%RH Max.(Ta 40)

Maximum wet-bulb temperature at 39 or less.(Ta>40)

No condensation.

6. Electrical Characteristics

6-1. Control circuit driving

Ta=25

| Parameter | | Symbol | Min. | Typ. | Max. | Unit | Remark |
|--------------------------------------|-----------------|-----------------|------|------|------|-------------------|-------------------------------------|
| +12V supply voltage | Supply voltage | V _{CC} | 11.4 | 12 | 12.6 | V | [Note 1] |
| | Regular current | I _{CC} | - | 0.7 | 1.5 | A | [Note 2] |
| | Rush current | | - | - | 6.5 | A | [Note 7] |
| Permissible input ripple voltage | | V _{RP} | - | - | 100 | mV _{P-P} | V _{CC} = +12.0V |
| Differential input threshold voltage | High | V _{TH} | - | - | 100 | mV | V _{CM} = +1.2V [Note 6] |
| | Low | V _{TL} | -100 | - | - | mV | |
| Input Low voltage | | V _{IL} | - | - | 0.8 | V | [Note 3] |
| Input High voltage | | V _{IH} | 2.0 | - | 3.3 | V | |
| Input leak current (Low) | | I _{IL} | - | - | 400 | μA | V _I = 0V [Note 4] |
| Input leak current (High) | | I _{IH} | - | - | 400 | μA | V _I = 3.3V [Note 5] |
| Terminal resistor | | R _T | - | 100 | - | | Differential input |

[Note] V_{CM}: Common mode voltage of LVDS driver.

[Note 1]

Input voltage sequences

| | |
|--------------------|-------|
| 0 < t ₁ | 20ms |
| 0 < t ₂ | 50ms |
| 0 < t ₃ | 1s |
| 0 < t ₄ | 1s |
| t ₅ | 200ms |
| t ₆ | 0 |
| t ₇ | 300ms |

Dip conditions for supply voltage

- a) 6.5V V_{CC} < 10.8V
 t_d 10ms
 b) V_{CC} < 6.5V

Dip conditions for supply voltage is based on input voltage sequence.

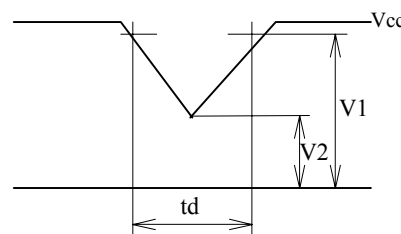
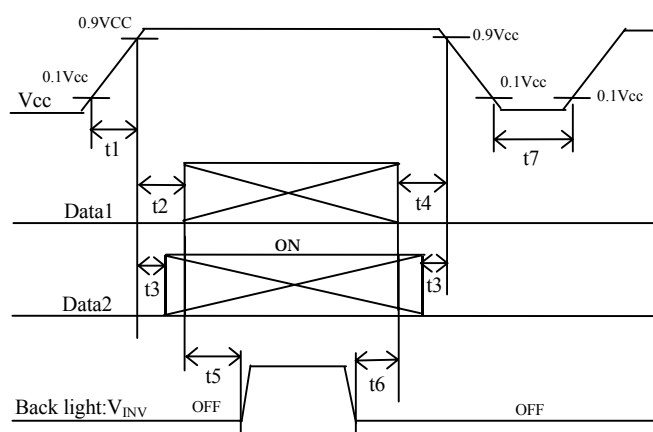

V1:10.8V
 V2:6.5V

Data1: ACK ±, AIN0 ±, AIN1 ±, AIN2 ±, AIN3 ±, BCK ±, BIN0 ±, BIN1 ±, BIN2 ±, BIN3 ±

V_{CM} voltage follows the sequence mentioned above.

Data2: R/L,U/D,SELLVDS,Frame1,O/Sset,Temp1,2,3

Please keep the following order

[On] First, input panel signal, and then turn on the back light

[Off] First, turn off the back light, and then switch off the panel input signal.

Unless you keep the above order, there is a case that all white or unusual screen is displayed instantaneously. However, this phenomenon is caused by variation of the input signal and would not damage LCD module itself.

[Note 2] Maximum current situation: white (RGB GS255)

Typical current situation: 256 gray-bar pattern (Vcc = +12.0V)

The explanation of RGB gray scale is seen in section 8.

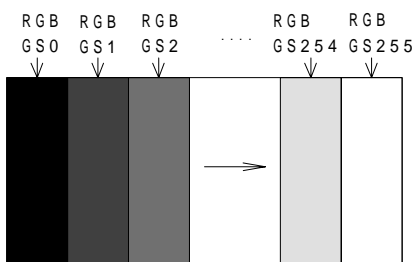

Vcc = 12.0V
 CK = 74.25MHz
 Th = 14.8μs

[Note 3] R/L, U/D, SELLVDS, Frame1,O/S set, Temp1, Temp2, Temp3

[Note 4] SELLVDS

[Note 5] R/L,U/D, Frame1,O/S set, Temp1, Temp2, Temp3

[Note 6] ACK ±, AIN0 ±, AIN1 ±, AIN2 ±, AIN3 ±, BCK ±, BIN0 ±, BIN1 ±, BIN2 ±, BIN3 ±

[Note 7] "Rush current" is measured on a following condition .

Using power supply :

Manufacturer KIKUSUI Electronics Corp.

Type PAN16-10A

Current capacity 10A

LCD driving timing : Typ. Value

Display pattern : White or Max. current pattern

6-2. Inverter driving for back light

The back light system is direct type with 18 CCFTs (Cold Cathode Fluorescent Tube).

Ta=25

| Parameter | Symbol | Min. | Typ. | Max. | Unit | Remark | |
|---|---------------------|------------------|------|------|-------------------|-------------------------|--|
| + 24V | Current dissipation | I _{INV} | - | 5.0 | 5.5 | A | V _{INV} = 24V V _{BRT} = 0V, V _{ON} =5V 【Note 1】 |
| | Supply voltage | V _{INV} | 23.0 | 24.0 | 25.0 | V | |
| Permissible input ripple voltage | V _{RF} | - | - | 200 | mV _{p-p} | V _{INV} = +24V | |
| Input voltage (Low) | V _{ONL} | 0 | - | 1.0 | V | Von impedance=24k | |
| Input voltage (High) | V _{ONH} | 2.3 | 5.0 | 6.0 | V | | |
| Brightness control voltage vs Brightness level (Reference value) | - | 0 | | 5 | V | | |
| | | 100 | | 15 | % | | |

【Note 1】 1)V_{INV}-turn-on condition

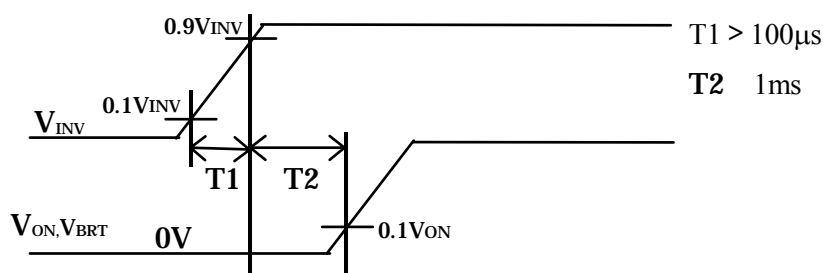

2) V_{INV} -turn-off condition

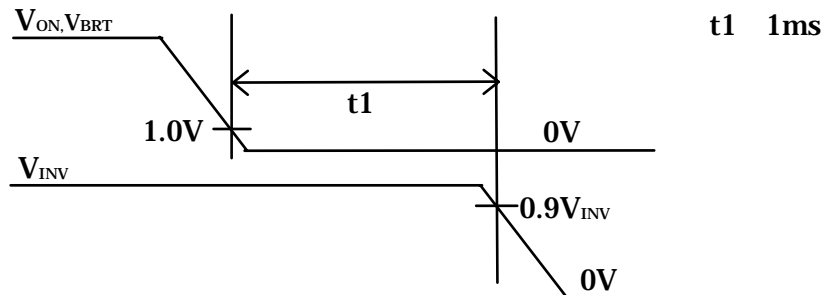

Note : The inverter unit is driving at the following drive frequency.

Lamp driving frequency : 36 ± 5 KHz

Burst dimmer frequency : 275 ± 20 Hz

There is possibility that the display problem of the backlights such as flicker, blinking, etc by the interference of the above inverter driving frequency and the LCD driving frequency will occur.

In setting of a LCD driving frequency, we recommend to set for the no interference with the above frequency to occur.

7. Timing characteristics of input signals

7-1. Timing characteristics

Timing diagrams of input signal are shown in Fig.2.

60Hz-mode

| Parameter | Symbol | Min. | Typ. | Max. | Unit | Remark | |
|------------------------|--------------------------|--------|-------|------|---------|---------|--|
| Clock | Frequency | 55 | 74.25 | 80 | MHz | | |
| Data enable signal | Horizontal period | 984 | 1100 | 1650 | clock | | |
| | | 14.8 | 14.8 | - | μ s | | |
| | Horizontal period (High) | 960 | 960 | 960 | clock | | |
| | Horizontal period (Low) | TH-THd | 1.80 | 1.87 | - | μ s | |
| | Vertical period | TV | 1086 | 1125 | 1350 | line | |
| Vertical period (High) | TVd | 1080 | 1080 | 1080 | line | | |

【Note】 When vertical period is very long, flicker may occur.

Please turn off the module after it shows the black screen.

Please make sure that length of vertical period should become of an integral multiple of horizontal length of period. Otherwise, the screen may not display properly.

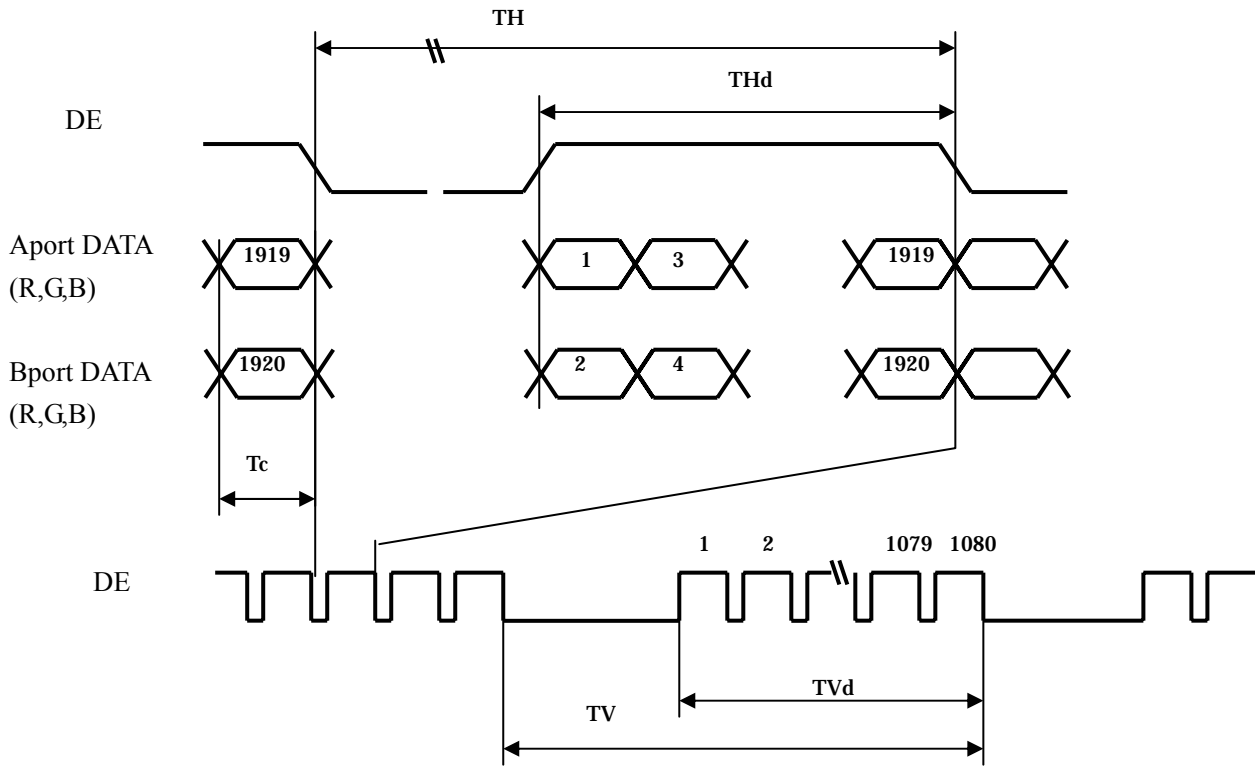
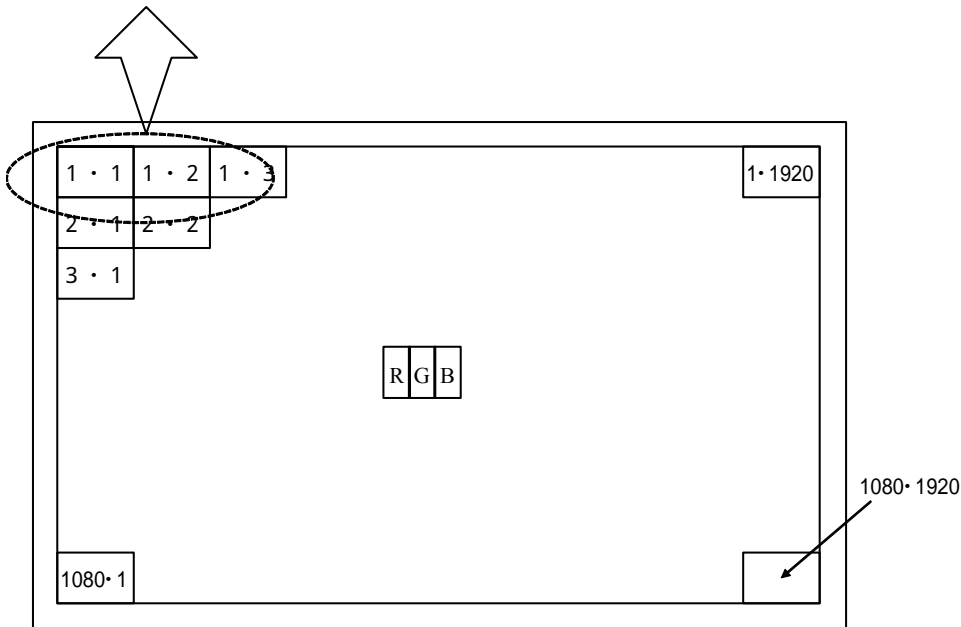

Fig.2 Timing characteristics of input signals

7-2. Input data signal and display position on the screen

| | | | | | |
|--------|--------|----|----|----|----|
| R1 | G1 | B1 | R2 | G2 | B2 |
| (1, 1) | (1, 2) | | | | |



Display position of Dat (V,H)

8. Input Signal, Basic Display Colors and Gray Scale of Each Color

| | Colors & Gray scale | Data signal | | | | | | | | | | | | | | | | | | | | | | | | |
|---------------------|---------------------|-------------|----|----|----|----|----|----|----|----|----|----|----|----|----|----|----|----|----|----|----|----|----|----|----|----|
| | | Gray Scale | R0 | R1 | R2 | R3 | R4 | R5 | R6 | R7 | G0 | G1 | G2 | G3 | G4 | G5 | G6 | G7 | B0 | B1 | B2 | B3 | B4 | B5 | B6 | B7 |
| | | | | | | | | | | | | | | | | | | | | | | | | | | |
| Basic Color | Black | - | 0 | 0 | 0 | 0 | 0 | 0 | 0 | 0 | 0 | 0 | 0 | 0 | 0 | 0 | 0 | 0 | 0 | 0 | 0 | 0 | 0 | 0 | 0 | 0 |
| | Blue | - | 0 | 0 | 0 | 0 | 0 | 0 | 0 | 0 | 0 | 0 | 0 | 0 | 0 | 0 | 0 | 0 | 1 | 1 | 1 | 1 | 1 | 1 | 1 | 1 |
| | Green | - | 0 | 0 | 0 | 0 | 0 | 0 | 0 | 0 | 1 | 1 | 1 | 1 | 1 | 1 | 1 | 1 | 0 | 0 | 0 | 0 | 0 | 0 | 0 | 0 |
| | Cyan | - | 0 | 0 | 0 | 0 | 0 | 0 | 0 | 0 | 1 | 1 | 1 | 1 | 1 | 1 | 1 | 1 | 1 | 1 | 1 | 1 | 1 | 1 | 1 | 1 |
| | Red | - | 1 | 1 | 1 | 1 | 1 | 1 | 1 | 1 | 0 | 0 | 0 | 0 | 0 | 0 | 0 | 0 | 0 | 0 | 0 | 0 | 0 | 0 | 0 | 0 |
| | Magenta | - | 1 | 1 | 1 | 1 | 1 | 1 | 1 | 1 | 0 | 0 | 0 | 0 | 0 | 0 | 0 | 0 | 1 | 1 | 1 | 1 | 1 | 1 | 1 | 1 |
| | Yellow | - | 1 | 1 | 1 | 1 | 1 | 1 | 1 | 1 | 1 | 1 | 1 | 1 | 1 | 1 | 1 | 1 | 0 | 0 | 0 | 0 | 0 | 0 | 0 | 0 |
| | White | - | 1 | 1 | 1 | 1 | 1 | 1 | 1 | 1 | 1 | 1 | 1 | 1 | 1 | 1 | 1 | 1 | 1 | 1 | 1 | 1 | 1 | 1 | 1 | 1 |
| Gray Scale of Red | Black | GS0 | 0 | 0 | 0 | 0 | 0 | 0 | 0 | 0 | 0 | 0 | 0 | 0 | 0 | 0 | 0 | 0 | 0 | 0 | 0 | 0 | 0 | 0 | 0 | 0 |
| | ↑ | GS1 | 1 | 0 | 0 | 0 | 0 | 0 | 0 | 0 | 0 | 0 | 0 | 0 | 0 | 0 | 0 | 0 | 0 | 0 | 0 | 0 | 0 | 0 | 0 | 0 |
| | Darker | GS2 | 0 | 1 | 0 | 0 | 0 | 0 | 0 | 0 | 0 | 0 | 0 | 0 | 0 | 0 | 0 | 0 | 0 | 0 | 0 | 0 | 0 | 0 | 0 | 0 |
| | ↑ | ↓ | | | | | ↓ | | | | | | | ↓ | | | | | | | | ↓ | | | | |
| | ↓ | ↓ | | | | | ↓ | | | | | | | ↓ | | | | | | | | ↓ | | | | |
| | Brighter | GS253 | 1 | 0 | 1 | 1 | 1 | 1 | 1 | 1 | 0 | 0 | 0 | 0 | 0 | 0 | 0 | 0 | 0 | 0 | 0 | 0 | 0 | 0 | 0 | 0 |
| | ↓ | GS254 | 0 | 1 | 1 | 1 | 1 | 1 | 1 | 1 | 0 | 0 | 0 | 0 | 0 | 0 | 0 | 0 | 0 | 0 | 0 | 0 | 0 | 0 | 0 | 0 |
| | Red | GS255 | 1 | 1 | 1 | 1 | 1 | 1 | 1 | 1 | 0 | 0 | 0 | 0 | 0 | 0 | 0 | 0 | 0 | 0 | 0 | 0 | 0 | 0 | 0 | 0 |
| Gray Scale of Green | Black | GS0 | 0 | 0 | 0 | 0 | 0 | 0 | 0 | 0 | 0 | 0 | 0 | 0 | 0 | 0 | 0 | 0 | 0 | 0 | 0 | 0 | 0 | 0 | 0 | 0 |
| | ↑ | GS1 | 0 | 0 | 0 | 0 | 0 | 0 | 0 | 0 | 1 | 0 | 0 | 0 | 0 | 0 | 0 | 0 | 0 | 0 | 0 | 0 | 0 | 0 | 0 | 0 |
| | Darker | GS2 | 0 | 0 | 0 | 0 | 0 | 0 | 0 | 0 | 0 | 1 | 0 | 0 | 0 | 0 | 0 | 0 | 0 | 0 | 0 | 0 | 0 | 0 | 0 | 0 |
| | ↑ | ↓ | | | | | ↓ | | | | | | | ↓ | | | | | | | | ↓ | | | | |
| | ↓ | ↓ | | | | | ↓ | | | | | | | ↓ | | | | | | | | ↓ | | | | |
| | Brighter | GS253 | 0 | 0 | 0 | 0 | 0 | 0 | 0 | 0 | 1 | 0 | 1 | 1 | 1 | 1 | 1 | 1 | 0 | 0 | 0 | 0 | 0 | 0 | 0 | 0 |
| | ↓ | GS254 | 0 | 0 | 0 | 0 | 0 | 0 | 0 | 0 | 0 | 1 | 1 | 1 | 1 | 1 | 1 | 1 | 0 | 0 | 0 | 0 | 0 | 0 | 0 | 0 |
| | Green | GS255 | 0 | 0 | 0 | 0 | 0 | 0 | 0 | 0 | 1 | 1 | 1 | 1 | 1 | 1 | 1 | 1 | 0 | 0 | 0 | 0 | 0 | 0 | 0 | 0 |
| Gray Scale of Blue | Black | GS0 | 0 | 0 | 0 | 0 | 0 | 0 | 0 | 0 | 0 | 0 | 0 | 0 | 0 | 0 | 0 | 0 | 0 | 0 | 0 | 0 | 0 | 0 | 0 | 0 |
| | ↑ | GS1 | 0 | 0 | 0 | 0 | 0 | 0 | 0 | 0 | 0 | 0 | 0 | 0 | 0 | 0 | 0 | 0 | 1 | 0 | 0 | 0 | 0 | 0 | 0 | 0 |
| | Darker | GS2 | 0 | 0 | 0 | 0 | 0 | 0 | 0 | 0 | 0 | 0 | 0 | 0 | 0 | 0 | 0 | 0 | 0 | 1 | 0 | 0 | 0 | 0 | 0 | 0 |
| | ↑ | ↓ | | | | | ↓ | | | | | | | ↓ | | | | | | | | ↓ | | | | |
| | ↓ | ↓ | | | | | ↓ | | | | | | | ↓ | | | | | | | | ↓ | | | | |
| | Brighter | GS253 | 0 | 0 | 0 | 0 | 0 | 0 | 0 | 0 | 0 | 0 | 0 | 0 | 0 | 0 | 0 | 0 | 1 | 0 | 1 | 1 | 1 | 1 | 1 | 1 |
| | ↓ | GS254 | 0 | 0 | 0 | 0 | 0 | 0 | 0 | 0 | 0 | 0 | 0 | 0 | 0 | 0 | 0 | 0 | 0 | 1 | 1 | 1 | 1 | 1 | 1 | 1 |
| | Blue | GS255 | 0 | 0 | 0 | 0 | 0 | 0 | 0 | 0 | 0 | 0 | 0 | 0 | 0 | 0 | 0 | 0 | 1 | 1 | 1 | 1 | 1 | 1 | 1 | 1 |

0 : Low level voltage, 1 : High level voltage.

Each basic color can be displayed in 256 gray scales from 8 bit data signals. According to the combination of total 24 bit data signals, the 16-million-color display can be achieved on the screen.

9. Optical characteristics

Ta=25 , Vcc = 12.0V, V_{INV} = 24.0V ,60Hz-mode

【LQ370D3LZ14】

| Parameter | | Symbol | Condition | Min. | Typ. | Max. | Unit | Remark |
|-----------------------|------------|-----------------|-----------|-------|---------|-------|-------------------|---------------------------------------|
| Viewing angle range | Horizontal | 21 22 | CR 10 | 70 | 88 A | - | Deg. | [Note1,4] |
| | Vertical | 11 12 | | 70 | 88 A | - | Deg. | |
| Contrast ratio | | CRn | =0 deg. | 1000 | 1200 | - | | [Note2,4] V _{BRT} =0V |
| Response time(1) | | r1 d1 | | - | 6 | - | mS | [Note3-1,4,5] V _{BRT} =0V |
| Response time(2) | | r2 d2 | | - | 12 | 20 | mS | [Note3-2,4,5] V _{BRT} =0V |
| Chromaticity of white | | x | | 0.242 | 0.272 | 0.302 | - | [Note 4] V _{BRT} =0V |
| | | y | | 0.247 | 0.277 | 0.307 | - | |
| Chromaticity of red | | x | | 0.610 | 0.640 | 0.670 | - | |
| | | y | | 0.300 | 0.330 | 0.360 | - | |
| Chromaticity of green | | x | | 0.250 | 0.280 | 0.310 | - | |
| | | y | | 0.570 | 0.600 | 0.630 | - | |
| Chromaticity of blue | | x | | 0.120 | 0.150 | 0.180 | - | |
| | | y | | 0.030 | 0.060 | 0.090 | - | |
| Luminance of white | | Y _{LI} | | 440 | 550 | | cd/m ² | [Note 4] |
| Luminance uniformity | | w | | - | - | 1.25 | | [Note 6] |

【LQ370D3LZ14B】 B

| Parameter | | Symbol | Condition | Min. | Typ. | Max. | Unit | Remark |
|-----------------------|------------|-----------------|-----------|--------------|--------------|--------------|-------------------|---------------------------------------|
| Viewing angle range | Horizontal | 21 22 | CR 10 | 70 | 88 | - | Deg. | [Note1,4] |
| | Vertical | 11 12 | | 70 | 88 | - | Deg. | |
| Contrast ratio | | CRn | =0 deg. | 1000 | 1200 | - | | [Note2,4] V _{BRT} =0V |
| Response time(1) | | r1 d1 | | - | 6 | - | mS | [Note3-1,4,5] V _{BRT} =0V |
| Response time(2) | | r2 d2 | | - | 12 | 20 | mS | [Note3-2,4,5] V _{BRT} =0V |
| Chromaticity of white | | x | | 0.248 | 0.278 | 0.308 | - | [Note 4] V _{BRT} =0V |
| | | y | | 0.255 | 0.285 | 0.315 | - | |
| Chromaticity of red | | x | | 0.610 | 0.640 | 0.670 | - | |
| | | y | | 0.300 | 0.330 | 0.360 | - | |
| Chromaticity of green | | x | | 0.250 | 0.280 | 0.310 | - | |
| | | y | | 0.570 | 0.600 | 0.630 | - | |
| Chromaticity of blue | | x | | 0.120 | 0.150 | 0.180 | - | |
| | | y | | 0.030 | 0.060 | 0.090 | - | |
| Luminance of white | | Y _{LI} | | 440 | 550 | | cd/m ² | [Note 4] |
| Luminance uniformity | | w | | - | - | 1.25 | | [Note 6] |

Measurement condition: Set the value of V_{BRT} to maximum luminance of white.

*The measurement shall be executed 60 minutes after lighting at rating.

【Note】 The optical characteristics are measured using the following equipment.

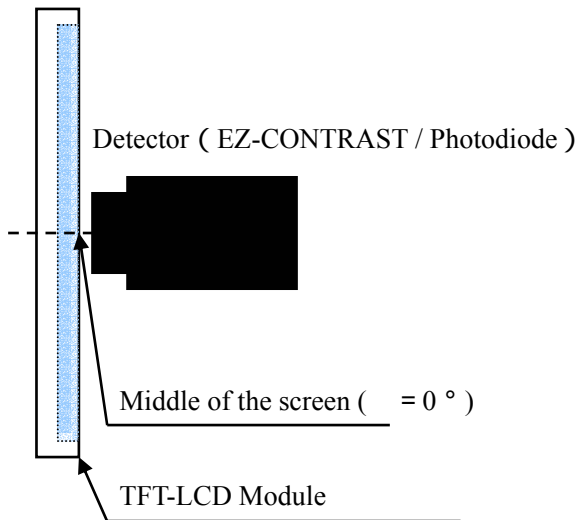

Fig.4-1 Measurement of viewing angle range and Response time.
(Viewing angle range: EZ-CONTRAST,
Response time: Photodiode)

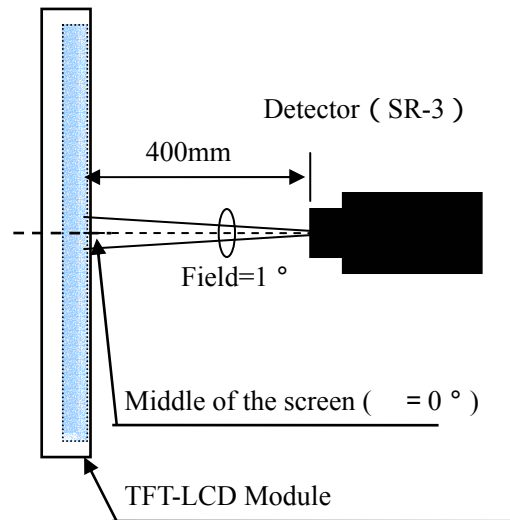
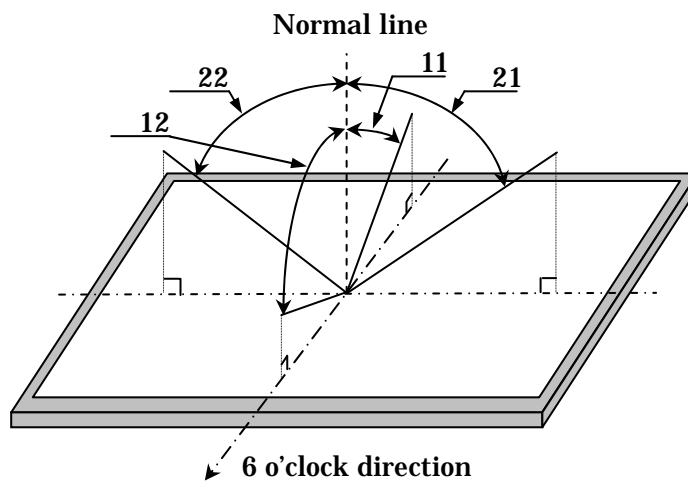

Fig.4-2 Measurement of Contrast, Luminance, Chromaticity and Response time.

[Note 1]Definitions of viewing angle range :



[Note 2]Definition of contrast ratio :

The contrast ratio is defined as the following.

$$\text{Contrast Ratio} = \frac{\text{Luminance (brightness) with all pixels white}}{\text{Luminance (brightness) with all pixels black}}$$

[Note 3]Definition of response time

3-1. Response time (1)

The response time ($\tau d1$ and $\tau r1$) is defined as the following figure and shall be measured by switching the input signal for “any level of gray (GS0, GS32, GS64, GS96, GS128, GS160, GS192, GS224 and GS255)” and “any level of gray (GS0, GS32, GS64, GS96, GS128, GS160, GS192, GS224 and GS255)”.

| | GS0 | GS32 | GS64 | GS96 | GS128 | GS160 | GS192 | GS224 | GS255 |
|-------|----------|-----------|-----------|-----------|------------|------------|------------|------------|------------|
| GS0 | | tr:0-32 | tr:0-64 | tr:0-96 | tr:0-128 | tr:0-160 | tr:0-192 | tr:0-224 | tr:0-255 |
| GS32 | td:32-0 | | tr:32-64 | tr:32-96 | tr:32-128 | tr:32-160 | tr:32-192 | tr:32-224 | tr:32-255 |
| GS64 | td:64-0 | td:64-32 | | tr:64-96 | tr:64-128 | tr:64-160 | tr:64-192 | tr:64-224 | tr:64-255 |
| GS96 | td:96-0 | td:96-32 | td:96-64 | | tr:96-128 | tr:96-160 | tr:96-192 | tr:96-224 | tr:96-225 |
| GS128 | td:128-0 | td:128-32 | td:128-64 | td:128-96 | | tr:128-160 | tr:128-192 | tr:128-224 | tr:128-255 |
| GS160 | td:160-0 | td:160-32 | td:160-64 | td:160-96 | td:160-128 | | tr:160-192 | tr:160-224 | tr:160-255 |
| GS192 | td:192-0 | td:192-32 | td:192-64 | td:192-96 | td:192-128 | td:192-160 | | tr:192-224 | tr:192-255 |
| GS224 | td:224-0 | td:224-32 | td:224-64 | td:224-96 | td:224-128 | td:224-160 | td:224-192 | | tr:224-255 |
| GS255 | td:255-0 | td:255-32 | td:255-64 | td:255-96 | td:255-128 | td:255-160 | td:255-192 | td:255-224 | |

t*:x-y...response time from level of gray(x) to level of gray(y)

$$\tau r1 = \Sigma(tr:x-y)/36, \tau d1 = \Sigma(td:x-y)/36$$

3-2. Response time (2)

The response time is defined as the following figure and shall be measured by switching the input signal for “any level of gray (bright)” and “any level of gray (dark)”.

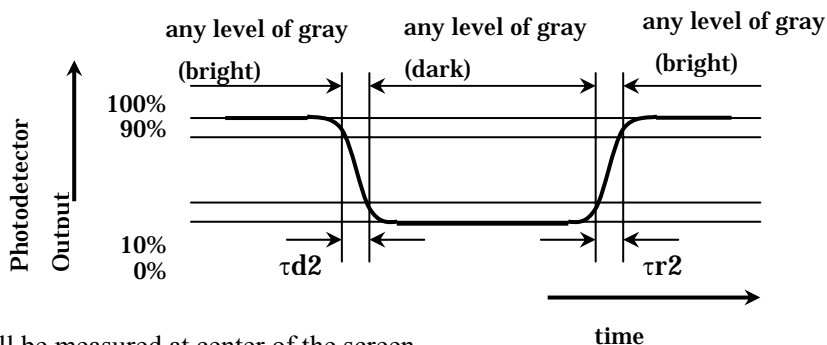

[Note 4]This shall be measured at center of the screen.

[Note 5] “Response time” is the value when O/S driving is used at typical input time value .

[Note 6]Definition of white uniformity ;

White uniformity is defined as the following with five measurements. (A ~ E)

$$w = \frac{\text{Maximum luminance of five points (brightness)}}{\text{Minimum luminance of five points (brightness)}}$$

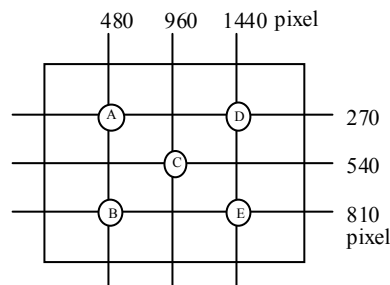

10. Handling Precautions of the module

- a) Be sure to turn off the power supply when inserting or disconnecting the cable.
- b) This product is using the parts (inverter, CCFT etc), which generate the high voltage. Therefore, during operating, please don't touch these parts.
- c) Brightness control voltage is switched for "ON" and "OFF", as shown in Fig.4. Voltage difference generated by this switching, V_{INV} , may affect a sound output, etc. when the power supply is shared between the inverter and its surrounding circuit. So, separate the power supply of the inverter circuit with the one of its surrounding circuit.

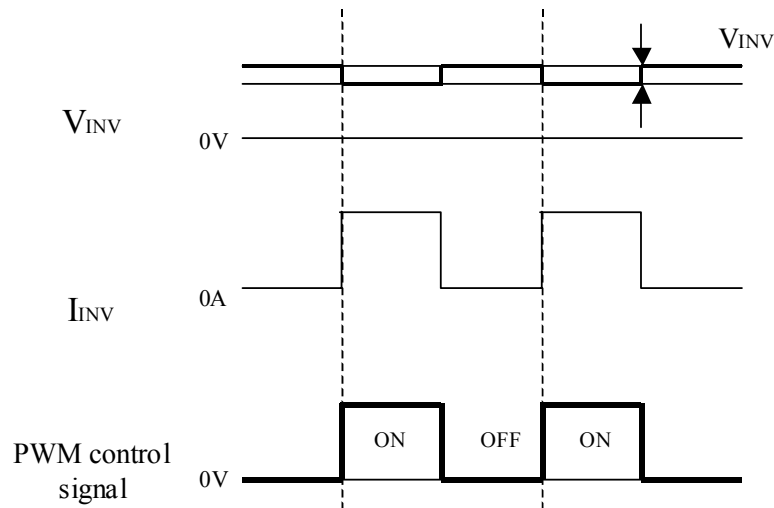

Fig.4 Brightness control voltage.

*Since inverter board's GND is not connected to the frame of the LCD module, please connect it with the Customer's GND of inverter power supply.

- d) Be sure to design the cabinet so that the module can be installed without any extra stress such as warp or twist.
- e) Since the front polarizer is easily damaged, pay attention not to scratch it.
- f) Since long contact with water may cause discoloration or spots, wipe off water drop immediately.
- g) When the panel surface is soiled, wipe it with absorbent cotton or other soft cloth.
- h) Since the panel is made of glass, it may break or crack if dropped or bumped on hard surface. Handle with care.
- i) Since CMOS LSI is used in this module, take care of static electricity and take the human earth into consideration when handling.
- j) The module has some printed circuit boards (PCBs) on the back side, take care to keep them from any stress or pressure when handling or installing the module; otherwise some of electronic parts on the PCBs may be damaged.
- k) Observe all other precautionary requirements in handling components.
- l) When some pressure is added onto the module from rear side constantly, it causes display non-uniformity issue, functional defect, etc.. So, please avoid such design.
- m) When giving a touch to the panel at power on supply, it may cause some kinds of degradation. In that case, once turn off the power supply, and turn on after several seconds again, and that is disappear.
- n) When handling LCD modules and assembling them into cabinets, please be noted that long-term storage in the environment of oxidization or deoxidization gas and the use of such materials as reagent, solvent, adhesive, resin, etc. which generate these gasses, may cause corrosion and discoloration of the LCD modules.

12. Packing form

- a) Piling number of cartons: 3 maximum
- b) Packing quantity in one carton: 5 pcs.
- c) Carton size: 980 (W) × 460 (D) × 721 (H)
- d) Total mass of one carton filled with full modules: 50 kg(Max)

13. Reliability test item

| No. | Test item | Condition |
|-----|---|---|
| 1 | High temperature storage test | Ta=60 240h |
| 2 | Low temperature storage test | Ta=-25 240h |
| 3 | High temperature and high humidity operation test | Ta=40 ; 95%RH 240h (No condensation) |
| 4 | High temperature operation test | Ta=50 240h |
| 5 | Low temperature operation test | Ta=0 240h |
| 6 | Vibration test (non-operation) | Frequency: 10~57Hz/Vibration width (one side): 0.075mm : 58~500Hz/Acceleration: 9.8 m/s ² Sweep time: 11 minutes Test period: 3 hours (1h for each direction of X, Y, Z) |
| 7 | Shock test (non-operation) | Maximum acceleration: 490m/s ² Pulse width: 11ms, sinusoidal half wave Direction: +/-X, +/-Y, +/-Z, once for each direction. |
| 8 | ESD | * At the following conditions, it is a thing without incorrect operation and destruction. (1)Non-operation: Contact electric discharge ± 10kV Non-contact electric discharge ± 20kV (2)Operation Contact electric discharge ± 8kV Non-contact electric discharge ± 15kV Conditions: 150pF、330ohm |

【Result evaluation criteria】

Under the display quality test condition with normal operation state, there shall be no change, which may affect practical display function.

14. Others

1) Lot No. Label ; A

The label that displays SHARP, product model (LQ370D3LZ14), a product number and “MADE IN JAPAN” is stuck on the back of the module.

【LQ370D3LZ14】

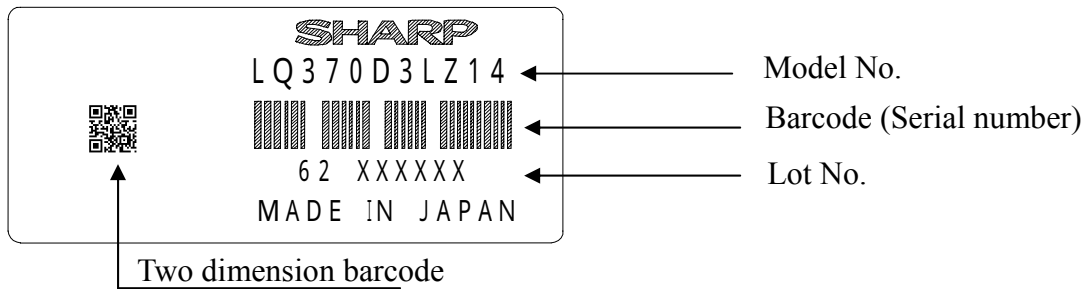

【LQ370D3LZ14B】 B

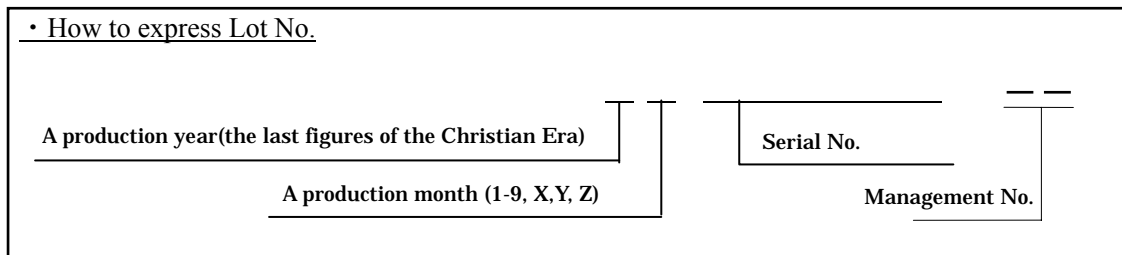
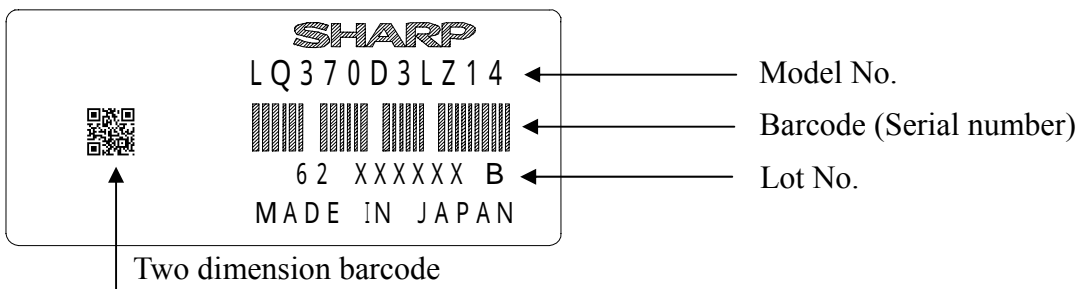

2) Packing Label

【LQ370D3LZ14】

社内品番(4 S)LQ370D3LZ14 ()

Bar code

LotNO. (1T) 2006. *.** ()

Bar code

Quantity (O) 5 pcs ()

Bar code

ユーザ品番
シャープ物流用ラベルです。

【LQ370D3LZ14B】 B

社内品番(4 S)LQ370D3LZ14B ()

Bar code

LotNO. (1T) 2006. *.** ()

Bar code

Quantity (O) 5 pcs ()

Bar code

ユーザ品番
シャープ物流用ラベルです。

Management No.

Lot No. (Date)

Quantity

3) Adjusting volume have been set optimally before shipment, so do not change any adjusted value.

If adjusted value is changed, the specification may not be satisfied.

4) Disassembling the module can cause permanent damage and should be strictly avoided.

5) Please be careful since image retention may occur when a fixed pattern is displayed for a long time.

6) The chemical compound, which causes the destruction of ozone layer, is not being used.

7) Label of material information

The optical part material has been described to the module as shown in the figure below.

| MATERIAL INFORMATION | |
|----------------------|--|
| OPTICAL FILM | :> <u>PC</u> , <u>PEST</u> , <u>AKUR-X</u> , <u>PC</u> < |
| LENS FILM | :> <u>PET</u> , <u>AK-X</u> < |
| DIFFUSER SHEET | :> <u>PMMA-X</u> , <u>PET</u> < |
| DIFFUSER BOARD | :> <u>SMMA</u> , <u>PS</u> < |
| REFLECTOR | :> <u>PAK-QD</u> , <u>PET+PMP</u> < |

8) Cold cathode fluorescent lamp in LCD PANEL contains a small amount of mercury. Please follow local ordinances or regulations for disposal. The below figure shows the label.

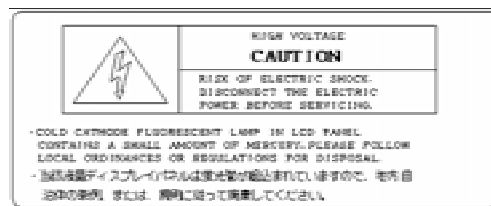

9) When any question or issue occurs, it shall be solved by mutual discussion.

15. Carton storage condition

Temperature 0 to 40

Humidity 95%RH or less

Reference condition : 20 to 35 , 85%RH or less (summer)

: 5 to 15 , 85%RH or less (winter)

• the total storage time (40 , 95%RH) : 240H or less

Sunlight Be sure to shelter a product from the direct sunlight.

Atmosphere Harmful gas, such as acid and alkali which bites electronic components and/or wires must not be detected.

Notes Be sure to put cartons on palette or base, don't put it on floor, and store them with removing from wall

Please take care of ventilation in storehouse and around cartons, and control changing temperature is within limits of natural environment

Storage life 1 year

LQ370D3LZ14 Packing form

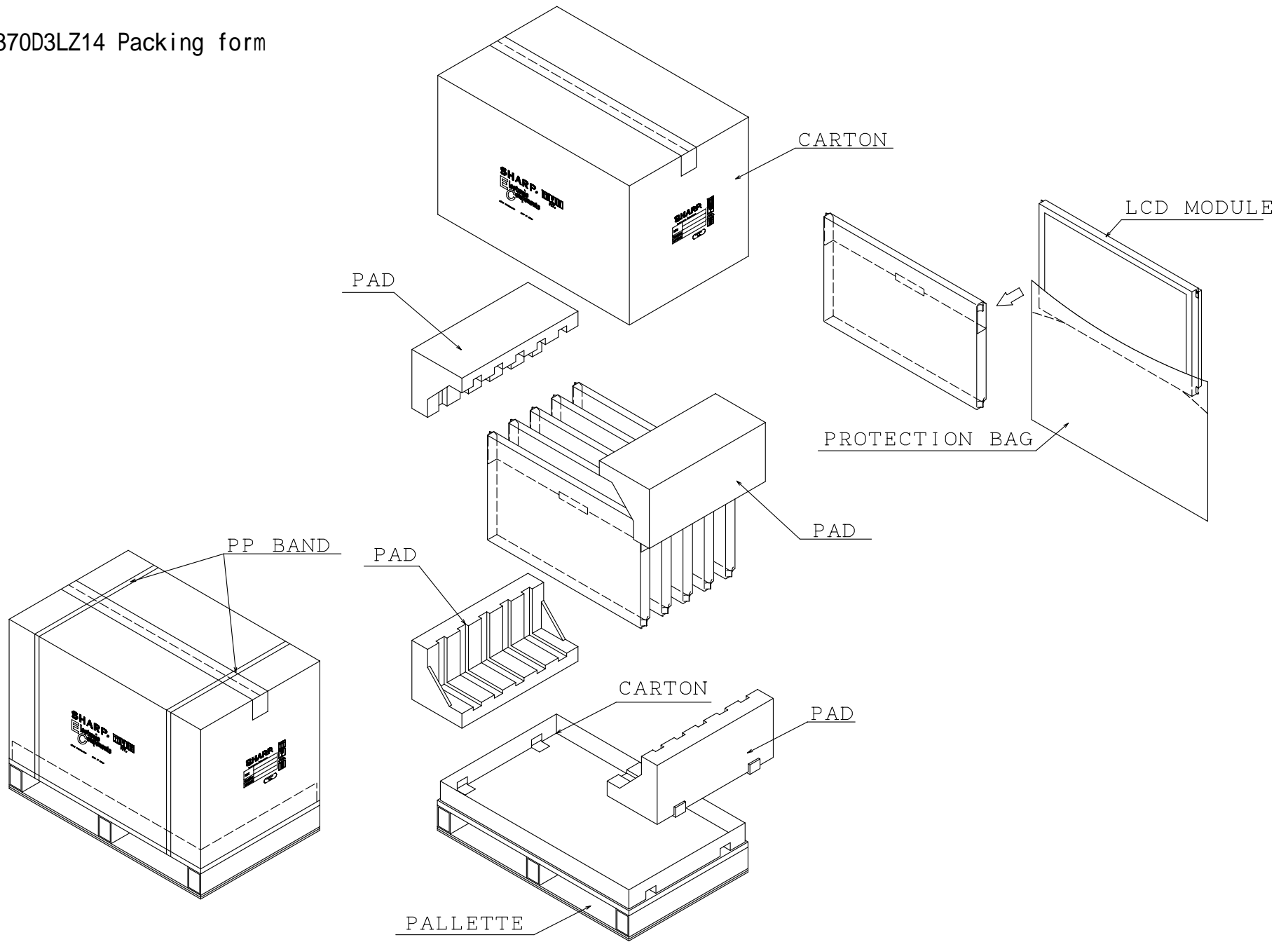

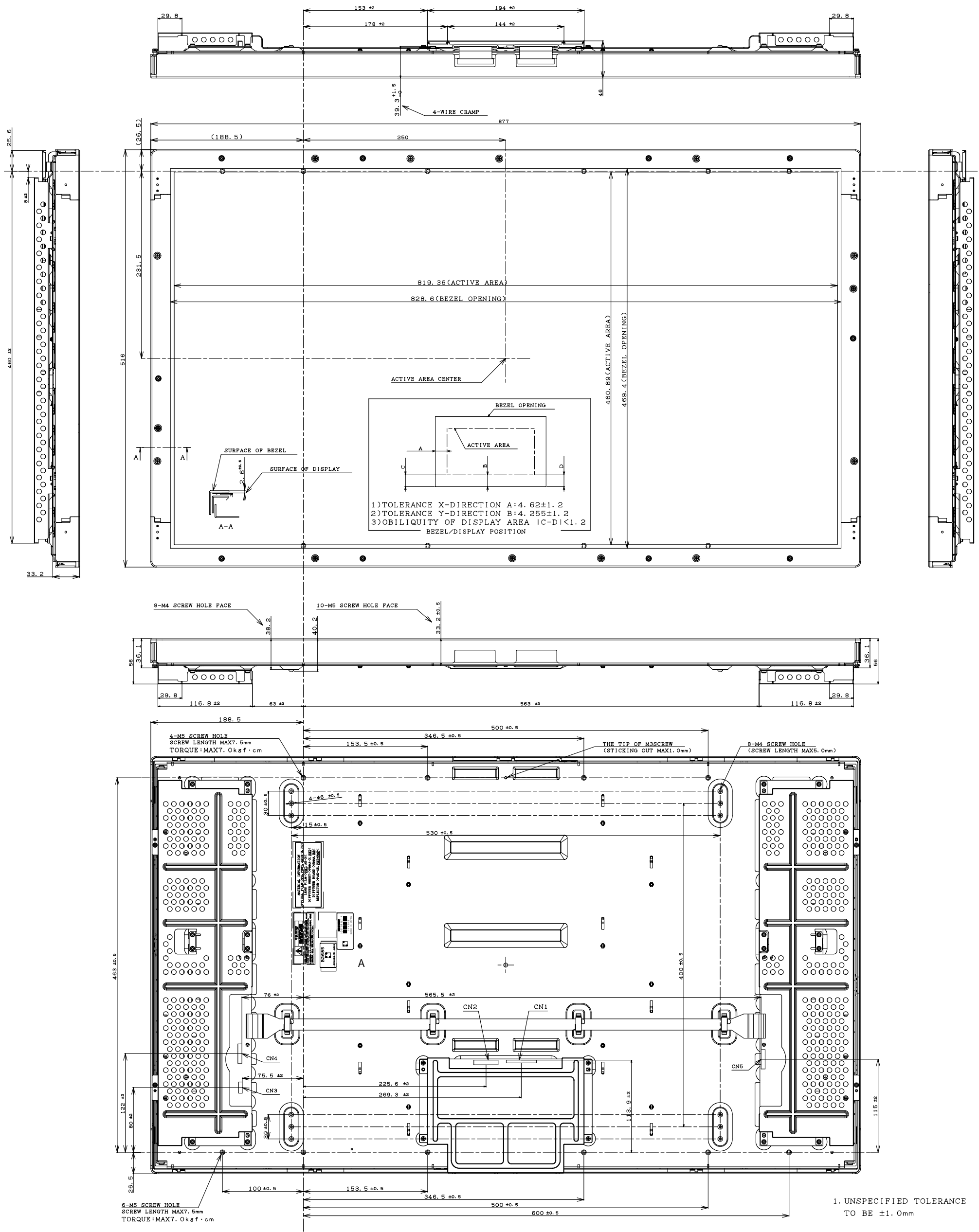

Fig.1 LQ370D3LZ14 Outline dimensions