

LQ64D343

Color TFT LCD Module

(Model Number: LQ64D343)

Specifications

Spec No.: LCY-00030B

Dated: May 31. 2002

PREPARED BY : DATE

m. mayumi. Aug. 8. 2000

APPROVED BY : DATE

C. Kondo. Aug 8. 2000

SHARP

SHARP CORPORATION

SPECIFICATION

SPEC No. LCY-00030A

FILE No.

ISSUE : Aug. 2, 2000

PAGE : 19 pages

DEVELOPMENT ENGINEERING DEPT. II

TFT DIVISION. I

TFT LIQUID CRYSTAL DISPLAY GROUP

DEVICE SPECIFICATION FOR

TFT-LCD Module

MODEL No.

LQ64D343

CUSTOMER'S APPROVAL

DATE _____

BY _____

PRESENTED

BY *S. yasuda* _____

S. YASUDA

DIVISION DUPTY GENERAL MANAGER

TFT DIVISION. I

TFT LIQUID CRYSTAL DISPLAY GROUP

SHARP CORPORATION

NOTICE

This publication is the proprietary of SHARP and is copyrighted, with all rights reserved. Under the copyright laws, no part of this publication may be reproduced or transmitted in any form or by any means, electronic or mechanical for any purpose, in whole or in part, without the express written permission of SHARP. Express written permission is also required before any use of this publication may be made by a third party.

The application circuit examples in this publication are provided to explain the representative applications of SHARP's devices and are not intended to guarantee any circuit design or permit any industrial property right or other rights to be executed. SHARP takes no responsibility for any problems related to any industrial property right or a third party resulting from the use of SHARP's devices, except for those resulting directly from device manufacturing processes.

In the absence of confirmation by device specification sheets, SHARP takes no responsibility for any defects that occur in equipment using any of SHARP's devices, shown in catalogs, data books, etc. Contact SHARP in order to obtain the latest device specification sheets before using any SHARP's device.

SHARP reserves the right to make changes in the specifications, characteristics, data, materials, structures and other contents described herein at any time without notice in order to improve design or reliability. Contact SHARP in order to obtain the latest specification sheets before using any SHARP's device. Manufacturing locations are also subject to change without notice.

Observe the following points when using any device in this publication. SHARP takes no responsibility for damage caused by improper use of the devices.

The devices in this publication are designed for use in general electronic equipment designs, such as:

- Automotive auxiliary information display
- Automotive audio visual equipment

The appropriate design measures should be taken to ensure reliability and safety when SHARP's devices are used for equipment such as:

- Transportation control and safety equipment(i.e., aircraft, trains, automobiles, etc.)
- Traffic signals • Gas leakage sensor breakers
- Alarm equipment • Various safety devices etc.

SHARP's devices shall not be used for equipment that requires extremely high level of reliability, such as:

- Military and space applications • Nuclear power control equipment
- Medical equipment for life support

Contact a SHARP representative, in advance, when intending to use SHARP's devices for any "specific" applications other than those recommended by SHARP.

Contact and consult with a SHARP representative if there are any questions about the contents of this publication.

1. Application

This specification applies to color TFT-LCD module, LQ64D343.

These specification sheets are the proprietary product of SHARP CORPORATION ("SHARP") and Include materials protected under copyright of SHARP.

Do not reproduce or cause any third party to reproduce them in any form or by any means, electronic or mechanical, for any purpose in whole or in part, without the express written permission of SHARP.

The device listed in these specification sheets was designed and manufactured for use in general electronic equipment.

In case of using the device for applications such as control and safety equipment for transportation(aircraft, trains, automobiles, etc.), rescue and security equipment and various safety related equipment which require higher reliability and safety, take into consideration that appropriate measures such as fail-safe functions and redundant system design should be taken.

Do not use the device for equipment that requires an extreme level of reliability, such as aerospace applications, telecommunication equipment(trunk lines), nuclear power control equipment and medical or other equipment for life support.

SHARP assumes no responsibility for any damage resulting from the use of the device which does not comply with the instructions and the precautions specified in these specification sheets.

Contact and consult with a SHARP sales representative for any questions about this device.

2. Overview

This module is a color active matrix LCD module incorporating amorphous silicon TFT (Thin Film Transistor).

It is composed of a color TFT-LCD panel, driver ICs, control circuit and power supply circuit and a backlight unit. Graphics and texts can be displayed on a $640 \times 3 \times 480$ dots panel with 262,144 colors by supplying 18 bit data signal (6bit/color), four timing signals, +5V DC supply voltage for TFT-LCD panel driving and supply voltage for backlight.

The TFT-LCD panel used for this module is a low-reflection and higher-color-saturation type.

Therefore, this module is also suitable for the multimedia use.

Viewing angle is 6 o'clock direction.

This module is the type of wide viewing angle and high brightness(300cd/m²).

Backlight-driving DC/AC inverter is not built in this module.

3. Mechanical Specifications

Parameter	Specifications	Unit
Display size	16 (6.4") Diagonal	cm
Active area	130.6(H)×97.0(V)	mm
Pixel format	640(H)×480(V)	pixel
	(1 pixel=R+G+B dots)	—
Pixel pitch	0.204(H)×0.202(V)	mm
Pixel configuration	R,G,B vertical stripe	—
Display mode	Normally white	—
Unit outline dimensions *1	175.0(W)×126.5(H)×12.0(D)	mm
Mass	280 (MAX.)	g
Surface treatment	Anti-glare and hard coating 3H Haze value = 28%	—

*1.Note: excluding backlight cables.

Outline dimensions is shown in Fig.1

4. Input Terminals

4-1. TFT-LCD Panel Driving

CN1 Used connector:DF9BA-31P-1V (Hirose Electric Co., Ltd.)

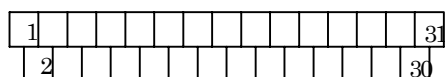

CN1 pin arrangement from module surface
(Transparent view)

Corresponding connector: DF9 -31S-1V (")
DF9A-31S-1V (")
DF9B-31S-1V (")
DF9M-31S-1V (")

Pin No.	Symbol	Function	Remark
1	GND	—	—
2	CK	Clock signal for sampling each data signal	—
3	Hsync	Horizontal synchronous signal	【Note1】
4	Vsync	Vertical synchronous signal	【Note1】
5	GND	—	—
6	R0	RED data signal(LSB)	—
7	R1	RED data signal	—
8	R2	RED data signal	—
9	R3	RED data signal	—
10	R4	RED data signal	—
11	R5	RED data signal(MSB)	—
12	GND	—	—
13	G0	GREEN data signal(LSB)	—
14	G1	GREEN data signal	—
15	G2	GREEN data signal	—
16	G3	GREEN data signal	—
17	G4	GREEN data signal	—
18	G5	GREEN data signal(MSB)	—
19	GND	—	—
20	B0	BLUE data signal(LSB)	—
21	B1	BLUE data signal	—
22	B2	BLUE data signal	—
23	B3	BLUE data signal	—
24	B4	BLUE data signal	—
25	B5	BLUE data signal(MSB)	—
26	GND	—	—
27	ENAB	Signal to settle the horizontal display position	【Note2】
28	Vcc	+5.0V power supply	—
29	Vcc	+5.0V power supply	—
30	R/L	Horizontal display mode select signal	【Note3】
31	U/D	Vertical display mode select signal	【Note4】

※The shielding case is not connected with GND

【Note1】480 line, 400 line or 350 line mode
is selected by the polarity

combination

Mode	480 lines	400 lines	350 lines
Hsync	Negative	Negative	Positive
Vsync	Negative	Positive	Negative

【Note2】The horizontal display start timing is settled in accordance with a rising timing of ENAB signal. In case ENAB is fixed "Low", the horizontal start timing is determined as described in 7-2. Don't keep ENAB "High" during operation.

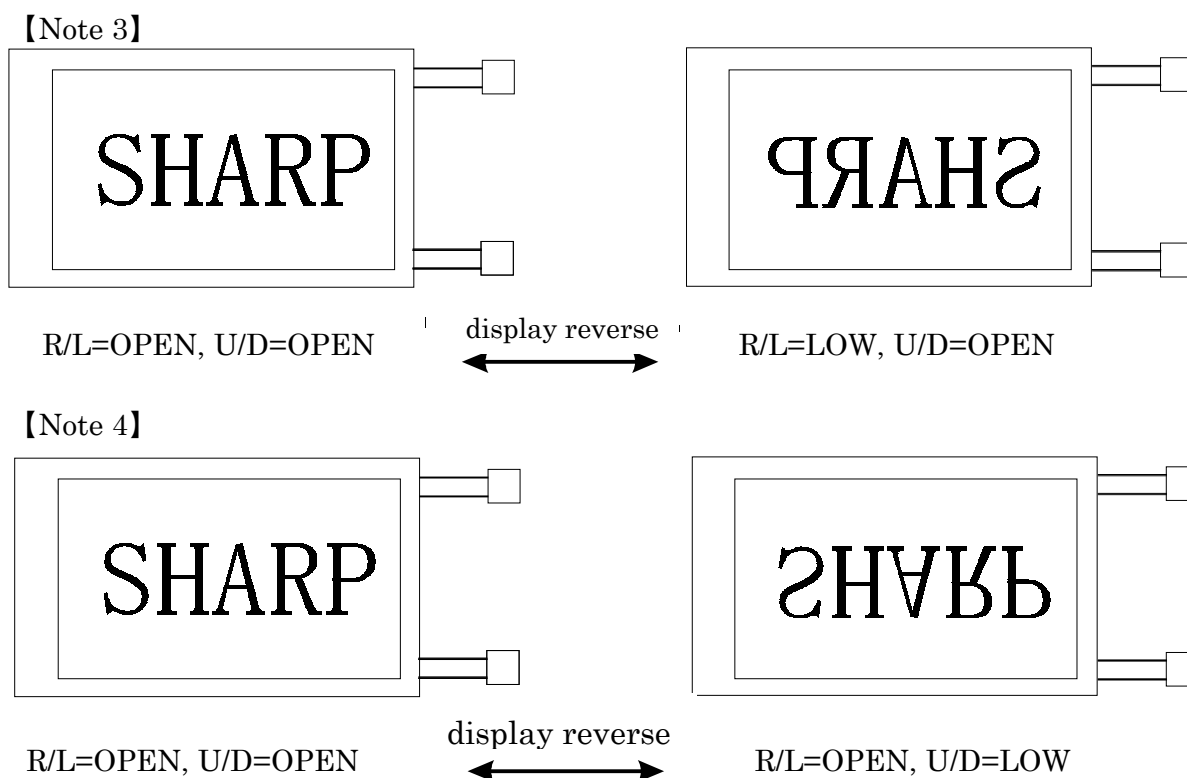

Fig.2 Display Reverse Function

4-2. Backlight Driving

Used connector : BHR-03VS-1(JST)

CNA,CNB

Corresponding connector : SM02(8.0)B-BHS(JST)

Pin no.	Symbol	Function
1	VHIGH	Power supply for lamp (High voltage side)
2	NC	This is electrically opened.
3	VLOW	Power supply for lamp (Low voltage side)

5. Absolute Maximum Ratings

Parameter	Symbol	Condition	Ratings	Unit	Remark
Input voltage	V _I	T _a =25°C	-0.3 ~ V _{CC} +0.3	V	【Note1】
+5V supply voltage	V _{CC}	T _a =25°C	0 ~ +6	V	—
Storage temperature	T _{stg}	—	-25 ~ +70	°C	【Note2】
Operating temperature (Ambient)	T _{opa}	—	0 ~ +55	°C	

【Note1】CK,R0~R5,G0~G5,B0~B5,Hsync,Vsync,ENAB,R/L,U/D

【Note2】Humidity:95%RH Max. at T_a≤40°C.Maximum wet-bulb temperature at 39°C or less at T_a>40°C.

No condensation.

6. Electrical Characteristics

6-1.TFT-LCD Panel Driving

Ta=25°C

Parameter	Symbol	Min.	Typ.	Max.	Unit	Remark	
+5V	Supply voltage	Vcc	+4.5	+5.0	+5.5	V	【Note1】
	Current dissipation	Icc	—	250	360	mA	【Note2】
Permissive input ripple voltage	V _{RF}	—	—	100	mVp-p	Vcc=+5V	
Input voltage (Low)	V _{IL}	—	—	0.3Vcc	V	【Note3】	
Input voltage (High)	V _{IH}	0.7Vcc	—	—	V		
Input current (low)	I _{OL1}	—	—	1.0	μA	V _I =0V 【Note4】	
	I _{OL2}	—	—	60.0	μA	V _I =0V 【Note5】	
Input current (High)	I _{OH1}	—	—	1.0	μA	V _I =Vcc 【Note6】	
	I _{OH2}	—	—	60.0	μA	V _I =Vcc 【Note7】	

【Note1】

Vcc-turn-on conditions

- t1 ≤ 15ms
- 0 < t2 ≤ 10ms
- 0 < t3 ≤ 10ms
- 0 < t4 ≤ 1s
- t5 > 1s

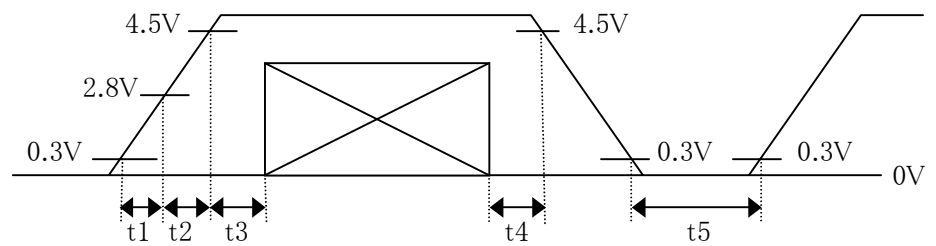

Vcc-dip conditions

- 1) 2.7V ≤ Vcc < 4.5V
td ≤ 10ms
- 2) Vcc < 2.7V

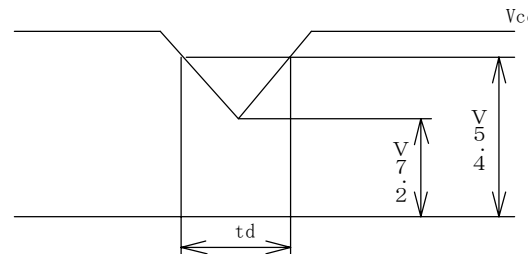

Fig.3 VCC-turn-on Conditions / VCC-dip-Conditions

※Vcc-dip conditions should also follow the Vcc-turn-on conditions

【Note2】Typical current situation : 16-gray-bar pattern.

480 line mode

Vcc=+5.0V

【Note3】CK,R0~R5,G0~G5,B0~B5,Hsync,Vsync,ENAB,R/L,U/D

【Note4】CK,R0~R5,G0~G5,B0~B5,Hsync,Vsync,ENAB

【Note5】R/L

【Note6】CK,R0~R5,G0~G5,B0~B5,Hsync,Vsync

【Note7】ENAB,U/D

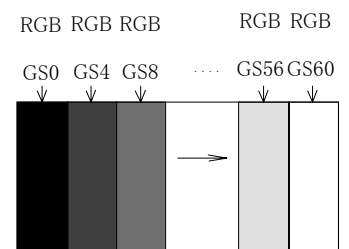

Fig.4 16-gray-bar Pattern

6-2. Backlight Driving

The backlight system is an edge-lighting type with double CCFT (Cold Cathode Fluorescent Tube).

The characteristics of single lamp are shown in the following table.

Ta=25°C

Parameter	Symbol	Min.	Typ.	Max.	Unit	Remark
Lamp current	IL	2.0	6.0	6.5	mArms	【Note1】
Lamp power consumption	PL	—	2.16	—	W	【Note2】
Lamp frequency	FL	20	35	60	KHz	【Note3】
Kick-off voltage	Vs	—	—	800	Vrms	Ta=25°C
		—	—	1000	Vrms	Ta=0°C【Note4】
Lamp life time	LL	—	50000	—	hour	【Note5】

【Note1】Lamp current is measured with current meter for high frequency as shown below.

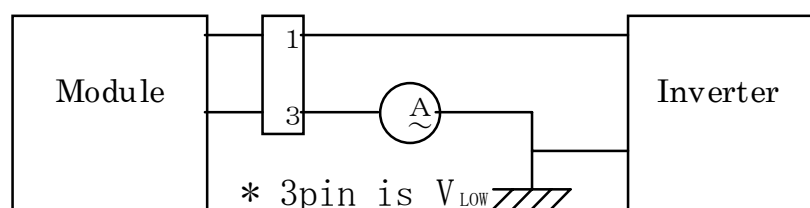

Fig.5 Measure Lamp Current

【Note2】At the condition of $Y_L = (300) \text{ cd/m}^2$

【Note3】Lamp frequency may produce interference with horizontal synchronous frequency, and this may cause beat on the display. Therefore lamp frequency shall be detached as much as possible from the horizontal synchronous frequency and from the harmonics of horizontal synchronous to avoid interference.

【Note4】The open output voltage of the inverter shall be maintained for more than 1sec; otherwise the lamp may not be turned on.

【Note5】a) Since lamp is consumables, the life time written above is referencial value and it is not guaranteed in this specification sheet by SHARP.

Lamp life time is defined that it applied either ①or②under this condition.

(Continuous turning on at Ta=25°C, IL=6mArms)

①Brightness becomes 50% of the original value under standard condition.

②Kick-off voltage at Ta=0°C exceeds maximum value,1000 Vrms.

b) In case of operating under lower temp. environment, the lamp exhaustion is accelerated and the brightness becomes lower.

(Continuous operating for around 1 month under lower temp. condition may reduce the brightness to half of the original brightness.)

In case of such usage under lower temp. environment, periodical lamp exchange is recommended.

Note) The performance of the backlight, for example life time or brightness, is much influenced by the characteristics of the DC-AC inverter for the lamp. When you design or order the inverter, please make sure that a poor lighting caused by the mismatch of the backlight and the inverter (miss-lighting, flicker, etc.) never occur. When you confirm it, the module should be operated in the same condition as it is installed in your instrument.

7. Timing Characteristics of Input Signals

Timing diagrams of input signal are shown in Fig.6-1~3.

7-1. Timing Characteristics

Parameter		Symbol	Mode	Min.	Typ.	Max.	Unit	Remark
Clock	Frequency	1/Tc	all	—	25.18	28.33	MHz	—
	High time	Tch	"	5	—	—	ns	—
	Low time	Tcl	"	10	—	—	ns	—
Data	Setup time	Tds	"	5	—	—	ns	—
	Hold time	Tdh	"	10	—	—	ns	—
Horizontal sync. signal	Cycle	TH	"	30.00	31.78	—	μ s	—
			"	770	800	900	clock	—
	Pulse width	THp	"	2	96	200	clock	—
Vertical sync. signal	Cycle	TV	480	515	525	560	line	—
			400	446	449	480	line	—
			350	447	449	510	line	—
	Pulse width	TVp	all	2	—	34	line	—
Horizontal display period	THd	"	640	640	640	clock	—	
Hsync-Clock phase difference	THc	"	10	—	Tc-10	ns	—	
Hsync-Vsync phase difference	TVh	"	0	—	TH-THp	clock	—	

Note) In case of lower frequency, the deterioration of display quality, flicker etc., may be occurred.

7-2. Horizontal Display Position

The horizontal display position is determined by ENAB signal and the input data corresponding to the rising edge of ENAB signal is displayed at the left end of the active area.

Parameter		symbol	Min.	Typ.	Max.	Unit	Remark
Enable signal	Setup time	Tes	5	—	Tc-10	ns	—
	Pulse width	Tep	2	640	640	clock	—
Hsync-Enable signal phase difference		THE	44	—	TH-664	clock	—

Note) When ENAB is fixed "Low", the display starts from the data of C104(clock) as shown in Fig.6-1~3. Be careful that the module does not work when ENAB is fixed "High".

When the phase difference is bellow 104 clock, keep the "High" level of ENAB signal longer than 104-THe. If it will not be kepted, the display starts from the data of C104(clock).

7-3. Vertical Display Position

The vertical display position is automatically centered in the active area at each

mode of VGA,480-,400-,and 350-line mode. Each mode is selected depending on the polarity of the synchronous signals described in 4-1(Note1).

In each mode,the data of TVn is displayed at the top line of the active area. And the display position will be centered on the screen like the following figure when the period of vertical synchronous signal,TV,is typical value.

In 400-,and 350-line mode,the data in the vertical data invalid period is also displayed.

So,inputting all data "0" is recommended during vertical data invalid period.

ENAB signal has no relation to the vertical display position.

mode	V-data start(TVs)	V-data period(TVd)	V-display start(TVn)	V-display period	Unit	Remark
480	34	480	34	480	line	—
400	34	400	443-TV	480	line	—
350	61	350	445-TV	480	line	—

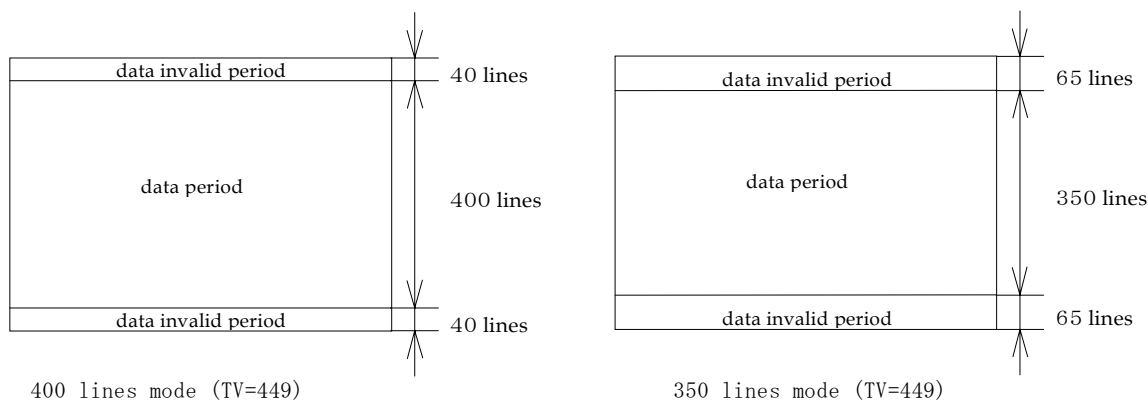

Fig.7 Vertical Data Area

7-4. Input Data Signals and Display Position on the Screen

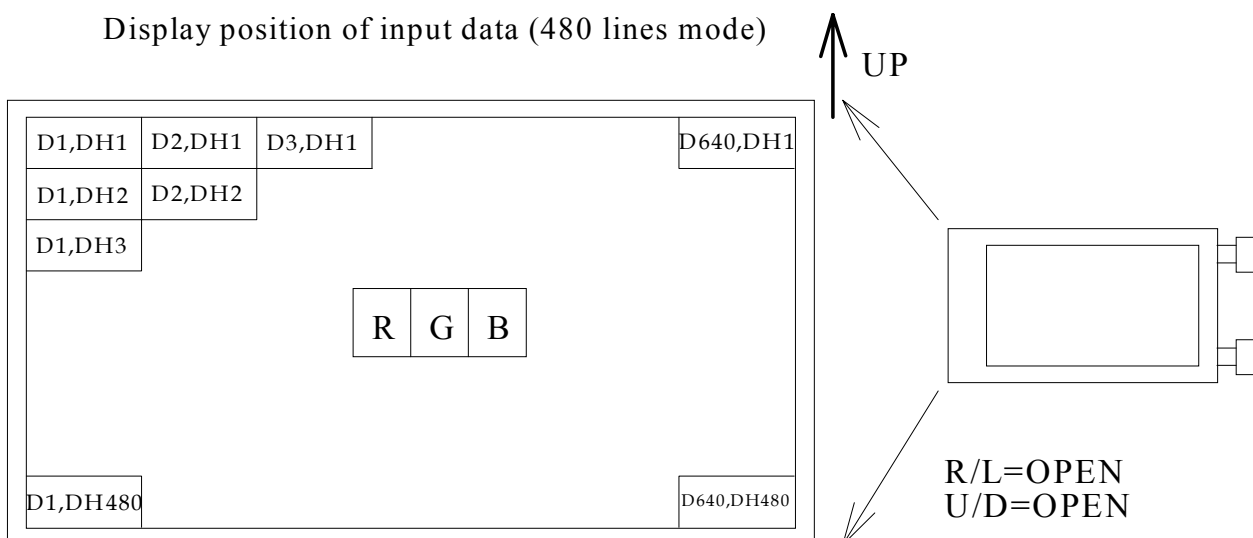

Fig.8 Display Position

8. Input Signals, Basic Display Colors and Gray Scale of Each Color

	Colors & Gray scale	Data signal																		
		GrayScale	R0	R1	R2	R3	R4	R5	G0	G1	G2	G3	G4	G5	B0	B1	B2	B3	B4	B5
Basic Color	Black	—	0	0	0	0	0	0	0	0	0	0	0	0	0	0	0	0	0	0
	Blue	—	0	0	0	0	0	0	0	0	0	0	0	0	1	1	1	1	1	1
	Green	—	0	0	0	0	0	0	1	1	1	1	1	1	0	0	0	0	0	0
	Cyan	—	0	0	0	0	0	0	1	1	1	1	1	1	1	1	1	1	1	1
	Red	—	1	1	1	1	1	1	0	0	0	0	0	0	0	0	0	0	0	0
	Magenta	—	1	1	1	1	1	1	0	0	0	0	0	0	1	1	1	1	1	1
	Yellow	—	1	1	1	1	1	1	1	1	1	1	1	1	0	0	0	0	0	0
	White	—	1	1	1	1	1	1	1	1	1	1	1	1	1	1	1	1	1	1
Gray Scale of Red	Black	GS0	0	0	0	0	0	0	0	0	0	0	0	0	0	0	0	0	0	0
	↑	GS1	1	0	0	0	0	0	0	0	0	0	0	0	0	0	0	0	0	0
	Darker	GS2	0	1	0	0	0	0	0	0	0	0	0	0	0	0	0	0	0	0
	↑	↓				↓					↓						↓			
	↓	↓				↓					↓						↓			
	Brighter	GS61	1	0	1	1	1	1	0	0	0	0	0	0	0	0	0	0	0	0
	↓	GS62	0	1	1	1	1	1	0	0	0	0	0	0	0	0	0	0	0	0
	Red	GS63	1	1	1	1	1	1	0	0	0	0	0	0	0	0	0	0	0	0
Gray Scale of Green	Black	GS0	0	0	0	0	0	0	0	0	0	0	0	0	0	0	0	0	0	0
	↑	GS1	0	0	0	0	0	0	1	0	0	0	0	0	0	0	0	0	0	0
	Darker	GS2	0	0	0	0	0	0	0	1	0	0	0	0	0	0	0	0	0	0
	↑	↓				↓					↓						↓			
	↓	↓				↓					↓						↓			
	Brighter	GS61	0	0	0	0	0	0	1	0	1	1	1	1	0	0	0	0	0	0
	↓	GS62	0	0	0	0	0	0	0	1	1	1	1	1	0	0	0	0	0	0
	Green	GS63	0	0	0	0	0	0	1	1	1	1	1	1	0	0	0	0	0	0
Gray Scale of Blue	Black	GS0	0	0	0	0	0	0	0	0	0	0	0	0	0	0	0	0	0	0
	↑	GS1	0	0	0	0	0	0	0	0	0	0	0	0	1	0	0	0	0	0
	Darker	GS2	0	0	0	0	0	0	0	0	0	0	0	0	0	1	0	0	0	0
	↑	↓				↓					↓						↓			
	↓	↓				↓					↓						↓			
	Brighter	GS61	0	0	0	0	0	0	0	0	0	0	0	0	1	0	1	1	1	1
	↓	GS62	0	0	0	0	0	0	0	0	0	0	0	0	0	1	1	1	1	1
	Blue	GS63	0	0	0	0	0	0	0	0	0	0	0	0	1	1	1	1	1	1

0 :Low level voltage, 1 : High level voltage

Each basic color can be displayed in 64 gray scales from 6 bit data signals. According to the combination of total 18 bit data signals, the 262,144-color display can be achieved on the screen.

9. Optical Characteristics

Ta=25°C, Vcc=+5V

Parameter		Symbol	Condition	Min.	Typ.	Max.	Unit	Remark
Viewing angle range	Horizontal	$\theta 21$	(CR \geq 5)	60	70	—	Deg.	【Note1,4】
		$\theta 22$		60	70	—	Deg.	
	Vertical	$\theta 11$		35	40	—	Deg.	
		$\theta 12$		55	70	—	Deg.	
Contrast ratio		CR	Best viewing	100	—	—	—	【Note2,4】
Response time	Rise	τr	$\theta = 0^\circ$	—	20	—	ms	【Note3,4】
	Decay	τd		—	40	—	ms	
Chromaticity of white		X		—	0.313	—	—	【Note4】
		Y		—	0.325	—	—	
Luminance of white		YL		240	300	—	cd/m ²	
White Uniformity		δ_w		—	—	1.45	—	【Note5】
Viewing angle Range as a brightness definition	Horizontal	$\theta 21$	50% of the maximum brightness	—	45	—	Deg.	【Note1】
		$\theta 22$		—	45	—	Deg.	
	Vertical	$\theta 11$		—	45	—	Deg.	
		$\theta 12$		—	45	—	Deg.	
Direction of panel viewing angle		—	—	6			o'clock	【Note6】

※ The measurement shall be executed 30 minutes after lighting at rating.

(typical condition:IL=6mArms)

The optical characteristics shall be measured in a dark room or equivalent state with the method shown in Fig.9 below.

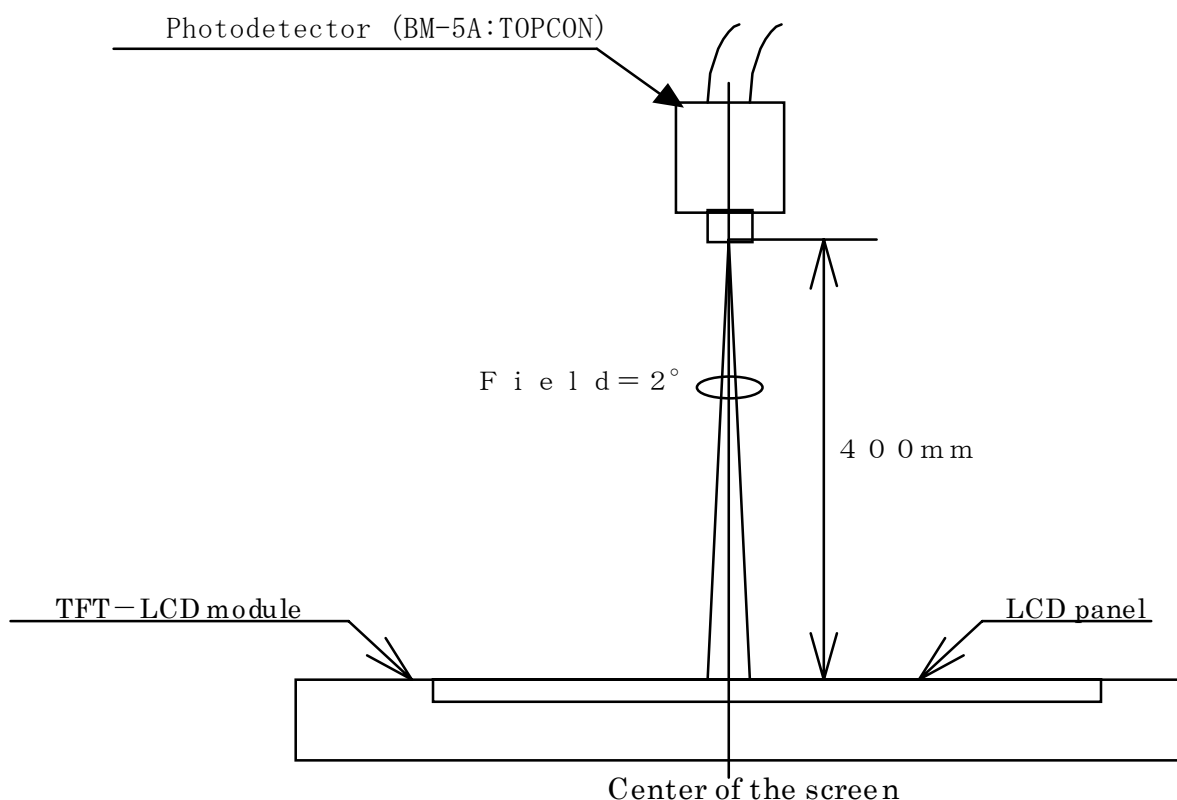

Fig.9 Optical characteristics measurement method

【Note1】 Definitions of viewing angle range:

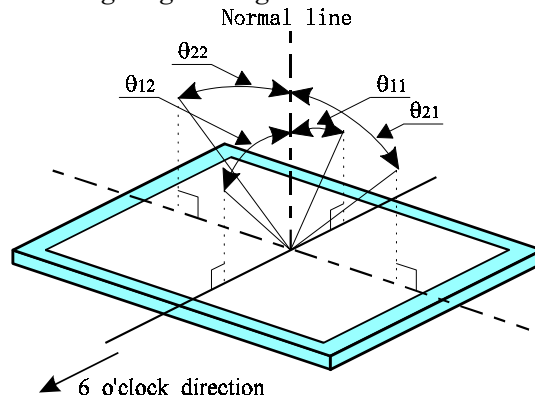

Fig.10 Viewing Angle

【Note2】 Definition of contrast ratio:

The contrast ratio is defined as the following.

$$\text{Contrast Ratio (CR)} = \frac{\text{Luminance (brightness) with all pixels white}}{\text{Luminance (brightness) with all pixels black}}$$

【Note3】 Definition of response time:

The response time is defined as the following figure and shall be measured by switching the input signal for "black" and "white" .

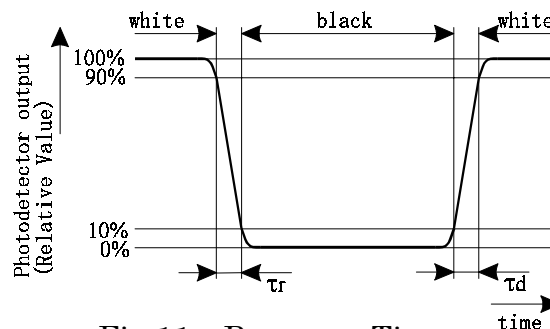

Fig.11 Response Time

【Note4】 This shall be measured at center of the screen.

【Note5】 Definition of white uniformity:

White uniformity is defined as the following with five measurements (A~E).

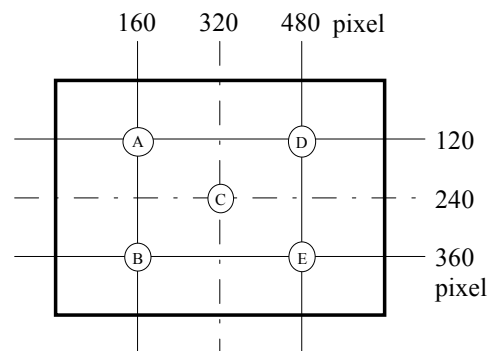

Fig.12 White Uniformity

$$\delta_w = \frac{\text{Maximum Luminance of five points (brightness)}}{\text{Minimum Luminance of five points (brightness)}}$$

【Note6】 In the direction of 6 o'clock, Gray scale reverse occurs.

10. Display Quality

The display quality of the color TFT-LCD module shall be in compliance with the Incoming Inspection Standard.

11. Handling Precautions

- a) Be sure to turn off the power supply when inserting or disconnecting the cable.
- b) Be sure to design the cabinet so that the module can be installed without any extra stress such as warp or twist.
- c) Since the front polarizer is easily damaged, pay attention to avoid rubbing with something hard or sharp.
- d) Wipe off water drop immediately. Long contact with water may cause discoloration or spots.
- e) When the panel surface is soiled, wipe it with absorbent cotton or other soft cloth.
- f) Since the panel is made of glass and refined wires and components, it may break, crack or internal wire breaking if dropped or bumped on hard surface. Handle with care.
- g) Since CMOS LSI is used in this module, take care of static electricity and injure the human earth when handling.
- h) Observe all other precautionary requirements in handling components.
- i) This module has its circuitry PCBs on the rear side and should be carefully handled in order not to be stressed.
- j) Laminated film is attached to the module surface to prevent it from being scratched. Peel the film off slowly, just before the use, with strict attention to electrostatic charges. Ionized air shall be blown over during the action. Blow off 'dust' on the polarizer by using an ionized nitrogen gun, etc.
- k) The polarizer surface on the panel is treated with Anti-Glare for low reflection. In case of attaching protective board over the LCD. Be careful about the optical interference fringe etc. Which degrades display quality.
- l) Please do not expose the LCD panel to direct sunlight. Lightproof shade etc. should be attached when LCD panel is used under such environment.
- m) Connect GND to 4 place of mounting holes to stabilize against EMI and external noise.
- n) There are high voltage portions on the backlight and very dangerous. Careless touch may lead to electrical shock. When you exchange lamps or service, please turn off the power without fail.
- o) Be sure not to apply tensile stress to the lamp lead cable.

12. Packing Form

Fig.13 shows packing forms.

- a) Piling number of cartons : MAX. 10
- b) Package quantity in one carton : 20pcs
- c) Carton size : 355(W) × 282(D) × 265(H)mm
- d) Total mass of 1 carton filled with full modules : 7.0kg

13. Reliability Test Items

No.	Test item	Conditions
1	High temperature storage test	Ta=70°C 240h
2	Low temperature storage test	Ta=-25°C 240h
3	High temperature & high humidity operation test	Ta=40°C ; 95%RH 240h (No condensation)
4	High temperature operation test	Ta=55°C 240h
5	Low temperature operation test	Ta=0°C 240h
6	Vibration test (non- operating)	Frequency : 10~57Hz/Vibration width (one side):0.075mm : 58~500Hz/Gravity:9.8m/s ² Sweep time : 11 minutes Test period : 3 hours (1 hour for each direction of X,Y,Z)
7	Shock test (non- operating)	Max. gravity : 490m/s ² Pulse width : 11ms, half sine wave Direction : ±X, ±Y, ±Z once for each direction.

【Result Evaluation Criteria】

Under the display quality test conditions with normal operation state, these shall be no change which may affect practical display function.

14. Others

1) Lot No. Label:

LQ64D343	7900001
Model No.	Lot No.

- 2) Adjusting volume have been set optimally before shipment, so do not change any adjusted value. If adjusted value is changed, the specification may not be satisfied.
- 3) Disassembling the module can cause permanent damage and should be strictly avoided.
- 4) Please be careful since image retention may occur when a fixed pattern is displayed for a long time.
- 5) If any problem occurs in relation to the description of this specification , it shall be resolved through discussion with spirit of cooperation.
- 6) Do not use LCD module in the atmosphere of corrosive gases, such as sulfide gas or chlorine gases. Polarizer may be deteriorated or cause chemical reaction that can lead to short circuits at the terminal points. Do not use the material, which compounds contain sulfide or chlorine articles in the vicinity of LCD module. At high temperature, these compounds produce corrosive gases.

15. Exchange of Lamps

The lamp in the LCD module is comsumble and when needed, please replace them in accordance with following 1)–4) procedure.

- 1) Loosening the 4 screws which fix white lamp holders. (Refer to Fig.14)
- ※ Screw are not attached in the spare parts lamp unit. Please take care not to lose them.
- 2) Remove the white white lamp holders loosening the click by shifting the holder to “A” direction slightly and draw it to “B” direction. (Refer to Fig.15)
- ※ Forcible removing makes the lamp holder damaged, especially click portion is weak.
- 3) Not only one side, both side should be exchanged.
- 4) When reassemble, take a reverse order in above 1) to 3).
- ※ Both lamp units have same structure and possible to install them in reverse. Please be careful of the lamp lead wire direction.

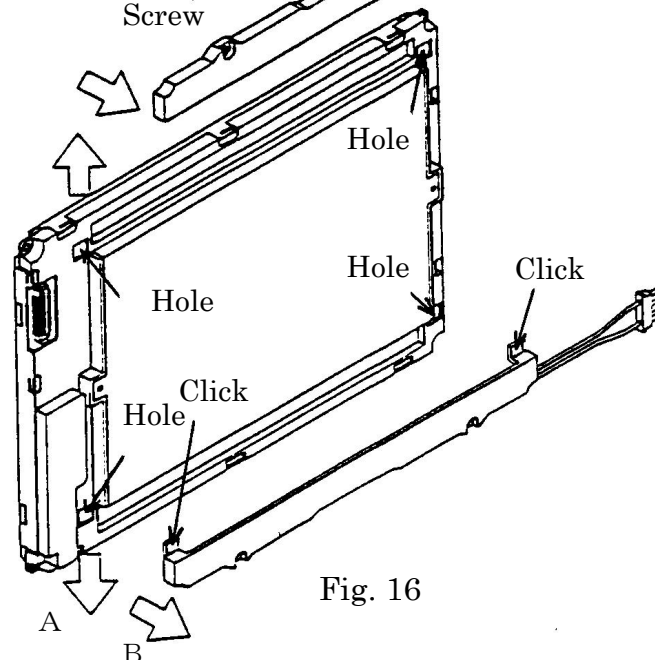
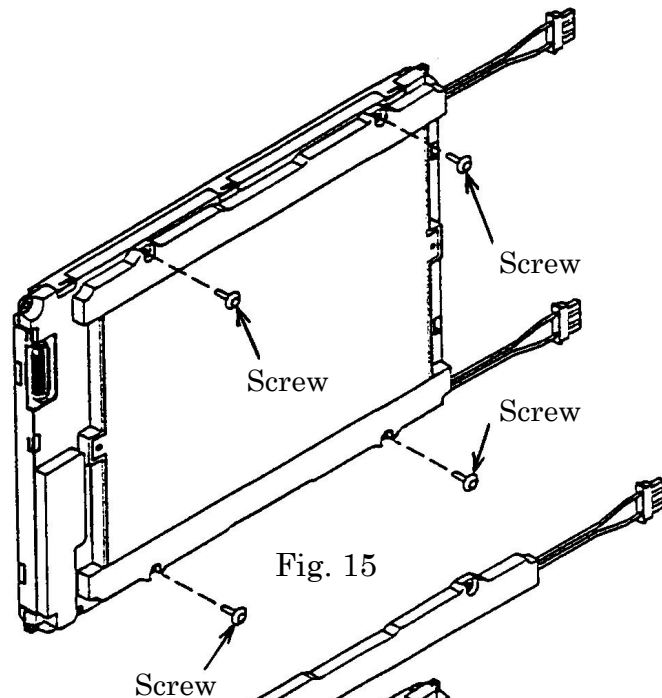

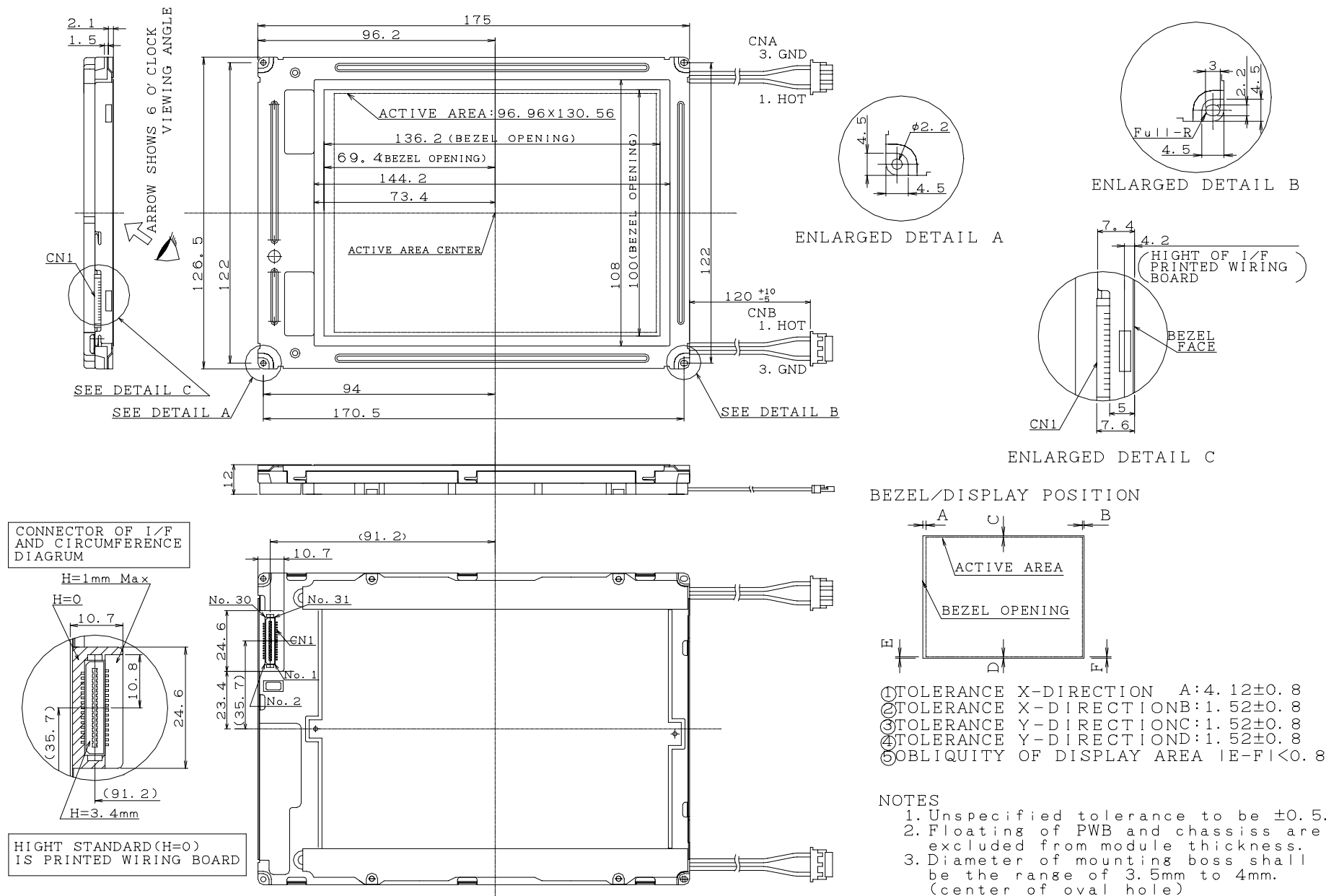

Fig.1 Outline Dimensions

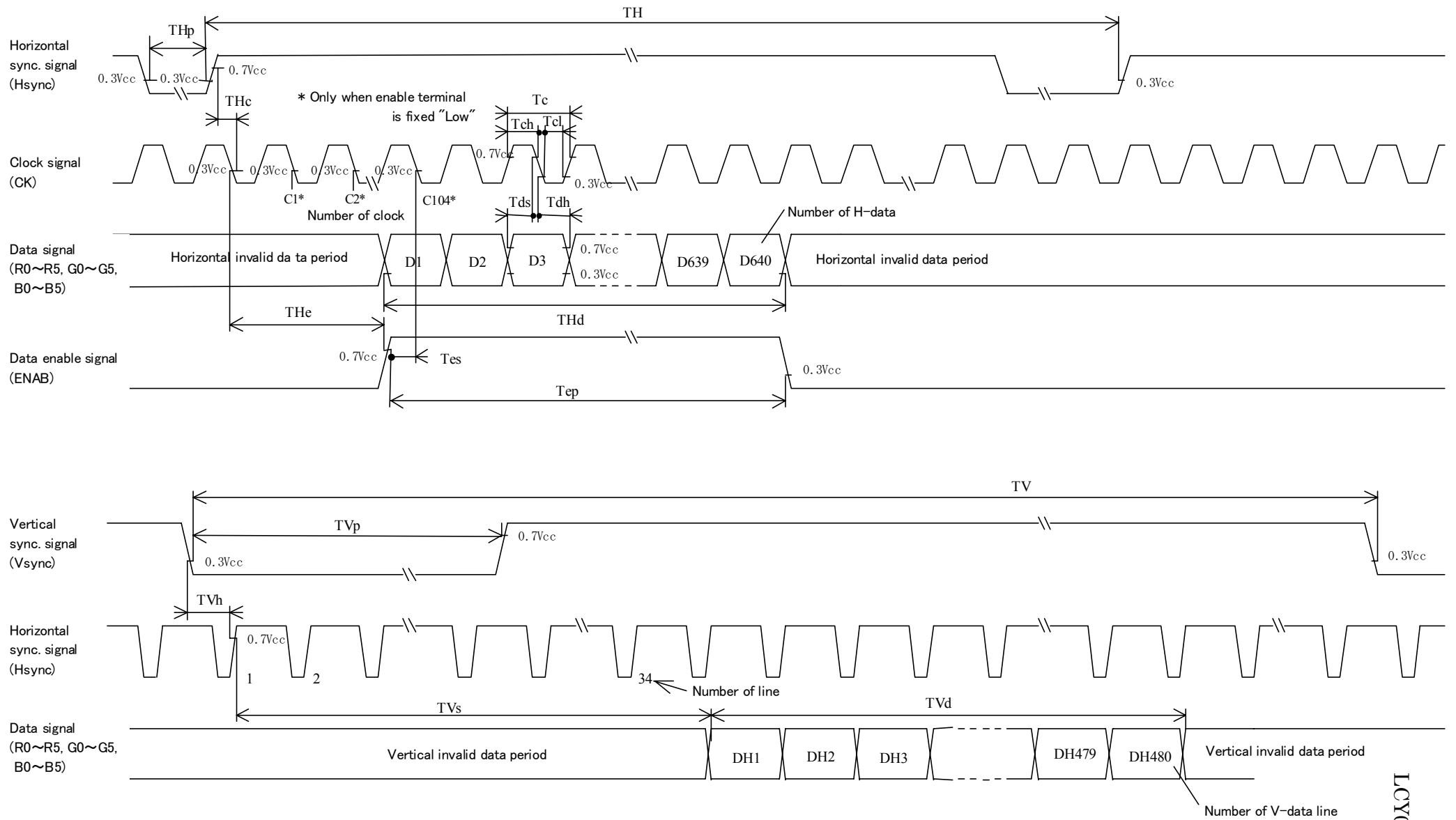

Fig. 6-1 Input signal waveforms (480 line mode)

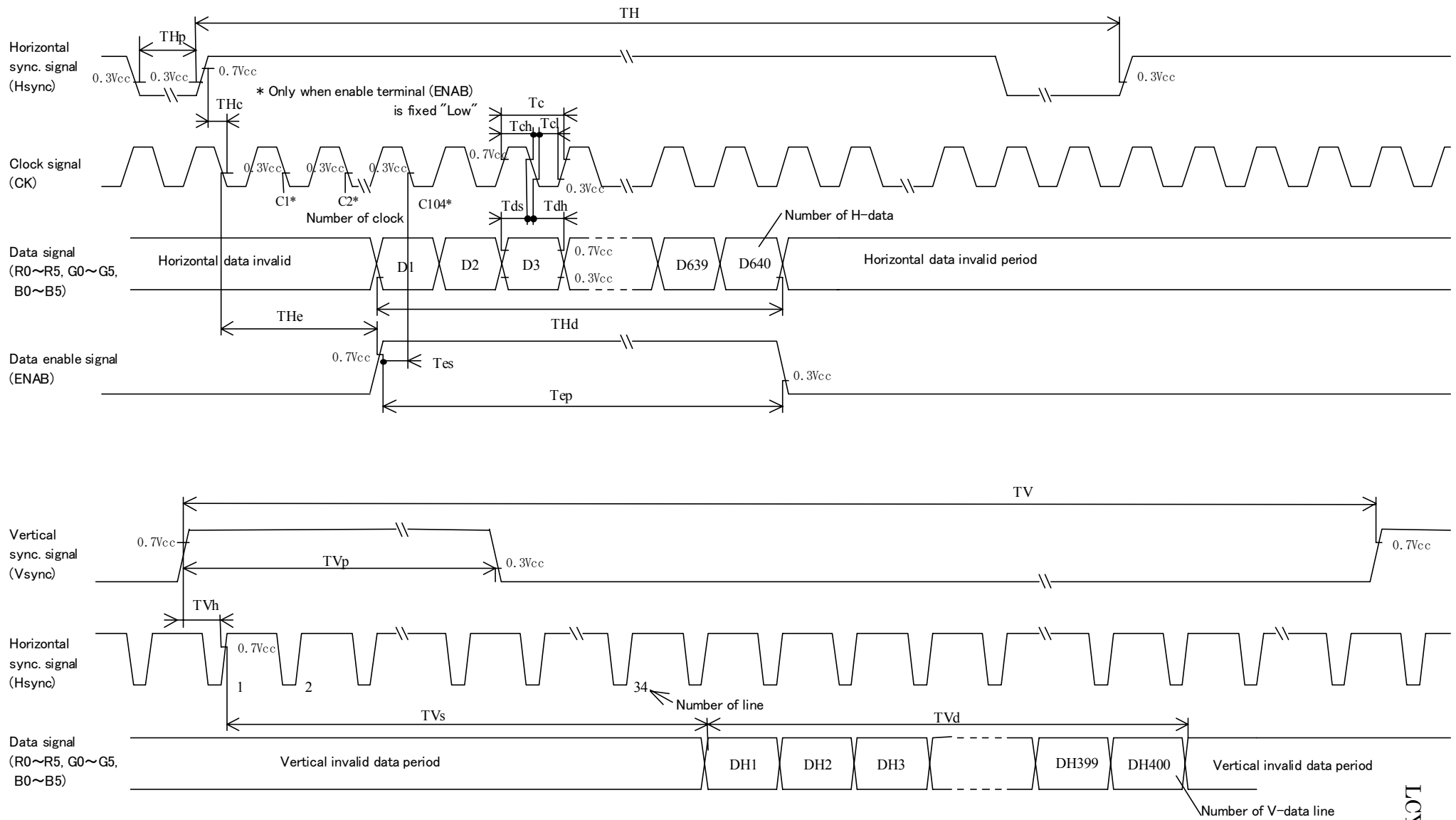

Fig.6-2 Input signal waveforms (400 line mode)

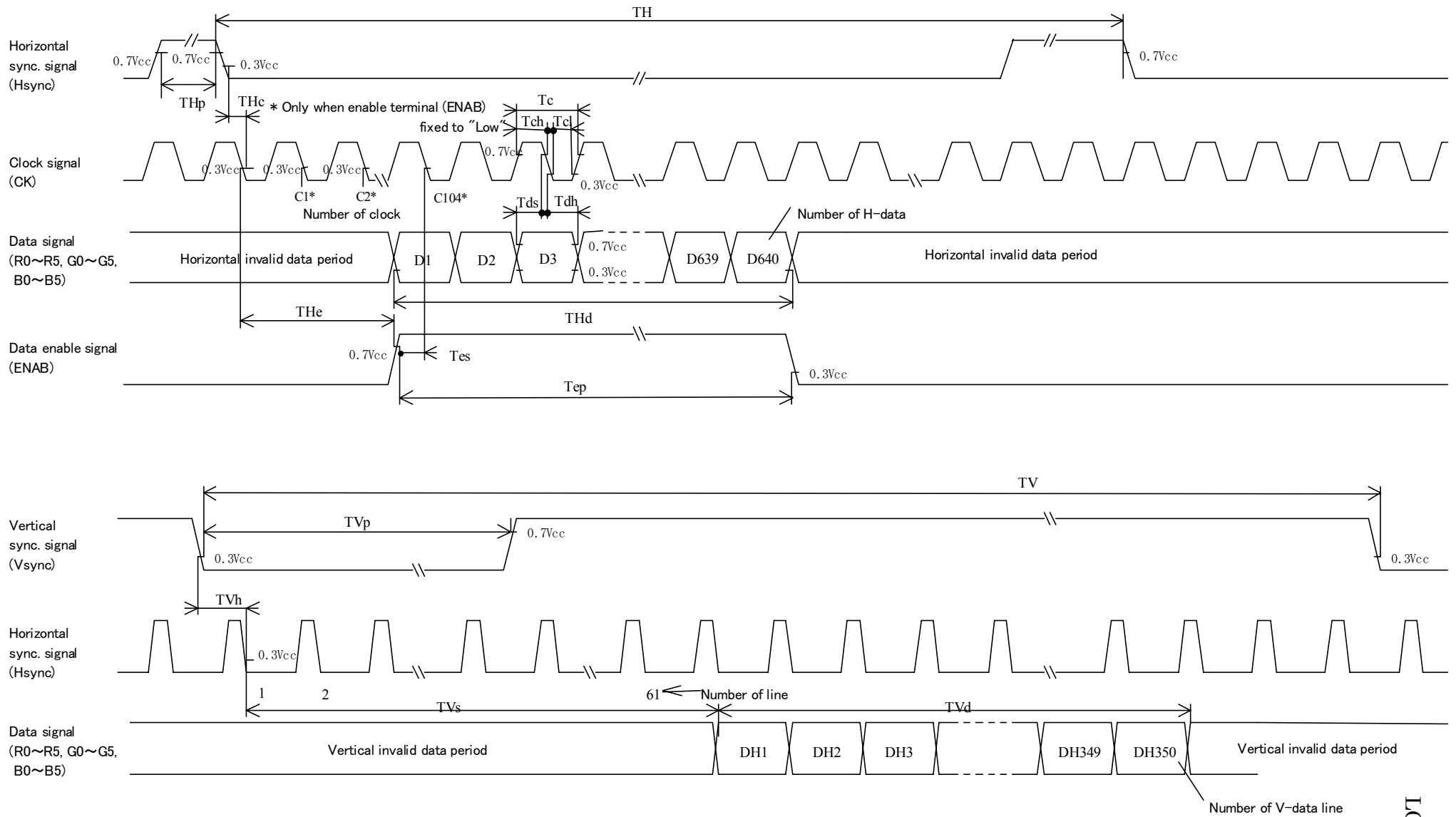

Fig.6-3 Input signal waveforms (350 line mode)

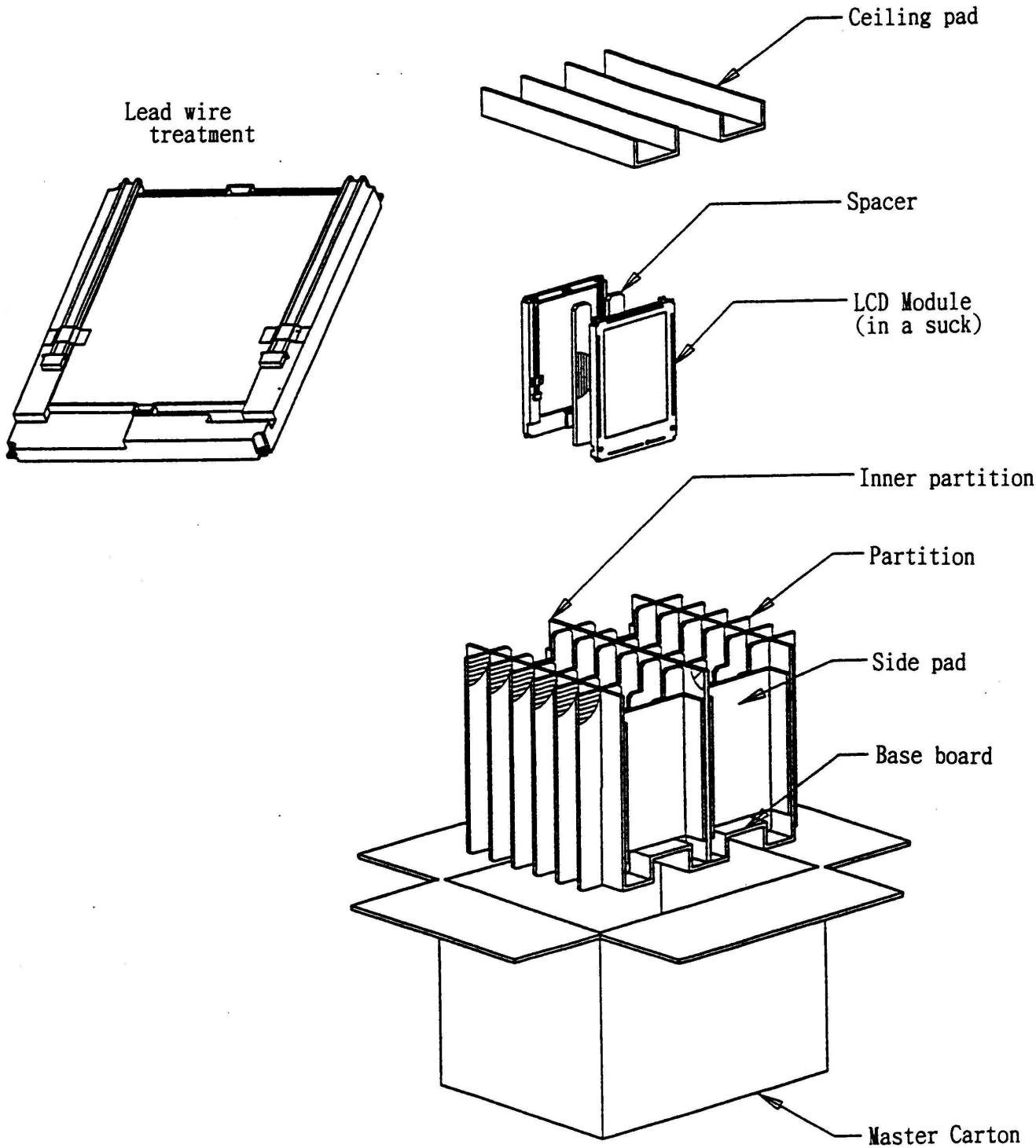

Fig.13 Packing Forms

SPECIFICATIONS ARE SUBJECT TO CHANGE WITHOUT NOTICE.

Suggested applications (if any) are for standard use; See Important Restrictions for limitations on special applications. See Limited Warranty for SHARP's product warranty. The Limited Warranty is in lieu, and exclusive of, all other warranties, express or implied. ALL EXPRESS AND IMPLIED WARRANTIES, INCLUDING THE WARRANTIES OF MERCHANTABILITY, FITNESS FOR USE AND FITNESS FOR A PARTICULAR PURPOSE, ARE SPECIFICALLY EXCLUDED. In no event will SHARP be liable, or in any way responsible, for any incidental or consequential economic or property damage.

SHARP®

NORTH AMERICA

SHARP Microelectronics of the Americas
5700 NW Pacific Rim Blvd.
Camas, WA 98607, U.S.A.
Phone: (1) 360-834-2500
Fax: (1) 360-834-8903
Fast Info: (1) 800-833-9437
www.sharpsma.com

EUROPE

SHARP Microelectronics Europe
Division of Sharp Electronics (Europe) GmbH
Sonninstrasse 3
20097 Hamburg, Germany
Phone: (49) 40-2376-2286
Fax: (49) 40-2376-2232
www.sharpsme.com

JAPAN

SHARP Corporation
Electronic Components & Devices
22-22 Nagaike-cho, Abeno-Ku
Osaka 545-8522, Japan
Phone: (81) 6-6621-1221
Fax: (81) 6117-725300/6117-725301
www.sharp-world.com

TAIWAN

SHARP Electronic Components
(Taiwan) Corporation
8F-A, No. 16, Sec. 4, Nanking E. Rd.
Taipei, Taiwan, Republic of China
Phone: (886) 2-2577-7341
Fax: (886) 2-2577-7326/2-2577-7328

SINGAPORE

SHARP Electronics (Singapore) PTE., Ltd.
438A, Alexandra Road, #05-01/02
Alexandra Technopark,
Singapore 119967
Phone: (65) 271-3566
Fax: (65) 271-3855

KOREA

SHARP Electronic Components
(Korea) Corporation
RM 501 Geosung B/D, 541
Dohwa-dong, Mapo-ku
Seoul 121-701, Korea
Phone: (82) 2-711-5813 ~ 8
Fax: (82) 2-711-5819

CHINA

SHARP Microelectronics of China
(Shanghai) Co., Ltd.
28 Xin Jin Qiao Road King Tower 16F
Pudong Shanghai, 201206 P.R. China
Phone: (86) 21-5854-7710/21-5834-6056
Fax: (86) 21-5854-4340/21-5834-6057

Head Office:

No. 360, Bashen Road,
Xin Development Bldg. 22
Waigaoqiao Free Trade Zone Shanghai
200131 P.R. China
Email: smc@china.global.sharp.co.jp

HONG KONG

SHARP-ROXY (Hong Kong) Ltd.
3rd Business Division,
17/F, Admiralty Centre, Tower 1
18 Harcourt Road, Hong Kong
Phone: (852) 28229311
Fax: (852) 28660779
www.sharp.com.hk

Shenzhen Representative Office:

Room 13B1, Tower C,
Electronics Science & Technology Building
Shen Nan Zhong Road
Shenzhen, P.R. China
Phone: (86) 755-3273731
Fax: (86) 755-3273735