

PREPARED BY: DATE

APPROVED BY: DATE

SHARP

LIQUID CRYSTAL DISPLAY GROUP
SHARP CORPORATION

SPECIFICATION

SPEC No. LD-5X02C

FILE No.

ISSUE: Oct. 12. 1993

PAGE : 16 pages

APPLICABLE GROUP

Liquid Crystal Display
Group

DEVICE SPECIFICATION FOR

TFT-LCD Module

MODEL No.

LQ9D021

CUSTOMER'S APPROVAL

DATE

BY

PRESENTED

BY

H. FUKUOKA

Department General Manager

Engineering Department 2

TFT Development Center

LIQUID CRYSTAL DISPLAY GROUP

SHARP CORPORATION

RECORDS OF REVISION

SPEC No.	DATE	REVISED No.	SUMMARY		NOTE
			PAGE		
LD-5X02		-	-		1st Issue
LD-5X02A	Dec. 09, '93	A	16	Addition of Note and dimension of holes.	2nd Issue
LD-5X02B	Dec. 21, '93	B	1	Addition of Screen size (8.4").	3rd Issue
			1	Effective display area. → Active area.	
			1	Modification of Outline dimensions (H).	
			3	Modification of Backlight connector number "CNA → CN2".	
LD-5X02C	Nov. 02, '94	C	7. 8. 9	Fig. 2 Input signal waveform (Corrected)	4th Issue
			11	Fig. 3 Photodetector BM-7→BM-5A (Changed)	
			13	9-3) a) (Added)	
			14	12. 5) (Added)	
			15	Fig. 4 Packing form. (Changed)	

1. Application

This specification applies to color TFT-LCD module, LQ9D021.

2. Overview

This module is a color active matrix LCD module incorporating amorphous silicon TFT (Thin Film Transistor). It is composed of a color TFT-LCD panel, driver ICs, control circuit and power supply circuit and a backlight unit. Graphics and texts can be displayed on a 640x3x480 dots panel in 512 colors by supplying 9 bit data signal, four

kinds of timing signals, +5V DC supply voltage for TFT-LCD panel driving and supply voltage for backlight. Optimum viewing angle direction is 6 o'clock.

400 lines and 350 lines modes in addition to the 480 lines mode can be also applied for this module.

Backlight-driving DC/AC inverter is not built in this module.

3. Mechanical Specifications

Parameter	Specifications	Unit
Screen size (Diagonal)	21 (8.4")	cm
Active area	170.9(H)×129.6(V)	mm
Display pixels	640(H)×480(V) (1 pixel=R+G+B dots)	pixel
Pixel pitch	0.267(H)×0.270(V)	mm
Pixel configuration	R, G, B vertical stripe	
Display mode	Normally white	
Unit outline dimensions *1	242.5(W)×179.4(H)×8.7(D)	mm
Weight	485±20	g
Surface treatment	anti-glare and hard-coating 2H	

*1. Note: excluding backlight cables.

Outline dimensions is shown in Fig.1

4. Input Terminals

4-1) TFT-LCD panel driving

CN1 (Interface signal)

Used connector:DF9B-31P-1V (Hirose Electric Co., Ltd.)

Corresponding connector:DF9B-31S-1V ()

Pin No.	Symbol	Function	Remark
1	TST	This should be electrically opened during operation	
2	GND		
3	R0	RED data signal (LSB)	
4	Vsync	vertical sync signal	【Note1】
5	R1	RED data signal	
6	Hsync	Horizontal sync signal	【Note1】
7	R2	RED Data signal (MSB)	
8	GND		
9	GND		
10	CK	Clock signal for sampling each data signal	
11	TST	This should be electrically opened during operation	
12	GND		
13	G0	GREEN Data signal (LSB)	
14	TST	This should be electrically opened during operation	
15	GND		
16	TST	This should be electrically opened during operation	
17	G1	GREEN Data signal	
18	TST	This should be electrically opened during operation	
19	G2	GREEN data signal (MSB)	
20	GND		
21	GND		
22	VCC	+5V power supply	
23	TST	This should be electrically opened during operation	
24	VCC	+5V power supply	
25	B0	BLUE data signal (LSB)	
26	TST	This should be electrically opened during operation	
27	GND		
28	ENAB	Data enable signal(to settle the viewing area)	
29	B1	BLUE data signal	
30	GND		
31	B2	BLUE data signal (MSB)	

【Note1】 Polarity of the sync.
signals.

mode	430 lines	400 lines	350 lines
Hsync	negative	negative	positive
Vsync	negative	positive	negative

※The shielding case is connected with GND.

30		4	2
31		3	1

CN1 Pin arrangement

Used connector : BHR-03VS-1(JST)

Corresponding connector:SM02(8.0)B-BHS(JST)

CN2

Pin no.	symbol	function
1	V _{HIGH}	Power supply for lamp (High voltage side)
3	V _{LOW}	Power supply for lamp (Low voltage side)

5. Absolute Maximum Ratings

Parameter	Symbol	Condition	Ratings	Unit	Remark
Input voltage	V _I	Ta=25°C	-0.3 ~ V _{CC} +0.3	V	【Note1】
+5V supply voltage	V _{CC}	Ta=25°C	-0.3 ~ +7	V	
Storage temperature	T _{stg}	-	-25 ~ +60	°C	【Note2】
Operating temperature (Ambient)	T _{opa}	-	0 ~ +50	°C	

【Note1】 CK, R0~R2, G0~G2, B0~B2, Hsync, Vsync, ENAB

【Note2】 Humidity : 95%RH Max. at Ta≤40°C.

Maximum wet-bulb temperature 39°C or less at Ta>40°C.

No condensation.

6. Electrical Characteristics

6-1. Electrical Characteristics & current dissipation

6-1-a) TFT-LCD panel driving

Ta=25°C

Parameter	Symbol	Min.	Typ.	Max.	Unit	Remark
+5V Supply voltage	V _{CC}	+4.5	+5.0	+5.5	V	【Note1】
	I _{CC}	-	200	350	mA	【Note2】
Permissive input ripple voltage	V _{RF}	-	-	100	mVp-p	V _{CC}
Input voltage (Low)	V _{IL}	-	-	1.5	V	V _{CC} =+5V
Input voltage (High)	V _{IH}	+3.5	-	-	V	【Note3】
Input current (low)	I _{IL}	-	-	1.0	μA	V _I =0V 【Note4】
Input current (High)	I _{IH1}	-	-	1.0	μA	V _I =V _{CC} 【Note3】
	I _{IH2}	-	-	+60	μA	【Note5】

【Note1】

Vcc-turn-on conditions

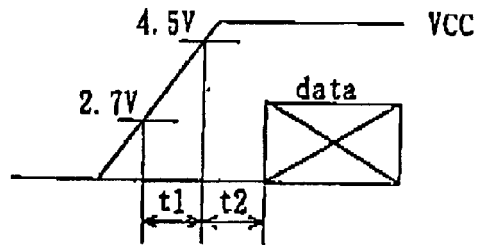
t1: rise time ($\leq 10\text{msec}$)t2: data input allowance time ($\leq 10\text{msec}$)

Vcc-dip conditions

1) $2.7\text{V} \leq V_{cc} < 4.5\text{V}$

td = 10ms Max

2) $V_{cc} < 2.7\text{V}$

(Vcc-dip conditions are same as the Vcc-turn-on conditions)

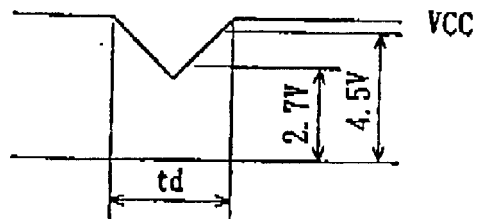

【Note2】 Typical current situation is defined 8-gray-bar pattern.

(at 480 lines mode. $V_{cc}=5\text{V}$)

【Note3】 CK, R0~R2, G0~G2, B0~B2, Hsync, Vsync, ENAB

【Note4】 CK, R0~R2, G0~G2, B0~B2, Hsync, Vsync

【Note5】 ENAB

6-1-b) Backlight

The backlight system is an edge lighting type. (a CCFT)

The characteristics of single lamp are shown in the following table.

 $T_a=25^\circ\text{C}$

Parameter	Symbol	Min.	Typ.	Max.	Unit	Remark
Lamp voltage	V_L	-	450	-	Vrms	Just for reference
Lamp current	I_L	4.5	5.0	5.5	mA rms	
Lamp power consumption	P_L	-	2.25	-	W	【Note 1】
Frequency	F_L	20	-	60	kHz	【Note 2】
Kick-off voltage	V_s	-	-	1400	Vrms	$T_a=0^\circ\text{C}$
Lamp life time	T_L	-	10000	-	hour	【Note 3】

【Note 1】 Calculated value for reference. ($I_L \times V_L$)

【Note 2】 Lamp frequency may produce interference with horizontal sync. frequency, and interference may cause beat on the display

Therefore lamp frequency shall be as different as possible from the ones of Horizontal sync. and harmonics horizontal sync. to avoid interference.

【Note 3】 Brightness becomes 50% of the original value under standard condition. ($I_L=5.0\text{mA rms}$)

6-2. Timing Characteristics of input signals

※Input signal waveforms are shown in Fig. 2-①~③.

6-2-a) Timing characteristics

Parameter	Symbol	Mode	Min.	Typ.	Max.	Unit	Remark
Clock	Frequency	1/Tc	all	—	25.18	28.33	MHz
	High time	Tch	'	5	—	—	ns
	Low time	Tcl	'	10	—	—	ns
Data	Setup time	Tds	'	5	—	—	ns
	Hold time	Tdh	'	10	—	—	ns
Horizontal sync. signal	Cycle	TH	'	30.00	31.78	—	μs
			'	770	800	900	clock
	Pulse width	THp	'	2	96	200	clock
Vertical sync. signal	Cycle	TV	480	515	525	560	line
			400	445	449	480	line
			350	447	449	510	line
	Pulse width	TVp	all	2	—	34	line
Horizontal display period	THd	'	640	640	640	clock	
Hsync. -Clock phase difference	THc	'	10	—	Tc-10	ns	
Hsync. -Vsync. phase difference	TVh	'	0	—	TH-THp	ns	

Note) In case of lower frequency, the deterioration of display quality, flicker etc. may be occurred.

6-2-b) Horizontal display position and Data enable signal

6-2-b)-i) In case of the data enable signal is input.

The horizontal display starts from rising of the data enable signal.

Parameter	Symbol	Mode	Min.	Typ.	Max.	Unit	Remark
Enable signal	Setup time	Tes	all	5	—	Tc-10	ns
	Pulse width	Tep	'	2	640	640	clock
Hsync. -Enable signal phase difference	THE	'	44	—	164	clock	

6-2-b)-i) In case of the data enable terminal (ENAB) is fixed "Low".

The horizontal display starts from the data of C104(clock) as shown in Fig. 2.

6-2-c) Vertical display position

The vertical display position is centered in 480 line, 400 line and 350 line modes of VGA with the polarity of the sync. signals and values in the following table.

The data enable signal doesn't effect the vertical display position.

mode	V-data start(TVs)	V-data period(TVd)	V-display start	V-display period	Unit	Remark
480	34	480	34	480	line	
400	34	400	443-TV	480	line	[Notel]
350	61	350	445-TV	480	line	

[Notel] Since during vertical data invalid period is displayed in 400 and 350 line modes, inputting all data "0" is recommended during vertical data invalid period. (refer to the following figure)

In 400 and 350 lines modes, the display position won't be centered on the screen if the vertical sync. signal, TV, doesn't have above typical values.

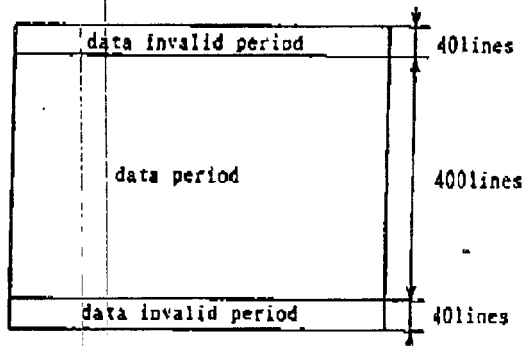

400 lines mode (TV-449)

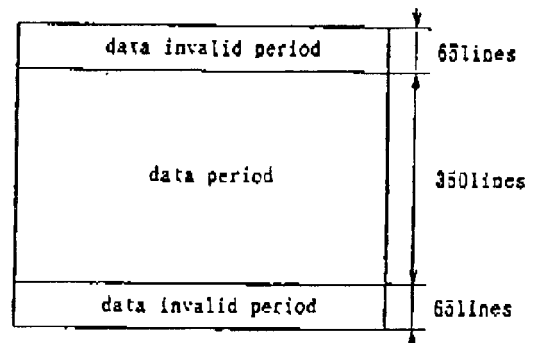

350 lines mode (TV-449)

6-3. Input Data Signals and Display Position on the screen

Display position of input data (480 lines mode)
(H·V)

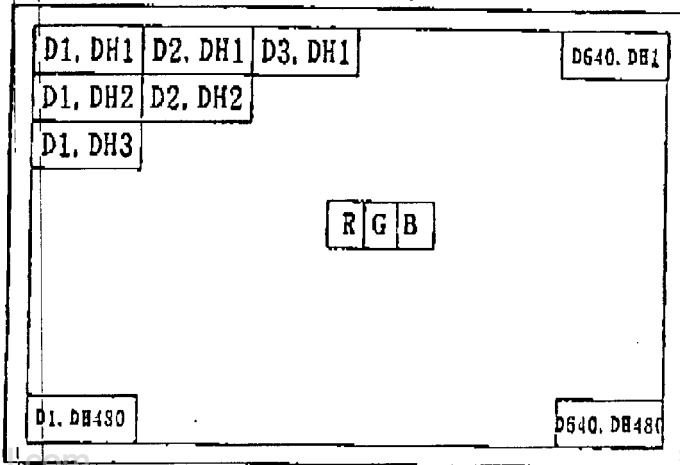

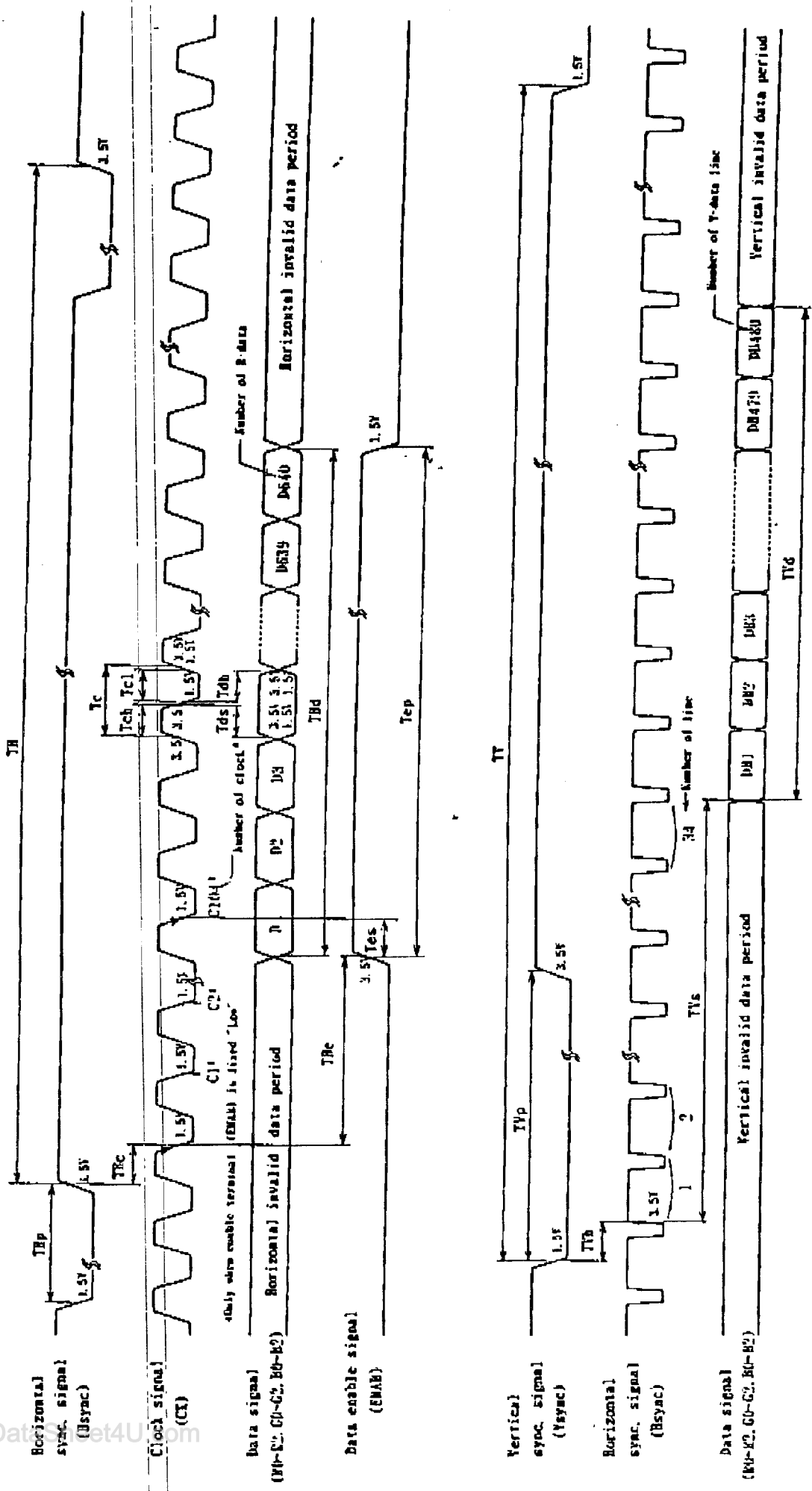

Fig. 2-6 Input signal waveforms (480 line mode)

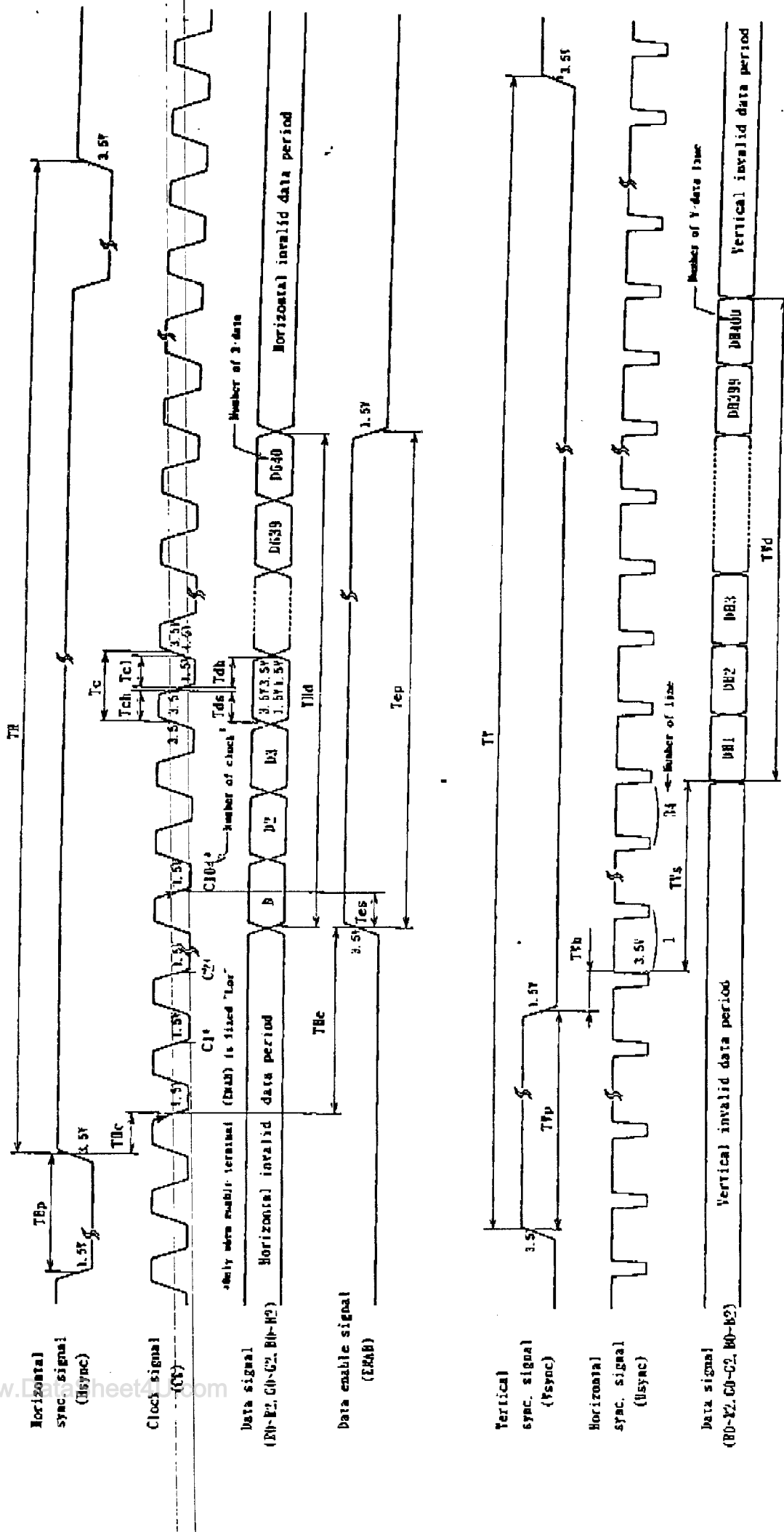

Fig. 2-2 Input signal waveforms (400 line mode)

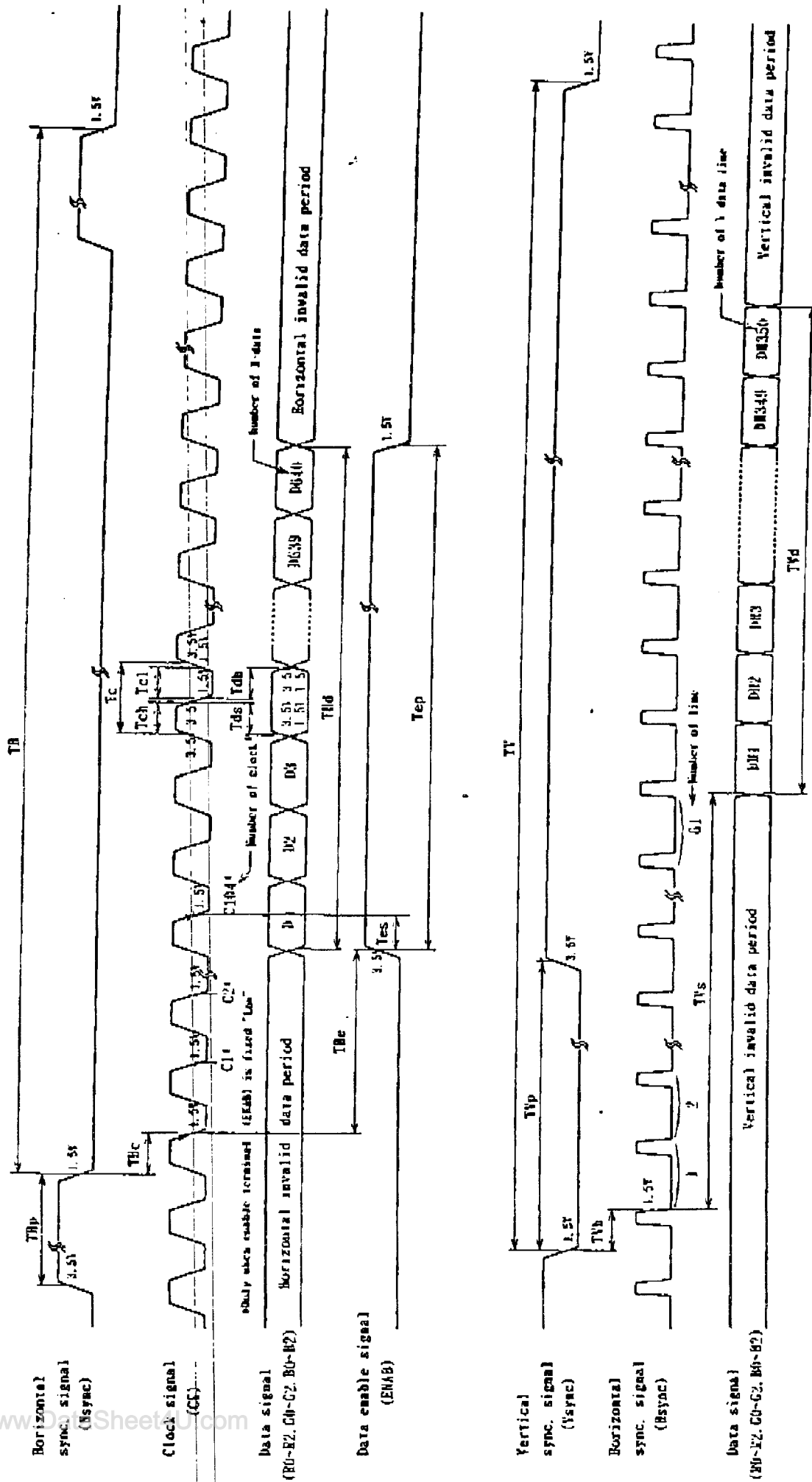

Fig. 2-6 Input signal waveforms (350 line mode)

6-4. Input Signals, Basic Display Colors and Gray Scale of Each Color

	color & Gray scale	Data signal								
		R0	R1	R2	G0	G1	G2	B0	B1	B2
Basic color	Black	0	0	0	0	0	0	0	0	0
	Blue	0	0	0	0	0	0	1	1	1
	Green	0	0	0	1	1	1	0	0	0
	Light blue	0	0	0	1	1	1	1	1	1
	Red	1	1	1	0	0	0	0	0	0
	Purple	1	1	1	0	0	0	1	1	1
	Yellow	1	1	1	1	1	1	0	0	0
	White	1	1	1	1	1	1	1	1	1
Gray Scale of Red	Black	0	0	0	0	0	0	0	0	0
	↑	1	0	0	0	0	0	0	0	0
	Darker	0	1	0	0	0	0	0	0	0
	↑	1	1	0	0	0	0	0	0	0
	↓	0	0	1	0	0	0	0	0	0
	Brighter	1	0	1	0	0	0	0	0	0
	↓	0	1	1	0	0	0	0	0	0
Red	1	1	1	0	0	0	0	0	0	
Gray Scale of Green	Black	0	0	0	0	0	0	0	0	0
	↑	0	0	0	1	0	0	0	0	0
	Darker	0	0	0	0	1	0	0	0	0
	↑	0	0	0	1	1	0	0	0	0
	↓	0	0	0	0	0	1	0	0	0
	Brighter	0	0	0	1	0	1	0	0	0
	↓	0	0	0	0	1	1	0	0	0
Green	0	0	0	1	1	1	0	0	0	
Gray Scale of Blue	Black	0	0	0	0	0	0	0	0	0
	↑	0	0	0	0	0	0	1	0	0
	Darker	0	0	0	0	0	0	0	1	0
	↑	0	0	0	0	0	0	1	1	0
	↓	0	0	0	0	0	0	0	0	1
	Brighter	0	0	0	0	0	0	1	0	1
	↓	0	0	0	0	0	0	0	1	1
Blue	0	0	0	0	0	0	1	1	1	

0: Low level
voltage
1: High level
voltage

Each color is displayed in 8 gray scales from 3 bit data signals input. According to the combination of total 9 bit data, 512 colors are displayed.

7. Optical Characteristics

Ta=25°C, Vcc=+5V

Parameter	Symbol	Condition	Min.	Typ.	Max.	Unit	Remark	
Viewing angle range	Horizontal	$\theta 21.22$	CR > 10	3.5	-	-	Deg.	【Note1.4】
	Vertical	$\theta 11$		1.0	-	-	Deg.	
		$\theta 12$		3.0	-	-	Deg.	
Contrast ratio	CR	Optimum viewing angle	6.0	-	-		【Note2.4】	
Response time	Rise	τr	$\theta = 0^\circ$	-	3.0	-	ms	【Note3.4】
	Decay	τd		-	5.0	-	ms	
Chromaticity of color	white	x_w	-	0.300	-		【Note4】	
		y_w	-	0.311	-			
Luminance of white	Y_L		5.0	7.0	-	cd/m ²		
White Uniformity	δ_w		-	-	1.45		【Note5】	

※The measurement shall be executed 15-20 minutes after lighting at rating. The optical characteristics shall be measured in a dark room or equivalent state with the method shown in Fig.3 below. ($I_L=5.0\text{mArms}$)

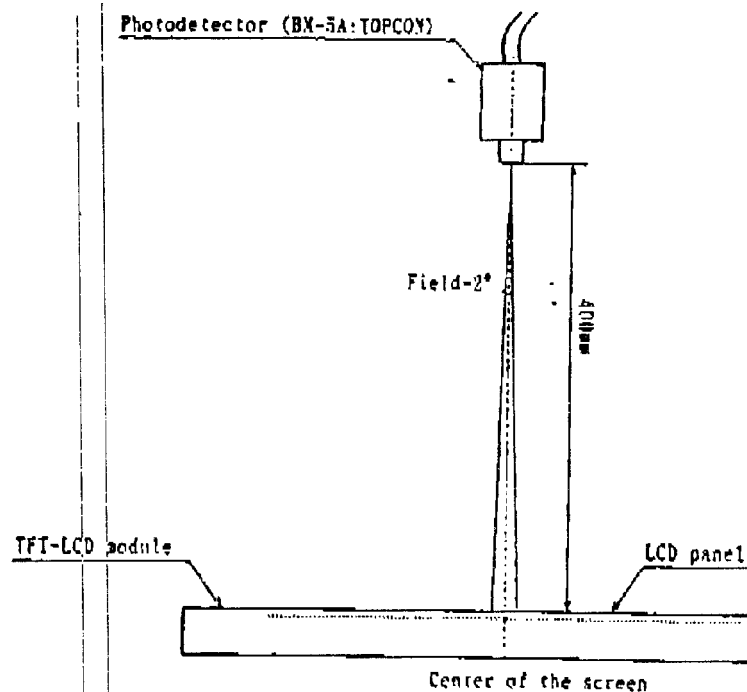
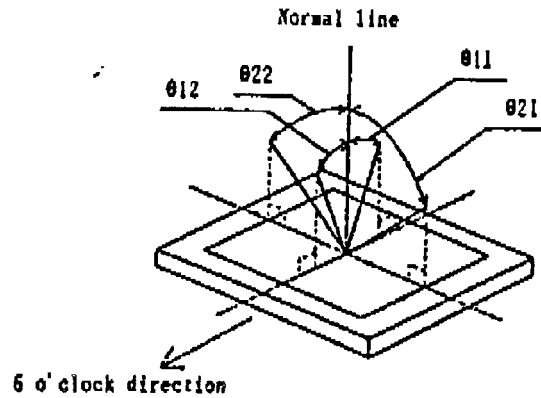

Fig.3 Optical characteristics measurement method

[Note1] Definitions of viewing angle range:



[Note2] Definition of Contrast Ratio:

The contrast ratio is defined as the following.

$$\text{Contrast Ratio} = \frac{\text{Luminance (brightness) with all pixels white}}{\text{Luminance (brightness) with all pixels black}}$$

[Note3] Definitions of Response Time:

The response time shall be measured like the following figure by switching the input signals for "black" ON and OFF.

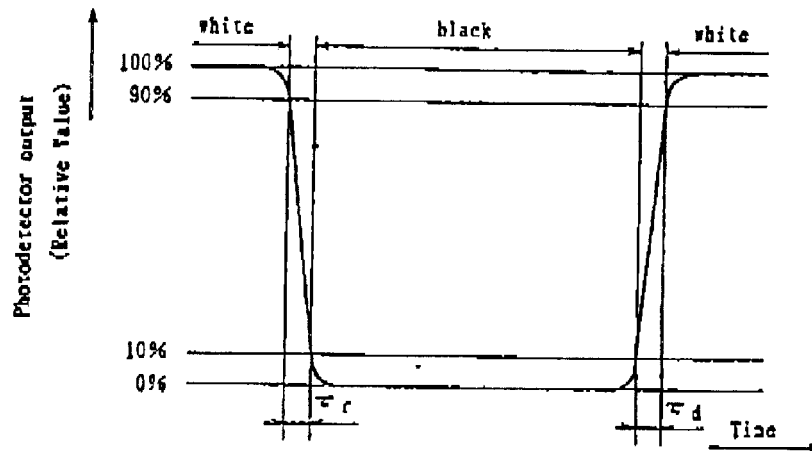

[Note4] They shall be measured at center of the screen.

[Note5] Definition of White Uniformity

White Uniformity is defined as the following with five measurements (A-E).

$$\frac{\text{Maximum Luminance (brightness)}}{\text{Minimum Luminance (brightness)}}$$

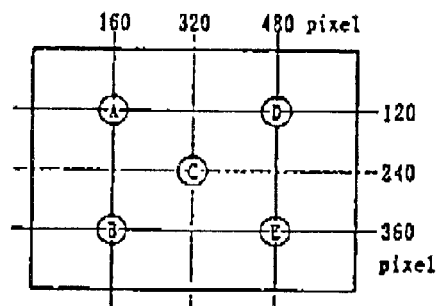

8. Display quality

The display quality of the color TFT-LCD module shall be in compliance with the Delivery Inspection Standard.

9. Handling Precautions

9-1) Be sure to insert the cable into the connector or take out of the connector after turning off the power supply on the set side.

9-2) Power ON/OFF sequential timing

To prevent the latch-up of the circuit in the module, keep the sequential timing between the input signals and supply voltage as follows.

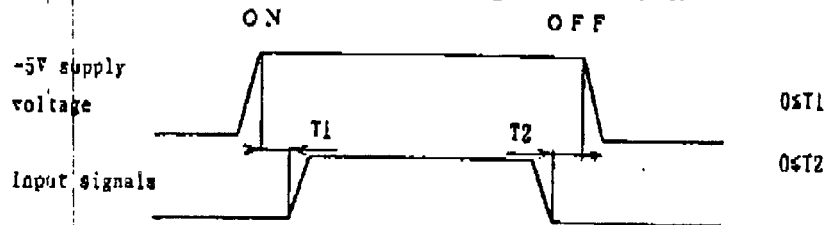

9-3) Others

- a) Laminated film is attached to the module surface to prevent it from being scratched. Peel the film off slowly, just before the use, with strict attention to electrostatic charges. Ionized air shall be blown over during the action. Blow off 'dust' on the polarizer by using an ionized nitrogen gun, etc.
- b) When installing the module, be sure to fix the module on the same plane, taking care not to warp or twist the module.
- c) Since the front polarizer is easily damaged, pay attention not to scratch it.
- d) Wipe off water drop immediately. Long contact with water may cause discoloration or spots.
- e) When the panel surface is soiled, wipe it with absorbent cotton or other soft cloth.
- f) Since the panel is made of glass, it may break or crack if dropped or bumped on hard surface. Handle with care.
- g) Since CMOS LSI is used in this module, take care of static electricity and ground your body when handling.
- h) Observe all other precautionary requirements in handling components.

10. Packing form

- a) Piling number of cartons : MAX. 7
- b) Package quantity in one carton : MAX. 10
- c) Carton size : 413(W) \times 288(H) \times 351(D)mm
- d) Total weight of 1 carton filled with full modules : 7000g

Packing form is shown in Fig. 4.

11. Reliability test items

No.	Test item	Conditions
1	High temperature storage test	Ta=60°C 240h
2	Low temperature storage test	Ta=-25°C 240h
3	High temperature & high humidity operation test	Ta=40°C;95%RH 240h (No condensation)
4	High temperature operation test	Ta=50°C 240h (The panel temp. must be less than 60°C)
5	Low temperature operation test	Ta=0°C 240h
6	Vibration test (non-operating)	Frequency:10-57Hz/Vibration width (one side):0.075mm :58-500Hz/Gravity:9.8m/s ² Sweep time: 11 minutes Test period: 3 hours (1 hour for each direction of X, Y, Z)
7	Shock test (non-operating)	Max. gravity: 490m/s ² Pulse width: 11ms, sine wave Direction: ±X, ±Y, ±Z once for each direction.

【Result Evaluation Criteria】

Under the display quality test conditions with normal operation state, these shall be no change which may affect practical display function.

12. Others

1) Lot No. Label

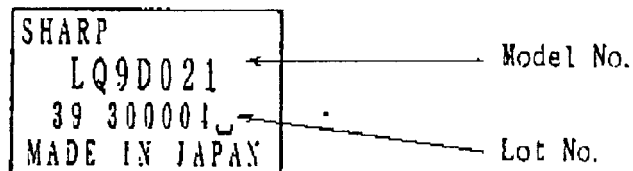

2) UL, CSA Label

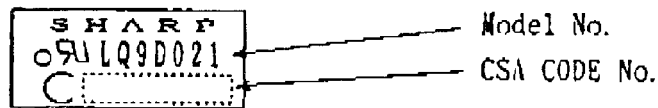

- 3) Adjusting volumes have been set optimally before shipment, so do not change any adjusted values. If adjusted values are changed, the data mentioned in this technical literature may not be satisfied.
- 4) Disassembling the module can cause permanent damage and should be strictly avoided.
- 5) Please be careful since image retention may occur when a fixed pattern is displayed for a long time.
- 6) If any problem occurs in relation to the description of this specification, it shall be resolved through discussion with spirit of cooperation.

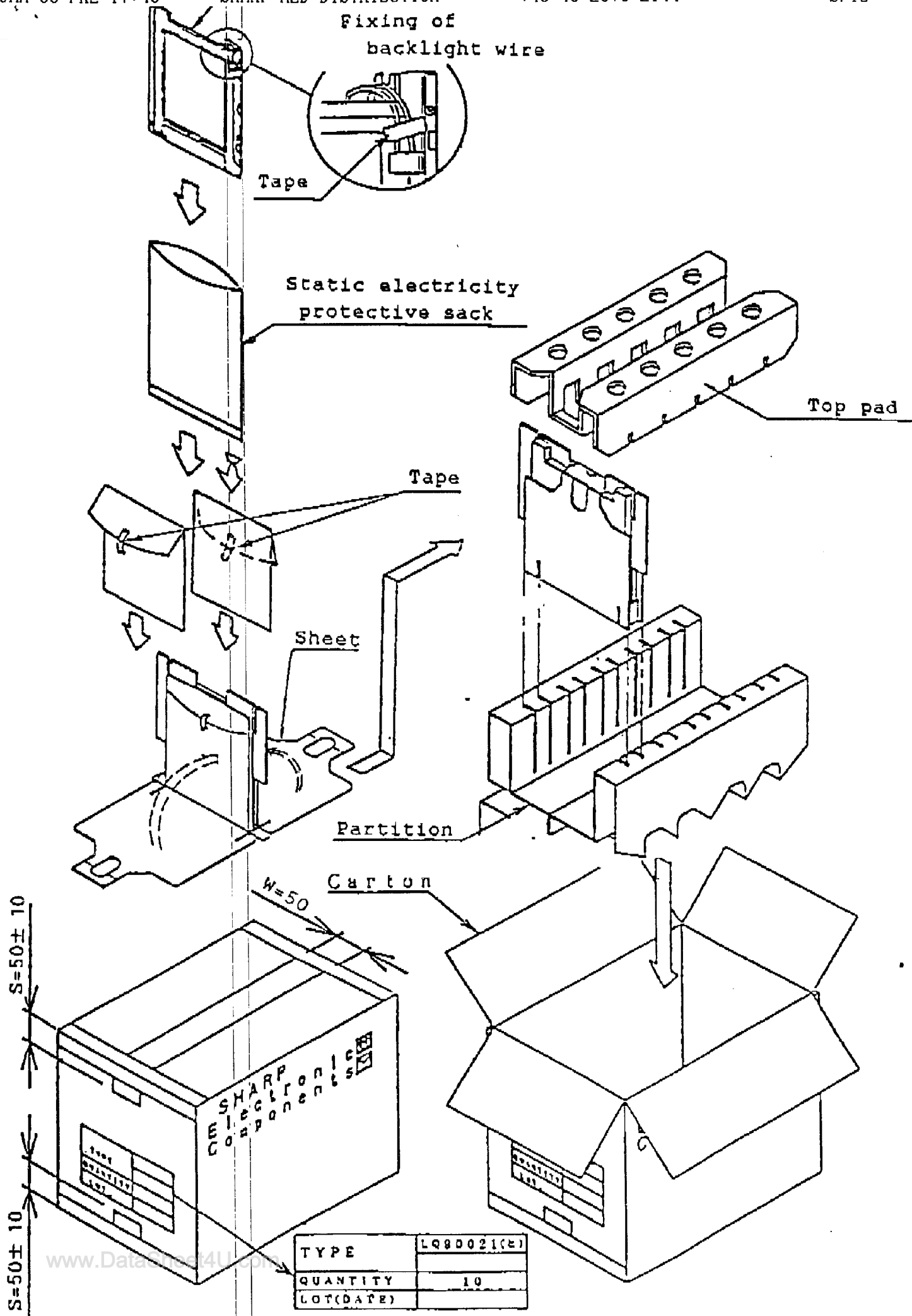
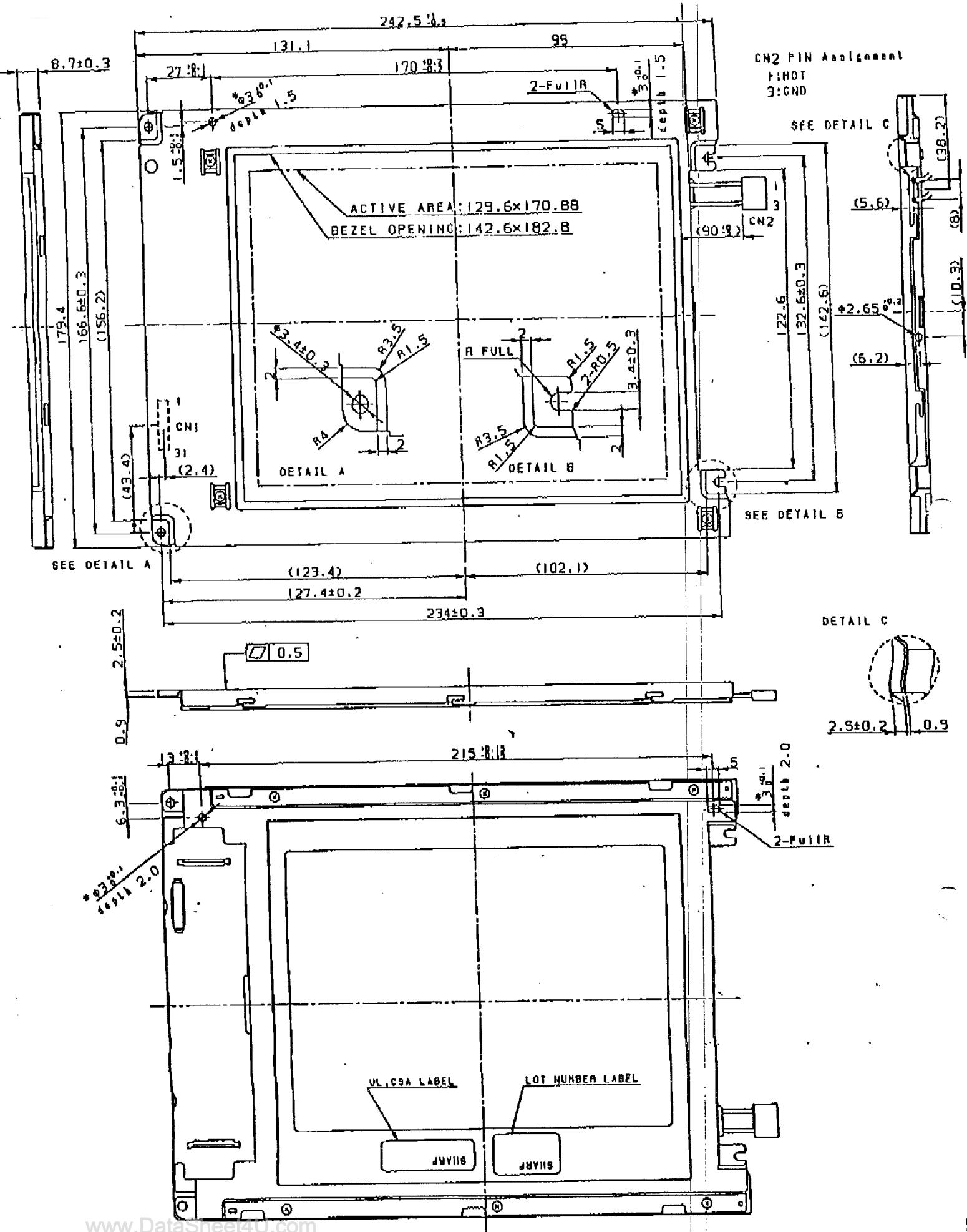

Fig.4 Packing form



General tolerance is ± 0.5
 Value in () is just for reference

These holes (Ø) can be used for aligning this module to your product.

Fig. 1 OUTLINE DIMENSIONS

7. SPECIFICATIONS

7-1. GENERAL SPECIFICATIONS

Item	Specifications	Unit
Module size	243.0±0.5 (H) × 185.1±0.5 (V) × 11.0 MAX. (D)	mm
Inverter size	25.0±0.5 (H) × 100.0 ±0.3 (V) × 10.2 MAX. (D)	mm
Display area	211.2 (H) × 158.4 (V)	mm
Number of pixels	640 (H) × 480 (V)	pixel
Dot pitch	0.11 (H) × 0.33 (V)	mm
Pixel pitch	0.33 (H) × 0.33 (V)	mm
Pixel arrangement	RGB (Red, Green, Blue) vertical stripe	-
Display colors	262,144	color
Weight	500 (MAX. included inverter) 20 (MAX. only inverter)	g

7-2. ABSOLUTE MAXIMUM RATINGS

Parameter	Symbol	Ratings	Unit	Remarks
Supply voltage	VCC	-0.3 to +6.5	V	Ta=25°C
Input voltage	VI	-0.3 to VCC + 0.3	V	
Storage temp.	Tst	-20 to +60	°C	-
Operation temp.	Top	0 to +50	°C	module surface *
Humidity	RH	≧ 95% relative humidity	Ta=40°C	no condensation
		≧ 85% relative humidity	Ta=50°C	
		Absolute humidity shall not exceed Ta=50°C, 85% relative humidity level.	Ta>50°C	

* measured at the display area

7-3. ELECTRICAL CHARACTERISTICS

(1) Logic, LCD driving

Ta = 25°C

Parameter	Symbol	Min.	Typ.	Max.	Unit	Remarks
Supply voltage #1)	VCC	3.0 (4.75)	3.3 (5.0)	3.6 (5.25)	V	VCC=3.3V (VCC=5.0V)
Logic input "L" voltage	VI(L)	0	-	VCC×0.3	V	—
Logic input "H" voltage	VI(H)	VCC×0.7	-	5.25	V	
Supply current	ICC	-	*2) 300 *2) (200)	400 (300)	mA	VCC=3.3V (VCC=5.0V)

*2): Checker flag pattern (in EIAJ ED-2522)

7. SPECIFICATIONS

7-1. GENERAL SPECIFICATIONS

Item	Specifications	Unit
Module size	243.0±0.5 (H) × 185.1±0.5 (V) × 11.0 MAX. (D)	mm
Inverter size	25.0±0.5 (H) × 100.0 ±0.3 (V) × 10.2 MAX. (D)	mm
Display area	211.2 (H) × 158.4 (V)	mm
Number of pixels	640 (H) × 480 (V)	pixel
Dot pitch	0.11 (H) × 0.33 (V)	mm
Pixel pitch	0.33 (H) × 0.33 (V)	mm
Pixel arrangement	RGB (Red, Green, Blue) vertical stripe	-
Display colors	262,144	color
Weight	500 (MAX. included inverter) 20 (MAX. only inverter)	g

7-2. ABSOLUTE MAXIMUM RATINGS

Parameter	Symbol	Ratings	Unit	Remarks
Supply voltage	VCC	-0.3 to +6.5	V	Ta=25°C
Input voltage	VI	-0.3 to VCC + 0.3	V	
Storage temp.	Tst	-20 to +60	°C	-
Operation temp.	Top	0 to +50	°C	module surface *
Humidity	RH	≧ 95% relative humidity	Ta=40°C	no condensation
		≧ 85% relative humidity	Ta=50°C	
		Absolute humidity shall not exceed Ta=50°C, 85% relative humidity level.	Ta>50°C	

* measured at the display area

7-3. ELECTRICAL CHARACTERISTICS

(1) Logic, LCD driving

Ta = 25°C

Parameter	Symbol	Min.	Typ.	Max.	Unit	Remarks
Supply voltage *1)	VCC	3.0 (4.75)	3.3 (5.0)	3.6 (5.25)	V	VCC=3.3V (VCC=5.0V)
Logic input "L" voltage	VIL	0	-	VCC×0.3	V	-
Logic input "H" voltage	VIH	VCC×0.7	-	5.25	V	-
Supply current	ICC	-	*2) 300 *2) (200)	400 (300)	mA	VCC=3.3V (VCC=5.0V)

*2): Checker flag pattern (in EIAJ ED-2522)