

General Description

The LR324 consists of four independent, high gain and internally frequency compensated operational amplifiers. It is specifically designed to operate from a single power supply. Operation from split power supply is also possible and the low power supply current drain is independent of the magnitude of the power supply voltages.

Package

- Package of LR324 is DIP-14
- Package of LR324D is SOP-14

Features

- Internally Frequency Compensated
- Large Voltage Gain
- Low Input Bias Current
- Low Input Offset Voltage
- Large Output Voltage Swing
- Wide Power Supply Voltage Range:
Single Supply 3V to 30V or
Dual Supplies $\pm 1.5V$ to $\pm 15V$
- Low Supply Current Drain: $600\mu A$

Applications

- Battery Charger
- Cordless Telephone
- Switching Power Supply



Pin Configuration

Package/Package
(DIP-14/SOP-14)

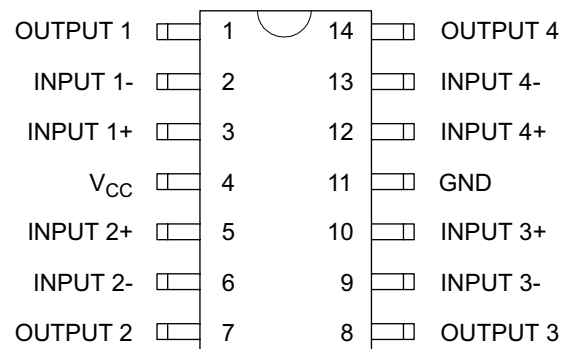

Top View

Figure 1. Pin Configuration of LR324/LR324D

LR324

Functional Block Diagram

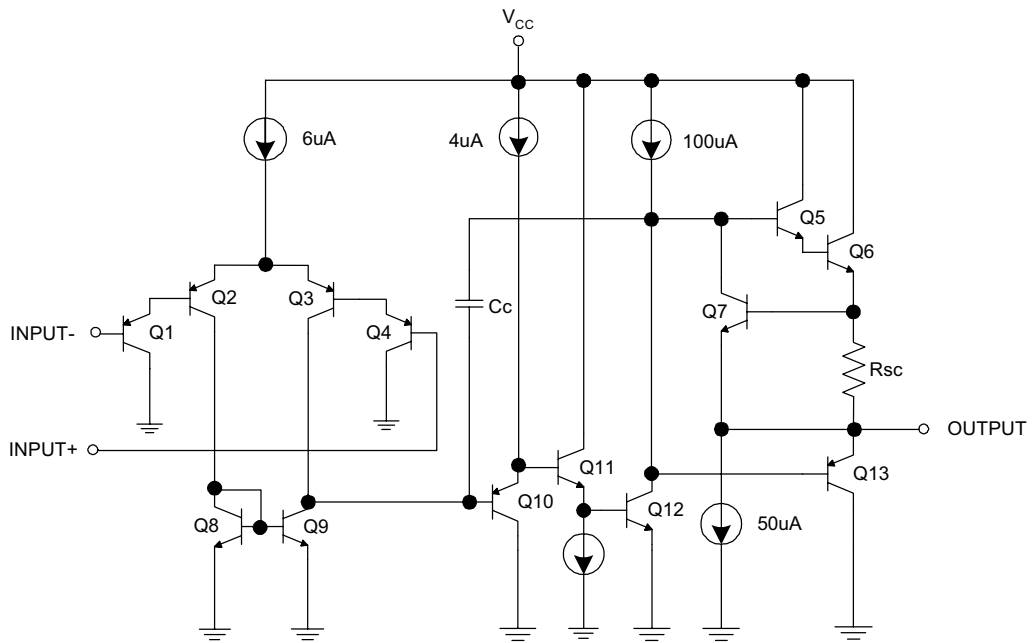

Figure 2. Functional Block Diagram of LR324/LR324D
(Each Amplifier)

LR324

Ordering Information

Package	Temperature Range	Part Number	Packing Type
DIP-14	-40 to 85°C	LR324	Tube
SOP-14		LR324D	Tube

Absolute Maximum Ratings

Parameter	Symbol	Value	Unit
Power Supply Voltage	V_{CC}	32	V
Differential Input Voltage	V_{ID}	32	V
Input Voltage	V_{IC}	-0.3 to 32	V
Output Short Circuit to Ground (One Amplifier) $V_{CC} \leq 12V$ and $T_A = 25^\circ C$		Continuous	
Power Dissipation	P_D	720	mW
Operating Temperature Range	T_{OP}	-30 to 85	°C
Storage Temperature Range	T_{STG}	-55 to 125	°C

LR324

Electrical Characteristics

$V_{CC}=+5V$, $GND=0V$, $T_A=25\text{ }^\circ\text{C}$ unless otherwise specified.

Parameter	Symbol	Test Conditions	Min	Typ	Max	Unit	
Input Offset Voltage	V_{IO}	$V_O: 1.4V$, $R_S: 0\Omega$, V_{CC} : from 5V to 15V		2	7	mV	
Input Bias Current	I_{BIAS}	I_{IN^+} or I_{IN^-} , $V_{CM}=0V$		45	250	nA	
Input Offset Current	I_{IO}	I_{IN^+} or I_{IN^-} , $V_{CM}=0V$		5	50	nA	
Input Common Mode Voltage Range	V_{IR}	$V_{CC}=15V$	0		$V_{CC}-1.5$	V	
Supply Current	I_{CC}	$R_L = \infty$, Over full temperature range on all OP Amps		0.6	2	mA	
		$V_{CC}=30V$		1.5	3		
Large Signal Voltage Gain	G_V	$V_{CC}=15V$, $R_L \geq 2K\Omega$, $V_O=1V$ to 11V	25	100		dB	
Common Mode Rejection Ratio	CMRR	DC, $V_{CC}=15V$, $V_{CM}=0V$ to $(V_{CC}-1.5)V$	65	80		dB	
Power Supply Rejection Ratio	PSRR	$V_{CC}=5V$ to 15V	65	100		dB	
Channel Separation (Note 6)	CS	$f=1KHz$ to 20KHz (Input Referred)		120		dB	
Output Current	Source	I_{SOURCE}	$V_+=1V$, $V_-=0V$, $V_{CC}=15V$, $V_O=2V$	20	40		mA
	Sink	I_{SINK}	$V_-=1V$, $V_+=0V$, $V_{CC}=15V$, $V_O=2V$	10	20		mA

LR324

Typical Performance Characteristics

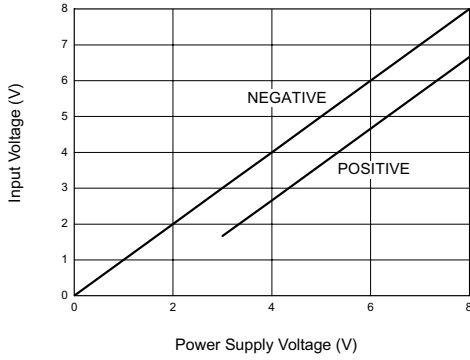

Figure 3. Input Voltage Range

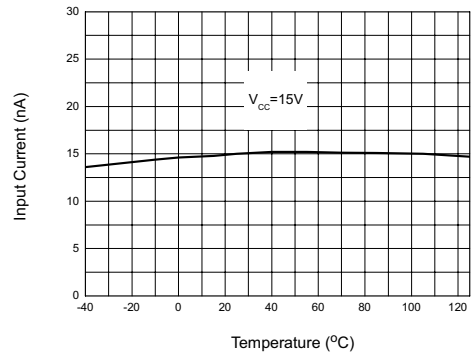

Figure 4. Input Current

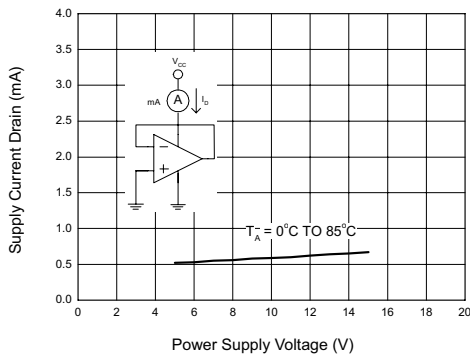

Figure 5. Supply Current

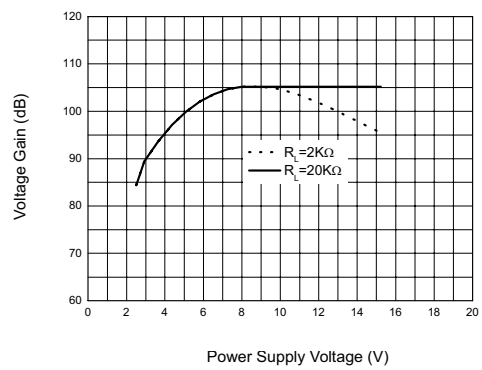

Figure 6. Voltage Gain

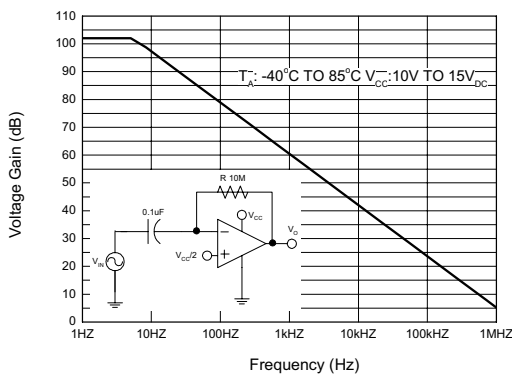

Figure 7. Open Loop Frequency Response

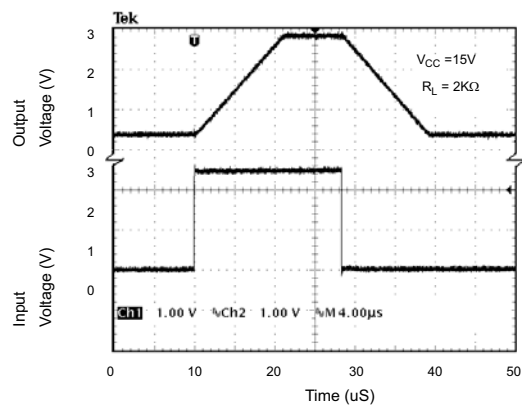

Figure 8. Voltage Follower Pulse Response

LR324

Typical Performance Characteristics (Continued)

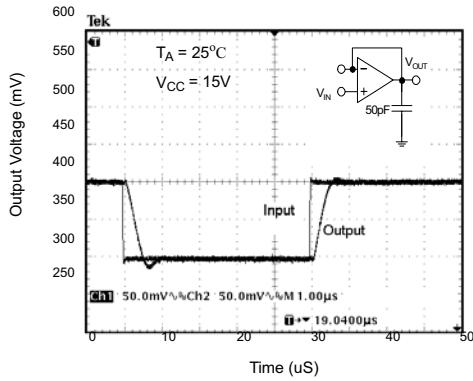

Figure 9. Voltage Follower Pulse Response (Small Signal)

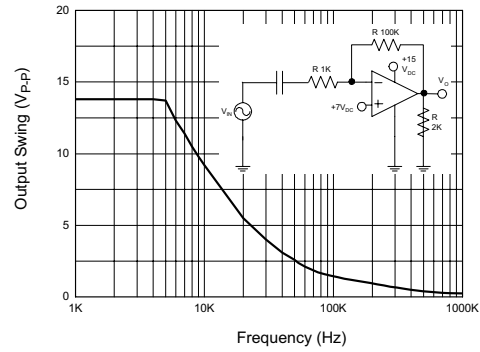

Figure 10. Large Signal Frequency Response

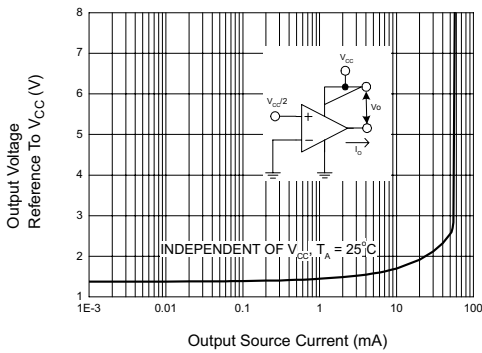

Figure 11. Output Characteristics Current Sourcing

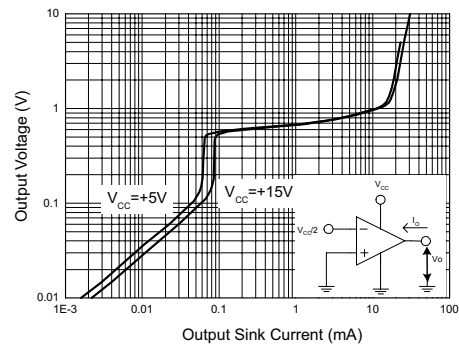

Figure 12. Output Characteristics Current Sinking

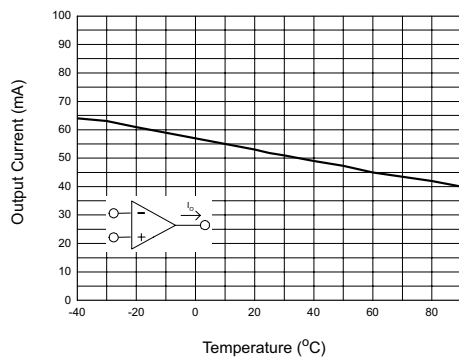

Figure 13. Current Limiting

LR324

Typical Applications

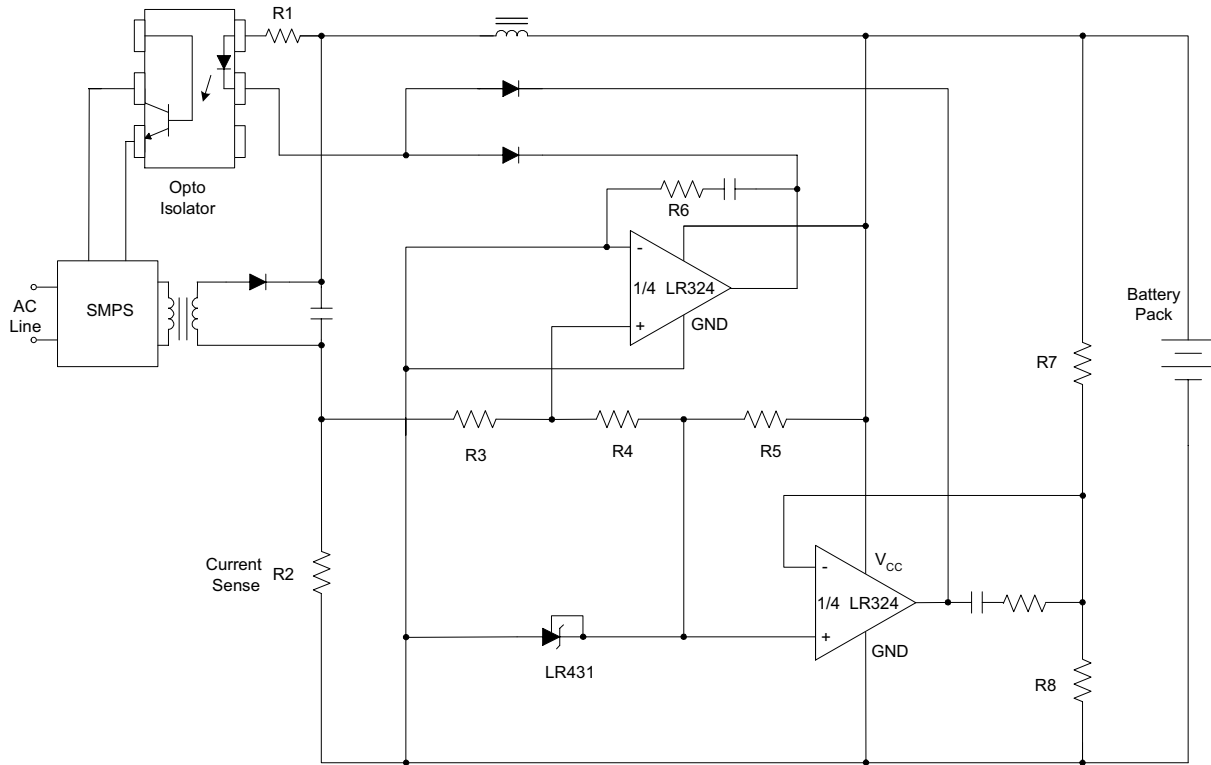

Figure 14. Battery Charger

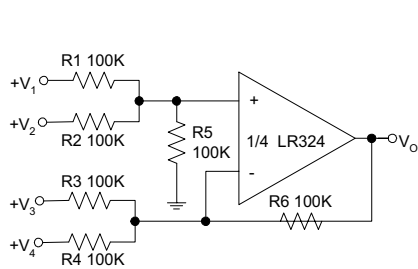

Figure 15. DC Summing Amplifier

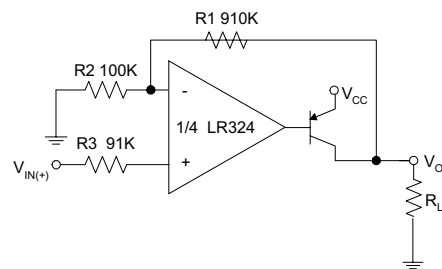

Figure 16. Power Amplifier

LR324

Typical Applications (Continued)

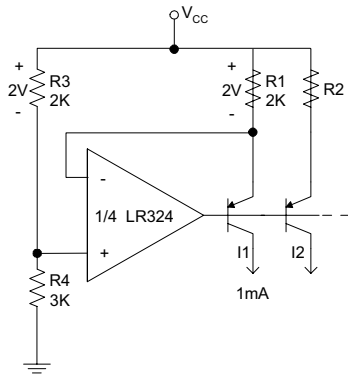

Figure 17. Fixed Current Sources

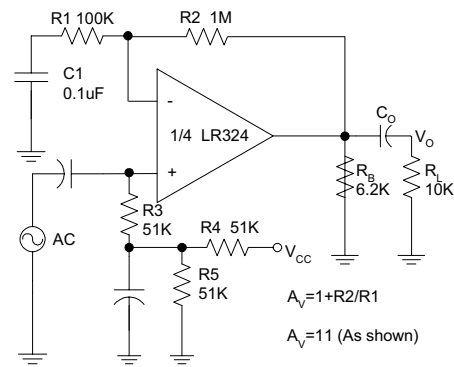

Figure 18. AC Coupled Non-Inverting Amplifier

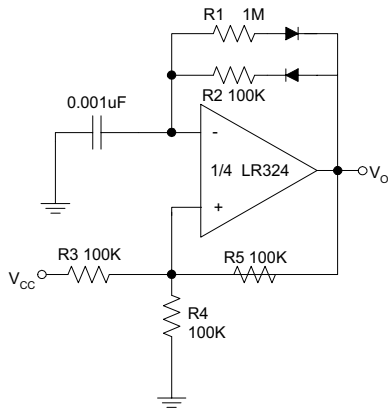

Figure 19. Pulse Generator

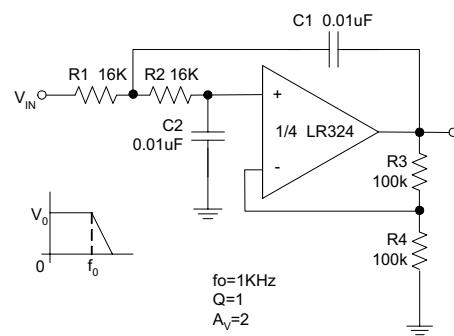

Figure 20. DC Coupled Low-Pass RC Active Filter

LR324

Mechanical Dimensions

DIP-14

Unit: mm

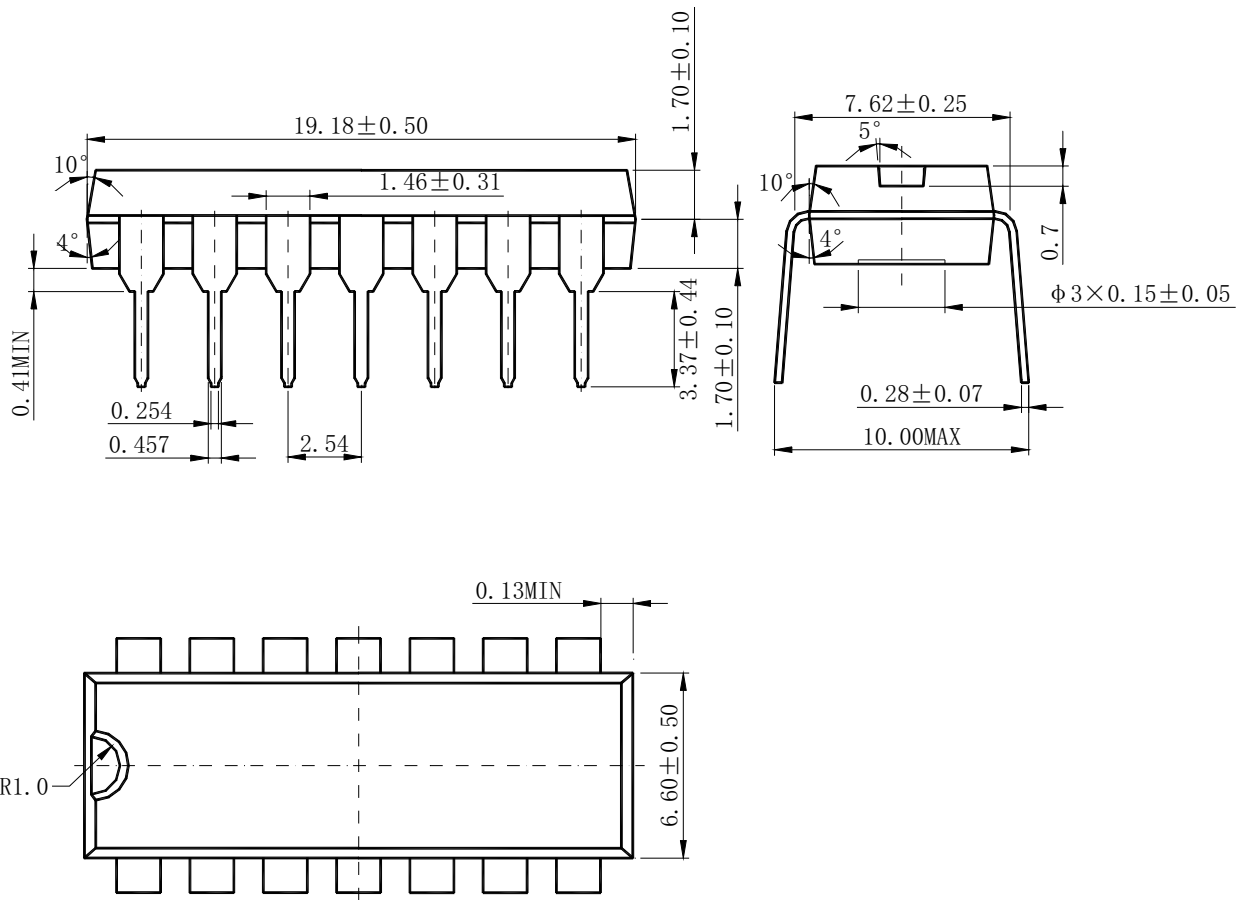

LR324

Mechanical Dimensions (Continued)

SOP-14

Unit: mm

