

LR431 LINEAR INTEGRATED CIRCUIT

PROGRAMMABLE PRECISION REFERENCE

DESCRIPTION

The LRC LR431 is a three-terminal adjustable regulator with a guaranteed thermal stability over applicable temperature ranges. The output voltage may be set to any value between V_{ref} (approximately 2.5V) and 36V with two external resistors. It provides very wide applications, including shunt regulator, series regulator, switching regulator, voltage reference and others.

FEATURES

Programmable output Voltage to 36V.

Low dynamic output impedance 0.2Ω

Sink current capability of 1 to 100mA.

Equivalent full-range temperature coefficient of $50\text{ppm}/^\circ\text{C}$ typical for operation over full rated operating temperature range.

We declare that the material of product compliance with RoHS requirements.

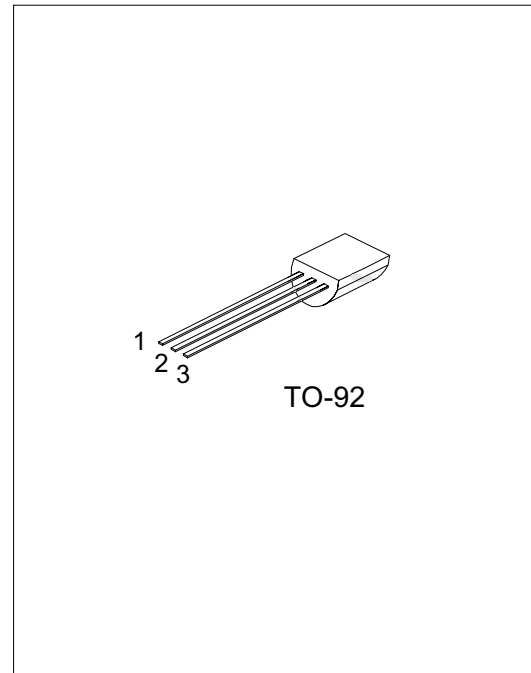

TO-92 1: Ref ; 2: Anode; 3: Cathode

BLOCK DIAGRAM

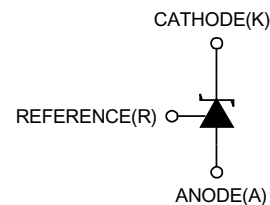
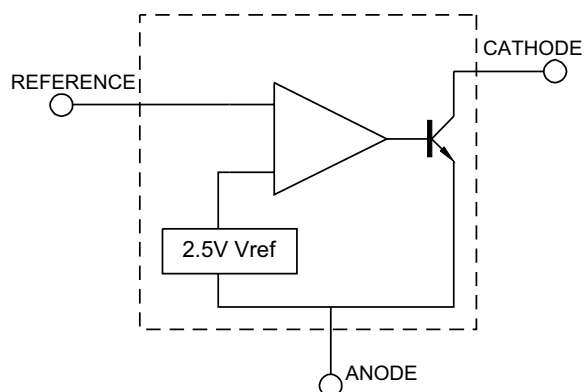

LR431 LINEAR INTEGRATED CIRCUIT

ABSOLUTE MAXIMUM RATINGS (Operating temperature range applies unless otherwise specified)

PARAMETER	SYMBOL	VALUE	UNIT
Cathode Voltage	V _{KA}	37	V
Cathode Current Range(Continuous)	I _{KA}	-100 ~ +150	mA
Reference Input Current Range	I _{ref}	-0.05 ~ +10	mA
Operating Junction Temperature	T _j	150	°C
Operating Ambient Temperature	T _{opr}	-40 ~ +70	°C
Storage Temperature Temperature	T _{stg}	-65 ~ +150	°C

RECOMMENDED OPERATING CONDITIONS

PARAMETER	SYMBOL	MIN	TYP	MAX	UNIT
Cathode Voltage	V _{KA}	V _{REF}		36	V
Cathode Current	I _{KA}	1		100	mA

ELECTRICAL CHARACTERISTICS (T_a=25°C, unless otherwise specified)

PARAMETER	SYMBOL	TEST CONDITIONS	MIN	TYP	MAX	UNIT
Reference Input Voltage	V _{ref}	V _{KA} =V _{REF} , I _{KA} =10mA		2.50		V
Deviation of reference Input Voltage Over temperature(note 1)	ΔV _{ref} /ΔT	V _{KA} =V _{REF} , I _{KA} =10mA T _{MIN} ≤T _A ≤T _{MAX}		4.5	17	mV
Ratio of Change in Reference Input Voltage to the Change in Cathode Voltage	ΔV _{ref} / ΔV _{KA}	I _{KA} =10mA ΔV _{KA} =10V~V _{REF} ΔV _{KA} =36V~10V		-1.0 -0.5	-2.7 -2.0	mV/V
Reference Input Current	I _{ref}	I _{KA} =10mA, R ₁ =10kΩ, R ₂ =∞		1.5	4	μA
Deviation of Reference Input Current Over Full Temperature Range	ΔI _{ref} /ΔT	I _{KA} =10mA, R ₁ =10kΩ, R ₂ =∞ T _A =full Temperature		0.4	1.2	μA
Minimum Cathode Current for Regulation	I _{KA} (min)	V _{KA} =V _{REF}		0.45	1.0	mA
Off-State Cathode Current	I _{KA} (OFF)	V _{KA} =36V, V _{REF} =0		0.05	1.0	μA
Dynamic Impedance	Z _{KA}	V _{KA} =V _{REF} , I _{KA} =1 to 100mA f≤1.0kHz		0.15	0.5	Ω

Note: T_{MIN}=0°C, T_{MAX}=+70°C

CLASSIFICATION OF V_{ref} AND PACKAGE

Device	LR431A	LR431B
Rank	0.5%	1%
Range(V)	2.487~2.512	2.475~2.525
Marking	LR431A	LR431B
Package	TO-92	TO-92

LR431 LINEAR INTEGRATED CIRCUIT

TYPICAL PERFORMANCE CHARACTERISTICS

Fig 1 Cathode Current Vs Cathode Voltage

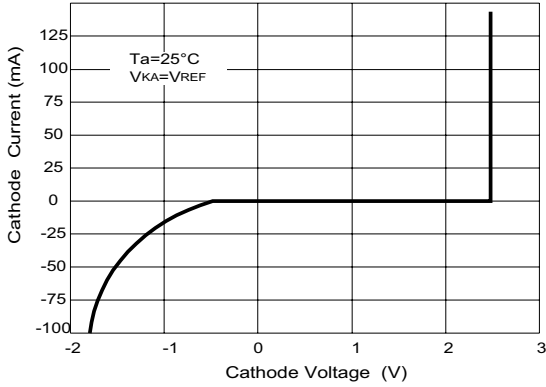

Fig 2 Cathode Current Vs Cathode Voltage

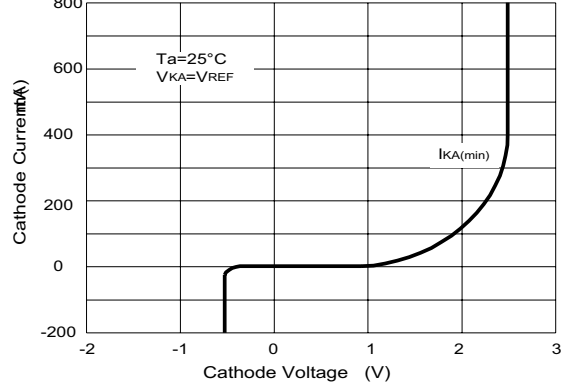

Fig 3 Change in Reference Input Voltage Vs Cathode voltage

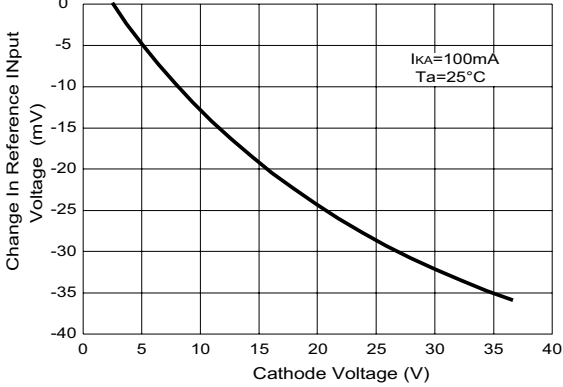

Fig 4 Pulse Response

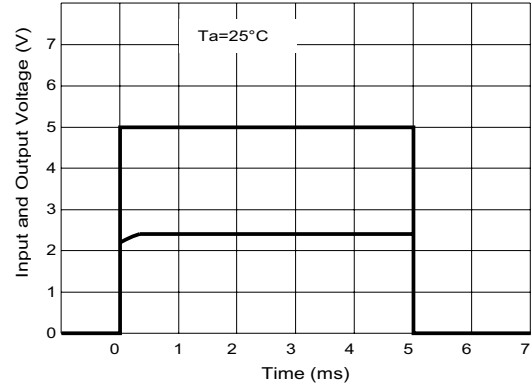

Fig 5 Dynamic Impedance Vs Frequency

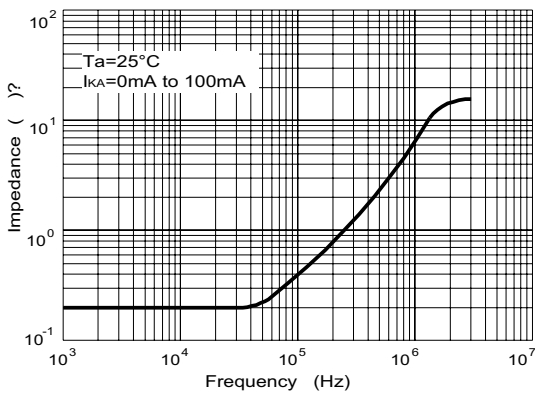
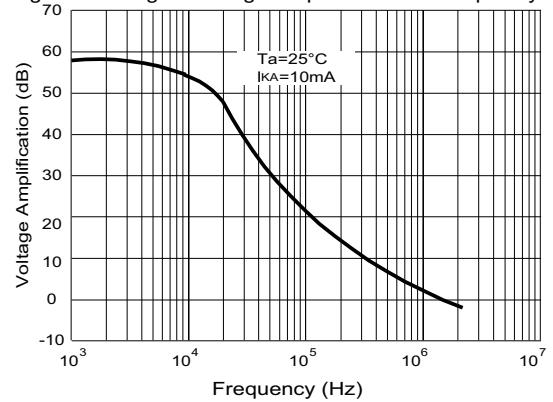

Fig 6 Small Signal Voltage Amplification Vs Frequency



LR431 LINEAR INTEGRATED CIRCUIT

TEST CIRCUIT

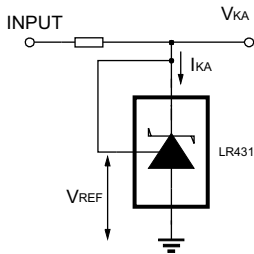

Fig 7 Test Circuit For $V_{KA}=V_{REF}$

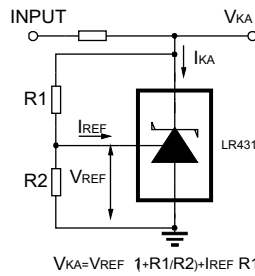

Fig 8 Test Circuit for $V_{KA} \geq V_{REF}$

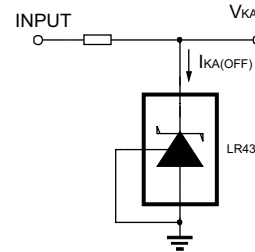

Fig 9 Test Circuit For $I_{KA(OFF)}$

APPLICATION CIRCUIT

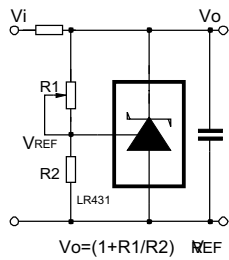

Fig 10 Shutdown Regulator

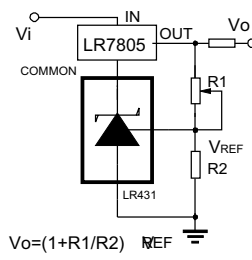

Fig 11 Output Control of a Three-Terminal Fixed Regulator

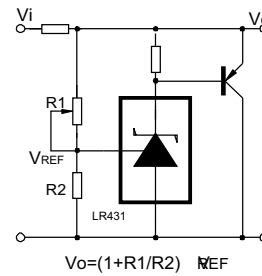

Fig 12 Higher-current Shunt Regulator

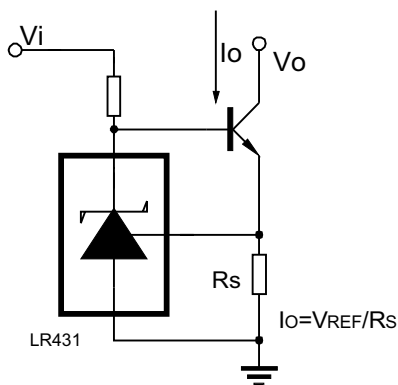

Fig 13 Constant-current Sink

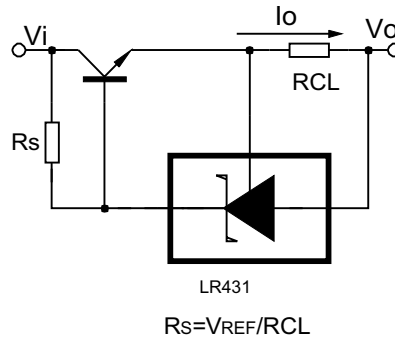
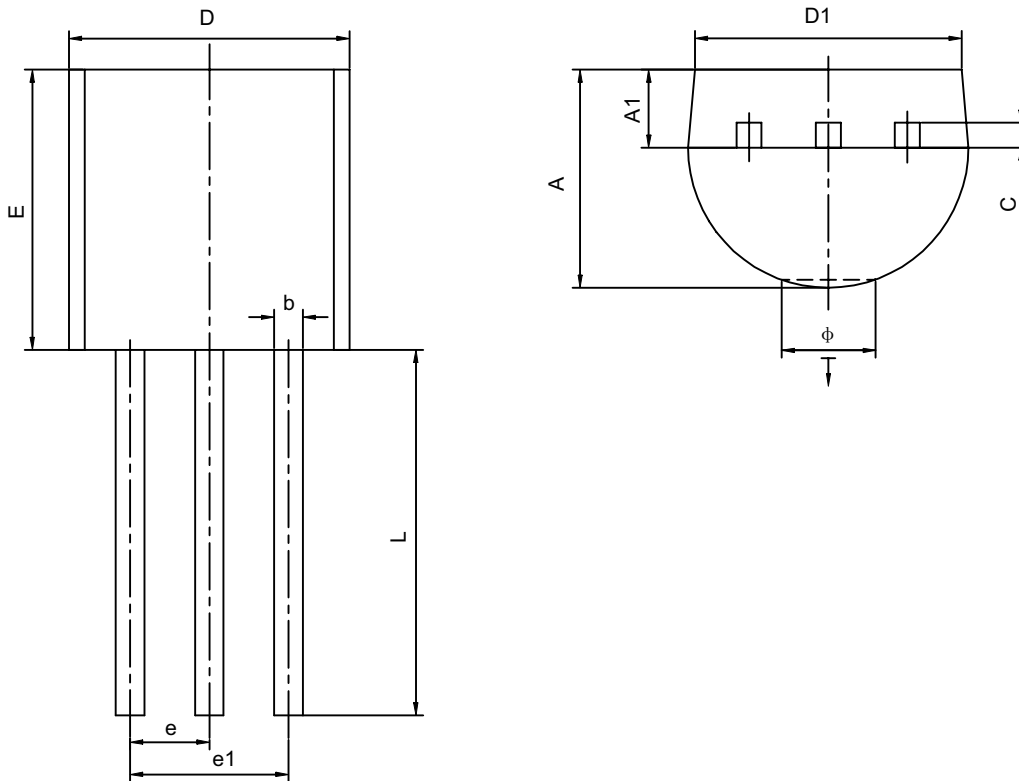

Fig 14 Current Limiting or Current Source

TO-92 PACKAGE OUTLINE DIMENSIONS

Symbol	Dimensions In Millimeters		Dimensions In Inches	
	Min	Max	Min	Max
A	3.300	3.700	0.130	0.146
A1	1.100	1.400	0.043	0.055
b	0.380	0.550	0.015	0.022
c	0.360	0.510	0.014	0.020
D	4.400	4.700	0.173	0.185
D1	3.430		0.135	
E	4.300	4.700	0.169	0.185
e	1.270TYP		0.050TYP	
e1	2.440	2.640	0.096	0.104
L	14.100	14.500	0.555	0.571
φ		1.600		0.063
T	0.000	0.380	0.000	0.015