

LIQUID CRYSTAL DISPLAY MODULE

Product Specification

PRODUCT NUMBER	LR4422
-----------------------	---------------

INTERNAL APPROVALS		
Product Manager	Engineering	Document Control

TABLE OF CONTENTS

1	MAIN FEATURES	4
2	MECHANICAL DRAWING	5
3	ABSOLUTE MAXIMUM RATINGS	6
4	ELECTRONICAL CHARACTERISTICS	6
5	OPTICAL CHARACTERISTICS	6
6	BACKLIGHT CHARACTERISTICS	9
7	OPERATING INSTRUCTIONS	10
7.1	<i>I/O PIN FUNCTION</i>	10
7.2	<i>AC CHARACTERISTICS</i>	11
7.3	<i>CHARACTER FONT</i>	13
8	BLOCK DIAGRAM.....	14
9	POWER SUPPLY	14
10	RELIABILITY TEST	15
10.1	<i>RELIABILITY NORMAL TEMPERATURE</i>	15
10.2	<i>RELIABILITY WIDE TEMPERATURE</i>	15
11	STANDARD OF APPEARANCE INSPECTION	16
12	PART NUMBER DESCRIPTION	18
13	HANDLING PRECAUTIONS	19

REVISION RECORD

Rev.	Date	Page	Par.	Comment	ECN no.
A	03/19/08	--	--	Initial DCA Release	E3662
B	4/9/14	4	--	Controller changed to ST7066U	E4949

1 MAIN FEATURES

ITEM	CONTENTS	UNIT
Outline Dimension	85.0 (W) x 36.0 (H) x 14.4 (D)	mm
Display Format	16 characters x 2 lines	dot
Active Area	56.2 (W) x 11.5 (H)	mm
Viewing Area	60.0 (W) x 15.8 (H)	mm
Character Dimensions	2.95 x 5.55	mm
Character Pitch	3.55 x 5.95	mm
Backlight Type	Array LED	--
Backlight Color	Yellow - Green	--
View Angle	6:00	O'clock
Duty Ratio	1/16	Duty
Bias	1/5	Bias
Controller	ST7066U	--
Driver	Sitronix ST7065	--
Power Supply	Vdd = (+5)	Volt
RoHS Complaint	Yes	-

2 MECHANICAL DRAWING

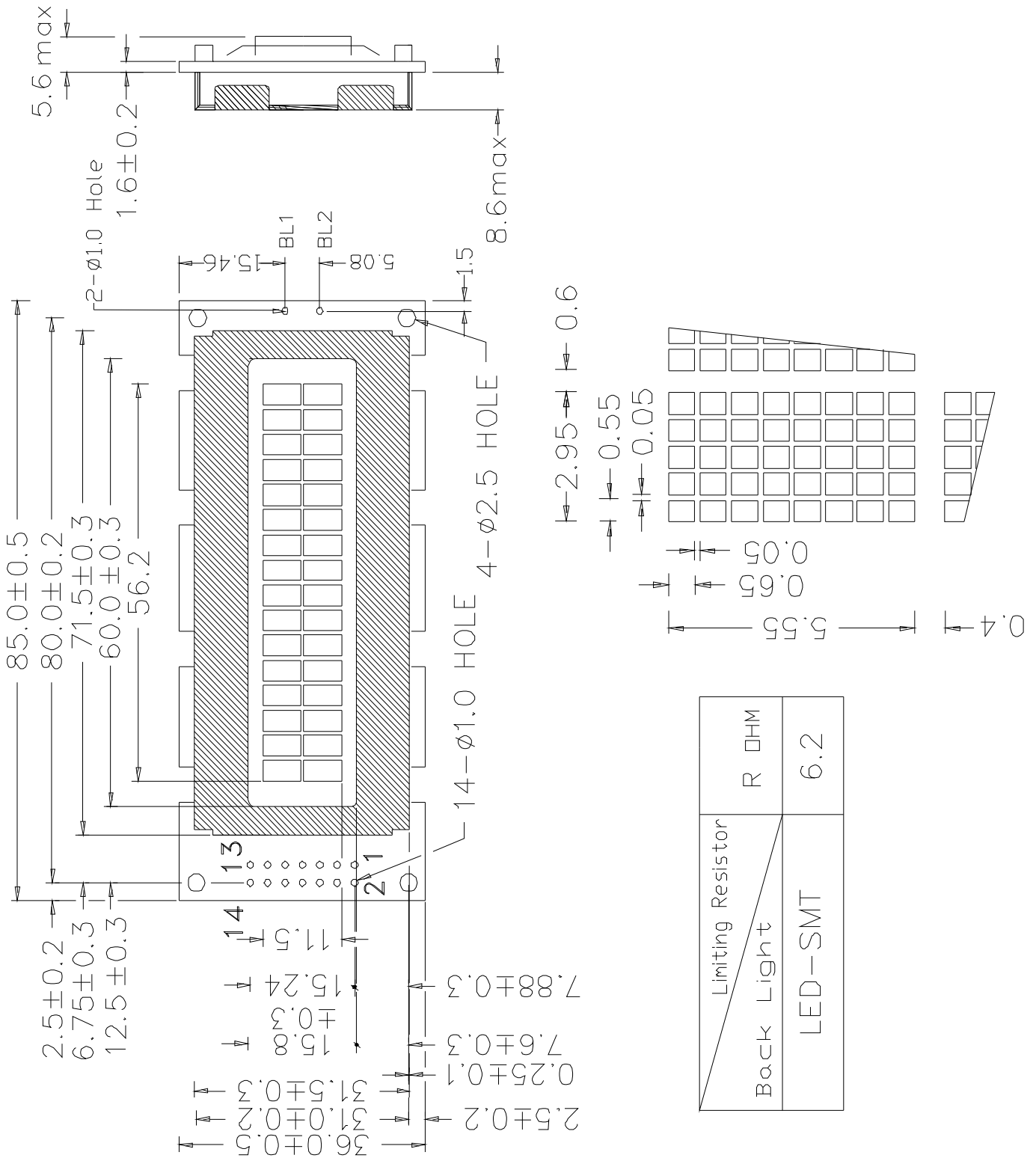

Limiting Resistor	R OHM	6.2
Back Light	LED-SMT	

Product No.	LR4422	REV. B
-------------	--------	--------

Page	5 / 19
------	--------

3 ABSOLUTE MAXIMUM RATINGS

(Ta=25°C, VSS=0V)

Item	Symbol	Conditions	Min	Typ	Unit
Power Supply Voltage	V _{DD}	Ta = 25°C ,50±10% RH	0	7.0	V
Operating Temperature	Topr	<65% (Normal Temp.)	0	50	°C
		<65% (Wide Temp.)	-20	70	
Storage Temperature	Tstg	<65% (Normal Temp.)	-20	70	°C
		<65% (Wide Temp.)	-30	80	
		<48 hrs	20	90	%RH
		<1000 hrs	20	65	%RH

4 ELECTRICAL CHARACTERISTICS

(Vss = 0V, Ta =25°C)

Item	Symbol	Condition	Min	Typ	Max	Unit
Operating Voltage	V _{DD}	-	4.75	--	5.25	V
Input Voltage	V _{ILC}	Low	0	--	0.55	V
	V _{IHC}	High	0.7 V _{DD}	--	V _{DD}	
LCD Driving Voltage	V _{DD} - V _O	--	3.0	V	10.0	V

5 LCD CURRENT CONSUMPTION & DRIVING VOLTAGE

V_{dd} - V_{ss} = 5.0V

		STN TEMPERATURE	
		NORMAL	WIDE
Supply Current , (I _{dd}) Typ. ,mA		1	1
Supply Current , (I _{ee}) Typ. ,mA		N/A	N/A
Supply voltage(V _{ee}) Max.		N/A	N/A
Recommend lcd drive voltage			
Lcd driving voltage (V _{dd} - V _o)	Ta = -20 °C	N/A	7.8
	Ta = 0 °C	4.8	7.3
	Ta = 25 °C	4.2	7.0
	Ta = 50 °C	3.9	6.5
	Ta = 70 °C	N/A	6.1

6 OPTICAL CHARACTERISTICS

Ta = 25°C

Item	Symbol	Condition	Min	Typ	Max	Unit	Note
Viewing Angle	Θ1 (down)	CR≥2	--	40	--	deg	5.1
	Θ2 (up)	CR≥2	--	30	--	deg	5.1
	Θ3 (right)	CR≥2	--	30	--	deg	5.2
	Θ4 (left)	CR≥2	--	30	--	deg	5.2
Contrast Ratio	Cr	Ta = 25°C	2	4	--	--	5.3
Response Time	Tr	Ta = 25°C	--	120	250	ms	5.4
	Tf	Ta = 25°C	--	160	300		
Driving Method	Duty	1/16					
	Bias	1/5					
Viewing Direction	6:00 O'clock						

Note 5.1: Definition of viewing angle θ_1 & θ_2

Note 5.2: Definition of viewing angle θ_3 & θ_4

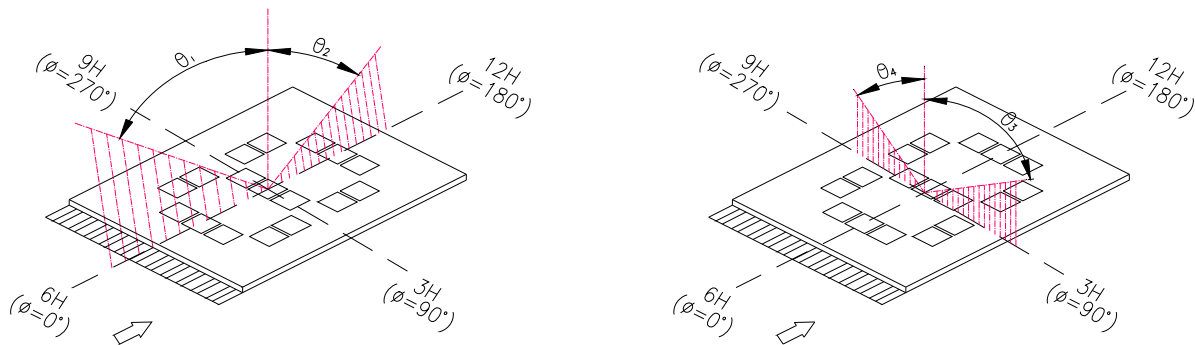

Note 5.3: Definition of contrast ratio (CR)

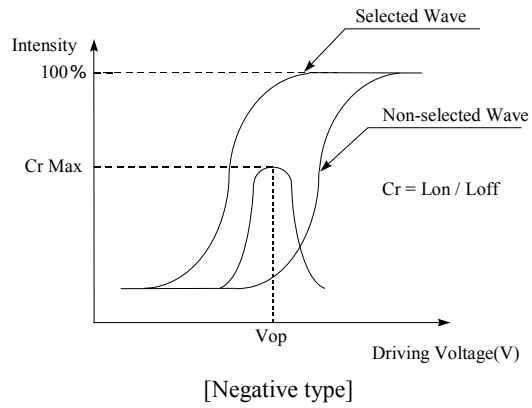
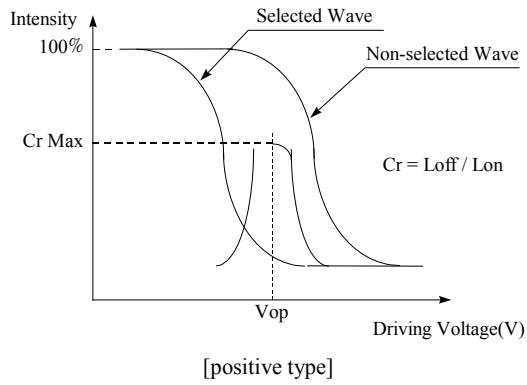

Note 5.4: Definition of response time

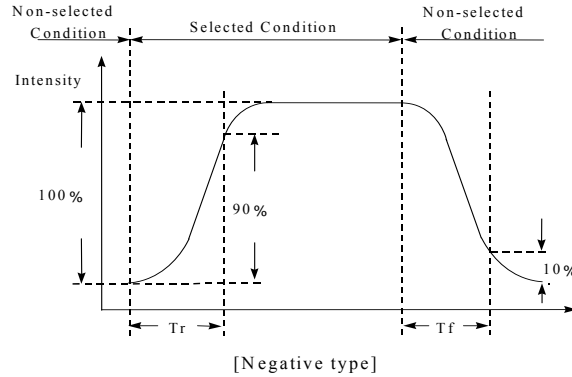
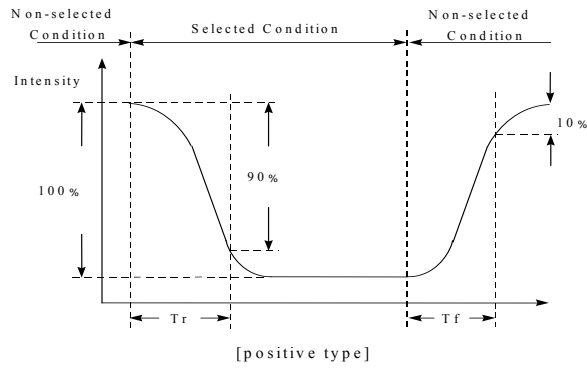

7 BACKLIGHT CHARACTERISTICS

Item	Conditions	Min	Typ	Max	Unit
Input Voltage	Ta = 25°C	--	5.0	--	V(DC)
Current Consumption	Ta = 25°C	--	120	--	mA
Average brightness (B/L only) (Ta=25°C, IL=120mA)	Test when connecting after 3 min. Ta = 25 C (max. contrast)				cd/m ² (note 2)
	Yellow-Green B/L	120	150	--	
Brightness Uniformity	Ta = 25°C , IL = 120 mA	80	--	--	% (note 3)
Lamp Life	Ta = 25°C , IL = 120 mA Humidity: 30%RH~85%RH	--	50,000	--	Hrs (note 4)
Operating Temp.	Humidity: 30%RH~85%RH	-20	--	70	°C
Storage Temp.	Humidity: 30%RH~85%RH	-30	--	80	°C
Limit Resistor (R1)	Ta = 25°C	--	6.2	--	OHM (note 1)

Note 1: R1:Built-in BL current limit resistor On LCDM .

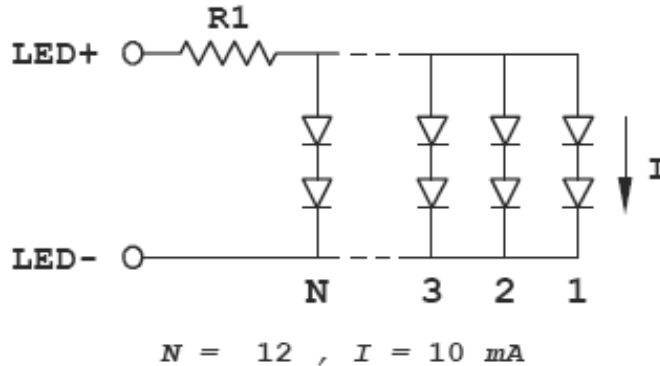

Note 2: Average brightness of 3 points when B/L is used at the beginning.

Note 3: Brightness uniformity = (MIN / MAX) x 100 %.

Note 4: Half of the original average brightness.

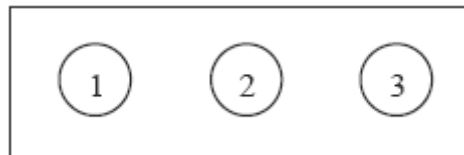

8 OPERATING INSTRUCTIONS

8.1 I/O PIN FUNCTION

Pin No.	Function	Level	Description
1	V _{ss} / LED(-)	--	Ground (0V) / Cathode of LED B/L
2	V _{dd}	--	Logic Supply Voltage (+5V)
3	V _o	--	Voltage Level for LCD Control Adjustment
4	RS	I	Register Select 0: Instruction Register 1: Data Register
5	R/W	I	Read / Write 0: Data Write (Module-MPU) 1: Data Read (Module-MPU)
6	E	I	Enable Signal Active High (H - L)
7 ~ 14	DB0 ~ DB7	I/O	Bi-directional data bus line 0 ~ 7
BL1	LED (+)	--	Anode of LED B/L
BL2	LED (-)	--	Cathode of LED B/L

8.2 AC CHARACTERISTICS

(Vdd = 2.7 ~ 5.5 V, Ta = -30°C ~ +85°C)

Symbol	Characteristics	Test Condition	Min	Typ	Max	Unit
Internal Clock Operation						
f _{OSC}	OSC Frequency	R = 91KΩ	190	270	350	KHz
External Clock Operation						
f _{EX}	External Frequency	--	125	270	410	KHz
--	Duty Cycle	--	45	50	55	%
T _R , T _F	Rise / Fall Time	--	--	--	0.2	μs
Write Mode (Writing data from MPU to ST7066U)						
T _C	Enable Cycle Time	Pin E	1200	--	--	ns
T _{PW}	Enable Pulse Width	Pin E	140	--	--	ns
T _R , T _F	Enable Rise / Fall Time	Pin E	--	--	25	ns
T _{AS}	Address Setup Time	Pins: RS, RW, E	0	--	--	ns
T _{AH}	Address Hold Time	Pins: RS, RW, E	10	--	--	ns
T _{DSW}	Data Setup Time	Pins: DB0 – DB7	40	--	--	ns
T _H	Data Hold Time	Pins: DB0 – DB7	10	--	--	ns
Read Mode (Reading data from ST7066U to MPU)						
T _C	Enable Cycle Time	Pin E	1200	--	--	ns
T _{PW}	Enable Pulse Width	Pin E	140	--	--	ns
T _R , T _F	Enable Rise / Fall Time	Pin E	--	--	25	ns
T _{AS}	Address Setup Time	Pins: RS, RW, E	0	--	--	ns
T _{AH}	Address Hold Time	Pins: RS, RW, E	10	--	--	ns
T _{DDR}	Data Setup Time	Pins: DB0 – DB7	--	--	100	ns
T _H	Data Hold Time	Pins: DB0 – DB7	10	--	--	ns
Interface Mode with LCD Driver (ST7065)						
T _{CWH}	Clock Pulse with High	Pins: CL1, CL2	800	--	--	ns
T _{CWL}	Clock Pulse with Low	Pins: CL1, CL2	800	--	--	ns
T _{CST}	Clock Setup Time	Pins: CL1, CL2	500	--	--	ns
T _{SU}	Data Setup Time	Pin: D	300	--	--	ns
T _{DH}	Data Hold Time	Pin: D	300	--	--	ns
T _{DM}	M Delay Time	Pin: M	0	--	2000	ns

● Writing data from MPU to ST7066U

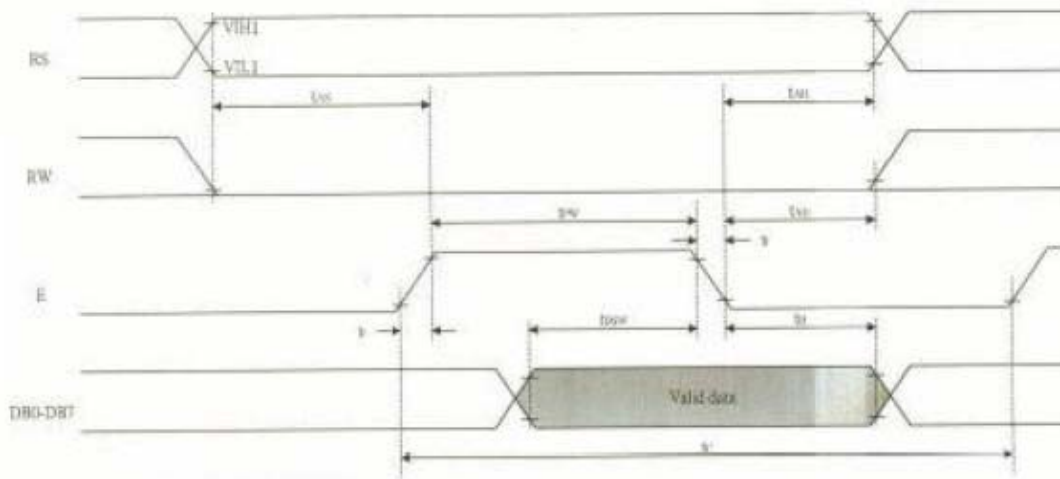

● Reading data from ST7066U to MPU

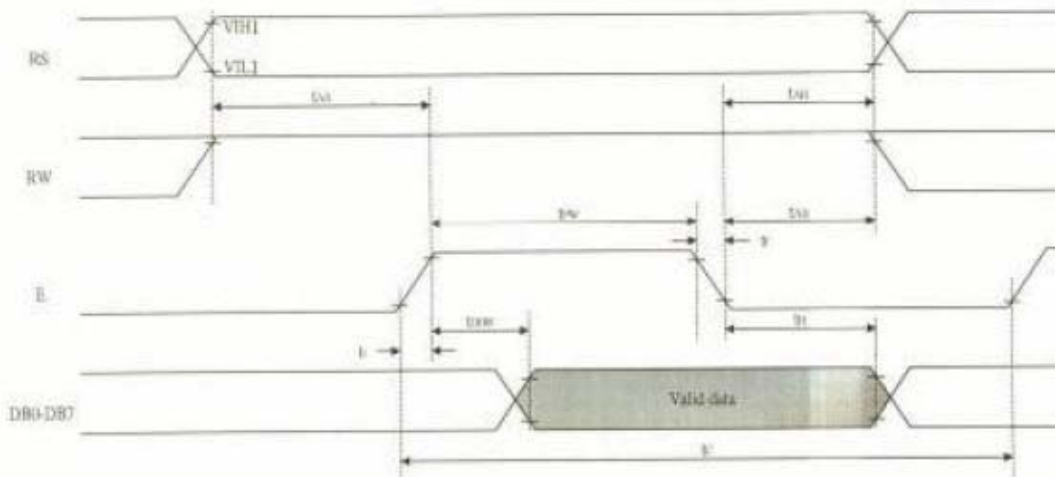

8.3 CHARACTER FONT

b7-b4 b3-b0	0000	0001	0010	0011	0100	0101	0110	0111	1000	1001	1010	1011	1100	1101	1110	1111
0000	CG RAM (1)			0	a	P	\	P				-	9	E	&	P
0001	(2)		.	1	A	D	a	A			.	A	*	4	a	9
0010	(3)		"	2	B	R	b	r			"	4	9	*	P	9
0011	(4)		#	3	C	S	c	s			#	9	T	E	E	*
0100	(5)		\$	4	D	T	d	t			\$	E	T	P	P	9
0101	(6)		%	5	E	U	e	u			%	T	*	1	E	9
0110	(7)		&	6	F	V	f	v			&	9	2	9	P	Σ
0111	(8)		'	7	G	W	g	w			'	*	9	9	g	π
1000	(1)		<	8	H	X	h	x			<	9	*	9	9	Σ
1001	(2)		>	9	I	Y	i	y			>	9	9	9	9	9
1010	(3)		*	:	J	Z	j	z			*	9	9	9	9	π
1011	(4)		+	:	K	E	k	e			+	9	9	9	9	π
1100	(5)		.	<	L	#	l	l			.	9	9	9	9	π
1101	(6)		-	=	M	J	m	j			-	9	9	9	9	÷
1110	(7)		.	>	N	^	n	+			.	9	9	9	9	π
1111	(8)		/	?	O	_	o	←			/	9	9	9	9	▣

9 BLOCK DIAGRAM

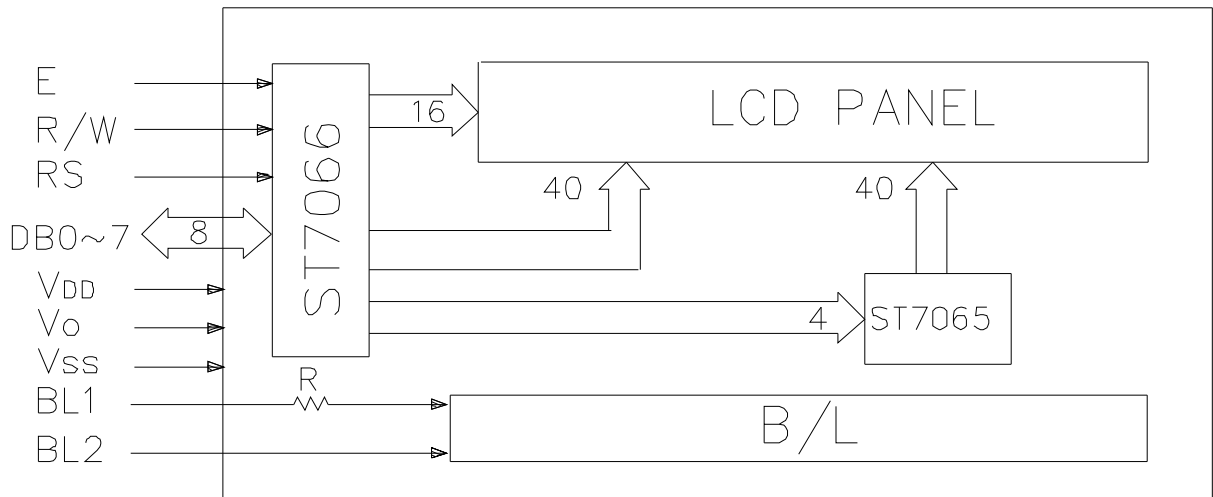

10 POWER SUPPLY

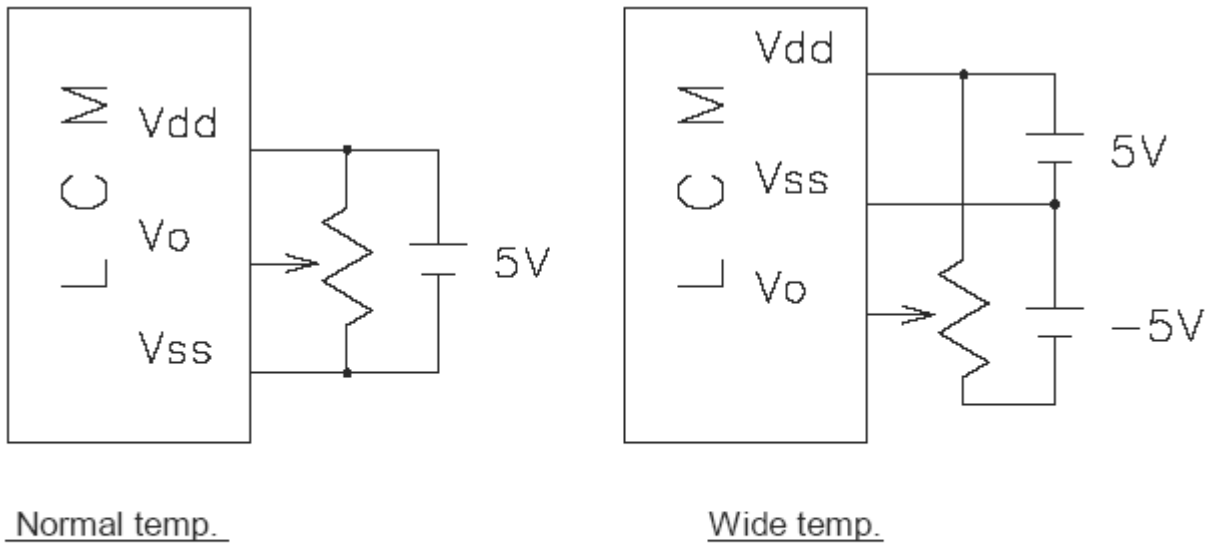

RECOMMENDED V_R : 10K ohm ~ 20K ohm

11 RELIABILITY TEST

11.1 RELIABILITY NORMAL TEMPERATURE

Test Item	Test Condition	Note
High Temperature Operation	240 HR , 50 °C +/- 2 °C	No abnormalities in function* and appearance**
Low Temperature Operation	240 HR , 0 °C +/- 2 °C	
Thermal Shock Storage (non operational)	-20°C (30 min.) -> 25°C (5 min.) -> 70°C (30 min.) ->25 °C (5 min.) 5 cycle	
Vibration (non operational)	10 Hz ~ 55 Hz 0.3 mm / 1 Octave 55 Hz ~ 500 Hz 3g / 1 Octave 20 cycle / per axis	

11.2 RELIABILITY WIDE TEMPERATURE

Test Item	Test Condition	Note
High Temperature Operation	240 HR , 70 °C +/- 2 °C	No abnormalities in function* and appearance**
Low Temperature Operation	240 HR , -20 °C +/- 2 °C	
Thermal Shock Storage (non operational)	-30°C (30 min.) -> 25°C (5 min.) -> 80°C (30 min.) ->25 °C (5 min.) 5 cycle	
Vibration (non operational)	10 Hz ~ 55 Hz 0.3 mm / 1 Octave 55 Hz ~ 500 Hz 3g / 1 Octave 20 cycle / per axis	

MTBF of liquid crystal panel

50,000 hours, 90% Confidence Level at 25 °C , 65% RH Max.

If any of the following occurs after the MTBF test, the LCD is deemed to be failed:

- Current consumption increase three times than initial value
- Damaged glass plug and/or polarizer on the LCD glass
- Non-operational display

12 STANDARD OF APPEARANCE INSPECTION

units: mm

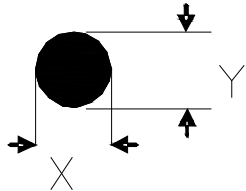
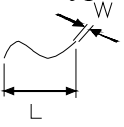
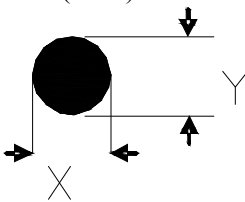
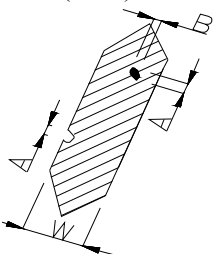
No.	Item	Criteria																																			
1	Black spot, White spot, dust	<p>Round type: as per following drawing $\Phi = (X+Y)/2$</p>  <table border="1" style="margin-left: 20px;"> <thead> <tr> <th colspan="3">Acceptable quantity</th> </tr> <tr> <th>size</th> <th>Zone A</th> <th>Zone B</th> </tr> </thead> <tbody> <tr> <td>$\Phi < 0.1$</td> <td>Any number</td> <td rowspan="4">Any number</td> </tr> <tr> <td>$0.1 < \Phi < 0.2$</td> <td>2</td> </tr> <tr> <td>$0.2 < \Phi < 0.25$</td> <td>1</td> </tr> <tr> <td>$0.25 < \Phi$</td> <td>0</td> </tr> </tbody> </table> <p>Line type: as per following drawing</p>  <table border="1" style="margin-left: 20px;"> <thead> <tr> <th colspan="4">Acceptable quantity</th> </tr> <tr> <th>Length</th> <th>Width</th> <th>Zone A</th> <th>Zone B</th> </tr> </thead> <tbody> <tr> <td>-</td> <td>$W \leq 0.02$</td> <td rowspan="2">Any number</td> <td rowspan="4">Any number</td> </tr> <tr> <td>$L \leq 3.0$</td> <td>$0.02 < W \leq 0.03$</td> </tr> <tr> <td>$L \leq 2.5$</td> <td>$0.03 < W \leq 0.05$</td> <td>2</td> </tr> <tr> <td>-</td> <td>$0.05 < W$</td> <td>as round type</td> </tr> </tbody> </table> <p style="text-align: center;">Total acceptable quantity: 3</p>	Acceptable quantity			size	Zone A	Zone B	$\Phi < 0.1$	Any number	Any number	$0.1 < \Phi < 0.2$	2	$0.2 < \Phi < 0.25$	1	$0.25 < \Phi$	0	Acceptable quantity				Length	Width	Zone A	Zone B	-	$W \leq 0.02$	Any number	Any number	$L \leq 3.0$	$0.02 < W \leq 0.03$	$L \leq 2.5$	$0.03 < W \leq 0.05$	2	-	$0.05 < W$	as round type
Acceptable quantity																																					
size	Zone A	Zone B																																			
$\Phi < 0.1$	Any number	Any number																																			
$0.1 < \Phi < 0.2$	2																																				
$0.2 < \Phi < 0.25$	1																																				
$0.25 < \Phi$	0																																				
Acceptable quantity																																					
Length	Width	Zone A	Zone B																																		
-	$W \leq 0.02$	Any number	Any number																																		
$L \leq 3.0$	$0.02 < W \leq 0.03$																																				
$L \leq 2.5$	$0.03 < W \leq 0.05$	2																																			
-	$0.05 < W$	as round type																																			
2	Polariser scratch	<p>Scratch on protective film is permitted Scratch on polariser: same as No. 1</p>																																			
3	Polariser bubble	<p>$\Phi = (X+Y)/2$</p>  <table border="1" style="margin-left: 20px;"> <thead> <tr> <th colspan="3">Acceptable quantity</th> </tr> <tr> <th>Size</th> <th>Zone A</th> <th>Zone B</th> </tr> </thead> <tbody> <tr> <td>$\Phi < 0.2$</td> <td>Any number</td> <td rowspan="4">Any number</td> </tr> <tr> <td>$0.2 < \Phi < 0.5$</td> <td>2</td> </tr> <tr> <td>$0.5 < \Phi < 1.0$</td> <td>1</td> </tr> <tr> <td>$1.0 < \Phi$</td> <td>0</td> </tr> </tbody> </table> <p style="text-align: center;">Total acceptable quantity: 3</p>	Acceptable quantity			Size	Zone A	Zone B	$\Phi < 0.2$	Any number	Any number	$0.2 < \Phi < 0.5$	2	$0.5 < \Phi < 1.0$	1	$1.0 < \Phi$	0																				
Acceptable quantity																																					
Size	Zone A	Zone B																																			
$\Phi < 0.2$	Any number	Any number																																			
$0.2 < \Phi < 0.5$	2																																				
$0.5 < \Phi < 1.0$	1																																				
$1.0 < \Phi$	0																																				
4	Segment deformation	<p>1.a. Pin hole on segmented display</p> <p>W: segment width $\Phi = (A+B)/2$</p>  <table border="1" style="margin-left: 20px;"> <thead> <tr> <th colspan="2">Acceptable quantity</th> </tr> <tr> <th>Width</th> <th>Φ</th> </tr> </thead> <tbody> <tr> <td>$W \leq 0.4$</td> <td>$\Phi \leq 0.2$ and $\Phi \leq 1/2W$</td> </tr> <tr> <td>$W > 0.4$</td> <td>$\Phi \leq 0.25$ and $\Phi \leq 1/3W$</td> </tr> </tbody> </table> <p style="text-align: center;">Total acceptable quantity: 1 defect per segment Pin holes with Φ under 0.10 mm are acceptable.</p>	Acceptable quantity		Width	Φ	$W \leq 0.4$	$\Phi \leq 0.2$ and $\Phi \leq 1/2W$	$W > 0.4$	$\Phi \leq 0.25$ and $\Phi \leq 1/3W$																											
Acceptable quantity																																					
Width	Φ																																				
$W \leq 0.4$	$\Phi \leq 0.2$ and $\Phi \leq 1/2W$																																				
$W > 0.4$	$\Phi \leq 0.25$ and $\Phi \leq 1/3W$																																				

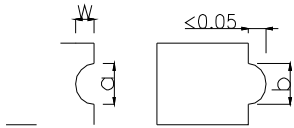
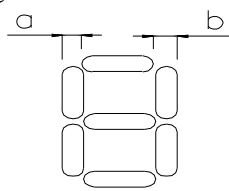
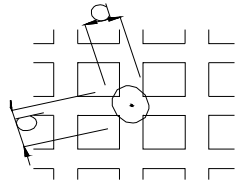
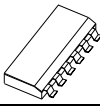
No.	Item	Criteria																												
5	Black spot, White spot, dust	<p>1b. Pin hole on dot matrix display</p>  <table border="1" style="margin-left: auto; margin-right: auto;"> <thead> <tr> <th colspan="2">Acceptable quantity</th> </tr> <tr> <th>Size</th> <th></th> </tr> </thead> <tbody> <tr> <td>$a, b < 0.1$</td> <td>Any number</td> </tr> <tr> <td>$(a+b)/2 \le 0.1$</td> <td>Any number</td> </tr> <tr> <td>$0.5 < \Phi < 1.0$</td> <td>3</td> </tr> </tbody> </table> <p>2. Segments / dots with different width</p>  <table border="1" style="margin-left: auto; margin-right: auto;"> <thead> <tr> <th colspan="2">Acceptable</th> </tr> </thead> <tbody> <tr> <td>$a > b$</td> <td>$a/b \le 4/3$</td> </tr> <tr> <td>$a < b$</td> <td>$a/b > 4/3$</td> </tr> </tbody> </table> <p>3. Alignment layer defect $\Phi = (a+b)/2$</p>  <table border="1" style="margin-left: auto; margin-right: auto;"> <thead> <tr> <th colspan="2">Acceptable quantity</th> </tr> <tr> <th>Size</th> <th></th> </tr> </thead> <tbody> <tr> <td>$\Phi \le 0.4$</td> <td>Any number</td> </tr> <tr> <td>$0.4 < \Phi \le 1.0$</td> <td>5</td> </tr> <tr> <td>$1.0 < \Phi \le 1.5$</td> <td>3</td> </tr> <tr> <td>$1.5 < \Phi \le 2.0$</td> <td>2</td> </tr> </tbody> </table>	Acceptable quantity		Size		$a, b < 0.1$	Any number	$(a+b)/2 \le 0.1$	Any number	$0.5 < \Phi < 1.0$	3	Acceptable		$a > b$	$a/b \le 4/3$	$a < b$	$a/b > 4/3$	Acceptable quantity		Size		$\Phi \le 0.4$	Any number	$0.4 < \Phi \le 1.0$	5	$1.0 < \Phi \le 1.5$	3	$1.5 < \Phi \le 2.0$	2
Acceptable quantity																														
Size																														
$a, b < 0.1$	Any number																													
$(a+b)/2 \le 0.1$	Any number																													
$0.5 < \Phi < 1.0$	3																													
Acceptable																														
$a > b$	$a/b \le 4/3$																													
$a < b$	$a/b > 4/3$																													
Acceptable quantity																														
Size																														
$\Phi \le 0.4$	Any number																													
$0.4 < \Phi \le 1.0$	5																													
$1.0 < \Phi \le 1.5$	3																													
$1.5 < \Phi \le 2.0$	2																													
6	Colour uniformity	Level of sample for approval set as limit sample																												
7	Backlight	The backlight colour should correspond to the product specification Flashing and or unlit backlight is not allowed Dust larger than 0.25 mm is not allowed																												
8	COB	Exposed wire bond pad is not allowed Insufficient covering with resin is not allowed (wire bond line exposed) Dust or bubble on the resin are not allowed																												
9	PCB 	No unmelted solder paste should be present on PCB Cold solder joints, missing solder connections, or oxidation are not allowed No residue or solder balls on PCB are allowed Short circuits on components are not allowed																												
10	Tray particles	<table border="1" style="width: 100%; border-collapse: collapse;"> <thead> <tr> <th></th> <th>Size</th> <th>Quantity</th> </tr> </thead> <tbody> <tr> <td rowspan="2" style="text-align: center;">On tray</td> <td style="text-align: center;">$\Phi < 0.2$</td> <td style="text-align: center;">Any number</td> </tr> <tr> <td style="text-align: center;">$\Phi > 0.25$</td> <td style="text-align: center;">4</td> </tr> <tr> <td rowspan="2" style="text-align: center;">On display</td> <td style="text-align: center;">$\Phi \ge 0.25$</td> <td style="text-align: center;">2</td> </tr> <tr> <td style="text-align: center;">$L = 3$</td> <td style="text-align: center;">1</td> </tr> </tbody> </table>		Size	Quantity	On tray	$\Phi < 0.2$	Any number	$\Phi > 0.25$	4	On display	$\Phi \ge 0.25$	2	$L = 3$	1															
	Size	Quantity																												
On tray	$\Phi < 0.2$	Any number																												
	$\Phi > 0.25$	4																												
On display	$\Phi \ge 0.25$	2																												
	$L = 3$	1																												

13 PART NUMBER DESCRIPTION

LR4422①②2C16③④⑤

①

Polarizer Type

B = Transflective: light background with LED backlight
E = Transmissive: dark background with LED backlight
F = Transmissive: light background with LED backlight
A = Reflective: No backlight

②

Backlight Color

G = Yellow-green (standard)

③

Fluid Type and Power Supply

S = NTN with +5VDC operation
H = NTN-H with ±5VDC operation

④

Fluid Type/TN Viewing Direction

N = NTN, NTN-H

⑤

Background Color for NTN or TN Temperature Range

B = Blue background
G = Gray background
Y = Yellow background

14 HANDLING PRECAUTIONS

Safety

If the LCD panel breaks, be careful not to get the liquid crystal fluid in your mouth or in your eyes.
If the liquid crystal touches your skin or clothes, wash it off immediately using soap and plenty of water.

Mounting and Design

Place a transparent plate (e.g. acrylic, polycarbonate or glass) on the display surface to protect the display from external pressure. Leave a small gap between the transparent plate and the display surface.
When assembling with a zebra connector, clean the surface of the pads with alcohol and keep the surrounding air very clean. Design the system so that no input signal is given unless the power supply voltage is applied.

Caution during LCD cleaning

Lightly wipe the display surface with a soft cloth soaked with Isopropyl alcohol, Ethyl alcohol or Trichlorotrifluoroethane. Do not wipe the display surface with dry or hard materials that will damage the polariser surface. Do not use aromatic solvents (toluene and xylene), or ketonic solvents (ketone and acetone).

Caution against static charge

As the display uses C-MOS LSI drivers, connect any unused input terminal to VDD or VSS. Do not input any signals before power is turned on. Also, ground your body, work/assembly table and assembly equipment to protect against static electricity.

Packaging

Displays use LCD elements, and must be treated as such. Avoid strong shock and drop from a height.
To prevent displays from degradation, do not operate or store them exposed directly to sunshine or high temperature/humidity.

Caution during operation

It is indispensable to drive the display within the specified voltage limit since excessive voltage shortens its life. Direct current causes an electrochemical reaction with remarkable deterioration of the display quality. Give careful consideration to prevent direct current during ON/OFF timing and during operation.
Response time is extremely delayed at temperatures lower than the operating temperature range while, at high temperatures, displays become dark. However, this phenomenon is reversible and does not mean a malfunction or a display that has been permanently damaged. If the display area is pushed on hard during operation, some graphics will be abnormally displayed but returns to a normal condition after turning off the display once. Even a small amount of condensation on the contact pads (terminals) can cause an electrochemical reaction which causes missing rows and columns. Give careful attention to avoid condensation.

Storage

Store the display in a dark place where the temperature is $25^{\circ}\text{C} \pm 10^{\circ}\text{C}$ and the humidity below 50%RH.
Store the display in a clean environment, free from dust, organic solvents and corrosive gases.
Do not crash, shake or jolt the display (including accessories).

Product No.	LR4422	REV. B
-------------	--------	--------

Page	19 / 19
------	---------