

Features

- Colorless transparency lens type
- $\phi 3\text{mm}$ (T-1) all plastic mold type
- High luminosity

Outline dimensions

(unit : mm)

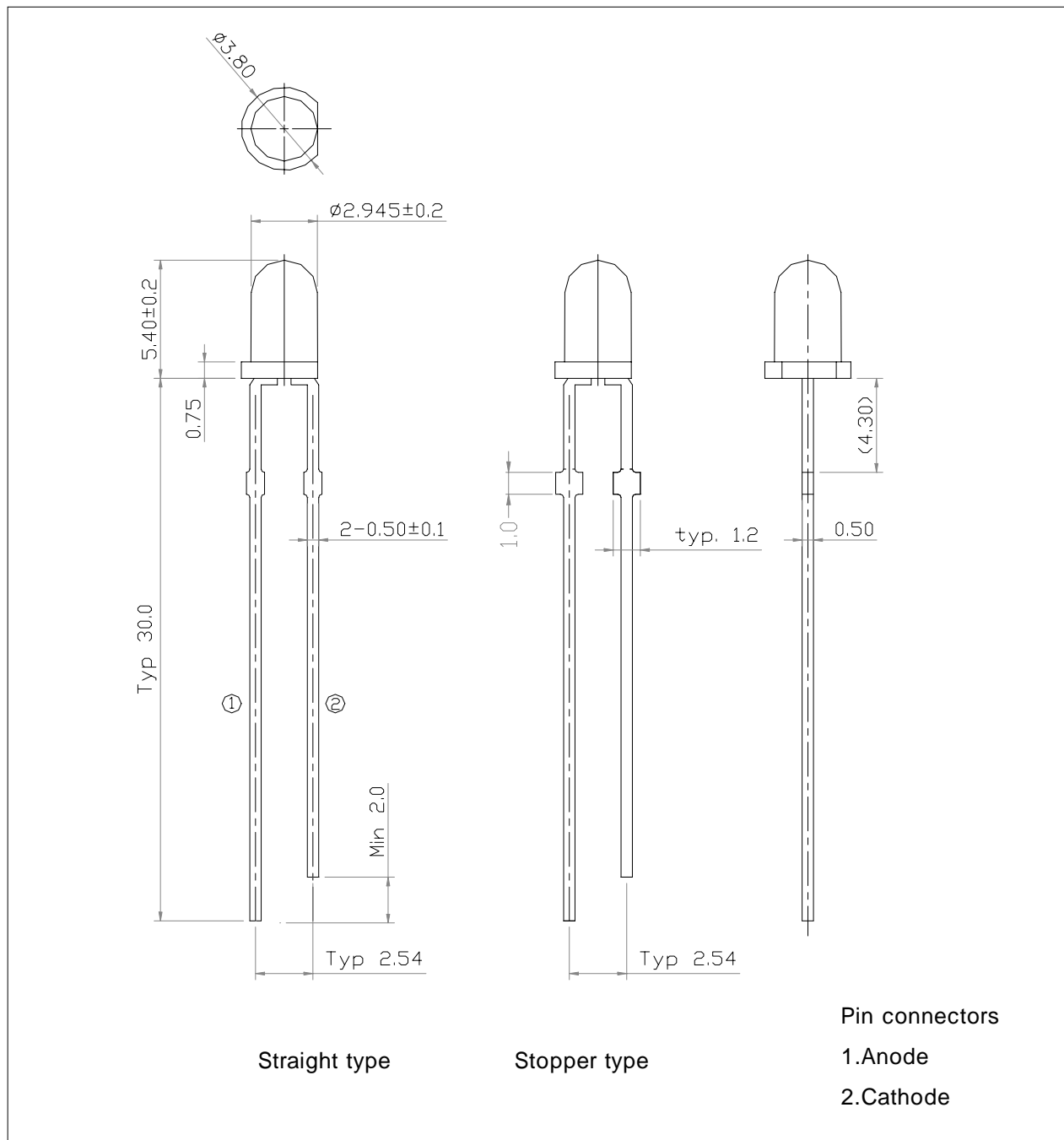

Absolute maximum ratings

Characteristic	Symbol	Ratings	Unit
Power dissipation	P_D	100	mW
Forward Current	I_F	30	mA
*1Peak Forward Current	I_{FP}	50	mA
Reverse Voltage	V_R	5	V
Operating Temperature	T_{opr}	-25 85	
Storage Temperature	T_{stg}	-30 100	
*2Soldering Temperature	T_{sol}	260 for 3 seconds	

*1.Duty ratio = 1/16, Pulse width = 0.1ms

*2.Keep the distance more than 2.0mm from PCB to the bottom of LED package

Electrical – Optical Characteristics

(Ta=25)

Characteristic	Symbol	Test Condition	Min.	Typ.	Max.	Unit
Forward Voltage	V_F	$I_F= 20mA$	-	1.9	2.2	V
Dominant Wavelength	λ_D	$I_F= 20mA$	-	645	-	nm
Spectrum Bandwidth		$I_F= 20mA$	-	20	-	nm
Reverse Current	I_R	$V_R=5V$	-	-	10	Ua
*3Half Angle	$\theta_{1/2}$	$I_F= 20mA$	-	± 17	-	deg

*3. $\theta_{1/2}$ is the off - axis angle where the luminous intensity is 1/2 the peak intensity

Luminous intensity ranks

(Ta=25)

Iv RANK	Test Condition	Min.	Typ.	Max.	Unit
O	I _F = 20mA	850	-	1200	mcd
P		1200	-	1700	
Q		1700	-	2400	
R		1700	-	2400	

* Luminous intensity is tested at a current pulse duration of 25 ms and an accuracy of $\pm 11\%$.

Intensity Measured : 0.01sr(CIE. LED_B)

Precautions On LED using

* To avoid optical difference, Please do not mix differently-ranked product.

Characteristic Diagrams

Fig. 1 I_F - V_F

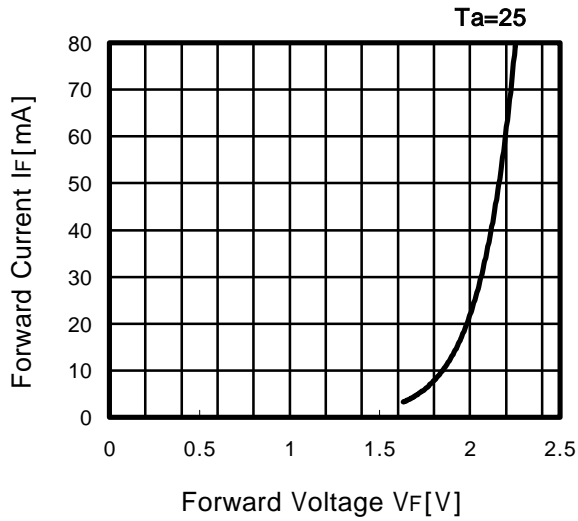

Fig. 2 I_v - I_F

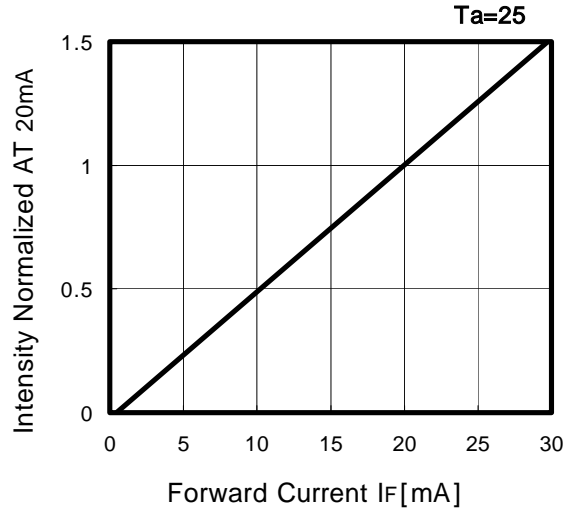

Fig. 3 Spectrum Distribution

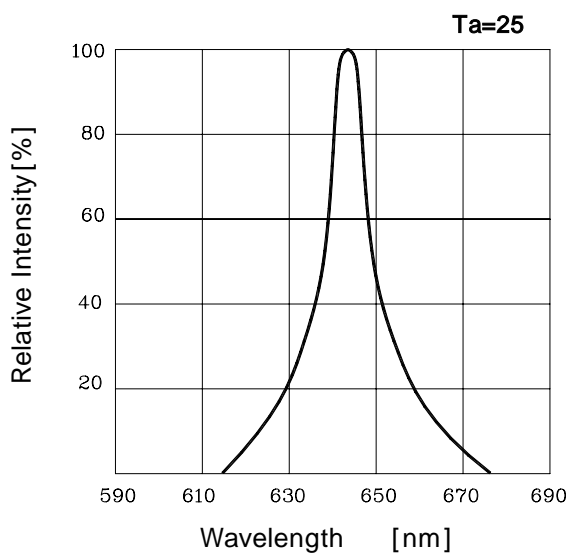

Fig. 4 Relative Intensity- T_a

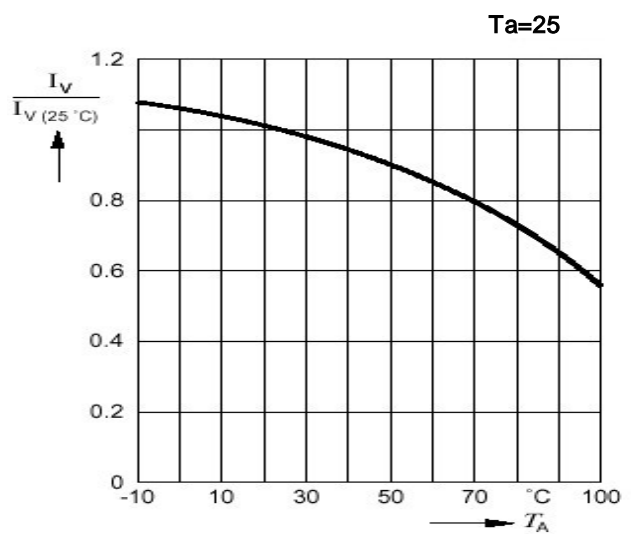
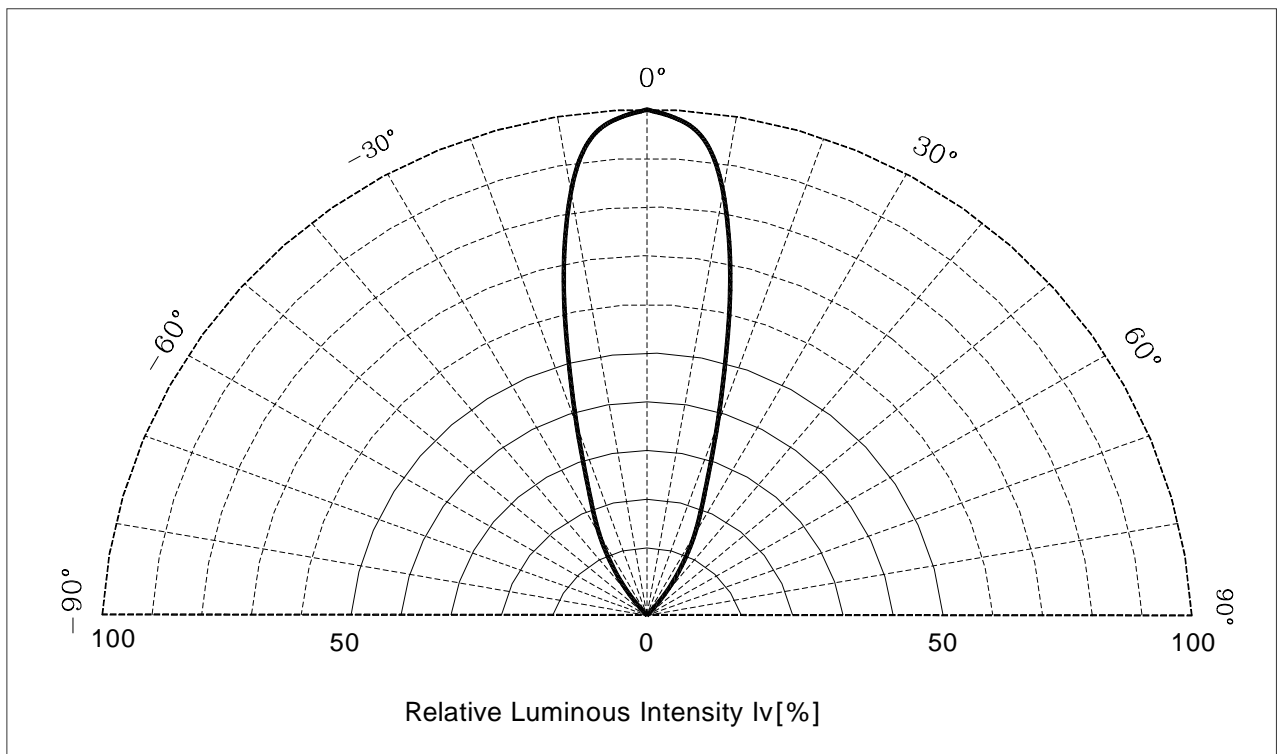

Fig. 5 Radiation Diagram



Revision history sheet

Spec NO.			
Title	Specification for Approval		
Times	Date	Summary of revision	Remarks
1	2001. 07. 15		
2	2003. 02. 26	Format	