

**TENTATIVE/CONFIDENTIAL**

# **TECHNICAL LITERATURE**

MODEL NO. **LS022Q8UX05**

DOC. NO. **LCY-2506804**

DATE **AUG.31.2006**

\*\* The technical literature is subject to be changed without notice

## **SHARP CORPORATION**

PRESENTED  
BY

---

Akira Imai  
General Manager  
Engineering Department V  
Mobile LCD Design Center  
Mobile LCD Group II  
SHARP CORPORATION



**NOTICE**

- These specification sheets are the proprietary product of SHARP CORPORATION ("SHARP") and include materials protected under copyright of SHARP. Do not reproduce or cause any third party to reproduce them in any form or by any means, electronic or mechanical, for any purpose, in whole or in part, without the express written permission of SHARP.
- The application examples in these specification sheets are provided to explain the representative applications of the device and are not intended to guarantee any industrial property right or other rights or license you to use them. SHARP assumes no responsibility for any problems related to any industrial property right of a third party resulting from the use of the device.
- The device listed in these specification sheets was designed and manufactured for use in Telecommunication equipment (terminals)
- In case of using the device for applications such as control and safety equipment for transportation(aircraft,trains, automobiles, etc. ), rescue and security equipment and various safety related equipment which require higher reliability and safety, take into consideration that appropriate measures such as fail-safe functions and redundant system design should be taken.
- Do not use the device for equipment that requires an extreme level of reliability, such as aerospace applications, telecommunication equipment (trunk lines), nuclear power control equipment and medical or other equipment for life support.
- SHARP assumes no responsibility for any damage resulting from the use of the device which does not comply with the instructions and the precautions specified in these specification sheets.
- Contact and consult with a SHARP sales representative for any questions about this device.

**[For handling and system design]**

- (1) Do not scratch the surface of the polarizer film as it is easily damaged.
- (2) If the cleaning of the surface of the LCD panel is necessary, wipe it swiftly with cotton or other soft cloth. Do not use organic solvent as it damages polarizer.
- (3) Water droplets on polarizer must be wiped off immediately as they may cause color changes, or other defects if remained for a long time.
- (4) Since this LCD panel is made of glass, dropping the module or banging it against hard objects may cause cracks or fragmentation.
- (5) Certain materials such as epoxy resin (amine's hardener) or silicone adhesive agent (de-alcohol or de-oxym) emits gas to which polarizer reacts(color change). Check carefully that gas from materials used in system housing or packaging do not hart polarizer.
- (6) Liquid crystal material will freeze below specified storage temperature range and it will not get back to normal quality even after temperature comes back within specified temperature range. Liquid crystal material will become isotropic above specified temperature range and may not get back to normal quality. Keep the LCD module always within specified temperature range.
- (7) Do not expose LCD module to the direct sunlight, or to strong ultraviolet light for long time.
- (8) If the LCD driver IC (COG) is exposed to light, normal operation may be impeded. It is necessary to design so that the light is shut off when the LCD module is mounted.
- (9) Do not disassemble the LCD module as it may cause permanent damage.

(10) As this LCD module contains components sensitive to electrostatic discharge, be sure to follow the instructions in below.

Operators

Operators must wear anti-static wears to prevent electrostatic charge up to and discharge from human body.

Equipment and containers

Process equipment such as conveyer, soldering iron, working bench and containers may possibly generate electrostatic charge up and discharge. Equipment must be grounded through 100Mohms resistance. Use ion blower.

Floor

Floor is an important part to leak static electricity which is generated from human body or equipment.

There is a possibility that the static electricity is charged to them without leakage in case of insulating floor, so the countermeasure (electrostatic earth:  $1 \times 10^8$  ) should be made.

Humidity

Proper humidity of working room may reduce the risk of electrostatic charge up and discharge. Humidity should be kept over 50% all the time.

Transportation/storage

Storage materials must be anti-static to prevent causing electrostatic discharge.

Others

Protective film is attached on the surface of LCD panel to prevent scratches or other damages. When removing this protective film, remove it slowly under proper anti-ESD control such as ion blower.

(11) Hold LCD very carefully when placing LCD module into the system housing. Do not apply excessive stress or pressure to LCD module. Do not to use chloroprene rubber as it may affect on the reliability of the electrical interconnection.

(12) Do not hold or touch LCD panel to flex interconnection area as it may be damaged.

(13) As the binding material between LCD panel and flex connector mentioned in 12) contains an organic material, any type of organic solvents are not allowed to be used. Direct contact by fingers are also prohibited.

(14) When carrying the LCD module, place it on the tray to protect from mechanical damage. It is recommended to use the conductive trays to protect the CMOS components from electrostatic discharge. When holding the module, hold the Plastic Frame of LCD module so that the panel ,COG and other electric parts are not damaged.

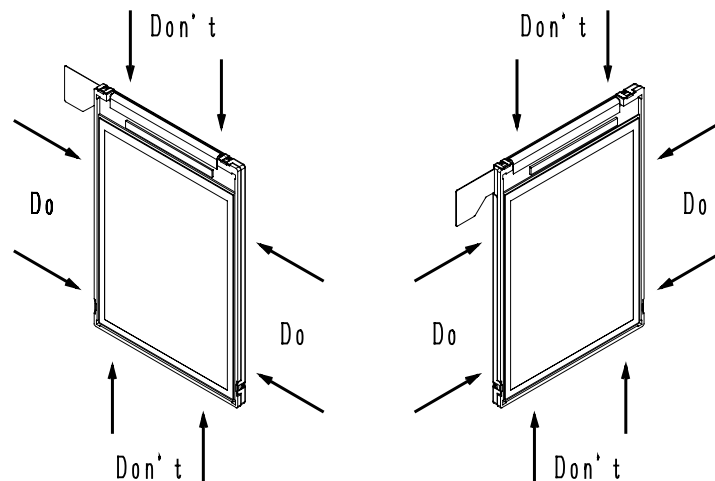

(15) Do not touch the COG 's patterning area. Otherwise the circuit may be damaged.

(16) Do not touch LSI chips as it may cause a trouble in the inner lead connection.

(17) Place a protective cover on the LCD module to protect the glass panel from mechanical damages.

(18) LCD panel is susceptible to mechanical stress and even the slightest stress will cause a color change in background. So make sure the LCD panel is placed on flat plane without any continuous twisting, bending or pushing stress.

(19) Protective film is placed onto the surface of LCD panel when it is shipped from factory. Make sure to peel it off before assembling the LCD module into the system. Be very careful not to damage LCD module by electrostatic discharge when peeling off this protective film. Ion blower and ground strap are recommended.

(20) Make sure the mechanical design of the system in which the LCD module will be assembled matches specified viewing angle of this LCD module.

(21) This LCD module does not contain nor use any ODS(1,1,1-Trichloroethane , CCL4) in all materials used, in all production processes.

### [For operating LCD module]

(1) Do not operate or store the LCD module under outside of specified environmental conditions.

(2) At the shipment, adjust the contrast of each LCD module with electric volume. LCD contrast may vary from panel to panel depending on variation of LCD power voltage from system.

(3) As opto-electrical characteristics of LCD will be changed, dependent on the temperature, the confirmation of display quality and characteristics has to be done after temperature is set at 25 °C and it becomes stable.

### [Precautions for Storage]

(1) Do not expose the LCD module to direct sunlight or strong ultraviolet light for long periods. Store in a dark place.

(2) The liquid crystal material will solidify if stored below the rated storage temperature and will become an isotropic liquid if stored above the rated storage temperature, and may not retain its original properties. Only store the module at normal temperature and humidity ( $25 \pm 5^{\circ}\text{C}$ ,  $60 \pm 10\%RH$ ) in order to avoid exposing the front polarizer to chronic humidity.

(3) Keeping Method

a. Don't keeping under the direct sunlight.

b. Keeping in the tray under the dark place.

## DON'T

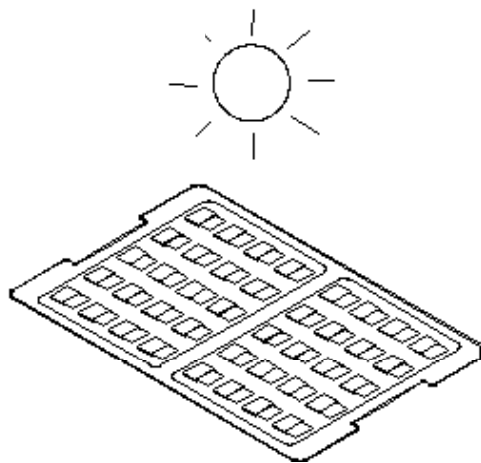

## DO

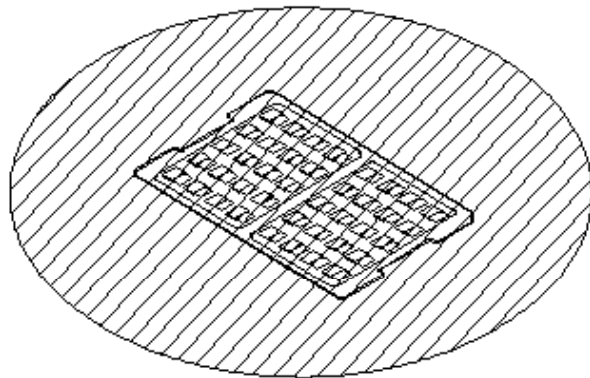

(1) Do not operate or store the LCD module under outside of specified environmental conditions.

(2) Be sure to prevent light striking the chip surface.

**[Other Notice]**

- (1) Do not operate or store the LCD module under outside of specified environmental conditions.
- (2) As electrical impedance of power supply lines (VDD-VSS) are low when LCD module is working, place the de-coupling capacitor near by LCD module as close as possible.
- (3) Reset signal must be sent after power on to initialize LSI. LSI does not function properly until initialize it by reset signal.
- (4) Generally, At power on, in order not to apply DC charge directly to LCD panel, supply logic voltage first and initialize LSI logic function including polarity alternation. Then supply voltage for LCD bias. At power off, in order not to apply DC charge directly to LCD panel, execute Power OFF sequence and Discharge command.
- (5) Don't touch to PWB surface, exposed IC chip, electric parts and other parts, to any electric, metallic materials.
- (6) No bromide specific fire-retardant material is used in this module.
- (7) Do not display still picture on the display over 2 hours as this will damage the liquid crystal.

**[Precautions for Discarding Liquid Crystal Modules]**

COG : After removing the LSI from the liquid crystal panel, dispose of it in a similar way to circuit boards from electronic devices.

LCD panel : Dispose of as glass waste. This LCD module contains no harmful substances. The liquid crystal panel contains no dangerous or harmful substances. The liquid crystal panel only contains an extremely small amount of liquid crystal (approx.100mg) and therefore it will not leak even if the panel should break.  
-Its median lethal dose (LD50) is greater than 2,000 mg/kg and a mutagenetic (Aims test: negative) material material is employed.

FPC : Dispose of as similar way to circuit board from electric device.

## 1. Application

This data sheet is to introduce the specification of LS022Q8UX05 active matrix 16,777,216 color LCD module. Color LCD module is controlled by Driver IC (R69406).

If any problem occurs concerning the items not stated in this specification, it must be solved sincerely by both parties after deliberation.

As to basic specification of driver IC refer to the IC specification and handbook.

## 2. Construction and Outline

Construction: LCD panel, Driver(COG), FPC with electric components,  
(4)White LED lump, prism sheet, diffuser, light guide and reflector, plastic frame to fix them mechanically.

Outline: See page 19.

Connection: 27 pins; 0.3mm pitch

There shall be no scratches, stains, chips, distortions and other external drawbacks that may affect the display function.

Rejection criteria shall be noted in Inspection Standard (S-U-056-xx)

In order to realize thin module structure, double-sided adhesive tapes are used to fix LCD panels. As these tapes do not guarantee to permanently fix the panels, LCD panel may rise from the module when shipped from factory. So please make sure to design the system to hold the edges of LCD panel by the soft material such as sponge when LCD module is assembled into the cabinet.

## 3. Mechanical Specification

Table 1

Parameter		Specifications	Unit
Outline dimensions (typ)		(39.20) (W) × (56.35) (H) × (2.3) (D)	mm
Main LCD Panel	Active area	33.48 (W) × 44.64 (H)	mm
	Display format	240 × RGB(W) × 320(H)	-
	Dot pitch	0.0465 (W) × 0.1395 (H)	mm
	Base color *1	Normally black	-
Mass		Approx (T.B.D)	g

\*1 Due to the characteristics of the LC material, the colors vary with environmental temperature.

## 4. Absolute Maximum Ratings

### (4-1) Electrical absolute maximum ratings

Table 2

Ta=25

Parameter	Symbol	Min	Max	Unit	Remark
Supply voltage	VDD-GND	-0.3	4.2	V	
	VDDI-GND	-0.3	4.2	V	
Input Voltage	V <sub>IN</sub>	-0.3	V <sub>DDI</sub> +0.5	V	*1

\*1 Input terminal of logic system. : Voltage value is based on GND = 0V.

### Environment Conditions

Table 3

Item	Top		Tstg		Remark
	MIN.	MAX.	MIN.	MAX.	
Ambient temperature	-10 °C	+60°C	-20 °C	+70°C	Note 2)
Humidity	Note 1)		Note 1)		No condensation

Note1) Ta ≤ 40 °C.....95 % RH Max

Note2) Ta > 40 °C.....Absolute humidity shall be less than Ta=40 °C /95 % RH.

As opt-electrical characteristics of LCD will be changed, dependent on the temperature, the confirmation of display quality and characteristics has to be done after temperature is set at 25 °C and it becomes stable. Be sure not to exceed the rated voltage, otherwise a malfunction may occur.



## 5. Electrical Specifications

### (5-1) Electrical characteristics for main LCD

Table 4

Ta=25 , VDD=2.8V, VDDI=1.8V, GND=0V

Parameter	Symbol	Conditions	Min.	Typ.	Max.	Unit	Applicable Pin
Supply voltage	VDD-VSS	Ta=-10 ~ 60 °C	(2.7)	(2.8)	(2.9)	V	
Supply voltage	VDDI-VSS	Ta=-10 ~ 60 °C	(1.7)	(1.8)	(1.9)	V	
"H" level input voltage	V <sub>IHI</sub>	Ta=-10 ~ 60 °C	0.7 V <sub>DDI</sub>	-	-	V	(note1)
"L" level input voltage	V <sub>ILI</sub>		-	-	0.3 V <sub>DDI</sub>	V	(note1)
Input leakage current	I <sub>LI</sub>	Ta=-10 ~ 60 °C	-10	-	10	μA	(note1)
Output leakage current	I <sub>LO</sub>	V <sub>IN</sub> = GND or VDDI	-10	-	10	μA	(note2)
"H" level output voltage	V <sub>OHI</sub>	Ta=-10 ~ 60 °C	0.8 V <sub>DDI</sub>	-	-	V	(note3)
"L" level output voltage	V <sub>OLI</sub>	I <sub>OHI</sub> =TBD mA , I <sub>OLI</sub> = TBD mA	-	-	0.2 V <sub>DDI</sub>	V	
Current consumption	I <sub>DD</sub>	Ta=25 °C	-	(5.0)	(T.B.D.)	mA	(note4)
	I <sub>DDI</sub>		-	(0.2)	(T.B.D.)	mA	(note4)

(note 1) Input mode of D0 ~ D7pins, CSX,WRX,RDX,D/CX,RESX

(note 2) Output mode of D0 ~ D7pins, TE.

(note 3) Output mode of D0 ~ D7 pins, TE.

(note4) Following Conditions

Ta=25 , frame frequency=60Hz

Display Pattern : All white. No Host CPU access.

## (5-2) LED back light

(1) At main panel the back light use 4pcs edge light type white LED.

Table 6

Parameter	Conditions	Symbol	Min.	Typ.	Max.	Unit	Remark
Forward current	Ta=25 °C	I <sub>LED1</sub>	-	(20) *1	-	mA	VLED+~VLED-
		I <sub>LED2</sub>	-	(20) *1	-	mA	VLED2+~VLED2-

LED lamp : NICHIA Corporation NSSW020BT

Luminous Intensity rank : V1 or V2

Color rank : b5(be1,be2,bf1,bf2)

\*1 per one piece of LED

\*Please consider Allowable Forward Current on used temperature  
(refer to Ambient Temperature vs. Allowable Forward Current curve)

■ Ambient Temperature vs. Allowable Forward Current

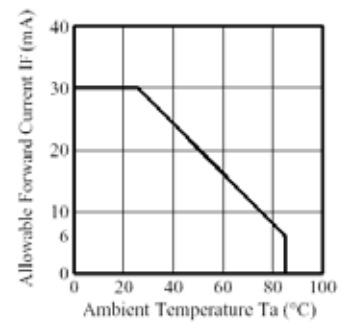

### LED circuit

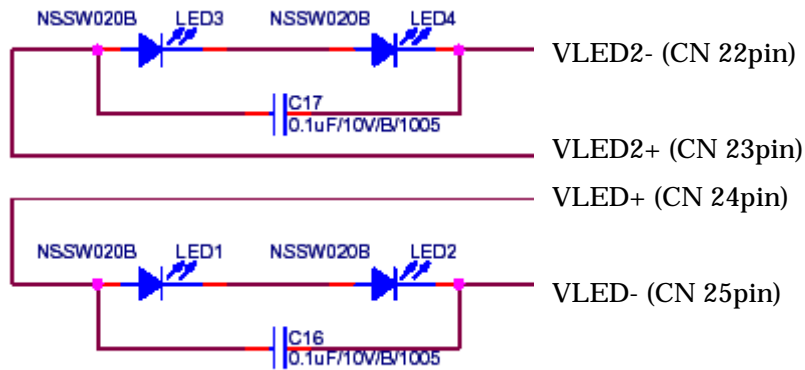

(5-3) Interface signals

Table 7

Pin No	Symbol	Description	I/O	Remarks
1	GND	Ground Level Pin		
2	VDDI	Power Supply (LCD Driver) for I/O		
3	VDD	Power Supply (LCD Driver) for Analog		
4	GND	Ground Level Pin		
5	TE	Tearing Effect Output	O	
6	RDX	Read enable	I	Low enable
7	WRX	Write enable	I	Low enable
8	D/CX	Data / Command selectable	I	Low :command High:display data / parameter
9	CSX	Chip Select	I	Low enable
10	GND	Ground Level Pin		
11	D0	Data Bus	I/O	
12	D1	Data Bus	I/O	
13	D2	Data Bus	I/O	
14	D3	Data Bus	I/O	
15	D4	Data Bus	I/O	
16	D5	Data Bus	I/O	
17	D6	Data Bus	I/O	
18	D7	Data Bus	I/O	
19	GND	Ground Level Pin		
20	RESX	Reset rnable	I	Low enable
21	GND	Ground Level Pin		
22	VLED2-	LED1~2 Cathode		
23	VLED2+	LED1~2 Anode		
24	VLED+	LED3~4 Anode		
25	LED-	LED3~4 Cathode	-	
26	GND	Ground Level Pin		
27	GND	Ground Level Pin		

Corresponded connector : 0.3mm pitch , ZIF Connector (HRS FH23-27S-0.3SHW)

Signals connecting to LCD module. Symbol correspondable to Circuit diagram

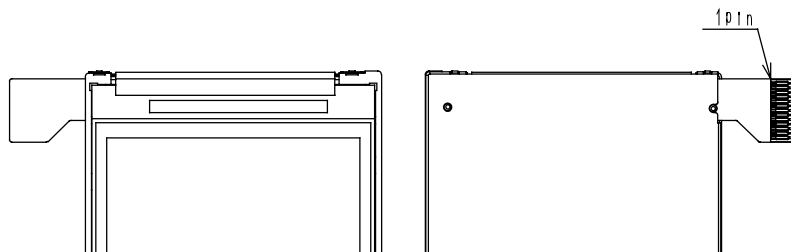

(5-4) Host Interface Timing Diagrams (80-family MPU access) for R69406

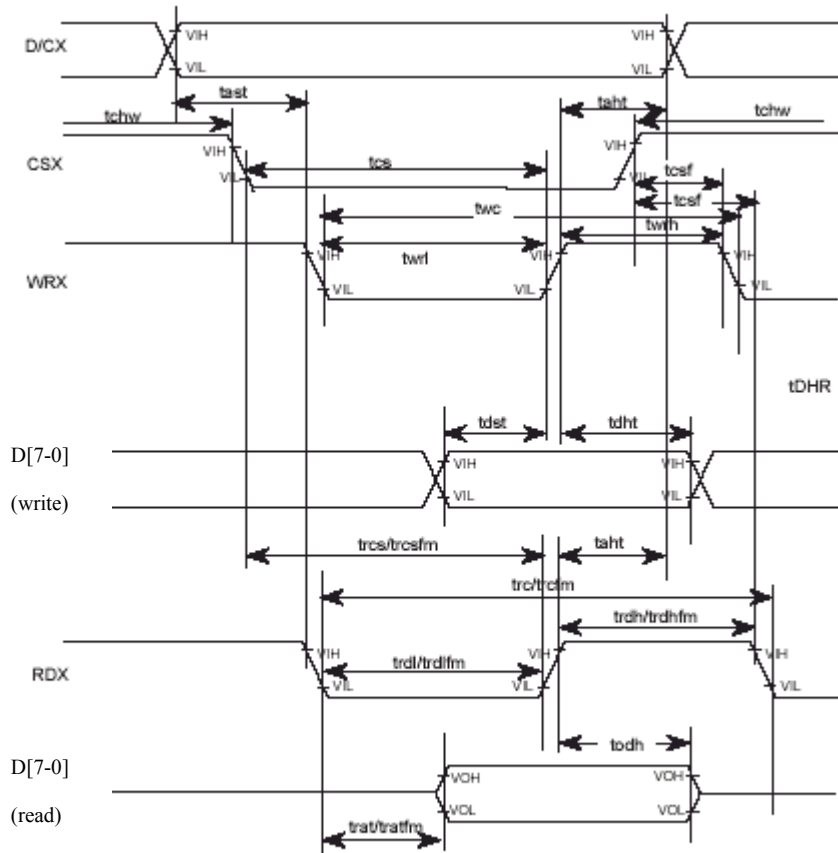

Notes: 1. The logic High and Low levels are defined by 70 and 30 percent of the IOVcc level, respectively.  
2. Fix unused pins of D[15:0] to either IOVcc or IOGND.

( $V_{CC} = 2.600V \sim 2.950V$ ,  $IOV_{CC} = 1.650V \sim 1.950V$ ,  $T_a = -30^{\circ}C \sim +75^{\circ}C$ )

Item	Symbol	unit	Timing diagram	Min.	Max.
Address setup time	D/CX	$t_{ast}$		10	-
Address hold time (Write/Read)		$t_{aht}$		10	-
CSX "H" pulse width	CSX	$t_{ch}$		0	-
Chip select setup time (Write)		$t_{cs}$		35	-
Chip select setup time (Read ID)		$t_{rcs}$		45	-
Chip select setup time (Read FM)		$t_{rcsfm}$		355	-
Chip select setup time (Write/Read)		$t_{csf}$		10	-
Write cycle time	WRX	$t_{wc}$		100	-
Control pulse "High" period		$t_{wrh}$		35	-
Control pulse "Low" period		$t_{wrl}$		35	-
Read cycle time (ID)	RDX(ID)	$t_{rc}$	ID data read	160	-
Control pulse "High" period (ID)		$t_{rdh}$		90	-
Control pulse "Low" period (ID)		$t_{rdl}$		45	-
Read cycle time (FM)	RDX(FM)	$t_{rcfm}$	Read from frame memory	450	-
Control pulse "High" period (FM)		$t_{rdhfm}$		90	-
Control pulse "Low" period (FM)		$t_{rdlfm}$		355	-
Data setup time	D[15..0]	$t_{dst}$	CL Max. 30 pF Min. 8 pF	10	-
Data hold time		$t_{dht}$		10	-
Read access time (ID)		$t_{rat}$		-	40
Read access time (FM)		$t_{ratfm}$		-	340
Output disable time		$t_{odh}$		20	80

(5-6) Schematic of LCD module system

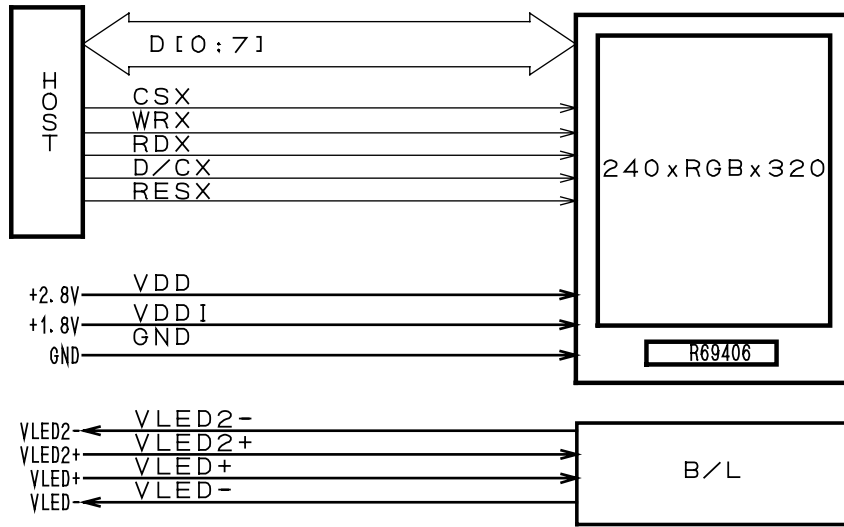

fig. 1 Schematic of LCD module system

( 5-7 ) Schematics of LCD

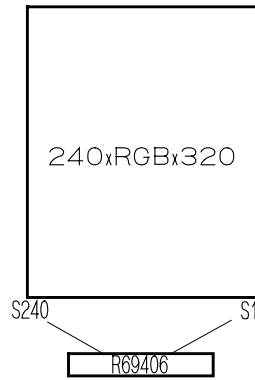

Fig.2 Schematic of Main-LCD



## 6. Optical Characteristics

VDD=2.8[V],VDDI=1.8[V],Ta=25[ ]

Table 10

Parameter		svmbo	Condition	MIN	TYP	MAX	Unit	Remark			
Transmissive mode	Brightness	B	$\theta=0^\circ$	T.B.D	(300)	-	cd/m <sup>2</sup>	Note1,2,5			
	Contrast	Cot	$\theta=0^\circ$	T.B.D	(350)	-		Note1,3			
	Flicker ratio	F	*1	-	-	(7.0)	%				
	NTSC ratio	Nrt	$\theta=0^\circ$	-	(80)	-	%	(u',v')			
	Viewing Angle	$\Theta$	Co > 5	$\Theta 11$	T.B.D	(80)	-	Deg	Note1		
				$\Theta 12$	T.B.D	(80)	-				
				$\Theta 21$	T.B.D	(80)	-				
				$\Theta 22$	T.B.D	(80)	-				
	White chromaticity	u'	$\theta=0^\circ$	-	(0.196)	-		Note1			
		v'		-	(0.467)	-					
	Red chromaticity	u		-	(0.433)	-					
		v'		-	(0.518)	-					
	Green chromaticity	u		-	(0.127)	-					
v'		-		(0.562)	-						
Blue chromaticity	u	-		(0.157)	-						
	v'	-		(0.170)	-						
Reflective mode	Reflectance	R		$\theta=0^\circ$	T.B.D	(4)			-	%	Note6
	Contrast	Cor		$\theta=0^\circ$	T.B.D	(45)			-		Note3,6
	NTSC ratio	Nrr	$\theta=0^\circ$	-	0	-	%				
	White chromaticity	u	$\theta=0^\circ$	-	(0.194)	-		Note.1			
v'		-	(0.490)	-							
Response Time	Rise	r	$\theta=0^\circ$	-	(25)	T.B.D	ms	Note1,4			
	Decay	d		-	(15)	T.B.D	ms				

\*1: Measuring condition

- Measuring systems: YOKOGAWA 3298\_01 + 3298\_11
- Temperature = 25 (± 3 ), Frame Frequency = 60Hz (-0/+5Hz), LED back-light: ON, Environment brightness < 150 lx
- Measuring pattern : Horizontal stripe pattern <black (V0) / gray(V32) / black (V0) / gray (V32)...>
- Measured sample : New sample before a long term aging.
- Flicker ratio is very sensitive to measuring condition.

Note 1) Definition of range of visual angle

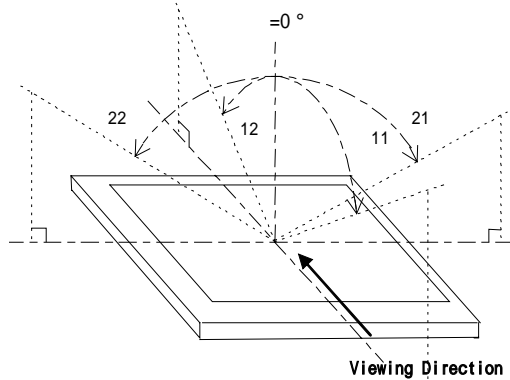

Fig.3 Definition of viewing angle

Note 2) Brightness is measured as shown in Fig.8, and is defined as the brightness of all pixels “White” at the center of display area on optimum contrast.

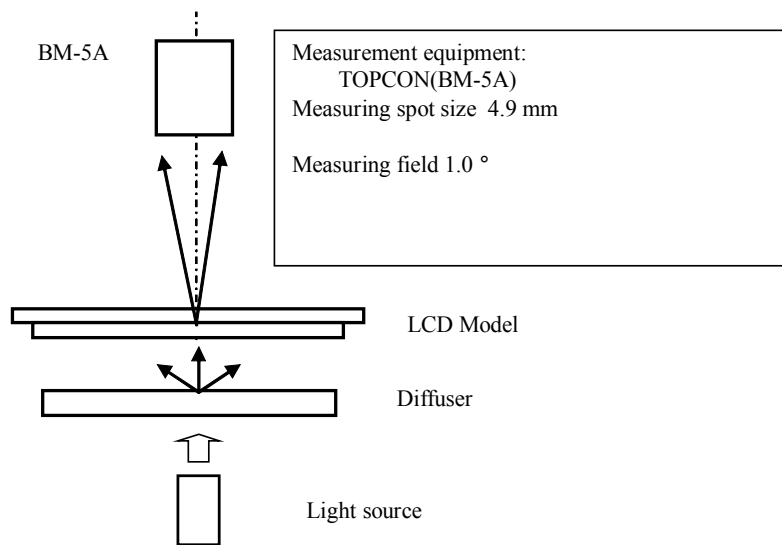

Fig4. Optical characteristics Test Method (Brightness)

Note 3) Contrast ratio is defined as follows:

$$Co = \frac{\text{Luminance(brightness) all pixels "White"}}{\text{Luminance(brightness) all pixels "Black"}}$$



Note 4) Response time is defined as follows:

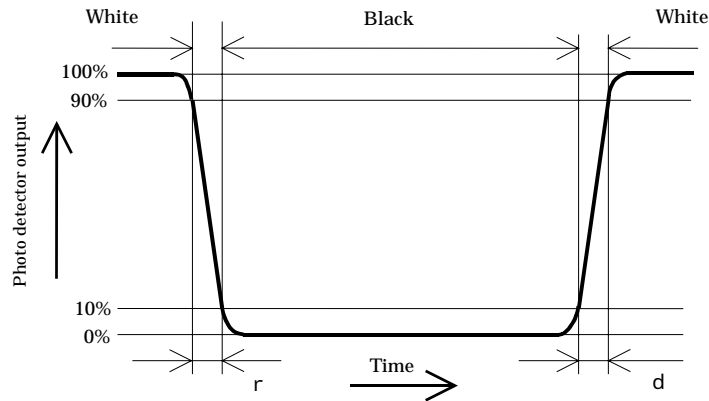

Fig.5 Response time

Note 5)  $I_{LED1} = 20[mA]$ ,  $I_{LED2} = 20[mA]$

Note 6) Reflectance is defined as follows:

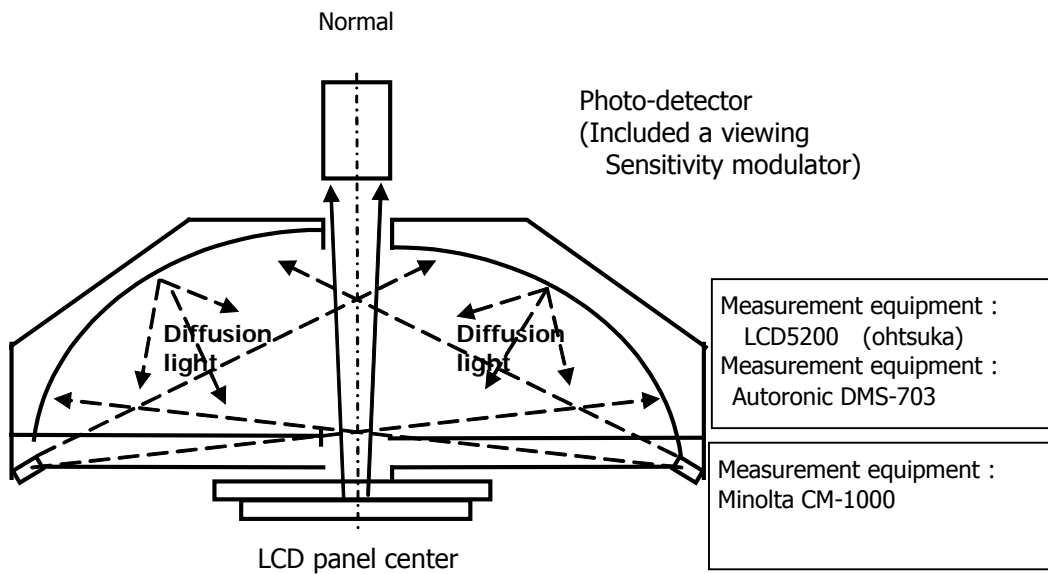

Fig. 8 Optical Characteristics Test Method

## 7. Reliability

(T.B.D.)

## 8. Packaging specifications

(T.B.D.)

## 9. Initial Sequence

### 9-1. Power On/Off Sequence

#### PowerOn

No.	Instruction	Setting Value	ADS (RS)	Register	Parameter	Remarks
1	Power ON (VDD 2.8[V],VDDI 1.8[V])					
2	Power will be stable					
3	Hardware Reset	RESX="H"->"L"				
	wait 1ms					
		RESX="L"->"H"				
	wait 5ms					
3	Software Reset	Software Reset	L	01		
	wait 5ms					
4	Sleep Out	Sleep Out	L	11		
	wait 120ms					
5	TE On	TE On	L	35		
			H	00		
6	Display data write to VRAM	Display memory write	L	2C		
					VRAM write	
7	Display On	Display On	L	29		

#### PowerOff

No.	Instruction	Setting Value	ADS (RS)	Register	Parameter	Remarks
1	Display Off	Display Off	L	28		
		Sleep IN	L	10		
	wait 120ms					
2	Hardware Reset	RESX="H"->"L"				
	wait 5ms					
3	Power Off (VDD 2.8[V],VDDI 1.8[V])					

## 9-2. Partial On/Off Sequence

### Example for Low Power Partial Mode On

No.	Item	Setting Value	ADS (RS)	Register	Parameter	Remarks
1	<b>Partial mode ON</b>					
		Partial mode ON	L	12		
		Partial Area setting	L	30		
		Area Start line	H		(00)	*example for 48 line partial
			H		(91)	
		Area End line	H		(00)	
			H		(BF)	
2	<b>Idle mode ON</b>					
		Idle mode ON	L	39		for 8 color mode
3	<b>Display data write to VRAM</b>					
		Display memory write	L	2C		
					VRAM write	

### Example for Low Power Partial Mode Off

No.	Item	Setting Value	ADS (RS)	Register	Parameter	Remarks
1	<b>Idle mode Off</b>					
		Idle mode Off	L	38		for normal color mode
2	<b>Partial mode Off</b>					
		Partial mode Off	L	13		

10. Serial Number Label identification  
(T.B.D)

11. LCD Module Code Rule.  
(T.B.D)

## 12. Module Outline

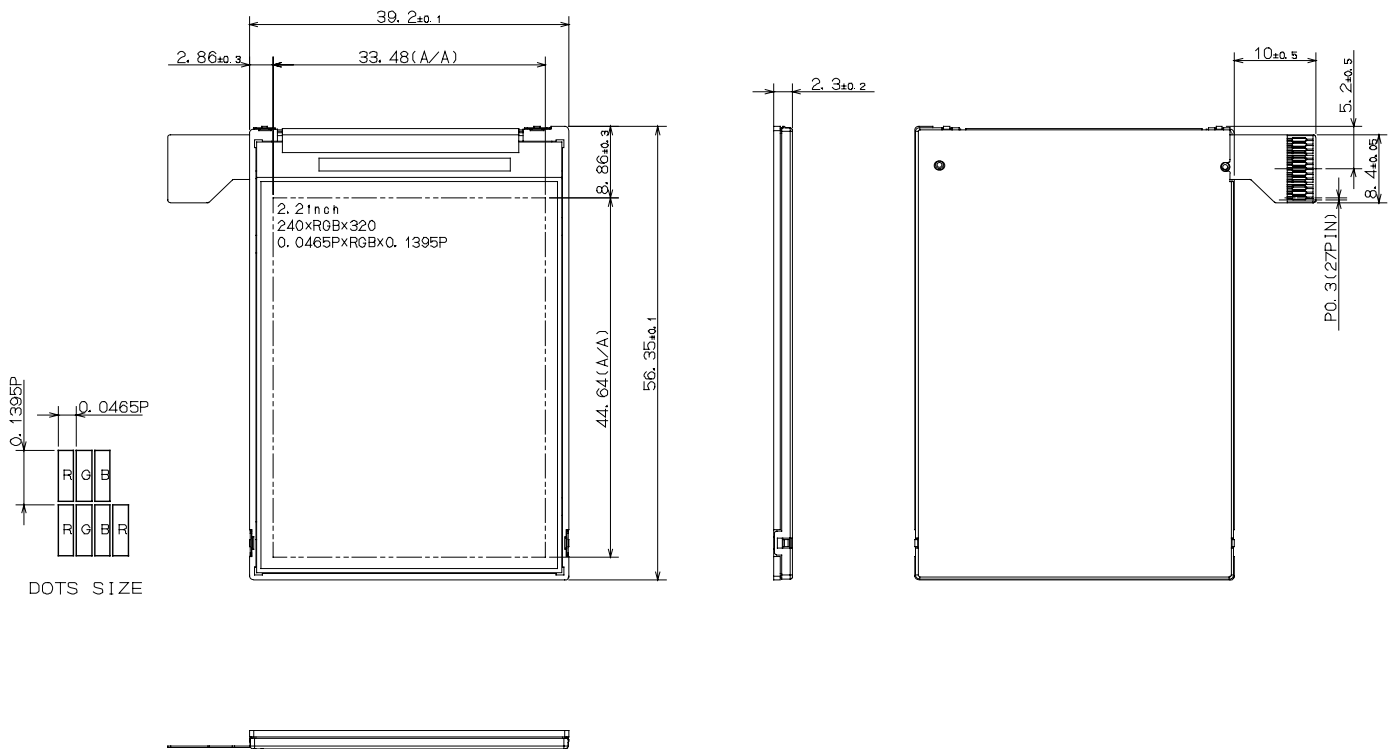

TO:	<p style="text-align: center;"><b>SHARP</b></p> <p style="text-align: center;">Mobile Liquid Crystal Display Group SHARP CORPORATION</p> <p style="text-align: center;">Incoming Inspection Standards</p>		
		ISSUE	
		File No.	
		Page	11 pages

Incoming Inspection Standards for CG-SiliconTFT-LCD

LS022Q8UX05

Customer's Receipt

Date \_\_\_\_\_

BY \_\_\_\_\_

PRESENTED  
BY \_\_\_\_\_

Mobile Liquid Crystal Display Group II  
SHARP CORPORATION

RECORDS OF REVISION		First issue	
		First File No.	
		Model	LS022Q8UX05
DATE	REVISED	SUMMARY	Check & APPROVAL

**INCOMING INSPECTION STANDARDS FOR CG-silicon TFT-LCD MODULES**

**1. Scope**

These incoming inspection standards shall apply to **CG-silicon** TFT-LCD modules (hereinafter called "MODULE") supplied by Sharp Corporation (hereinafter called the "Seller") to \_\_\_\_\_ (hereinafter called the "Buyer").

**2. Incoming inspection**

The Buyer shall have the right to conduct at its own cost and expense, an incoming inspection of the Module's at the destination specified in the relevant bills of lading in accordance with the Module's specifications separately agreed upon and the inspection standard set forth in this Article.

The Buyer shall notify the Seller writing of a result of such inspection judgment (acceptance or rejection) in accordance with the said inspection standard within 40 days after the date of the bills of lading.

Should the Buyer fail to so notify the seller within the said 40 days period, the Buyer's right to reject the Module's shall then lapse, and the said Module's shall be deemed to have been accepted by the Buyer.

**3. Method of incoming inspection**

Unless otherwise agreed in writing, the method of incoming inspection shall be in Accordance with a sampling inspection based on ISO 2859-1.

- a) Lot size : Quantity per shipment lot per model
- b) Sampling type : Normal inspection, Single sampling
- c) Inspection level : II
- d) Sampling table : Table in ISO 2859-1

**4. Acceptable quality level ("AQL")**

The AQL for major and minor defects shall be respectively set forth below.

- a) Major defects : AQL 0.4
- b) Minor defects : AQL 1.0 Based on overall evaluation

**5. Classification of defects**

Defects are classified as major defect and a minor defect according to the degree of defect defined herein.

- a) Major defect

A major defect is a defect that is likely to result in failure, or to reduce materially the usability of the product for its intended purpose.

Function defect

Abnormal operation including distinct R,G,B line defects and /or white line defect.



b) Minor defect

A minor defect either is a defect that is not likely to reduce materially the usability of the product for its intended purpose, or is a departure from an established having little bearing on the effective use or operation of the product.

- |                           |                        |
|---------------------------|------------------------|
| 1. Dot Defect             | 5. Scratches           |
| 2. Display non-uniformity | 6. Dents               |
| 3. Afterimage             | 7. Contrast ratio      |
| 4. Extraneous substances  | 8. Current dissipation |

**6. Determination of acceptability and subsequent disposal**

If the number of defects found in the sample Module's from the lot is equal to or less than the applicable acceptance level, the lot shall be accepted.

If the number of defects is greater than the applicable acceptance level, the lot shall be rejected. The Buyer shall inform the Seller of a detailed result of such inspection within the time period stipulated in Article 2.

The disposal is as follows :

a) Accepted lot

An acceptance under the above incoming inspection shall constitute an acceptance by the Buyer of such lot of the Module's in terms of the landed quality thereof.

b) Rejected lot

If a lot of PRODUCTS is rejected under the above incoming inspection due to any defects for which the Seller is responsible and such a fact is clearly confirmed by the Seller, the Seller shall exercise one of the following three options. This must be determined with mutual consent and shall be confirmed by the Seller. The best choice of the options shall be left to the Seller's discretion and the Seller shall advise the Buyer of its choice not later than two weeks of receipt of the Buyer's advice :

1. The Buyer shall return the defective lot to the place to be designated by the Seller and the Seller shall screen all of the PRODUCTS in the lot and repair defective PRODUCTS.
2. The Seller shall screen all of the PRODUCTS in the lot and repair defective products within a reasonable time period at the Buyer's facility.
3. The Buyer shall screen the entire lot for the good modules at the expense of the Seller to be separately agreed upon. The rejected PRODUCTS shall be returned to the place to be designated by the Seller

**7. Inspection conditions**

Item	Inspection conditions	
	Reflection inspection	Back light inspection
Panel surface illumination	2500 ± 500 lx (uniform lighting on the panel surface)	Back light *
Light source	Florescent tube	LED (Back light)
Ambient illumination	300 ~ 700 lx	←
Ambient temperature	20 ~ 25 °C	←
Ambient Humidity	65 ± 5%RH	←
Viewing distance	350 mm ± 50 mm	←
Direction of lighting	Set light tube without reflection on the panel surface	—
Viewing angle	The surface of the Module and the eyes of the inspector shall be 90 ± 5 degrees.	←
How to use ND filter	Use ND filter close to eyes (fig.1)	Use ND filter open to eyes (fig.2)
Check pattern (Bright dot)	Black picture position	←
Check pattern (Black dot)	RGB picture position	←

\* Please refer to the panel surface brightness of the specifications

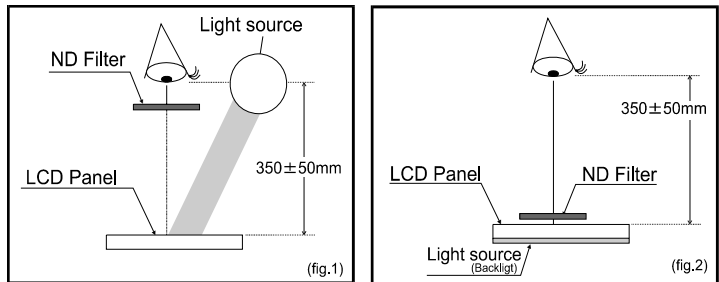

**8. External inspection**

8-1 Extraneous Substances, Polarizer bubble, Scratch

Width : W(mm) , Length : L(mm) , Average diameter : D(mm)

Item	Inspection criteria	Allowable	note
Black or white spots	$D \leq 0.15$	ignore	A,B
	$0.15 < D \leq 0.25$	2	
	$D > 0.25$	0	
Defect distance : 5mm or more			
Lints*1	$L \leq 0.15$	ignore	A
	$0.15 < L \leq 2.0$	2	
	$L > 2.0$	0	
Defect distance : 5mm or more			
Scratch	$L \leq 2.0$	ignore	A,B
	$2.0 < L \leq 3$ and $W \leq 0.1$	1	
		0	

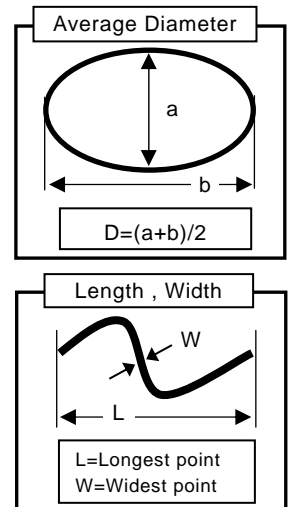

Item	Inspection criteria	Allowable	note
Polarizer	$D \leq 0.15$	ignore	A
Dent	$0.15 < D \leq 0.3$	3	
Polarizer Bubble	$< 0.3$	0	

\*1 Extraneous substances

\*Please refer to specifications for the inspection area of the externals inspection.

**Note:inspection condition;** judgement in each screen

Item	condition A	condition B
Panel surface illumination	$2500 \pm 500\text{lx}$ (external lighting source)	Use Back light *2
Ambient illumination	300 to 700lx	
Viewing distance	$350\text{mm} \pm 50\text{mm}$	
Check pattern	Module non operation	White or Black picture position

\*2 Please refer to the panel surface brightness of the description specifications.

8-2 Glass edge crack / chip

Items	Inspection criteria (Acceptable level)	note
Chip on glass corner (Part A)	$L \leq 5\text{mm}$ , $D \leq 1\text{mm}$ $L + D \leq 5\text{mm}$ *BM (black mask) is not affected.	Fig.1-A fig.2
Chip on the terminal glass (Part B)	$L \leq 3\text{mm}$ , $D \leq 3\text{mm}$ *FPC and patterns are not affected	fig.1-B fig.2
Chip on glass edge	$L \leq 10\text{mm}$ , $D \leq 1\text{mm}$ *BM (black mask) is not affected	fig.3

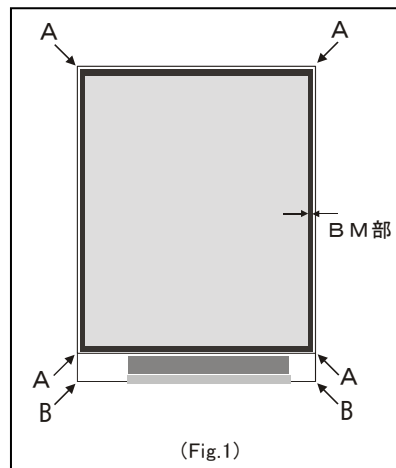
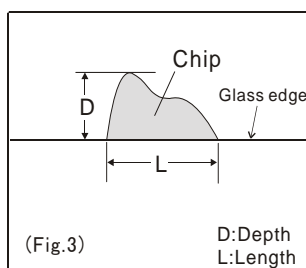
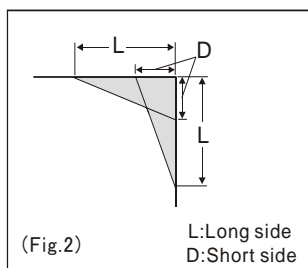

8-3 Parts assembly

8-3-1 Parts alignment

(a) Flat packaged LSI, IC

Locate 2/3 or more of the widths of the lead on the pattern pad.

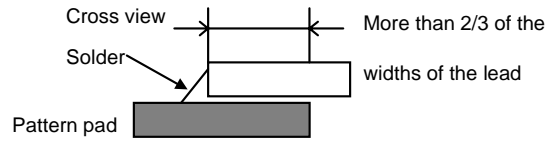

(b) Chip component

Locate 2/3 or more of the widths of the electrode on the pattern pad.

Locate the entire electrode on the pattern pad, If the width of pattern pad is narrower than component electrode.

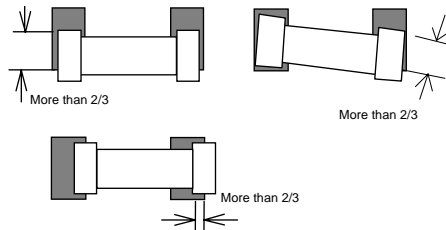

8-3-2 Height of components

The installation floatages of the chip components must be less than 0.5mm from the FPC pad.

Individual regulations give priority when individual regulations exist on specified drawings

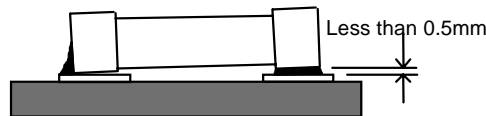

8-3-3 Damaged electrode of chip components

Do not expose the inside. Do not allow the crack.

Peeling off of the electrode plating must be less than 10% of the area of the electrode.

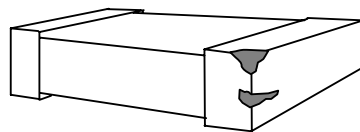

8-3-4 FPC electrode peeling off (floatage)

The electrode (FPC pattern) must not peel off from the FPC substrate.

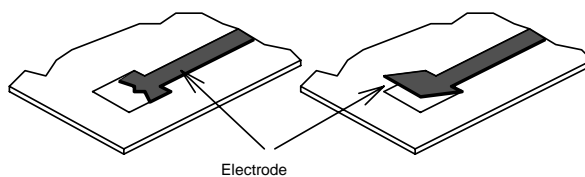

**8-3-5 Damaged FPC pattern**

The width of pinhole and/or loss of FPC pattern must be less than 1/2 of pattern width.

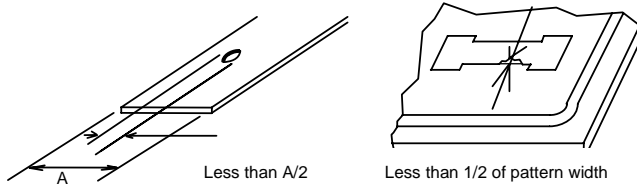

**8-3-6 Damaged plating of FPC**

The width of pinhole and/or loss of FPC pattern must be less than 1/3 of pattern width

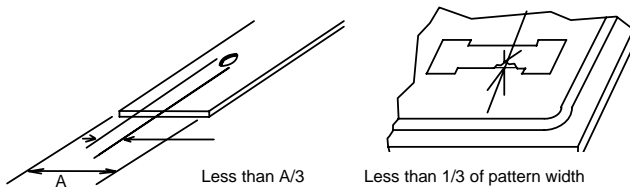

**8-3-7 FPC resist separation**

FPC pattern which not soldered must be coated by resist.

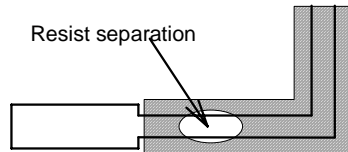

**8-3-8 Conductive foreign material**

Conductive foreign material of length which exceeds 0.30mm must not adhere on the module even if the length of foreign materials is less than 0.30mm , adhering on leads of IC and LSI is not acceptable

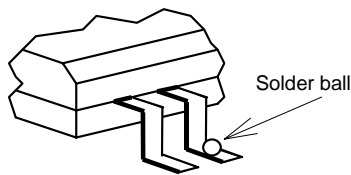

**9. Visual inspection**

**9-1 Zone**

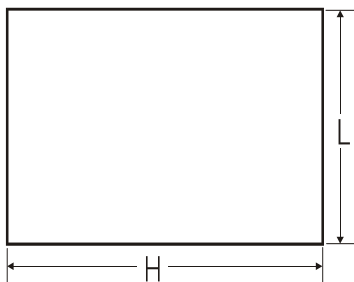

\* Please refer to the effective display area (active area)  
of specification about H,L

9-2 Definition

No	Item		Definition
a	Dot	Pixel	3 sub-pixels (R+G+B)
		Dot	1 sub-pixel (R or G or B)
b	Bright dot * (caused by TFT failure)	When the Module lights, dot appear bright in display at Black picture position.	
		Count	Visible through 5% ND filter
		Ignore	Not visible through 5% ND filter
c	Black dot * (caused by TFT failure)	When the Module lights, dot appear black in display at white picture position	
d	Scratch on the color filter	Count as bright dot	Visible over the half of a dot
		Ignore	Visible under the half of a dot
e	Scratch on the Cr mask	Count as bright dot	Visible over ø50 µm
		Ignore	Visible under ø50 µm

\* Regarding Black dot caused by Extraneous Substances, Polarizer bubble and/ or Scratch, "External inspection criteria" should be applied to them. (Please see section 8-1)

9-3 Number of Dot Defects(Bright dot+Black dot)

Item	Not of dot defects
Bright dots	1
Black dots	3
Total(Bright dots+Black dots)	3

9-4 Defect distance & join

Item		Inspection criteria
Defect distance	Bright dots	5 mm or more
	Black dots	5 mm or more
Joined dots	Bright dots	Not allowed
	Black dots	Connection of a black dot is permitted to two dots
	3 dots or more	Not allowed

\*It is considered that the joined black dot is one black dot.

**10. Display non-uniformity**

There should be no distinct non-uniformity visible through 2% ND filter.

**11. Others**

If some problems arise about mentioned items in this document and other items, the user of the TFT-LCD module and Sharp will cooperate and make efforts to solve the problems with mutual respect and good will.