

|      |              |
|------|--------------|
| No.  | LCP2111038A  |
| Date | Aug 11, 2011 |

***Technical Literature***  
***For***  
***TFT-LCD Module***

***Model No. LS044Q7DH01***

Notice

The technical Literature is subject to change without any prior notice for the purpose of product improvement. Please contact Sharp or its representative before designing your product based on this literature.

Display Device Business Group  
SHARP CORPORATION



|                                |                                 |                  |
|--------------------------------|---------------------------------|------------------|
| SPEC No.<br><b>LCP2111038A</b> | MODEL No.<br><b>LS044Q7DH01</b> | PAGE<br><b>1</b> |
|--------------------------------|---------------------------------|------------------|

## NOTICE

### <<Precautions>>

○ These specification sheets are the proprietary product of SHARP CORPORATION ("SHARP") and include materials protected under copyright of SHARP. Do not reproduce or cause any third party to reproduce them in any form or by any means, electronic or mechanical, for any purpose, in whole or in part, without the express written permission of SHARP.

○ The application examples in these specification sheets are provided to explain the representative applications of the device and are not intended to guarantee any industrial property right or other rights or license you to use them.

○ Observe the following points when in using any device in this publication. SHARP takes no responsibility for damage caused by improper use of the devices.

The devices in this publication are designed for use in general electronic equipment designs, such as:

- Personal computers
- Office automation
- Telecommunication equipment
- Test and measurement equipment
- Industrial control
- Audio visual and multimedia equipment
- Consumer electronics

The appropriate design measures should be taken to ensure reliability and safety when SHARP's devices are used for equipment such as:

- Transportation control and safety equipment(i.e.,aircraft,trains,automobiles,etc.)
- Traffic signals
- Gas leakage sensor breakers
- Alarm equipment
- Various safety devices etc.

○ SHARP's devices shall not be used for equipment that requires extremely high level of reliability, such as:

- Military and space applications
- Nuclear power control equipment
- Medical equipment for life support

○ SHARP assumes no responsibility for any damage resulting from the use of the device which does not comply with the instructions and the precautions specified in these specification sheets.

## [For handling and system design]

- (1) Handle with care as glass is used in this LCD panel. Dropping or contact against hard object may cause cracks or chips.
- (2) Be careful to handle this LCD panel in order to avoid injury yourself by panel's edge as this panel is made of glass and might be a sharp edge.
- (3) Do not scratch the surface of the polarizer as it is easily damaged.
- (4) Water droplets on the polarizer must be wiped off immediately as they may cause color changes, or other defects if remained for a long time.
- (5) Do not leave the LCD panel in direct sun or under ultraviolet ray.
- (6) To clean LCD panel surface, wipe clean with absorbent cotton or soft cloth. If further cleaning is needed, use IPA (isopropyl alcohol) and wipe clean lightly on surface only. Do not use organic solvents as it may damage the LCD panel terminal area which uses organic material. Also, do not directly touch with finger. When the terminals cleaning are needed, those should be wiped by a soft cloth or a cotton swab without directly touching by hand.
- (7) Do not expose gate driver, etc. on the panel (circuit area outside panel display area) to light as it may not operate properly. Design that shields gate driver, etc. from light is required when mounting the LCD module.
- (8) To avoid circuit failure, do not touch panel terminal area.
- (9) Support for the LCD panel should be carefully designed to avoid stress that exceeds specification on glass surface.
- (10) When handling LCD module and assembling them into cabinets, be noted that storage in the environment of oxidization or deoxidization gas and the use of such materials as reagent, solvent, adhesive, resin, and etc. which generate these gasses, may cause corrosion and discoloration of LCD modules.
- (11) To avoid picture uniformity failure, do not put a seal or an adhesive material on the panel surface.
- (12) Do not use chloroprene rubber as it generates chlorine gas and affects reliability in LCD panel connective area.
- (13) Protective film is attached to the surface of polarizer on LCD panel to prevent scratches or other damages. Remove this protective film before use. In addition, do not attach the protective film which is removed from LCD module again. When the LCD panel which has the reattached protective film is needed to storage for a long time, the polarizer might have a damage with picture quality failure.
- (14) Panel is susceptible to mechanical stress and such stress may affect the display. Place the panel on flat surface to avoid stress caused by twist, bend, etc.
- (15) When transporting LCD panels, secure them in LCD panel tray to avoid mechanical stress. The tray should be conductive to protect LCD panels from static charge.  
Material used in set or epoxy resin (amine type hardening agent) from packaging, and silicon adhesive (dealcoholized or oxime) all release gas which may affect quality of the polarizer. Do confirm compatibility with user materials.
- (16) As this LCD module is composed electronic circuits, it is sensitive to electrostatic discharge of 200V or more. Handle with care using cautions for the followings:
  - Operators  
Operators must wear anti-static wears to prevent electrostatic charge up to and discharge from human body.

- Equipment and containers

Process equipment such as conveyer, soldering iron, working bench and containers may possibly generate electrostatic charge up and discharge. Equipment must be grounded through 100Mohms resistance. Use ion blower.

- Floor

Floor plays an important role in leaking static electricity generated in human body or equipment. If the floor is made of insulated material (such as polymer or rubber material), such static electricity may charge. Proper measure should be taken to avoid static electricity charge (electrostatic earth: 100Mohms). There is a possibility that the static electricity is charged to them without leakage in case of insulating floor, so the electrostatic earth:  $1 \times 10^8 \Omega$  should be made.

- Humidity

Humidity in work area relates to surface resistance of the persons or objects that generate electrostatics, and it can be manipulated to prevent electrostatic charge. Humidity of 40% or lower increases electrostatic earth resistance and promotes electrostatic charging. Therefore, the humidity in the work area is recommended to be kept above 40%. Specifically for film peeling process or processes that require human hands, humidity is recommended to be kept above 50% and use electricity removal blower.

- Transportation/Storage

Containers and styrofoam used in transportation and storage may charge electrostatic (from friction and peeling) or electrostatic charge from human body, etc. may cause containers and styrofoam to have induced charge. Proper electrostatic measure should be taken for containers and storage material.

### [For operating LCD module]

- (1) Do not operate the LCD panel under outside of electrical specification. Otherwise LCD panel may be damaged.
- (2) Do not use the LCD panel under outside of specified driving timing chart. Otherwise LCD panel may not have proper picture quality.
- (3) In order to prevent image retention it is our recommendation that an inverted display image (preferred) or white pattern be introduced as a refresh at a minimum for 1hour over a 24 hour period. In refreshing, display can be written white image by addressing white data as normal driving for this panel or DISP signal would be set as "Low".
- (4) If LCD module takes a static electricity, as the display image which is written into pixel memory might not be displayed, Data update should be executed frequently.
- (5) It is neither a breakdown nor a defective indication though very slight change in black level might be periodically seen in a black part on the black display image according to the source of light (angle of the luminance and the source of light).

### [Precautions for Storage]

- (1) After opening the package, do not leave the LCD panel in direct sun or under strong ultraviolet ray. Store in dark place.
- (2) In temperature lower than specified rating, liquid crystal material will coagulate. In temperature higher than specified rating, it isotropically liquifies. In either condition, the liquid crystal may not recover its original condition. Store the LCD panel in at or around room temperature as much as possible.  
Also, storing the LCD panel in high humidity will damage the polarizer. Store in normal room temperature as much as possible.

#### (3) Keeping Method

a. Don't keeping under the direct sunlight.

b. Keeping in the tray under the dark place.

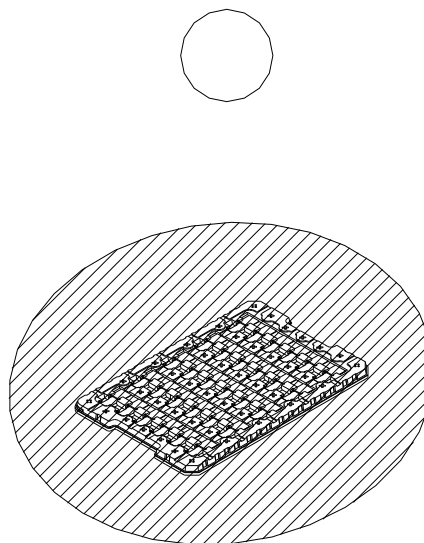
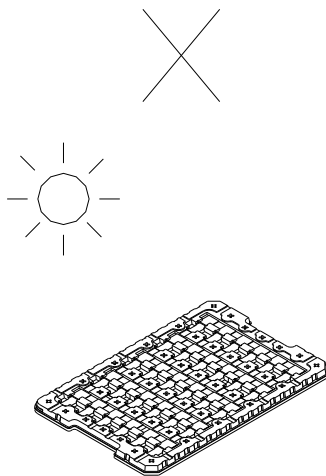

### [Other Notice]

- (1) Operation outside specified environmental conditions cannot be guaranteed.
- (2) As power supply (VDD-GND、VDDA-GND) impedance is lowered during use, bus controller should be inserted near LCD module as much as possible.
- (3) The polarizer is applied over LCD panel surface. Liquid crystal inside LCD panel deteriorates with ultraviolet ray. The panel should not be left in direct sun or under strong ultraviolet ray for prolonged period of time even with the polarizer film.
- (4) Disassembling the LCD module will cause permanent damage to the module. Do not disassemble the module.
- (5) If LCD panel is broken, do not ingest the liquid crystal from the broken panel. If hand, leg, or clothes come in contact with liquid crystal, wash off immediately with soap.
- (6) ODS (specific chlorofluorocarbon, specific halon, 1-1-1 trichloroethane, carbon tetrachloride) are not used or contained in material or all production processes of this product.
- (7) Observe all other precautionary requirements in handling general electronic components.

### [Discarding liquid crystal modules]

LCD Panel : Dispose of as glass waste. This LCD module contains no harmful substances.

The liquid crystal panel contains no dangerous or harmful substances.

This liquid crystal panel contains only an extremely small amount of liquid crystal (approximately 100mg) and therefore it will not leak even if the panel should break.

Its median lethal dose (LD50) is greater than 2,000 mg/kg and a mutagenetic (Aims test: negative) material is used.

|                                |                                 |                  |
|--------------------------------|---------------------------------|------------------|
| SPEC No.<br><b>LCP2111038A</b> | MODEL No.<br><b>LS044Q7DH01</b> | PAGE<br><b>6</b> |
|--------------------------------|---------------------------------|------------------|

## Contents

|  |           |
|--|-----------|
| <b>1. Outline</b> .....                            | <b>7</b>  |
| <b>2. Characteristics</b> .....                    | <b>7</b>  |
| <b>3. Mechanical Specification</b> .....           | <b>7</b>  |
| <b>4. Input terminal names and functions</b> ..... | <b>8</b>  |
| <b>5. Absolute Maximum Rating</b> .....            | <b>9</b>  |
| <b>6. Electrical characteristics</b> .....         | <b>10</b> |
| <b>7. Optical characteristics</b> .....            | <b>21</b> |
| <b>8. Module outline</b> .....                     | <b>23</b> |
| <b>9. External capacitors</b> .....                | <b>24</b> |
| <b>10. External Power Supply Circuit</b> .....     | <b>25</b> |
| <b>11. Packaging</b> .....                         | <b>26</b> |
| <b>12. Reliability Test Conditions</b> .....       | <b>28</b> |



## 1. Outline

This TFT-LCD module is a HR-TFT reflective with slightly transmissive active matrix memory liquid crystal display module with CG silicone thin film transistor. Module outline is indicated in fig 8-1.

## 2. Characteristics

- 4.4" QVGA monochrome HR-TFT reflective with slightly transmissive panel
- Transmissive mode is available by implementation with backlight. (Transmittance is around 0.25%)
- 320x240 dot stripe arrangement
- Display control with serial data signal communication
- Arbitrary gate line is selectable to data update
- Internal 1bit memory within the panel for data memory
- Thin, light and compact module with monolithic technology
- Super low power consumption TFT panel
- With FPC (Applicable connector: Refer to recommended connector on page 23.)

## 3. Mechanical Specification

Table 3-1

| Item              | Specification                  | unit            |
|-------------------|--------------------------------|-----------------|
| Screen size       | 11.09 (4.4")                   | cm              |
| Active Area       | 89.6 (H) × 67.2 (V)            | mm              |
| Viewing Area      | 90.8(H) × 68.4 (V)             | mm              |
| Dot configuration | 320 x 240                      | Dot             |
| Dot pitch         | 0.280 (H) × 0.280 (V)          | mm              |
| Pixel Array       | Stripe Array                   | -               |
| Outline Dimension | 94.8 (W) × 75.2 (H) × 1.64 (D) | mm              |
| Mass              | Approximate 26                 | g               |
| Surface Hardness  | 3H                             | Pencil hardness |

(Note) Detail dimension and tolerance are shown in fig. 8-1

The FPC shape isn't included in the outline dimension.

There are the dummy area which is white partten as 0.6mm width around display area in viewing area.

## 4. Input terminal names and functions

Table4-1

| Terminal | symbol   | I/O   | Function  | Remark      |
|----------|----------|-------|---|-------------|
| 1        | SCLK     | INPUT | Serial clock signal                             |             |
| 2        | SI       | INPUT | Serial data input signal                        |             |
| 3        | SCS      | INPUT | Chip select signal                              |             |
| 4        | EXTCOMIN | INPUT | External COM inversion signal input (H: enable) |             |
| 5        | DISP     | INPUT | Display ON/OFF signal                           | 【Remark4-2】 |
| 6        | VDDA     | POWER | Power supply (Analog)                           |             |
| 7        | VDD      | POWER | Power supply (Digital)                          |             |
| 8        | EXTMODE  | INPUT | COM inversion select terminal                   | 【Remark4-1】 |
| 9        | VSS      | GND   | GND(Digital)                                    |             |
| 10       | VSSA     | GND   | GND(Analog)                                     |             |

【Remark4-1】When it's "H", EXTCOMIN signal is enable. And when it's "L", serial input flag is enable.

"H" mode; connect the EXTMODE to VDD, "L" mode; connect the EXTMODE to VSS.

【Remark4-2】The display ON/OFF signal is only for display. Data in the memory will be saved at the time of ON/OFF.

When it's "H", data in the memory will display, when it's "L", white color will display and data in the memory will be saved.

4-2) Recommended circuit;

COM Signal Serial Input  
EXTMODE=L

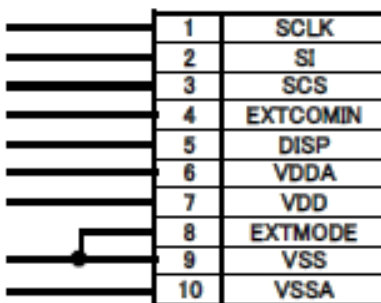

External COM Signal Input  
EXTMODE=H

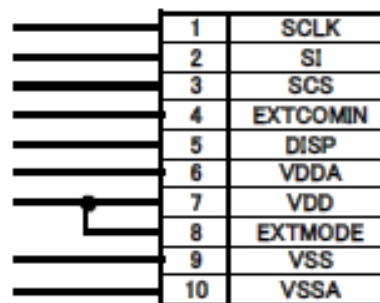

|                                |                                 |                  |
|--------------------------------|---------------------------------|------------------|
| SPEC No.<br><b>LCP2111038A</b> | MODEL No.<br><b>LS044Q7DH01</b> | PAGE<br><b>9</b> |
|--------------------------------|---------------------------------|------------------|

## 5. Absolute Maximum Rating

Table 5-1 (GND=0V)

| Item  |                     | Code  | MIN. | MAX. | Unit | Remark         |
|---|---------------------|-------|------|------|------|----------------|
| Power supply Voltage                              | Analog Power Supply | VDDA  | -0.3 | +5.8 | V    |                |
|   | Logic Power Supply  | VDD   | -0.3 | +5.8 | V    | 【Remark 5-1】   |
| Input signal terminal voltage (high)              |                     |       |      | VDD  | V    | 【Remark 5-2】   |
| Input signal terminal voltage (low)               |                     |       | -0.3 |      | V    |                |
| Storage temperature                               |                     | Tstg  | -30  | +80  | °C   | 【Remark 5-3,4】 |
| Operating temperature (Panel surface temperature) |                     | Topr1 | -20  | +70  | °C   | 【Remark 5-5】   |

【Remark 5-1】 Also applicable to EXTMODE.

【Remark 5-2】 Applicable to SCLK, SI, SCS, DISP, EXTCOMIN.

【Remark 5-3】 Do not exceed this rating in any area of the module.

【Remark 5-4】 Maximum wet-bulb temperature should be 57°C or lower. Do not allow condensation. Condensation may cause electrical leak and the module may not meet s specification.

【Remark 5-5】 Operating temperature is temperature that guarantess operation only. For contrast, response speed, and other display quty, module is evaluated at Ta=+25°C.

## 6. Electrical characteristics

### 6-1) TFT LCD panel drive

Table6-1 Recommended operating Condition

VSS(GND)=0V, Ta= +25°C

| Item                 | symbol | MIN. | TYP. | MAX. | Unit     | Remark |             |
|----------------------|--------|------|------|------|----------|--------|-------------|
| Power supply         | Analog | VDDA | +4.8 | +5.0 | +5.5     | V      |             |
|                      | Logic  | VDD  | +4.8 | +5.0 | +5.5     | V      | [Remark6-1] |
| Input signal voltage | Hi     | VIH  | +2.7 | +3.0 | VDD      | V      | [Remark6-2] |
|                      | Lo     | VIL  | VSS  | VSS  | VSS+0.15 | V      |             |

[Remark6-1] Applies to EXTMODE="H"

[Remark6-2] Applies to SCLK, SI, SCS, DISP, EXTCOMIN.

## 6-2) Power supply sequence

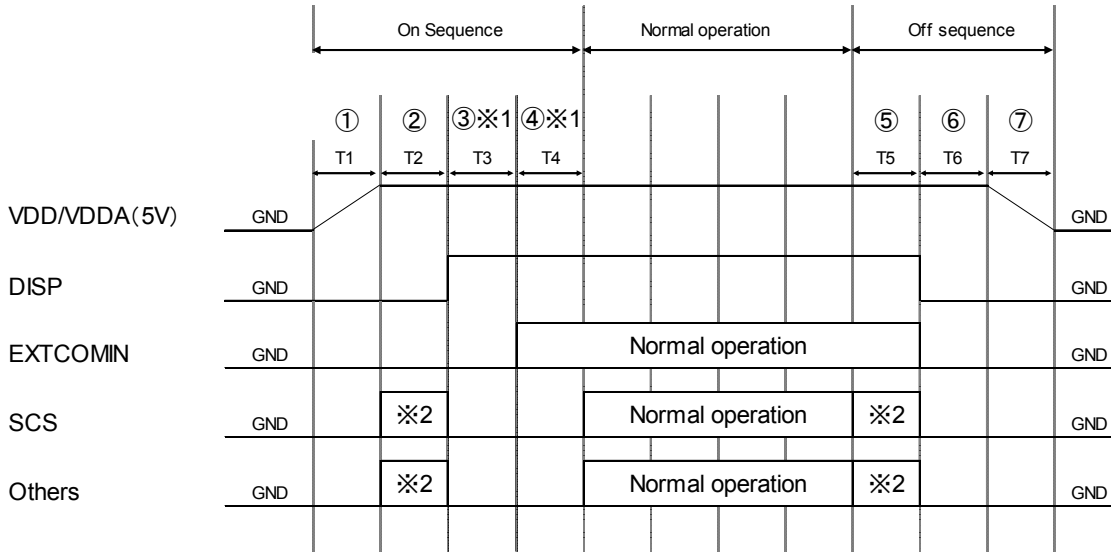

※Refer to timing chart and AC timing characteristics for detail

※1 ③ and ④ may be opposite (however, TCOM polarity inversion will not occur even with EXTCOMIN between DISP="L".) Also, when DISP and EXTCOMIN are simultaneously started up, allow 100us or more before SCS starts up (It may be less than 200us).

※2 Setting value for pixel memory initialization

SCS=Driving accordingly to clear pixel internal memory method (use all clear flag or write all screen white)

S1=M2 (all clear flag) = "H" or write white

SCLK: Normal Driving

### [ON Sequence]

(1) 5V rise time (depends on IC)

(2) Pixel memory initialization T2: 1V or more Initialize with M2 (all clear flag) or write all screen white

(3) Release time for initialization of TCOM latch T3: 100us or more

Time required to release COM related latch circuit initialization which is initializing using DISP signals

(4) TCOM polarity initialization time T4: 100us or more

Time required initializing TCOM polarity accordingly to EXTCOMIN input

### [Normal Operation]

Duration of normal driving

### [Off Sequence]

(5) Pixel memory initialization time T5: It is the same content as T2

(6) VA, VB, VCOM initialization time T6: 100us or more

(7) 5V falling time (Depends on IC)

### [Remark] Cautions when powering on

Remark 1) VDD and VDDA should rise simultaneously or VDD should rise first.

Remark 2) VDD and VDDA should fall simultaneously or VDD should fall first

### 6-3) Input signal characteristics

Table6-3-1 VDDA=+5.0V, VDD=+5.0V, GND=0V, Ta=25°C

| Item              | Symbol | MIN   | TYP | MAX  | Unit | Remark |
|-------------------|--------|-------|-----|------|------|--------|
| Frame frequency   | fSCS   | 1     | -   | 20   | Hz   |        |
| Clock frequency   | fSCLK  |       | 1   | 2    | MHz  |        |
| Vertical Interval | tV     | 50.00 | -   | 1000 | ms   |        |
| COM Frequency     | fCOM   | 0.5   | -   | 10   | Hz   |        |

Table 6-3-2 VDDA=+5.0V, VDD=+5.0V, GND=0V, Ta=25°C

| Item                         | Code       | MIN | TYP | MAX | Unit | Remark           |
|------------------------------|------------|-----|-----|-----|------|------------------|
| SCS rising time              | trSCS      |     |     | 50  | ns   |                  |
| SCS falling time             | tfSCS      |     |     | 50  | ns   |                  |
| SCS High width               | twSCSH     | 180 |     |     | us   | Data update mode |
|                              |            | 12  |     |     | us   | Display mode     |
| SCS Low width                | twSCSL     | 1   |     |     | us   |                  |
| SCS setup time               | tsSCS      | 3   |     |     | us   |                  |
| SCS hold time                | thSCS      | 1   |     |     | us   |                  |
| SI rising time               | trSI       |     |     | 50  | ns   |                  |
| SI falling time              | tfSI       |     |     | 50  | ns   |                  |
| SI set up time               | tsSI       | 120 |     |     | ns   |                  |
| SI hold time                 | thSI       | 190 |     |     | ns   |                  |
| SCLK rising time             | trSCLK     |     |     | 50  | ns   |                  |
| SCLK falling time            | tfSCLK     |     |     | 50  | ns   |                  |
| SCLK High width              | twSCLKH    | 200 | 450 |     | ns   |                  |
| SCLK Low width               | twSCLKL    | 200 | 450 |     | ns   |                  |
| EXTCOMIN signal frequency    | fEXTCOMIN  |     | 1   | 20  | Hz   | 【Remark 6-3】     |
| EXTCOMIN signal rising time  | trEXTCOMIN |     |     | 50  | ns   |                  |
| EXTCOMIN signal falling time | tfEXTCOMIN |     |     | 50  | ns   |                  |
| EXTCOMIN signal High width   | twEXTCOMIN | 1   |     |     | us   |                  |
| DISP rising time             | trDISP     |     |     | 50  | ns   |                  |
| DISP falling time            | tfDISP     |     |     | 50  | ns   |                  |

【Remark 6-3】 EXTCOMIN frequency should be made lower than frame frequency.

### SCS, SI, SCLK signal

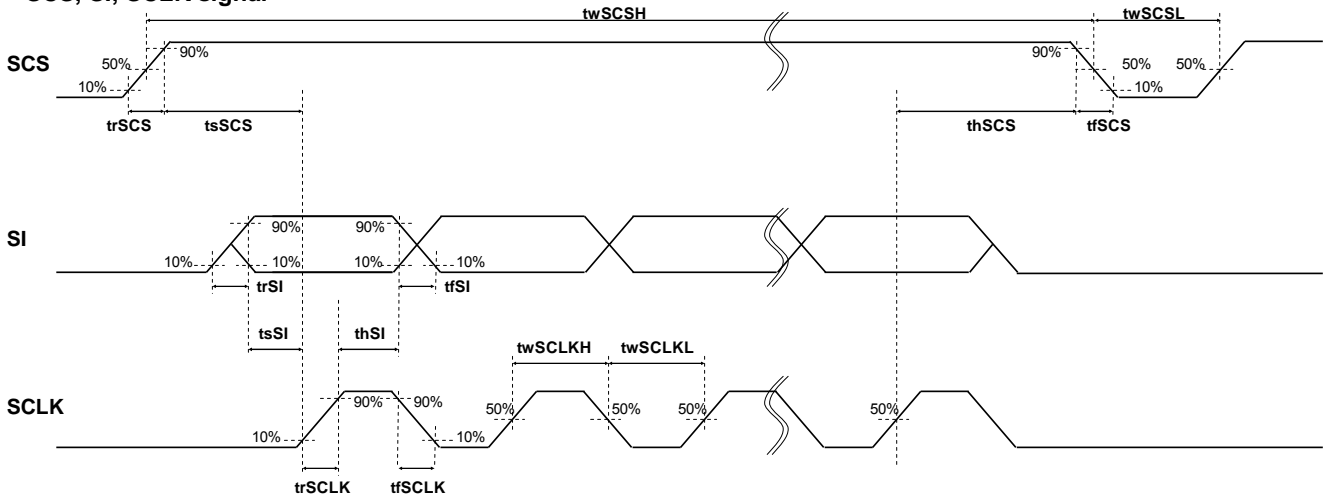

### EXTCOMIN signal

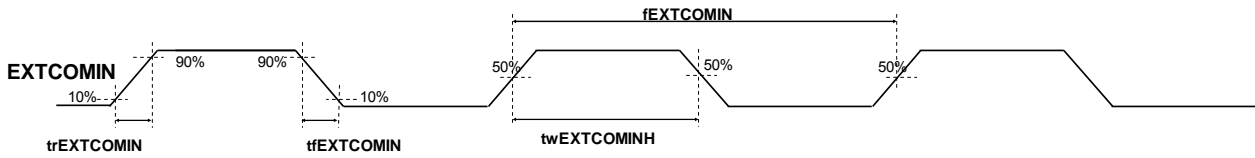

### DISP signal

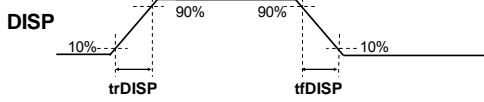

※SCS,SI,SCLK、DISP、EXTCOMIN: 3V input voltage

|                                |                                 |                   |
|--------------------------------|---------------------------------|-------------------|
| SPEC No.<br><b>LCP2111038A</b> | MODEL No.<br><b>LS044Q7DH01</b> | PAGE<br><b>14</b> |
|--------------------------------|---------------------------------|-------------------|

## 6-4) Power consumption (Average)

Table6-4

Ta=25°C

| Item       | Symbol | MIN | TYP   | MAX | unit | Remark      |
|------------|--------|-----|-------|-----|------|-------------|
| Condition1 |        |     | (250) |     | uW   | [Remark6-4] |
| Condition2 |        |     | (650) |     | uW   | [Remark6-4] |

### \* Measurement Condition 1

Display mode (no display data update), Display pattern: Vertical stripe display

### \* Measurement Condition 2

Data update mode (with display data update: 1Hz)

Common inversion with VDD=5V、VDDA=5V、fSCLK=1MHz、fSCS=1Hz, Display pattern: Vertical stripe display

**【Remark 6-4】** This is value in steady condition, not the value of peak power at the time of COM operation. Some margining for power supply is recommended. We recommend capacitor for VDD and VDDA. (If VDD and VDDA are on separate systems, we recommend capacitor for each.)



## 6-5) Input Signal Timing Chart

### 6-5-1 Data update mode (1 line)

Updates data of only one specified line. (M0="H", M2="L")

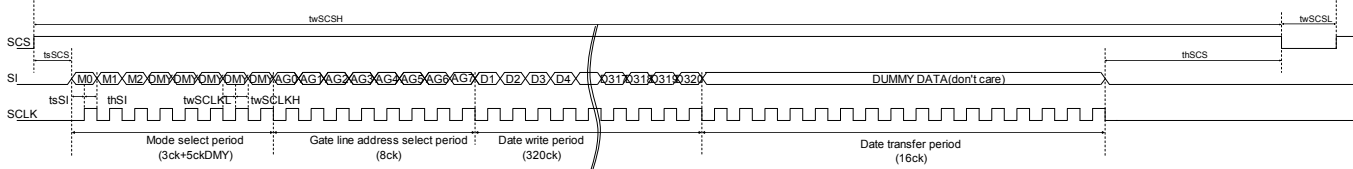

M0: Mode flag. Set for "H". Data update mode (Memory internal data update)

When "L", display mode (maintain memory internal data).

M1: Frame inversion flag.

When "H", outputs VCOM="H", and when "L", outputs VCOM="L".

When EXTMODE="H", it can be "H" or "L".

M2: All clear flag.

Refer to 6-5-4) All Clear Mode to execute clear.

DUMMY DATA: Dummy data. It can be "H" or "L" ("L" is recommended.)

※ Data write period

Data is being stored in 1<sup>st</sup> latch block of binary driver on panel.

※ Data transfer period

Data written in 1<sup>st</sup> latch is being transferred (written) to pixel internal memory circuit.

※For gate line address setting, refer to 6-6) Input Signal and Display.

※M1: Frame inversion flag is enabled when EXTMODE="L".

※When SCS becomes "L", M0 and M2 are cleared.

## 6-5-2 Data Update Mode (Multiple Lines)

Updates arbitrary multiple lines data. (M0="H", M2="L")

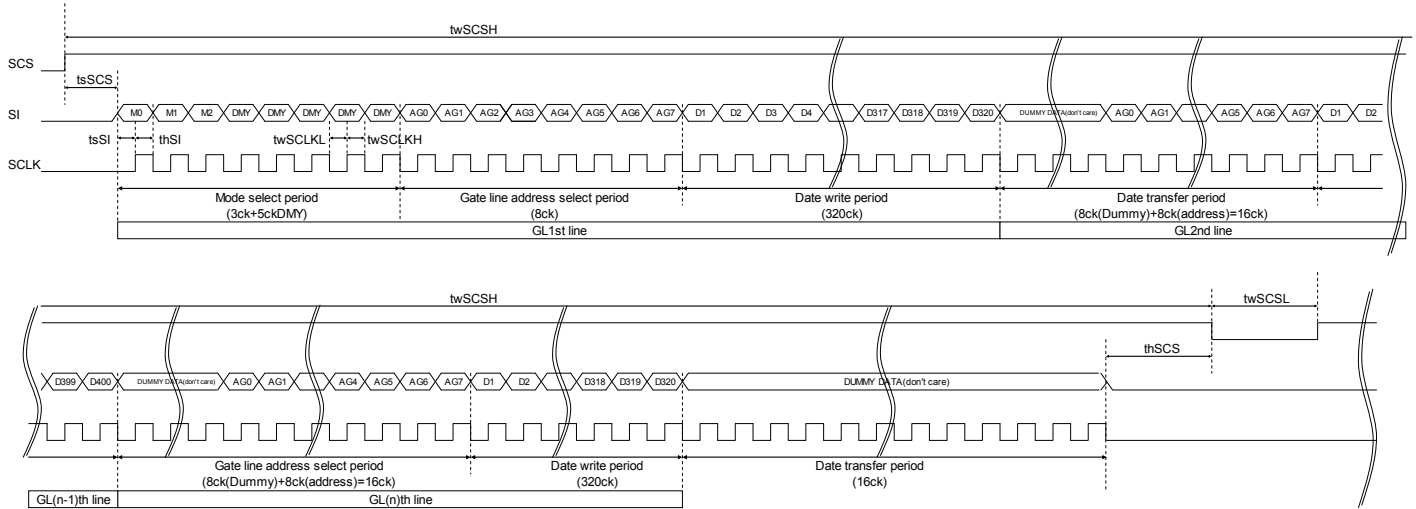

M0: Mode flag. Set for "H". Data update mode (Memory internal data update)  
When "L", display mode (maintain memory internal data).

M1: Frame inversion flag.  
When "H", outputs VCOM="H", and when "L", outputs VCOM="L".  
When EXTMODE="H", it can be "H" or "L".

M2: All clear flag.  
Refer to 6-5-4) All Clear Mode to execute clear.

DUMMY DATA: Dummy data. It can be "H" or "L" ("L" is recommended.)

- ※ Data write period  
Data is being stored in 1<sup>st</sup> latch block of binary driver on panel.
- ※ Data transfer period  
For example, during GL2<sup>nd</sup> line data transfer period, GL 2<sup>nd</sup> line address is latched and GL1<sup>st</sup> line data is transferred from 1<sup>st</sup> latch to pixel internal memory circuit at the same time.

※ For gate line address setting, refer to 6-6) Input Signal and Display.

※ Input data continuously.

※ M1: Frame inversion flag is enabled when EXTMODE="L".

※ When SCS becomes "L", M0 and M2 are cleared.

## 6-5-3 Display Mode

Maintains memory internal data (maintains current display). (M0="L", M2="L")

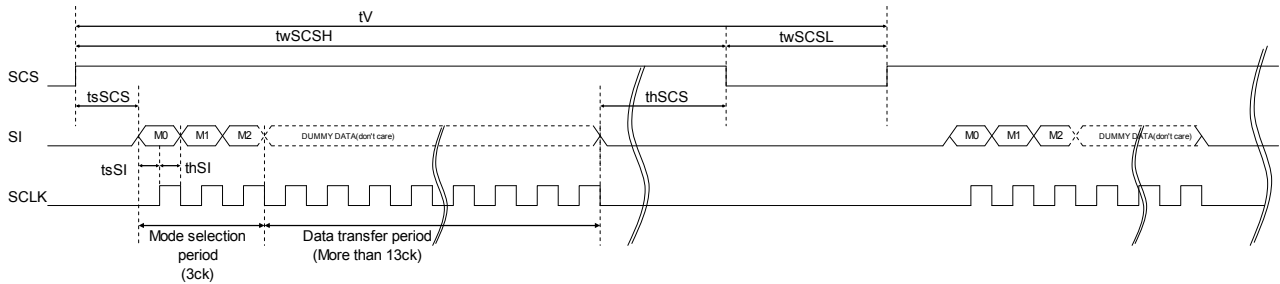

M0: Mode flag. Set for "H". Data update mode (Memory internal data update)  
When "L", display mode (maintain memory internal data).

M1: Frame inversion flag.  
When "H", outputs VCOM="H", and when "L", outputs VCOM="L".  
When EXTMODE="H", it can be "H" or "L".

M2: All clear flag.  
Refer to 6-5-4) All Clear Mode to execute clear.

DUMMY DATA: Dummy data. It can be "H" or "L" ("L" is recommended.)

※M1: Frame inversion flag is enabled when EXTMODE="L"

※When SCS becomes "L", M0 and M2 are cleared.

## 6-5-4 All Clear Mode

Clears memory internal data and writes white. (M0="L", M2="H")

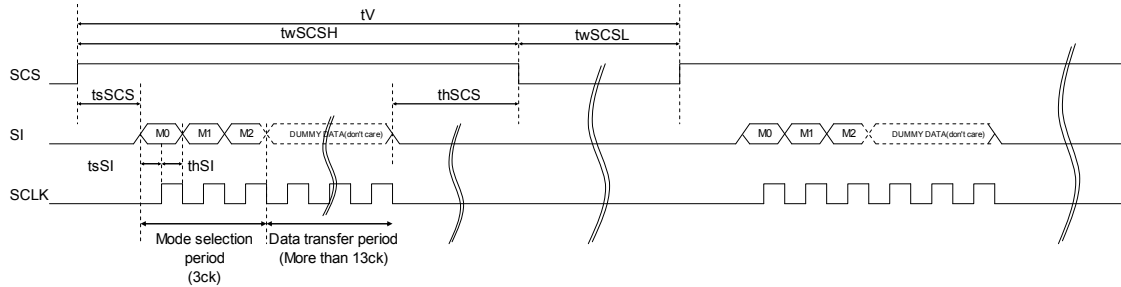

M0: Mode flag.

Set it "L".

M1: Frame inversion flag.

When "H", outputs VCOM="H", and when "L", outputs VCOM="L".

When EXTMODE="H", it can be "H" or "L".

M2: All clear flag.

Set it "H"

DUMMY DATA: Dummy data. It can be "H" or "L" ("L" is recommended.)

※M1: Frame inversion flag is enabled when EXTMODE="L".

※When SCS becomes "L", M0 and M2 are cleared.

## 6-5-5 COM Inversion

There are two types of inputs, COM signal serial input (EXTMODE="L") and external COM signal input (EXTMODE="H").

### EXTMODE="L"

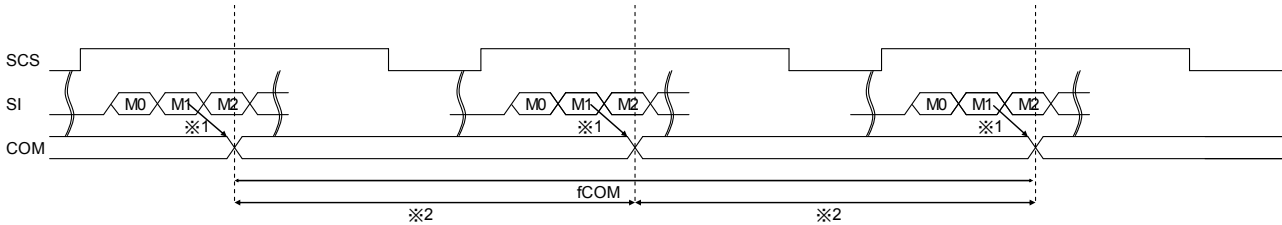

M1: LC polarity inversion flag: If M1 is "H" then VCOM="H" is output. If M1 is "L" then VCOM="L" is output.

※1: LC inversion has been changed by M1 flag statement.

※2: The periods of plus polarity and minus polarity should be same length as much as possible.

### EXTMODE="H" (COM inversion timing has two conditions )

#### ① EXTCOMIN input when the SCS signal is H.

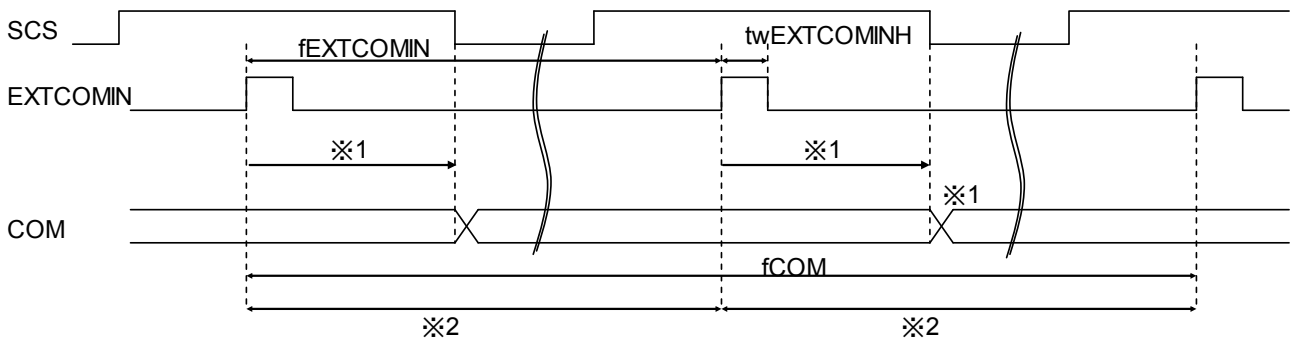

※1: LC inversion polarity has been set by the rising timing of EXTCOMIN in internal circuit block as COMZ signal.

※2: The period of EXTCOMIN should be constant.

#### ② EXTCOMIN input when the SCS signals is low.

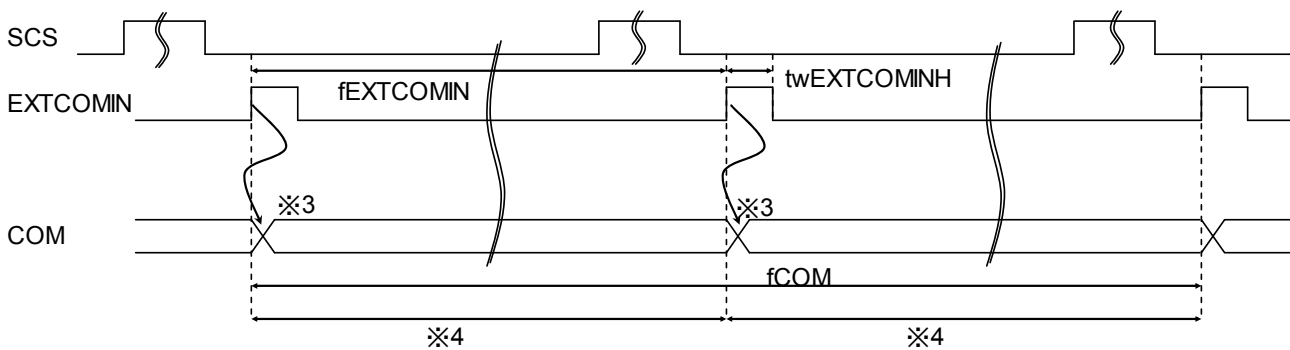

※3: LC inversion polarity has been set by the rising edge of EXTCOMIN.

※4: The period of EXTCOMIN should be constant.

## 6-6) Input Signal and Display, Gate address(Line) Setting

Data position in display[H,V]

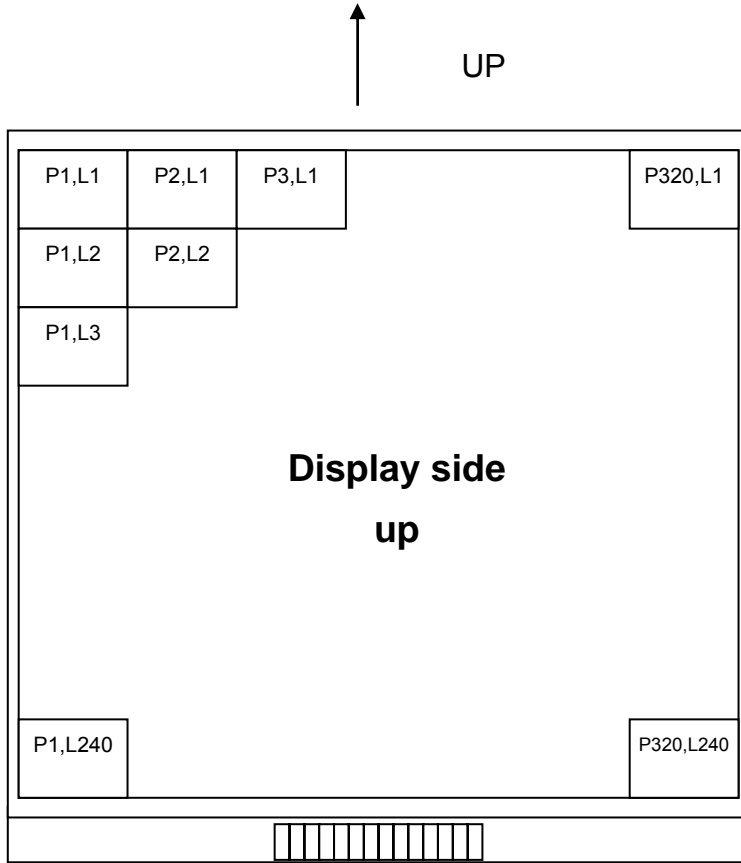

| Line | Gate Line Address Setup |     |     |     |     |     |     |     |
|------|-------------------------|-----|-----|-----|-----|-----|-----|-----|
|      | AG0                     | AG1 | AG2 | AG3 | AG4 | AG5 | AG6 | AG7 |
| L1   | H                       | L   | L   | L   | L   | L   | L   | L   |
| L2   | L                       | H   | L   | L   | L   | L   | L   | L   |
| L3   | H                       | H   | L   | L   | L   | L   | L   | L   |
| .    | .                       | .   | .   | .   | .   | .   | .   | .   |
| .    | .                       | .   | .   | .   | .   | .   | .   | .   |
| .    | .                       | .   | .   | .   | .   | .   | .   | .   |
| L238 | L                       | H   | H   | H   | L   | H   | H   | H   |
| L239 | H                       | H   | H   | H   | L   | H   | H   | H   |
| L240 | L                       | L   | L   | L   | H   | H   | H   | H   |

## 7. Optical characteristics

Table 7-1

Ta=25°C

| Item                  | Symbol | MIN.    | TYP.   | MAX. | unit      | Remark         |
|-----------------------|--------|---------|--------|------|-----------|----------------|
| Viewing angle<br>CR≥2 | H      | θ21,θ22 | (60)   |      | °(degree) | [Remark7-1]    |
|                       | V      | θ11     | (60)   |      | °(degree) |                |
|                       |        | θ12     | (60)   |      | °(degree) |                |
| Contrast ratio        | CR.    |         | (14)   |      |           | [Remark7-2, 3] |
| Reflectance           | R      |         | (17.5) |      | %         | [Remark7-3]    |
| Transmittance         | T      |         | 0.25   |      | %         | [Remark 7-5]   |
| Response time         | Rise   | τr      | 10     |      | ms        | [Remark 7-3,4] |
|                       | Fall   | τd      | 20     |      | ms        |                |
| Panel Chromaticity    | White  | x       | 0.307  |      |           | [Remark7-3]    |
|                       |        | y       | 0.330  |      |           |                |

[Remark7-1] Defintion of Viewint Angle

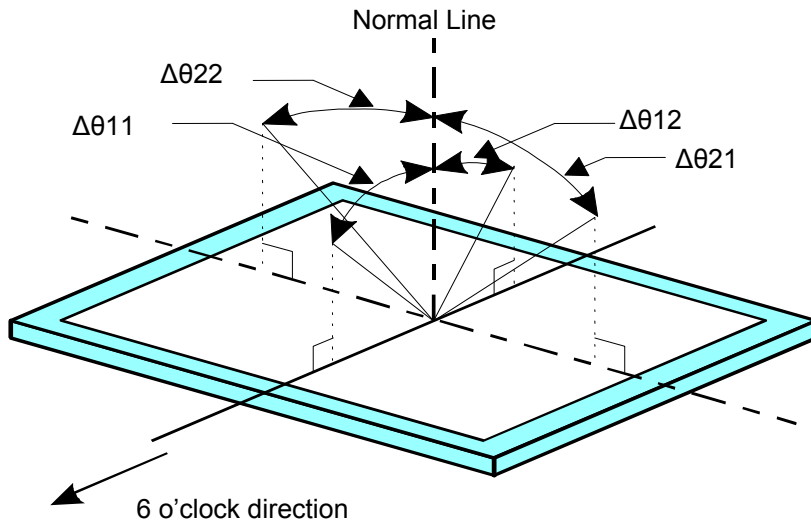

[Remark7-2] Defintion of Contrast Retio

$$\text{Contrast ratio(CR)} = \frac{\text{Reflection intensity in white display}}{\text{Reflection intensity in black display}}$$

|                                |                                 |                   |
|--------------------------------|---------------------------------|-------------------|
| SPEC No.<br><b>LCP2111038A</b> | MODEL No.<br><b>LS044Q7DH01</b> | PAGE<br><b>22</b> |
|--------------------------------|---------------------------------|-------------------|

[Remark7-3] Optical characteristics measurement equipment.

Figure 7-2 is for contrast ratio, reflectivity ratio, and panel chromaticity measurement, and figure 7-3 is for response time measurement. Both are to be conducted in a dark or room equipment to a dark room

Measurement equipment  
(CM-2002)

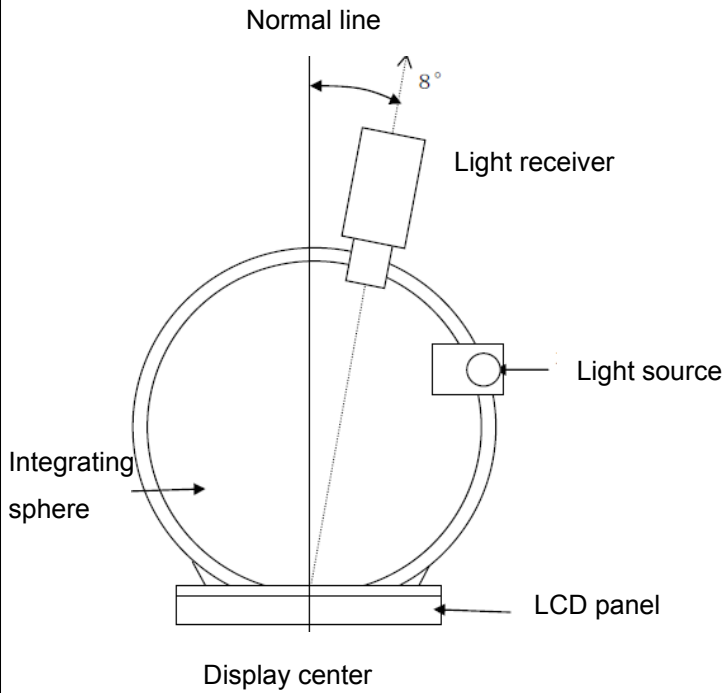

Fig7-2 Contrast ratio, Reflection ratio, Panel chromaticity of white

Measurement equipment  
(LCD-5200)

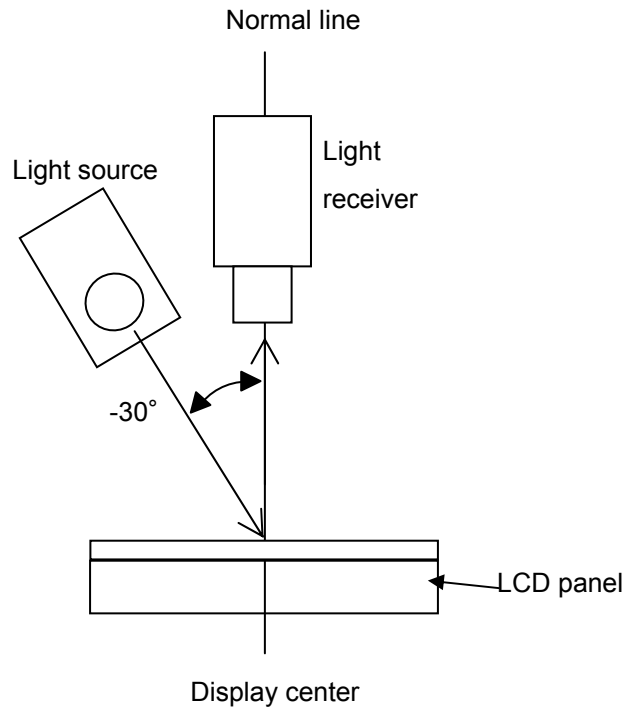
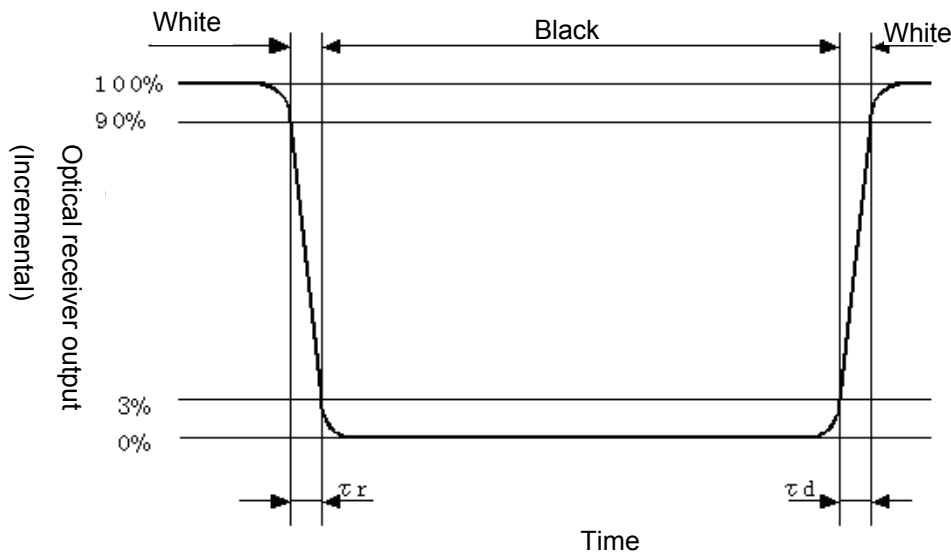

Fig7-3 response time

[Remark7-4] Respons time (Change in reflection ratio)

It's difined by the time change of optical receiver output when signal is input to display white or black



[Remark 7-5] Panel luminance calculation.

Backlight can be implemented underneath the panel, display can be shown with the luminance which is depended on the Backlight luminance. The luminance can be calculated by the panel transimisivty "(0.25%)" multiply "Backlight luminance".



|                                |                                 |                   |
|--------------------------------|---------------------------------|-------------------|
| SPEC No.<br><b>LCP2111038A</b> | MODEL No.<br><b>LS044Q7DH01</b> | PAGE<br><b>23</b> |
|--------------------------------|---------------------------------|-------------------|

## 8. Module outline

### 8-1) Outline dimension of the 4.4" (320x240) panel with FPC type

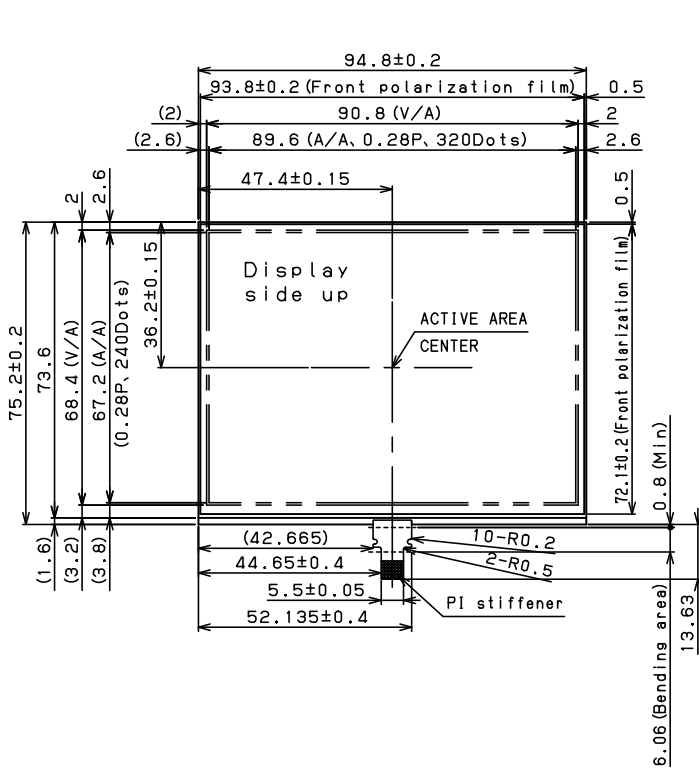

fig.8-1

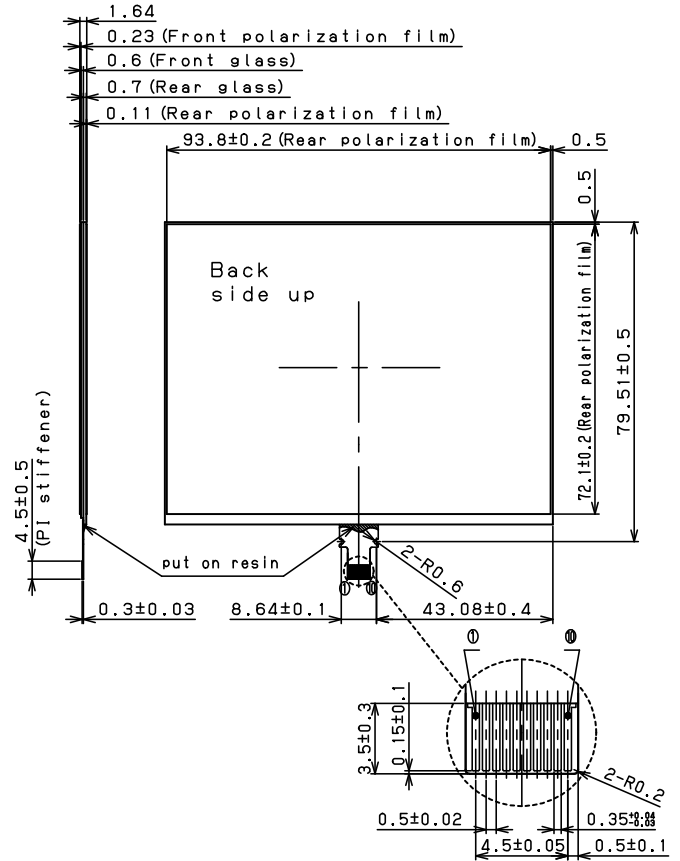

fig. 8-2

<Applicable connector> Lower contact type (SMK: CFP-4610-0150F/ Molex: 51441-1093H )

### 8-2) FPC Bend Specification

When bending FPC, bend where specified in Condition (1) and the bend R should be more than R specified in Condition (2). FPC is not to contact glass edge, and there should be no stress to connective area between panel and FPC.

Condition (1) FPC bend recommended area: more than 0.8mm from glass edge.

Condition (2) Minimum bend R: Inner diameter R0.45

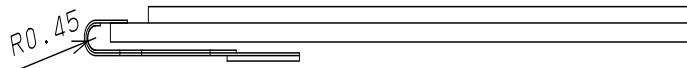

Fig.8-3

**[Remark 8-1]** Do not bend backward (toward front polarizer side)

**[Remark 8-2]** Do not hang LCD module by FPC or apply force to FPC.

**[Remark 8-3]** Bend frequency: 3 times or less (Repeat bend condition: 180° ~ 0° )

<Applicable connector> Upper contact type: (SMK : CFP-4510-0150F )

## 9. External capacitors

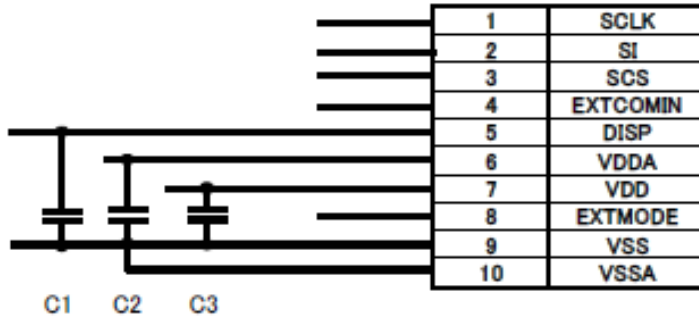

Fig. 9-1 External capacitor recommendation capacity value

<Recommended capacity value>

C1: DISP- VSS: rank B 0.1uF Ceramic capacitor (The capacitor is for ESD and removable.)

C2: VDDA- VSS: rank B 1uF Ceramic capacitor

C3: VDD- VSS: rank B 1uF Ceramic capacitor

※Above circuit and parts are only recommendation.

For actual use, please evaluate their conformity with your system and design.

(Capacitor pressure resistance can be larger than resistance indicated above.)

## 10. External Power Supply Circuit

An external power supply circuit is necessary to drive the Pixel Memory LCD with the 3V battery.

Table 10-1 shows power supply IC of the recommendation.

Table 10-1

| Maker                  | Model Number | Note             |
|------------------------|--------------|------------------|
| SII                    | S-8821       | Charge pump type |
| National Semiconductor | LM2750       | Charge pump type |

Refer to specifications of each power supply IC for a detailed specification.

Set the constant value after it evaluating it sufficiently by an actual application when you use it.

## Electrical specification

Table 10-2

| Model Number | Vin [V] |     | Vout |     |     | Iout [A] |
|--------------|---------|-----|------|-----|-----|----------|
|              | min     | max | min  | typ | max |          |
| S-8821       | 2.8     | 5.0 | 4.9  | 5.0 | 5.1 | 0.04     |
| LM2750       | 2.7     | 5.6 | 4.8  | 5.0 | 5.2 | 0.04     |

Refer to specifications of each power supply IC for a detailed specification.

Set the constant value after it evaluating it sufficiently by an actual application when you use it.

## Reference circuit

The reference circuit is shown below.

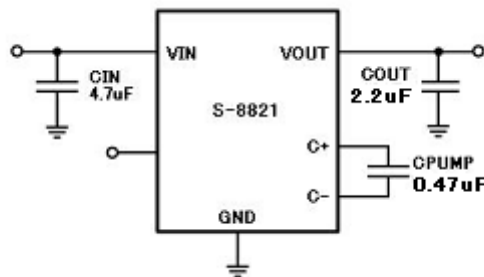

S-8821

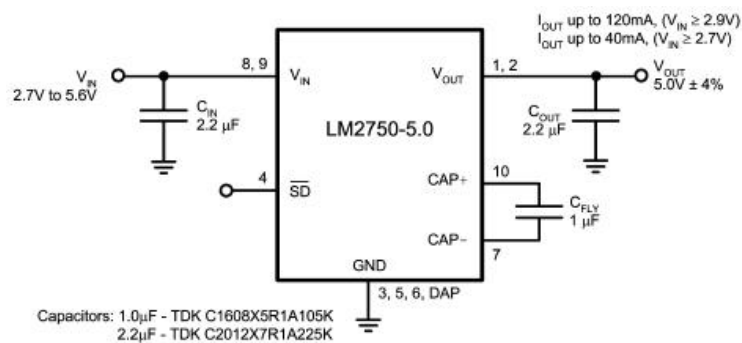

Capacitors: 1.0µF - TDK C1608X5R1A105K  
2.2µF - TDK C2012X7R1A225K

LM2750

## 11. Packaging

11-1) Serial number (Ink-jet print) will be indicated on serial number label as indicated in Figure 11-1 outline dimension figure.

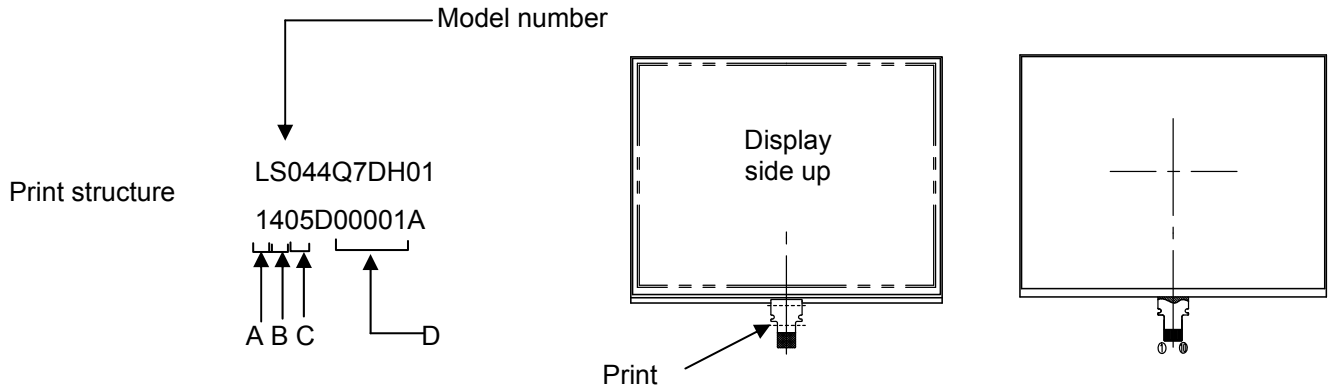

Serial number specifications

A: a single figure of the year

B: month(1,2....9,X,Y,Z)

C: day

D: serial number

Fig. 11-1 Serial number print position

## 11-2) Forwarding form

1) Piling number of cartons : Max TBD

Package quality in a carton : TBD pcs

2) Storage condition

- Temperature: 0~40°C
- Humidity: 60%RH or lower (at 40°C)

There should be no condensation at low temperature and high humidity.

- Atmosphere: No harmful gas, such as acid or alkali, which causes severe corrosion on electronic parts and wiring, are to be detected.
- Period: About 3 months
- Opening the package: in order to prevent electrostatic damage to TFT modules, room humidity should be made over 50%RH and take effective measure such as use of earth when opening the package.

## 11-3) Packaging

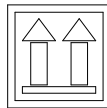
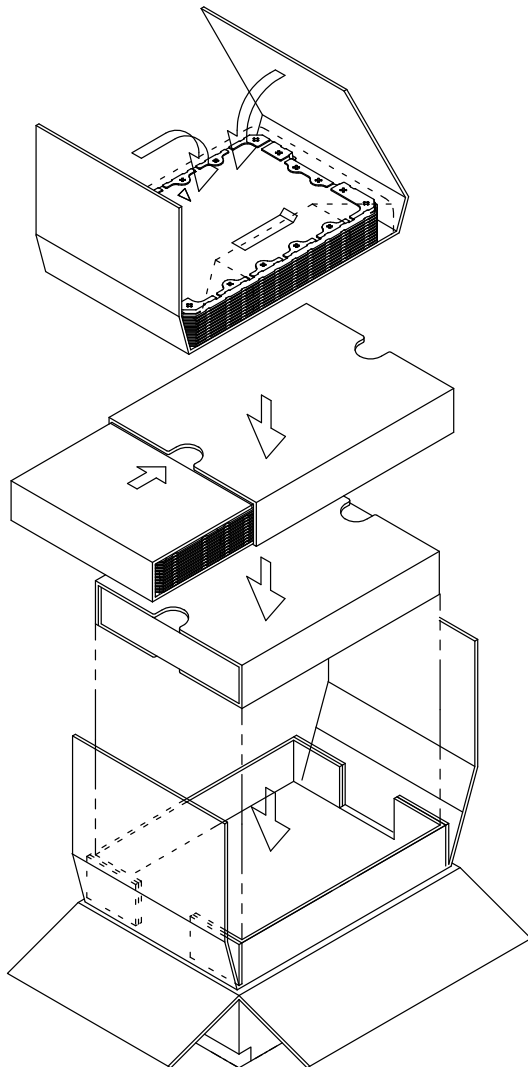

FRAGILE  
取扱注意



**SHARP®**  
Electronic Components

|            |  |                            |
|------------|--|----------------------------|
| TYPE       |  | 社内品番: (4S) LS044*****      |
| QUANTITY   |  | LotNO. : (1T) 2009. xx. xx |
| LOT (DATE) |  | Quantity: (Q) **** PCS     |
|            |  | ユーザー品番 :                   |
|            |  | シャープ物流用ラベルです。 ( ) ( )      |

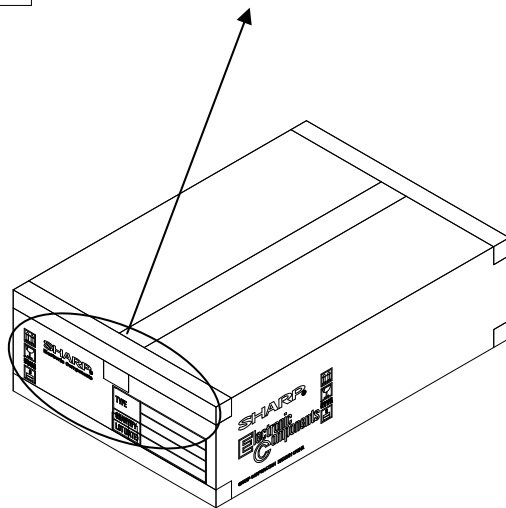

Fig. 11-2 Packaging Form