

## TOUCH CONTROL LAMP DIMMER

December 2000

### FEATURES:

- Phase-lock loop synchronization allows use in Wall Switch applications.
- Provides brightness control of incandescent lamps with touch plates or mechanical switches.
- Controls the "duty cycle" from 23% to 88% (conduction angles for AC half-cycles between 41° and 158°, respectively.)
- Operates at 50Hz/60Hz line frequency.
- Extension input for remote activation.
- Input for slow dimming.
- +12V to +18V DC Power Supply voltage. (V<sub>SS</sub> - V<sub>DD</sub>)
- LS7231 to LS7234 (DIP) - See Figure 1  
LS7231-S to LS7234-S (SOIC)

### DESCRIPTION:

LS7231 through LS7234 are a series of monolithic, MOS integrated circuits designed for the control of brightness of incandescent lamps. The outputs of these ICs control the brightness of a lamp by controlling the firing angle of a triac connected in series with the lamp. All internal timings are synchronized with the line frequency by means of a built-in phase-lock loop circuit. The output occurs once every half-cycle of the line frequency. Within the half-cycle, the output can be positioned anywhere between 158° conduction angle for maximum brightness and 41° conduction angle for minimum brightness in relation to the AC line frequency. The positioning of the output is controlled by applying a low level at the SENS input or a high level at the EXT input.

These functions may be implemented with very few interface components, as shown in Figure 5. When implemented in this manner, touching of the Touch Plate causes the lamp brightness to change as follows:

1. If the Touch Plate is touched momentarily (42ms to 333ms), the lamp is:
  - a) turned off if it was on,
  - b) turned on if it was off.
 The brightness resulting is either full brightness or depending on the circuit type, a previous brightness stored in the IC memory.
2. If the Touch Plate is touched for a prolonged time (more than 342ms) the light intensity changes slowly. As long as the touch is maintained, the change continues; the direction of change reverses whenever the maximum or minimum brightness is reached.

### PIN ASSIGNMENT - TOP VIEW

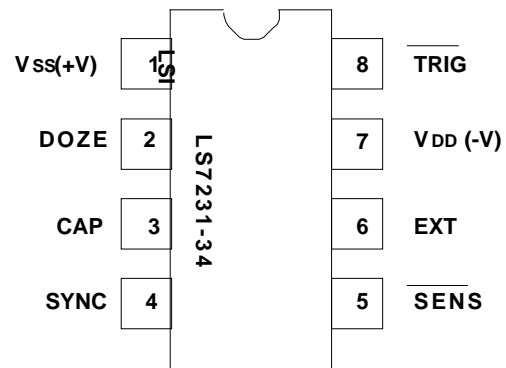

FIGURE 1

The IC also provides an input for slow dimming. By applying a slow clock to this input, the lamp can be dimmed slowly until total turn off occurs. This feature can be useful at bedtime in a child's room.

### INPUT/OUTPUT DESCRIPTION:

#### V<sub>SS</sub> (Pin 1)

Supply voltage positive terminal.

#### DOZE (Pin 2)

A clock applied to this input causes the brightness to decrease in equal increments with each negative transition of the clock. Eventually, when the lamp turns off, this input has no further effect. The lamp can be turned on again by activating either the SENS input or the EXT input. For the transition from maximum brightness to off, a total of 83 clock pulses are needed at the DOZE input. When either the SENS or the EXT input is active, the DOZE input is disabled. (See Figure 7)

#### CAP (Pin 3)

The CAP input is for the PLL filter capacitor. A 0.047μF capacitor should be connected to this input.

The functional differences of different versions of the light dimmer ICs are explained in Table 1 and the TRIG output conduction angle diagrams in Figure 2.

**TABLE 1**  
**TOUCH TYPE**

PART NUMBER	TOUCH TYPE				DIMMING DIRECTION REVERSAL (Note 3)
	SHORT (Ts1 Duration)		LONG (Ts2 Duration)		
	PRE-TOUCH $\emptyset$	POST-TOUCH $\emptyset$	PRE-TOUCH $\emptyset$	POST-TOUCH $\emptyset$	
LS7231	Off Max Intermediate	Max Off Off	Off Max Intermediate	Starts varying at Min Starts varying at Max Starts varying at Pre-Touch brightness	N/A N/A NO
LS7232	Off  Max Intermediate	Memory (Note 1) Off Off	Off  Max Intermediate	Starts varying at Memory (Note 2) Starts varying at Max Starts varying at Pre-Touch brightness	YES  N/A YES
LS7233	Off Max Intermediate	Max Off Off	Off Max Intermediate	Starts varying at Min Starts varying at Max Starts varying at Pre-Touch brightness	N/A N/A YES
LS7234	Off  Max Intermediate	Memory (Note 1) Off Off	Off  Max Intermediate	Starts varying at Memory (Note 2) Starts varying at Max Starts varying at Pre-Touch brightness	NO  N/A NO

**NOTE 1:** "Memory" refers to the conduction angle,  $\emptyset$  which existed prior to the current off-state. First time after power-up, the Memory value defaults to maximum conduction angle.

**NOTE 2:** First time after power-up, LONG touch causes intensity to vary starting at minimum conduction angle.

**NOTE 3:** NO = Dimming direction does not reverse from prior dimming direction.  
YES = Dimming direction does reverse from prior dimming direction.  
N/A = Does not apply

#### SYNC (Pin 4)

The AC Line Frequency is applied to this input through an external RC circuit (See Figure 5). The Phase-Lock Loop in the IC synchronizes all internal timings to the AC signal at the SYNC input.

#### SENS (Pin 5)

A low level activates this input (See Table 1) which controls the turn-on, turn-off and conduction angle  $\emptyset$  (See Figure 3) of the TRIG signal with respect to the SYNC input.

#### EXT (Pin 6)

The EXT input is functionally identical to the SENS input except that a high level activates this input. It is recommended that the EXT input be used instead of the SENS input when long extension wires are employed between the IC and the Sensing Circuitry (See Figure 5 and Figure 6) because the EXT input is less susceptible to "Noise".

#### VDD (Pin 4)

Supply voltage negative terminal.

#### TRIG (Pin 8)

The TRIG output is a low level pulse occurring once every half-cycle of the SYNC input. The conduction angle,  $\emptyset$ , of the output in relation to the SYNC signal controls the lamp brightness.

In continuous dimming operation (i.e. when the SENS input is continuously held low) the TRIG conduction angle,  $\emptyset$ , sweeps up and down between 41° and 158° continuously. The time vs  $\emptyset$  curve is not linear (See Figure 2). Between two maxima on this curve, there are 4 discontinuous points labeled A1, B1, B2, A2. The discontinuities are as follows:

1. From maximum to A1. In this region,  $\emptyset$  is changed by equal increments ( $\emptyset$ ) for every 2 SYNC clocks.
2. From A1 to B1. In this region, the increments ( $\emptyset$ ) take place for every 4 SYNC clocks.
3. From B1 to B2. In this region  $\emptyset$  is held at a constant level ( $\emptyset = 0$ ).
4. From B2 to A2. Same as 2.
5. From A2 to Max. Same as 1.

The slower rate of change in  $\emptyset$  over A1B1B2A2 region is to accommodate for eye adjustment at lower light intensity.

**ABSOLUTE MAXIMUM RATINGS:**

PARAMETER	SYMBOL	VALUE	UNIT
DC Supply Voltage	V <sub>SS</sub>	+20	V
Any Input Voltage	V <sub>IN</sub>	V <sub>SS</sub> -20 to V <sub>SS</sub> + 0.5	V
Operating Temperature	T <sub>A</sub>	0 to +80	°C
Storage Temperature	T <sub>STG</sub>	-65 to +150	°C

**DC ELECTRICAL CHARACTERISTICS:**(T<sub>A</sub> = 25°C, all voltages referenced to V<sub>DD</sub>)

PARAMETER	SYMBOL	MIN	TYP	MAX	UNIT	CONDITION
Supply Voltage	V <sub>SS</sub>	+12	-	+18	V	-
Supply Current	I <sub>SS</sub>	-	1.0	1.4	mA	V <sub>SS</sub> = +15V, output off
<b>Input Voltages:</b>						
<b>DOZE</b> LO	V <sub>I</sub> ZL	0	-	V <sub>SS</sub> -6	V	-
<b>DOZE</b> HI	V <sub>I</sub> ZH	V <sub>SS</sub> -2	-	V <sub>SS</sub>	V	-
<b>SYNC</b> LO	V <sub>I</sub> RL	0	-	V <sub>SS</sub> -9.5	V	-
<b>SYNC</b> HI	V <sub>I</sub> RH	V <sub>SS</sub> -5.5	-	V <sub>SS</sub>	V	-
<b>SENS</b> LO	V <sub>I</sub> OL	0	-	V <sub>SS</sub> -8	V	-
<b>SENS</b> HI	V <sub>I</sub> OH	V <sub>SS</sub> -2	-	V <sub>SS</sub>	V	-
<b>EXT</b> LO	V <sub>I</sub> VL	0	-	V <sub>SS</sub> -8	V	-
<b>EXT</b> HI	V <sub>I</sub> VH	V <sub>SS</sub> -2	-	V <sub>SS</sub>	V	-
<b>Input Current:</b>						
<b>SYNC, SENS, EXT</b> HI	I <sub>I</sub> H	-	-	110	μA	With Series 1.5M Resistor to 115VAC Line
<b>SYNC, SENS, EXT</b> LO	I <sub>I</sub> L	-	-	100	nA	-
<b>DOZE</b> HI	I <sub>I</sub> H	-	-	100	nA	-
<b>DOZE</b> LO	I <sub>I</sub> L	-	-	100	nA	-
<b>TRIG</b> HI Voltage	V <sub>O</sub> H	-	V <sub>SS</sub>	-	V	-
<b>TRIG</b> LO Voltage	V <sub>O</sub> L	-	V <sub>SS</sub> -8	-	V	V <sub>SS</sub> = +15V
<b>TRIG</b> Sink Current	I <sub>O</sub> S	25	-	-	mA	V <sub>SS</sub> = +15V V <sub>O</sub> L = V <sub>SS</sub> -4V

**TIMING CHARACTERISTICS** (See Figures 2 and 3):All timings are based on f<sub>s</sub> = 60Hz, unless otherwise specified. 50Hz timings are 1.2 times 60Hz timings.

PARAMETER	SYMBOL	MIN	TYP	MAX	UNIT
<b>SYNC</b> Frequency	f <sub>s</sub>	40	-	70	Hz
<b>SHORT TOUCH</b> (ON/OFF Operation)	T <sub>S</sub> 1	42	-	333	ms
<b>LONG TOUCH</b> (Dimming Operation)	T <sub>S</sub> 2	342	-	infinite	ms
<b>DOZE</b> Frequency	-	-	-	500	Hz
<b>TRIG</b> Pulse Width	T <sub>w</sub>	-	33	-	μs
<b>TRIG</b> Conduction-Angle (Note 1)	∅	41	-	158	degrees
∅ Period (Max to Max in continuous dimming)	-	-	7.64	-	seconds
<b>A1B1 = B2A2</b> duration	-	-	934	-	ms
<b>B1B2</b> Min. intensity dwell	-	-	500	-	ms

**NOTE 1.**

In the circuit schematic shown in Figure 5, the SYNC input signal is delayed in phase with respect to the AC Line by about 7°. This delay reduces the conduction angle, ∅ with respect to the AC Line by 7° from the values shown above.

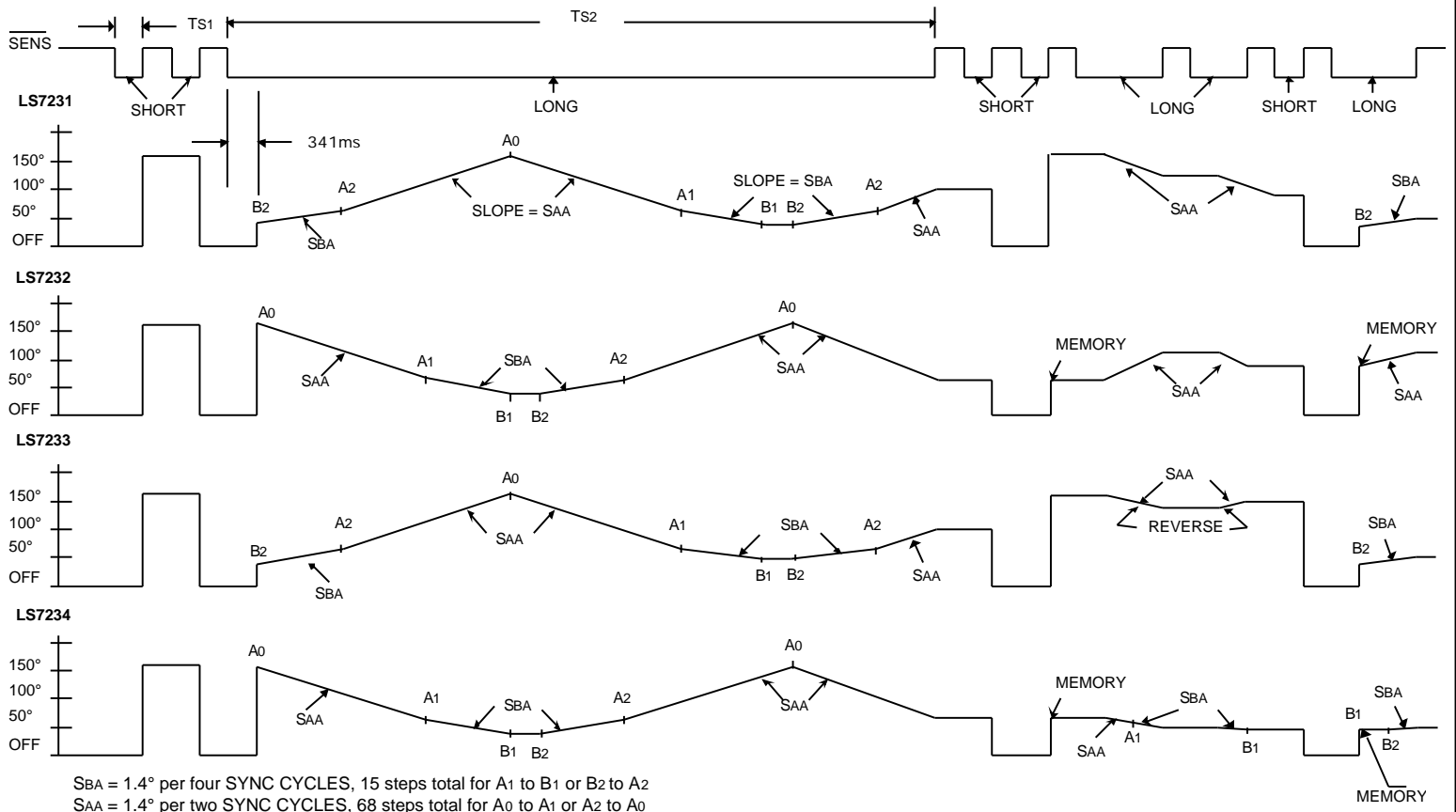

**FIGURE 2. TRIG OUTPUT CONDUCTION ANGLE,  $\phi$ , VS SENS INPUT**

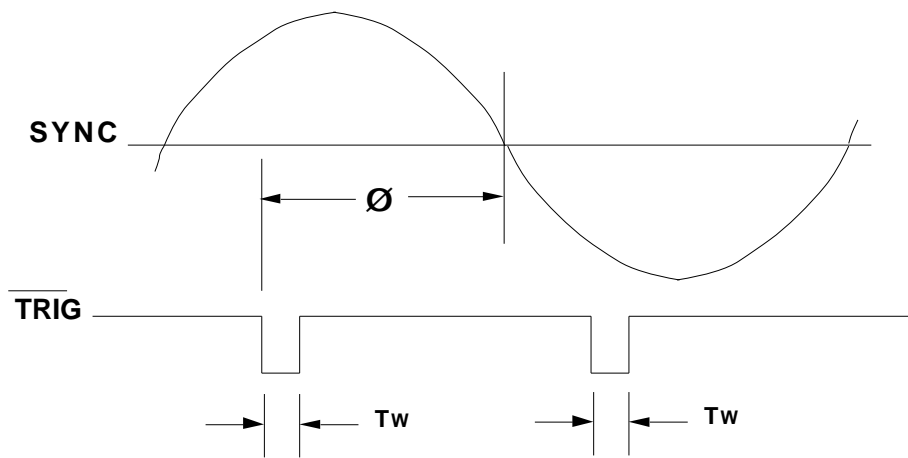

FIGURE 3. TRIG OUTPUT CONDUCTION ANGLE, Ø

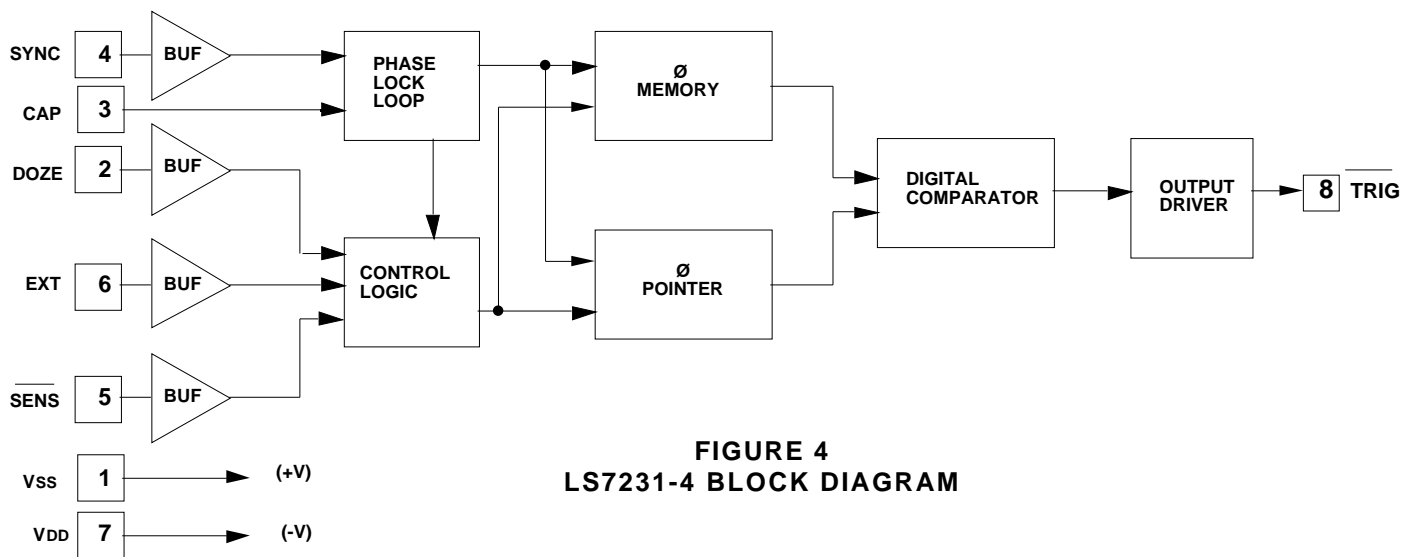

FIGURE 4  
LS7231-4 BLOCK DIAGRAM

#### APPLICATION EXAMPLE:

A typical implementation of a lamp dimmer circuit is shown in Fig. 5. Here the brightness of the lamp is set by touching the Touch Plate. The functions of different components are as follows:

- The 15V DC supply for the chip is provided by Z, D1, R1, C2 and C5.
- R2 and C4 generate the filtered signal for the SYNC input for synchronizing the internal PLL with the line frequency.
- R3 and C7 act as a filter circuit for the electronic extension. If extensions are not used, the EXT input (Pin 6) should be tied to VDD (Pin 7).
- R4, R5, R6 set up the sensitivity of the SENS input. C6 provides noise filtering.
- C3 is the filter capacitor for the internal PLL.
- R8 provides current limiting and isolation between the chip output and the triac gate.
- C1 and L are RF filter circuits.

In the case of momentary power failure, the circuit state remains unchanged for a period of up to 1 sec. For longer power interruptions, the output is shut off.

**FIGURE 5. A Typical Lamp Dimmer**

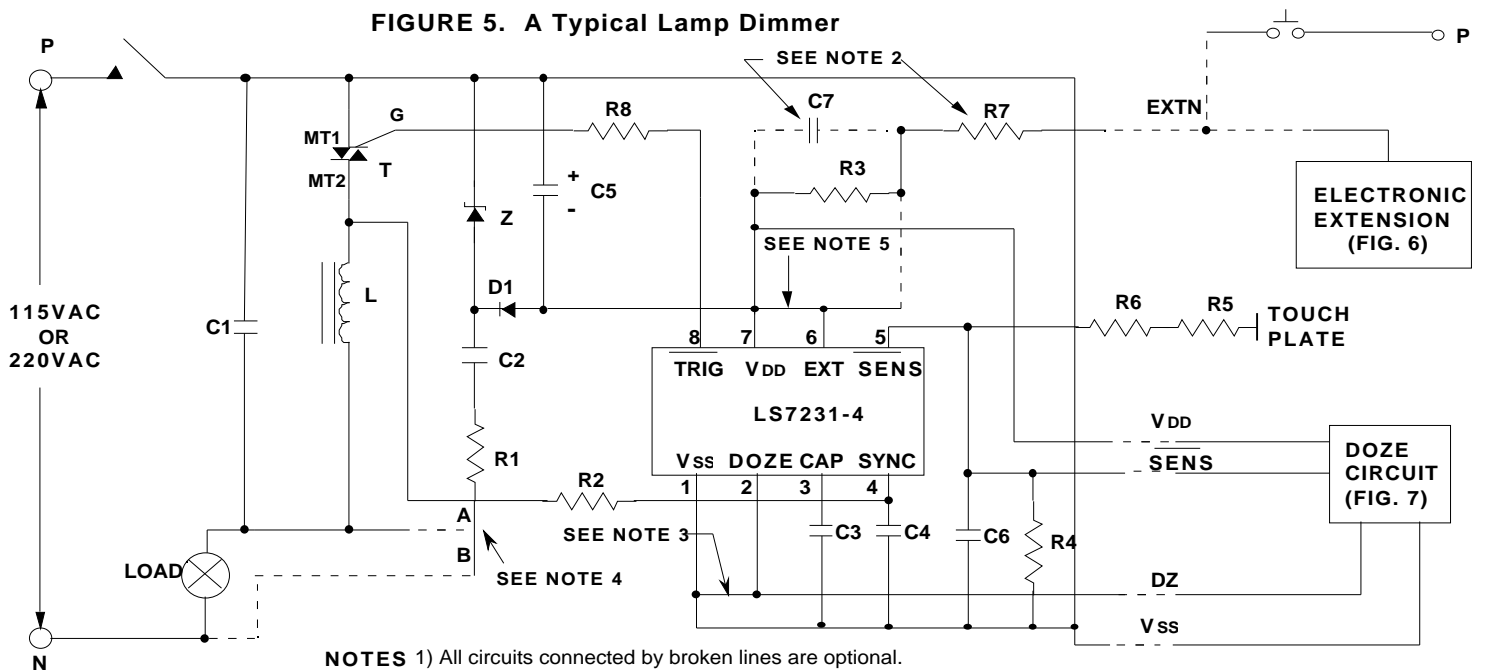

- NOTES**
- 1) All circuits connected by broken lines are optional.
  - 2) C7 is used only with electronic extension and R7 is used only with mechanical switch.
  - 3) Connection between Pin 1 & Pin 2 should be broken when DOZE circuit is used.
  - 4) Use Connection A when Neutral is not available. Use Connection B when Neutral is available.
  - 5) Connection between Pin 6 & Pin 7 should be broken when EXT is used.

**115V**

- C1 = 0.15 $\mu$ F, 200V  
**(1)** C2 = 0.33 $\mu$ F, 200V  
 C3 = 0.047 $\mu$ F, 25V  
 C4 = 470pF, 25V  
 C5 = 47 $\mu$ F, 25V  
 C6 = 680pF, 25V  
 C7 = 0.1 $\mu$ F, 25V  
**(2)** R1 = 270  $\Omega$ , 1W  
 R2 = 1.5M  $\Omega$ , 1/4W  
 R3 = 1.5M  $\Omega$ , 1/4W  
 R4 = 1M  $\Omega$  to 5M  $\Omega$ , 1/4W  
 (Select for sensitivity)  
 R5, R6 = 2.7M  $\Omega$ , 1/4W  
 R7 = 150K  $\Omega$ , 1/4W  
 R8 = 100  $\Omega$ , 1/4W  
 D1 = 1N4148  
 Z = 15V, 1W (Zener)  
 T = Q4006L4 Triac (Typical)  
 L = 100 $\mu$ H (RFI Filter)

- (1)** For Connection A. Use 0.22 $\mu$ F for Connection B.  
**(2)** For Connection A. Use 1/4W for Connection B.

**220V**

- C1 = 0.15 $\mu$ F, 400V  
**(3)** C2 = 0.22 $\mu$ F, 400V  
 C3 = 0.047 $\mu$ F, 25V  
 C4 = 470pF, 25V  
 C5 = 47 $\mu$ F, 25V  
 C6 = 680pF, 25V  
 C7 = 0.1 $\mu$ F, 25V  
**(4)** R1 = 1K  $\Omega$ , 2W  
 R2 = 1.5M  $\Omega$ , 1/4W  
 R3 = 1.5M  $\Omega$ , 1/4W  
 R4 = 1M  $\Omega$  to 5M  $\Omega$ , 1/4W  
 (Select for sensitivity)  
 R5, R6 = 4.7M  $\Omega$ , 1/4W  
 R7 = 150K  $\Omega$ , 1/4W  
 R8 = 100  $\Omega$ , 1/4W  
 D1 = 1N4148  
 Z = 15V, 1W (Zener)  
 T = Q5004L4 Triac (Typical)  
 L = 200 $\mu$ H (RFI Filter)

- (3)** For Connection A. Use 0.1 $\mu$ F for Connection B.  
**(4)** For Connection A. Use 1/4W for Connection B.

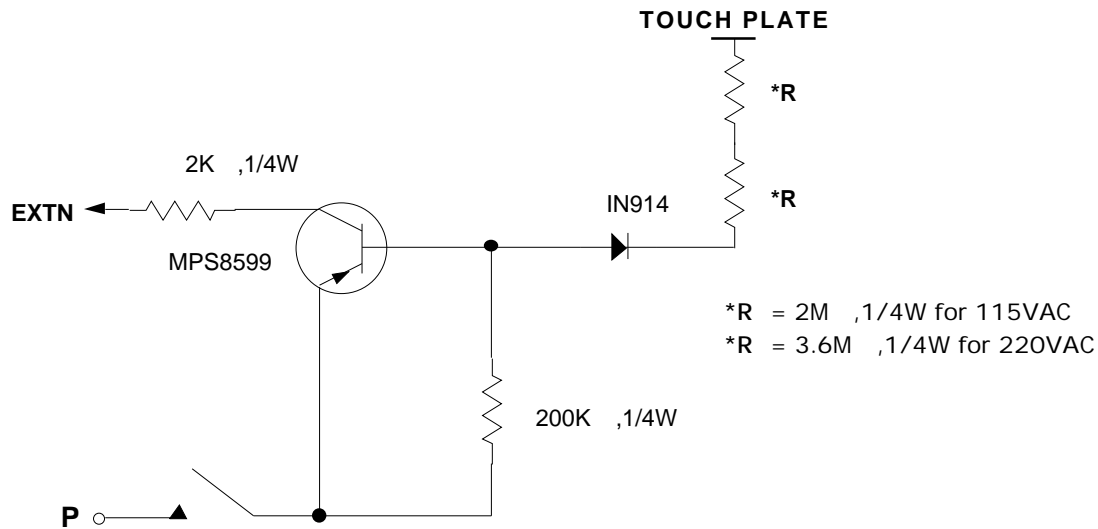

FIGURE 6. ELECTRONIC EXTENSION

**EXTENSIONS:**

All switching and dimming functions can also be implemented by utilizing the EXT input. This can be done by either a mechanical switch or the electronic switch in conjunction with a Touch Plate as shown in Figure 6. When the plate is touched, a logic high level is generated at the EXT input of the IC for both half-cycles of the line frequency. (See Figure 5)

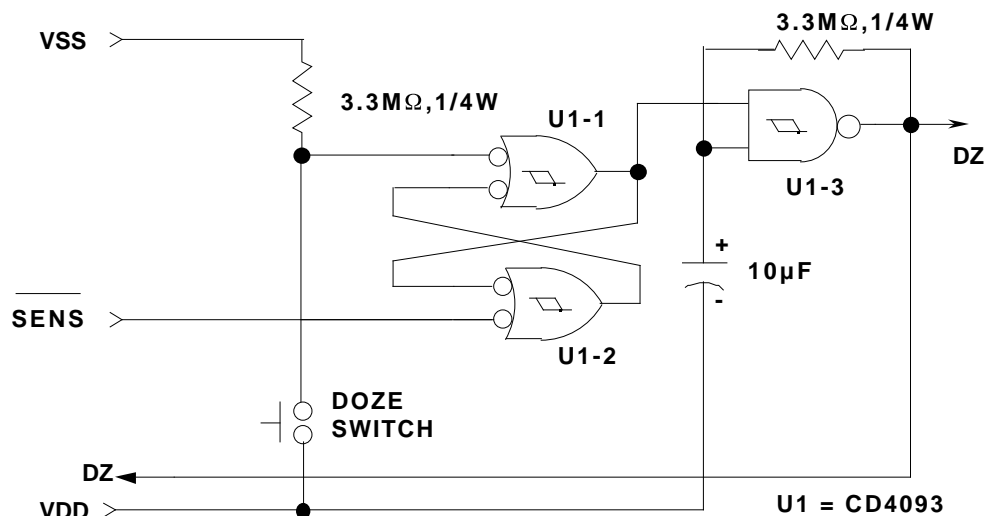

FIGURE 7. DOZE CIRCUIT

**DOZE CIRCUIT:**

The DOZE circuit shown in Figure 7 generates a slow clock (0.04Hz) at the DZ terminal. If the Touch Plate (Figure 5) is not touched, the SENS terminal of the DOZE circuit of Figure 7 sits at a logic high level. A momentary pressing of the DOZE switch sets the SR flip-flop, enabling the oscillator. Every negative transition of the clock (DZ terminal) causes the light intensity to be reduced by equal increments, until eventually the light is shut off. The oscillator has no further effect on the dimmer circuit. When the light is turned on again by touching the Touch Plate, the SR flip-flop is reset and the DZ clock is turned off.

When the DOZE circuit is used, the connection between DOZE input (Pin 2) and Vss (Pin 1) as shown in Figure 5, should be removed.

**FIGURE 8. A SWITCH-OPERATED LAMP DIMMER**

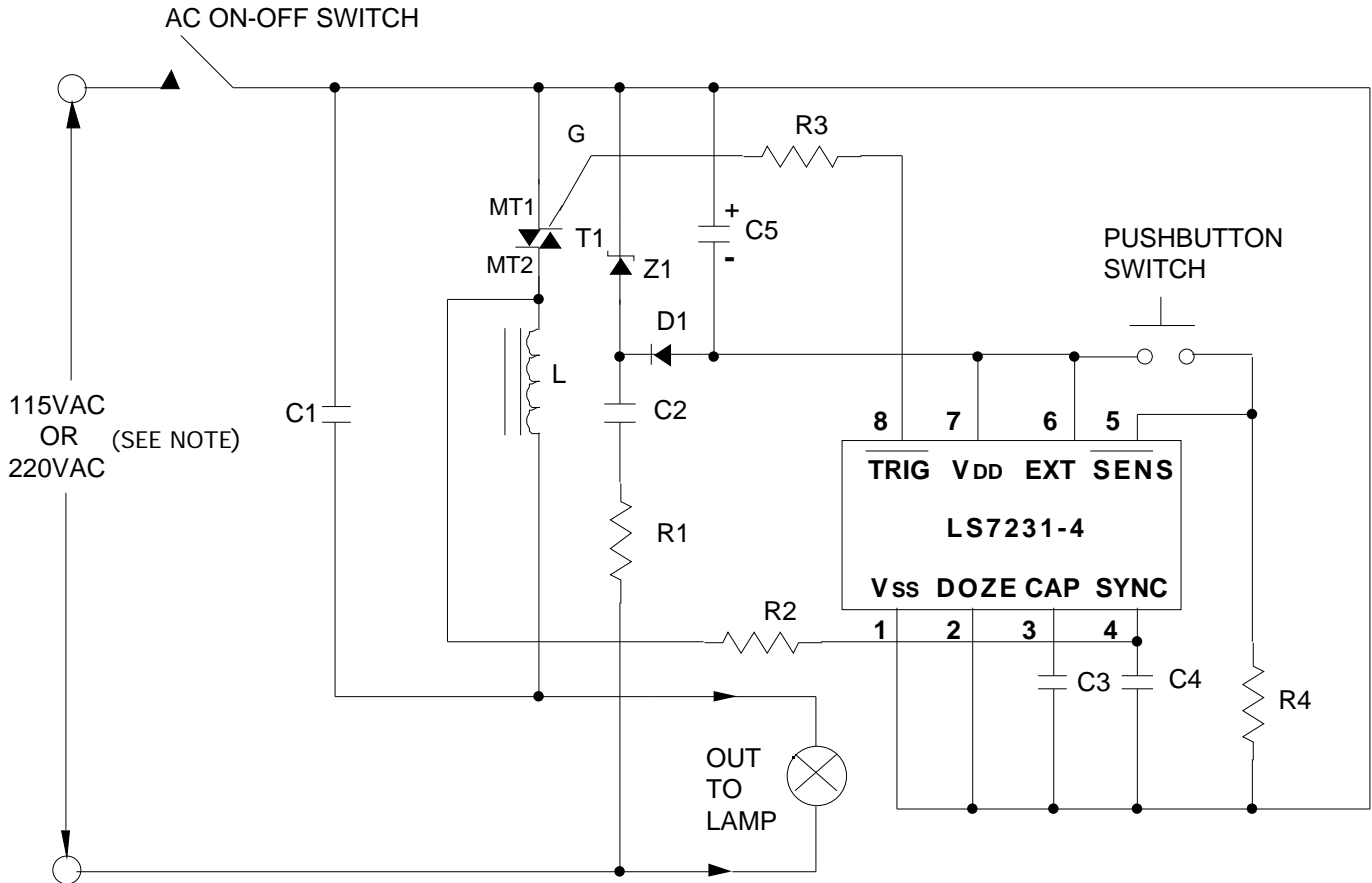

**NOTE:** Operation is independent of Line Plug Polarity

**115V**

- C1 = 0.15 $\mu$ F, 200V
- C2 = 0.22 $\mu$ F, 200V
- C3 = 0.047 $\mu$ F, 25V
- C4 = 470pF, 25V
- C5 = 47 $\mu$ F, 25V
- R1 = 270  $\Omega$ , 1/4W
- R2 = 1.5M  $\Omega$ , 1/4W
- R3 = 100  $\Omega$ , 1/4W
- R4 = 1M  $\Omega$ , 1/4W
- D1 = IN4148
- Z1 = 15V, 1W (Zener)
- T1 = Q4008L4 (Typical)
- L = 100 $\mu$ H (RFI Filter)

**220V**

- C1 = 0.15 $\mu$ F, 400V
- C2 = 0.1 $\mu$ F, 400V
- C3 = 0.047 $\mu$ F, 25V
- C4 = 470pF, 25V
- C5 = 47 $\mu$ F, 25V
- R1 = 1K  $\Omega$ , 1/4W
- R2 = 1.5M  $\Omega$ , 1/4W
- R3 = 100  $\Omega$ , 1/4W
- R4 = 1M  $\Omega$ , 1/4W
- D1 = IN4148
- Z1 = 15V, 1W (Zener)
- T1 = Q5004L4 (Typical)
- L = 200 $\mu$ H (RFI Filter)

**APPLICATIONS:**

1. Foot-Switch Dimmer for large floor lamps.
2. Hand-Switch Dimmer for end-table lamps.

The information included herein is believed to be accurate and reliable. However, LSI Computer Systems, Inc. assumes no responsibilities for inaccuracies, nor for any infringements of patent rights of others which may result from its use.