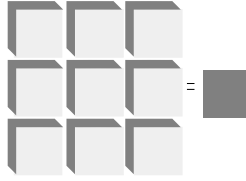

LSI/CSI**LS7366**

LSI Computer Systems, Inc. 1235 Walt Whitman Road, Melville, NY 11747 (631) 271-0400 FAX (631) 271-0405

32-BIT QUADRATURE COUNTER WITH SERIAL INTERFACE

January 2005

GENERAL FEATURES:

- Operating voltage: 3.0V to 5.5V (V_{DD} - V_{SS})
- 5V count frequency: 40MHz
- 3V count frequency: 20MHz
- 32-bit counter (CNTR).
- 32-bit data register (DTR) and comparator.
- 32-bit output register (OTR).
- Two 8-bit mode registers (MDR0, MDR1) for programmable functional modes.
- 8-bit instruction register (IR).
- 8-bit status register (STR).
- Latched Interrupt output on Carry or Borrow or Compare or Index.
- Index driven counter load, output register load or counter reset.
- Internal quadrature clock decoder and filter.
- x1, x2 or x4 mode of quadrature counting.
- Non-quadrature up/down counting.
- Modulo-N, Non-recycle, Range-limit or Free-running modes of counting
- 8-bit, 16-bit, 24-bit and 32-bit programmable configuration synchronous (SPI) serial interface
- LS7366 (DIP); LS7366-S (SOIC); LS7366-TS (TSSOP)
- See Figure 1-

SPI/MICROWIRE (Serial Peripheral Interface):

- Standard 4-wire connection: MOSI, MISO, SS/ and SCK.
- Slave mode only.

GENERAL DESCRIPTION:

LS7366 is a 32-bit CMOS counter, with direct interface for quadrature clocks from incremental encoders. It also interfaces with the index signals from incremental encoders to perform variety of marker functions.

For communications with microprocessors or microcontrollers, it provides a 4-wire SPI/MICROWIRE bus. The four standard bus I/Os are SS/, SCK, MISO and MOSI. The data transfer between a microcontroller and a slave LS7366 is synchronous. The synchronization is done by the SCK clocks supplied by the microcontroller. Each transmission is organized in blocks of 1 to 5 bytes of data. A transmission cycle is initiated by a high to low transition of the SS/ input. The first byte received in a transmission cycle is always an instruction byte, whereas the second through the fifth bytes are always interpreted as data bytes. A transmission cycle is terminated with the low to high transition of the SS/ input. Received bytes are shifted in at the MOSI input, MSB first, with the leading edges (high transition) of the SCK clocks. Output data are shifted out on the MISO output, MSB first, with the trailing edges (low transition) of the SCK clocks.

PIN ASSIGNMENT
TOP VIEW

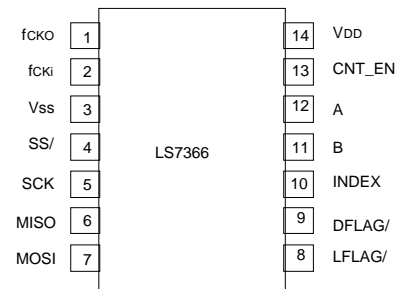

FIGURE 1

Read and write commands cannot be combined. For example, when the device is shifting out read data on MISO output, it ignores the MOSI input, even though the SS/ input is active. SS/ must be terminated and reasserted before the device will accept a new command.

The counter can be configured to operate as a 1, 2, 3 or 4-byte counter. When configured as a n-byte counter, the CNTR, DTR and OTR are all configured as n-byte registers, where n = 1, 2, 3 or 4. The content of the instruction/data identity is automatically adjusted to match the n-byte configuration. For example, if the counter is configured as a 2-byte counter, the instruction "write to DTR" expects 2 data bytes following the instruction byte. If the counter is configured as a 3-byte counter, the same instruction will expect 3 bytes of data following the instruction byte.

Following the transfer of the appropriate number of bytes any further attempt of data transfer is ignored until a new instruction cycle is started by switching the SS/ input to high and then low.

The counter can be programmed to operate in a number of different modes, with the operating characteristics being written into the two mode registers MDR0 and MDR1. Hardware I/Os are provided for event driven operations, such as processor interrupt and index related functions.

I/O Pins:

Following is a description of all the input/output pins.

A (Pin 12) B (Pin 11)

Inputs. A and B quadrature clock outputs from incremental encoders are directly applied to the A and B inputs of the LS7366. These clocks are ideally 90 degrees out-of-phase signals. A and B inputs are validated by on-chip digital filters and then decoded for up/down direction and count clocks. In non-quadrature mode, A serves as the count input and B serves as the direction input (B = high enables up count, B = low enables down count). In non-quadrature mode, the A and B inputs are not filtered internally, and are instantaneous in nature.

INDEX (Pin 10)

Input. The INDEX is a programmable input that can be driven directly by the Index output of an incremental encoder. It can be programmed via the MDR to function as one of the following:

LCNTR (load CNTR with data from DTR), RCNTR (reset CNTR), or LOTR (load OTR with data from CNTR). Alternatively, the INDEX input can be masked out for "no functionality".

In quadrature mode, the INDEX input is validated with the filter clock in order to synchronize with the quadrature inputs A and B. To be valid, the INDEX signal in quadrature mode must overlap the condition in which both A and B are low or both A and B are high. In non-quadrature mode, however, the INDEX input is instantaneous in nature and totally independent of A and B.

fck_i (Pin 2), fck₀ (Pin 1)

Input, Output. A crystal connected between these 2 pins generates the basic clock for filtering the A, B and INDEX inputs in the quadrature count mode. Instead of a crystal the fck_i input may also be driven by an external clock.

The frequency at the fck_i input is either divided by 2 (if MDR0 <B7> = 1) or divided by 1 (if MDR0 <B7> = 0) for the filter circuit. For proper filtering of the A, B and the Index inputs the following condition must be satisfied:

$$f_r \geq 4f_{QA}$$

Where f_r is the internal filter clock frequency derived from the fck_i in accordance with the status of MDR0 <B7> and f_{QA} is the maximum frequency of Clock A in quadrature mode.

In non-quadrature count mode, fck_i is not used and should be tied off to any stable logic state.

SS/ (Pin 4)

A high to low transition at the SS/ (Slave Select) input selects the LS7366 for serial bi-directional data transfer; a low to high transition disables serial data transfer and brings the MISO output to high impedance state. This allows for the accommodation of multiple slave units on the serial I/O.

CNT_EN (Pin 12)

Input. Counting is enabled when CNT_EN input is high; counting is disabled when this input is low. There is an internal pull-up resistor on this input.

LFLAG/ (Pin 8), DFLAG/ (Pin 9)

Outputs. LFLAG/ and DFLAG/ are programmable outputs to flag the occurrences of Carry (counter overflow), Borrow (counter underflow), Compare (CNTR = DTR) and INDEX. The LFLAG/ is an open drain latched output. In contrast, the DFLAG/ is a push-pull instantaneous output. The LFLAG/ can be wired in multi-slave configuration, forming a single processor interrupt line. When active LFLAG/ switches to logic 0 and can be restored to the high impedance state only by clearing the status register, STR. In contrast, the DFLAG/ dynamically switches low with occurrences of Carry, Borrow, Compare and INDEX conditions.

The configuration of LFLAG/ and DFLAG/ are made through the control register MDR1. In free-running count mode LFLAG/ and DFLAG/ output the same status information in latched and dynamic form, respectively. In single-cycle mode the DFLAG/ outputs CY and BW signals independent of the MDR1 configuration. In range-limit and modulo-n modes, DFLAG/ outputs CMP signal in count-up direction (at CNTR = DTR) and BW signal when CNTR underflows independent of the MDR1 configuration. In effect, DFLAG/ generates mode-relevant marker signals in all modes, excepting the free-running count mode wherein MDR1 configures the output signal selection.

MOSI (RXD) (Pin 7)

Input. Serial output data from the host processor is shifted into the LS7366 at this input.

MISO (TXD) (Pin 6)

Output. Serial output data from the LS7366 is shifted out on the MISO (Master In Slave Out) pin. The MISO output goes into high impedance state when SS/ input is at logic high, providing multiple slave-unit serial outputs to be wire-ORed.

SCK (Pin 5)

Input. The SCK input serves as the shift clock input for transmitting data in and out of LS7366 on the MOSI and the MISO pins, respectively. Since the LS7366 can operate only in the slave mode, the SCK signal is provided by the host processor as a means for synchronizing the serial transmission between itself and the slave LS7366.

REGISTERS:

The following is a list of LS7366 internal registers:

Upon power-up the registers DTR, CNTR, STR, MDR0 and MDR1 are reset to zero.

DTR. The DTR is a software configurable 8, 16, 24 or 32-bit input data register which can be written into directly from MOSI, the serial input. The DTR data can be transferred into the 32-bit counter (CNTR) under program control or by hardware index signal. The DTR can be cleared to zero by software control. In certain count modes, such as modulo-n and range-limit, DTR holds the data for "n" and the count range, respectively. In compare operations, whereby compare flag is set, the DTR is compared with the CNTR.

CNTR. The CNTR is a software configurable 8, 16, 24 or 32-bit up/down counter which counts the up/down pulses resulting from the quadrature clocks applied at the A and B inputs, or alternatively, in non-quadrature mode, pulses applied at the A input. By means of IR instructions the CNTR can be cleared, loaded from the DTR or in turn, can be transferred into the OTR. The “clear CNTR” and the “load CNTR” commands in the “range-limit” mode, however have limitations. In this mode when the CNTR is frozen in up count direction at CNTR = DTR, a “clear CNTR” command will only function if the count direction is reversed from up to down. Similarly, in the down direction at CNTR = 0, a “load CNTR” command will only function if the direction is reversed from down to up.

OTR. The OTR is a software configuration 8, 16, 24 or 32-bit register which can be read back on the MISO output. Since instantaneous CNTR value is often needed to be read while the CNTR continues to count, the OTR serves as a convenient dump site for instantaneous CNTR data which can then be read without interfering with the counting process.

STR. The STR is an 8-bit status register which stores count related status information.

CY	BW	CMP	IDX	CEN	PLS	U/D	S
7	6	5	4	3	2	1	0

CY: Carry (CNTR overflow) latch
 BW: Borrow (CNTR underflow) latch
 CMP: Compare (CNTR = DTR) latch
 IDX: Index latch
 CEN: Count enable status: 0: counting disabled, 1: counting enabled

PLS: Power loss indicator latch; set upon power up
 U/D: Count direction indicator: 0: count down, 1: count up
 S: Sign bit. 1: negative, 2: positive

A “CLR STR” command to IR resets all status bits except CEN and U/D. In quadrature mode, if the quadrature clocks have been halted, the status bits CY, BW and CMP are not affected by a “CLR STR” command under the following conditions:

CY: If CNTR = FFFFFFFF with status bit U/D = 1
 BW: If CNTR = 0 with status bit U/D = 0
 CMP: If CNTR = DTR

In non-quadrature mode the same rules apply if input A is held at logic low.

IR. The IR is an 8-bit register that fetches instruction bytes from the received data stream and executes them to perform such functions as setting up the operating mode for the chip (load the MDR) and data transfer among the various registers.

B7	B6	B5	B4	B3	B2	B1	B0
----	----	----	----	----	----	----	----

B2 B1 B0 = XXX (Don't care)
 B5 B4 B3 = 000: Select none
 = 001: Select MDR0
 = 010: Select MDR1
 = 011: Select DTR
 = 100: Select CNTR
 = 101: Select OTR
 = 110: Select STR
 = 111: Select none
 B7 B6 = 00: CLR register
 = 01: RD register
 = 10: WR register
 = 11: LOAD register

The actions of the four functions, CLR, RD, WR and LOAD are elaborated in Table 1.

TABLE 1			
Number of Bytes	OP Code	Register	Operation
1	CLR	MDR0	Clear MDR0 to zero
		MRD1	Clear MDR1 to zero
		DTR	None
		CNTR	Clear CNTR to zero
		OTR	None
2 to 5	RD	STR	Clear STR to zero
		MDR0	Output MDR0 serially on TXD (MISO)
		MDR1	Output MDR1 serially on TXD (MISO)
		DTR	None
		CNTR	Transfer CNTR to OTR, then output OTR serially on TXD (MISO)
2 to 5	WR	OTR	Output OTR serially on TXD (MISO)
		STR	Output STR serially on TXD (MISO)
		MDR0	Write serial data at RXD (MOSI) into MDR0
		MDR1	Write serial data at RXD (MOSI) into MDR1
		DTR	Write serial data at RXD (MOSI) into DTR
1	LOAD	CNTR	None
		OTR	None
		STR	None
		MDR0	None
		MDR1	None
1	LOAD	DTR	None
		CNTR	Transfer DTR to CNTR in “parallel”
		OTR	Transfer CNTR to OTR in “parallel”

MDR0. The MDR0 (Mode Register 0) is an 8-bit read/write register that sets up the operating mode for the LS7366. The MDR0 is written into by executing the "write-to-MDR0" instruction via the instruction register. Upon power up MDR0 is cleared to zero. The following is a breakdown of the MDR bits:

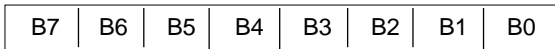

- B1 B0 = 00: non-quadrature count mode. (A = clock, B = direction).
- = 01: x1 quadrature count mode (one count per quadrature cycle).
- = 10: x2 quadrature count mode (two counts per quadrature cycle).
- = 11: x4 quadrature count mode (four counts per quadrature cycle).

- B3 B2 = 00: free-running count mode.
- = 01: single-cycle count mode (counter disabled with carry or borrow, re-enabled with reset or load).
- = 10: range-limit count mode (up and down count-ranges are limited between DTR and zero, respectively; counting freezes at these limits but resumes when direction reverses).
- = 11: modulo-n count mode (input count clock frequency is divided by a factor of (n+1), where n = DTR, in both up and down directions).

- B5 B4 = 00: disable index.
- = 01: configure index as the "load CNTR" input (transfers DTR to CNTR).
- = 10: configure index as the "reset CNTR" input (clears CNTR to 0).
- = 11: configure index as the "load OTR" input (transfers CNTR to OTR).

- B6 = 0: Negative index input
- = 1: Positive index input
- B7 = 0: Filter clock division factor = 1
- = 1: Filter clock division factor = 2

MDR1. The MDR1 (Mode Register 1) is an 8-bit read/write register which is appended to MDR0 for additional modes. Upon power-up MDR1 is cleared to zero.

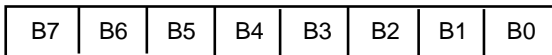

- B1 B0 = 00: 4-byte counter mode
- = 01: 3-byte counter mode
- = 10: 2-byte counter mode.
- = 11: 1-byte counter mode

- B2 = 0: Enable counting
- = 1: Disable counting
- B3 = : not used
- B4 = 0: NOP
- = 1: FLAG on IDX (B4 of STR)
- B5 = 0: NOP
- = 1: FLAG on CMP (B5 of STR)
- B6 = 0: NOP
- = 1: FLAG on BW (B6 of STR)
- B7 = 0: NOP
- = 1: FLAG on CY (B7 of STR)

NOTE: Applicable to both LFLAG/ and DFLAG/

ABSOLUTE MAXIMUM RATINGS: (All voltages referenced to Vss)

Parameter	Symbol	Values	Unit
DC Supply Voltage	V _{DD}	+7.0	V
Voltage	V _{IN}	V _{SS} - 0.3 to V _{DD} + 0.3	V
Operating Temperature	T _A	-25 to +85	°C
Storage Temperature	T _{STG}	-65 to +150	°C

DC Electrical Characteristics. (TA = -25°C to +85°C)

Parameter	Symbol	Min.	TYP	Max.	Unit	Remarks
Supply Voltage	VDD	3.0	-	5.5	V	-
Supply Current	IDD	300	400	450	μA	VDD = 3.0V
	IDD	700	800	950	μA	VDD = 5.0V
Input Voltages						
fcki, Logic high	VCH	-	2.1	2.3	V	VDD = 3.0V
	VCH	-	3.5	3.7	V	VDD = 5.0V
fcki, Logic Low	VCL	0.7	0.9	-	V	VDD = 3.0V
	VCL	1.3	1.5	-	V	VDD = 5.0V
All other inputs, Logic High	VAH	-	1.9	2.1	V	VDD = 3.0V
	VAH	-	3.2	3.5	V	VDD = 5.0V
All other inputs, Logic Low	VAL	0.5	0.7	-	V	VDD = 3.0V
	VAL	1.0	1.2	-	V	VDD = 5.0V
Input Currents:						
CNT_EN Low	IIEL	-	3.0	5.0	μA	VAL = 0.7V, VDD = 3.0V
	IIEL	-	10.0	15.0	μA	VAL = 1.2V, VDD = 5.0V
CNT_EN High	IIEH	-	1.0	3.0	μA	VAH = 1.9V, VDD = 3.0V
	IIEH	-	4.0	6.0	μA	VAH = 3.2V, VDD = 5.0V
All other inputs, High or Low	-	-	0	0	μA	-
Output Currents:						
FLAG Sink	IOFL	-1.3	-2.0	-	mA	VOUT = 0.5V, VDD = 3.0V
	IOFL	-3.2	-4.0	-	mA	VOUT = 0.5V, VDD = 5.0V
FLAG Source	-	0	0	-	mA	Open Drain Output
fckO Sink	IOCL	-1.3	-2.0	-	mA	VOUT = 0.5V, VDD = 3.0V
	IOCL	-3.2	-4.0	-	mA	VOUT = 0.5V, VDD = 5.0V
fckO Source	IOCH	1.3	2.0	-	mA	VOUT = 2.5V, VDD = 3.0V
	IOCH	3.2	4.0	-	mA	VOUT = 4.5V, VDD = 5.0V
TXD/MISO:						
Sink	IOML	-1.5	-2.4	-	mA	VOUT = 0.5V, VDD = 3.0V
	IOML	-3.8	-4.8	-	mA	VOUT = 0.5V, VDD = 5.0V
Source	IOMH	1.5	2.4	-	mA	VOUT = 0.5V, VDD = 3.0V
	IOMH	3.8	4.8	-	mA	VOUT = 0.5V, VDD = 5.0V

Transient Characteristics. (TA = -25°C to +85°C, VDD = 5V ± 10%)

Parameter	Symbol	Min. Value	Max. Value	Unit	Remarks
(See Fig. 2 & 3)					
SCK High Pulse Width	tCH	100	-	ns	-
SCK Low Pulse Width	tCL	100	-	ns	-
SS/ Set Up Time	tCSL	100	-	ns	-
SS/ Hold Time	tCSH	100	-	ns	-
Quadrature Mode					
(See Fig. 4, 6 & 7)					
fckI High Pulse Width	t1	12	-	ns	-
fckI Pulse Width	t2	12	-	ns	-
fckI Frequency	f _{CK}	-	40	MHz	-
Effective Filter Clock fF Period	t3	25	-	ns	t3 = t1+t2, MDR0 <7> = 0
	t3	50	-	ns	t3 = 2(t1+t2), MDR0 <7> = 1
Effective Filter Clock fF frequency	fF	-	40	MHz	fF = 1/ t3
Quadrature Separation	t4	26	-	ns	t4 > t3
Quadrature Clock Pulse Width	t5	52	-	ns	t5 > 2t3
Quadrature Clock frequency	fQA, fQB	-	9.6	MHz	fQA = fQB < 1/4t3
Quadrature Clock to Count Delay	tQ1	4t3	5t3	-	-
x1 / x2 / x4 Count Clock Pulse Width	tQ2	12	-	ns	tQ2 = (t3)/2
Index Input Pulse Width	tId	32	-	ns	tId > t4
Index Set Up Time	tIs	-	5	ns	-
Index Hold Time	tIh	-	5	ns	-
Quadrature clock to	tIi	4.5t3	5.5t3	ns	-
DFLAG/ or LFLAG/ delay					
DFLAG/ output width	tIw	26	-	ns	tIw = t4

Parameter	Symbol	Min. Value	Max. Value	Unit	Remarks
Non-Quadrature Mode					
(See Fig. 5 & 8)					
Clock A - High Pulse Width	t6	12	-	ns	-
Clock A - Low Pulse Width	t7	12	-	ns	-
Direction Input B Set-up Time	t8S	12	-	ns	-
Direction Input B Hold Time	t8H	10	-	ns	-
Clock Frequency (non-Mod-N)	fA	-	40	MHz	$f_A = (1/(t_6 + t_7))$
Clock to DFLAG/ or LFLAG/ delay	t9	20	-	ns	-
DFLAG/ output width	t10	12	-	ns	t10 = t7

Transient Characteristics. (TA = -25°C to +85°C, VDD = 3.3V ± 10%)

Parameter	Symbol	Min. Value	Max. Value	Unit	Remarks
(See Fig. 2 & 3)					
SCK High Pulse Width	tCH	120	-	ns	-
SCK Low Pulse Width	tCL	120	-	ns	-
SS/ Set Up Time	tCSL	120	-	ns	-
SS/ Hold Time	tCSH	120	-	ns	-
Quadrature Mode					
(See Fig. 4, 6 & 7)					
fckI High Pulse Width	t1	24	-	ns	-
fckI Pulse Width	t2	24	-	ns	-
fckI Frequency	fCK	-	20	MHz	-
Effective Filter Clock fF Period	t3	50	-	ns	t3 = t1+t2, MDR0 <7> = 0
	t3	100	-	ns	t3 = 2(t1+t2), MDR0 <7> = 1
Effective Filter Clock fF frequency	fF	-	20	MHz	fF = 1/t3
Quadrature Separation	t4	52	-	ns	t4 > t3
Quadrature Clock Pulse Width	t5	105	-	ns	t5 ≥ 2t3
Quadrature Clock frequency	fQA, fQB	-	4.5	MHz	fQA = fQB < 1/4t3
Quadrature Clock to Count Delay	tQ1	4t3	5t3	-	-
x1/x2/x4 Count Clock Pulse Width	tQ2	25	-	ns	tQ2 = (t3)/2
Index Input Pulse Width	tID	60	-	ns	tID > t4
Index Set Up Time	tIS	-	10	ns	-
Index Hold Time	tIH	-	10	ns	-
Quadrature clock to DFLAG/ or LFLAG/ delay	tI1	4.5t3	5.5t3	ns	-
DFLAG/ output width	tIw	52	-	ns	tIw = t4

Non-Quadrature Mode					
(See Fig. 5 & 8)					
Clock A - High Pulse Width	t6	24	-	ns	-
Clock A - Low Pulse Width	t7	24	-	ns	-
Direction Input B Set-up Time	t8S	24	-	ns	-
Direction Input B Hold Time	t8H	24	-	ns	-
Clock Frequency (non-Mod-N)	fA	-	40	MHz	$f_A = (1/(t_6 + t_7))$
Clock to DFLAG/or LFLAG/ delay	t9	40	-	ns	-
DFLAG/ output width	t10	24	-	ns	t10 = t7

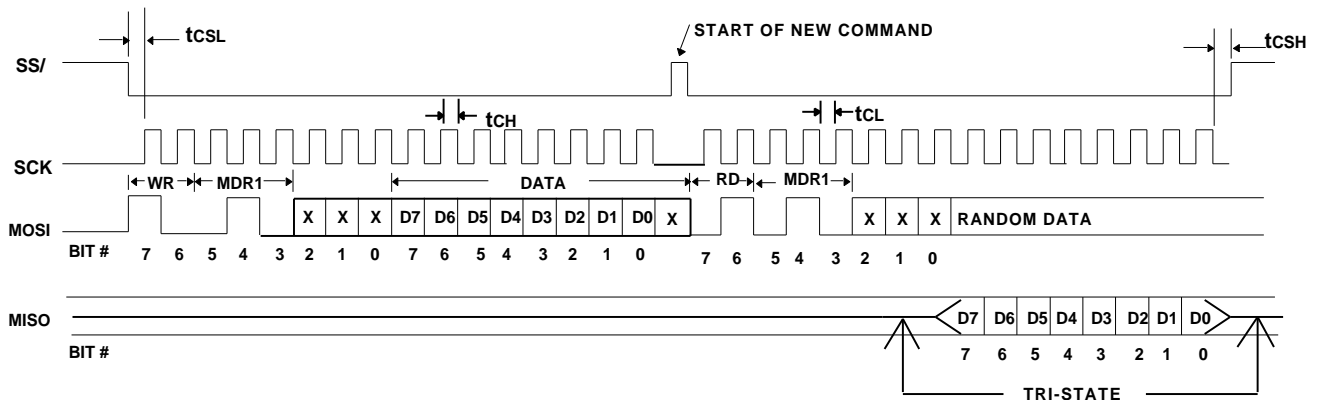

NOTE: Write to MDR1 followed by Read from MDR1 operation

FIGURE 2. WR MDR1 - RD MDR1

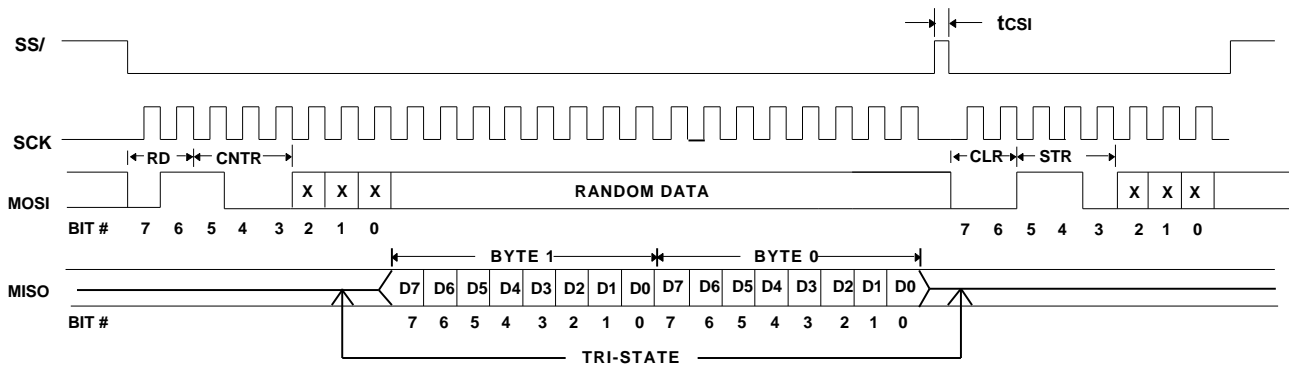

NOTE: Read CNTR (in 2-byte configuration) followed by CLR STR operation.

FIGURE 3. RD CNTR - CLR STR

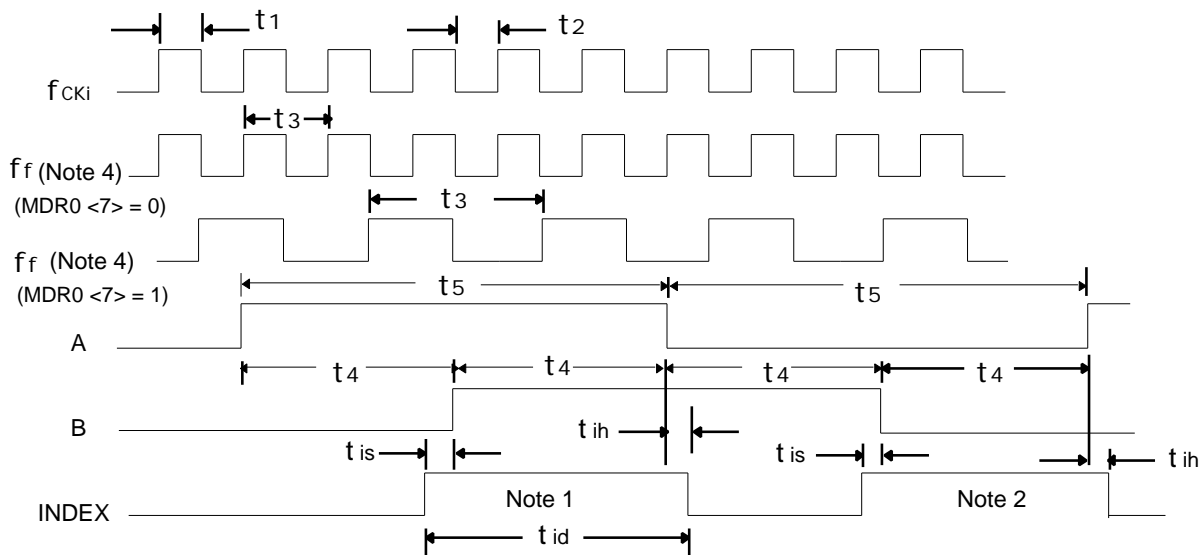

- Note 1. Positive index coincident with both A and B high.
- Note 2. Positive index coincident with both A and B low.
- Note 3. The index logic level in the above examples are inverted for negative index.
- Note 4. ff is the internal effective filter clock.

FIGURE 4. fcki, A, B and INDEX

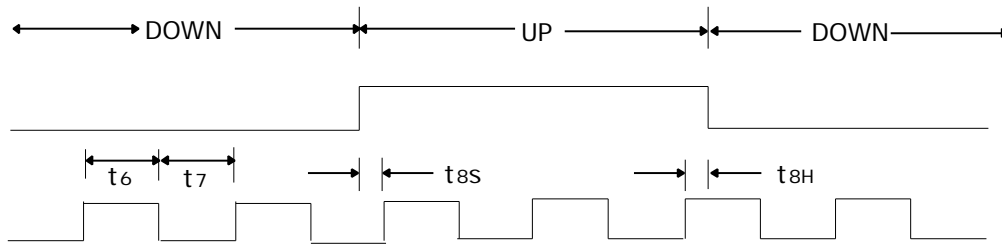
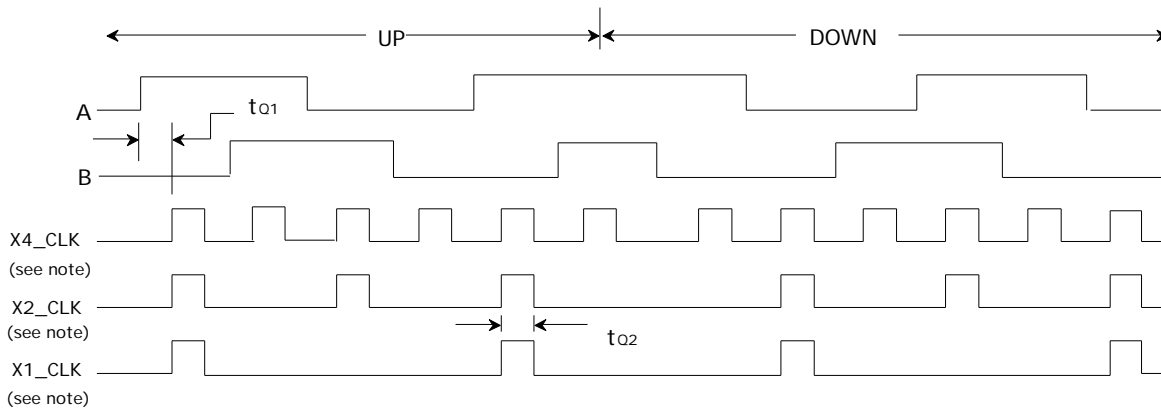
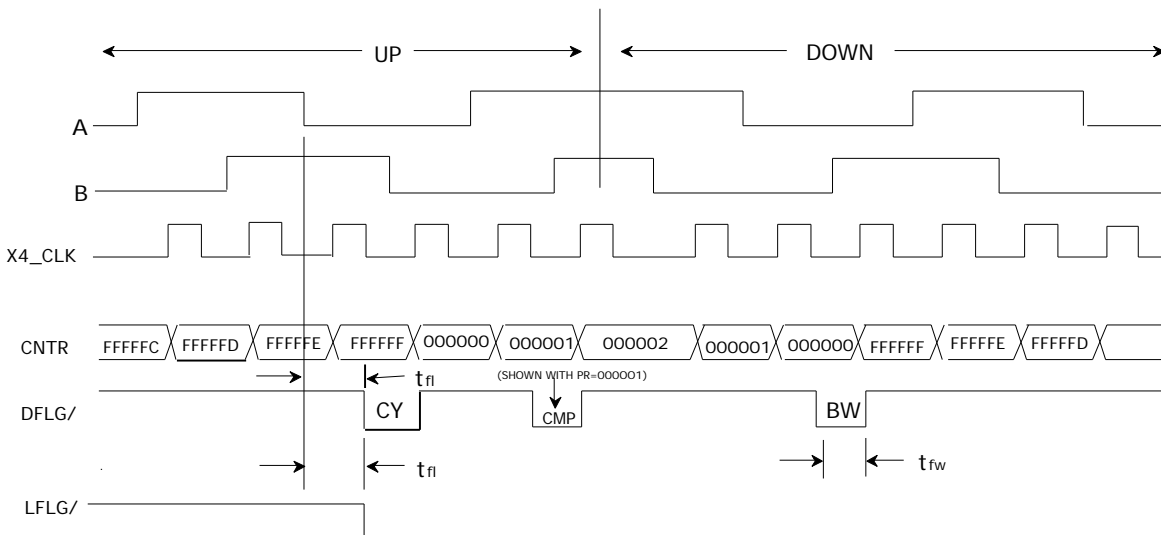

FIGURE 5. COUNT (A) AND DIRECTION (B) INPUTS IN NON-QUADRATURE MODE



Note: x1, x2, and x4 CLKs are internal up/down clocks derived from filtered and decoded quadrature clocks.

FIGURE 6. A/B QUADRATURE CLOCKS vs INTERNAL COUNT CLOCKS



Note: CNTR values are indicated in 3-byte mode

FIGURE 7. QUADRATURE CLOCKS vs FLAG OUTPUTS

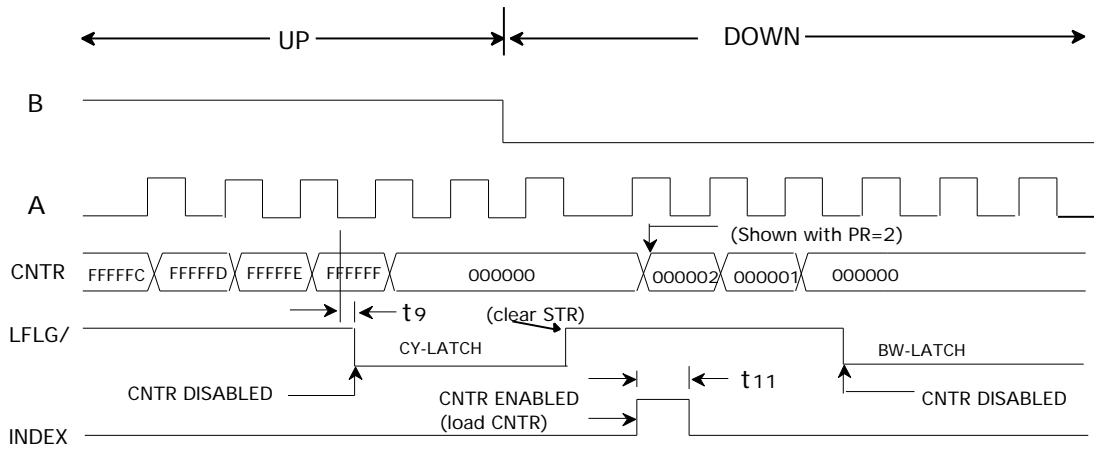

NOTE: CNTR values are indicated in 2-byte mode

FIGURE 8. SINGLE-CYCLE, NON-QUADRATURE

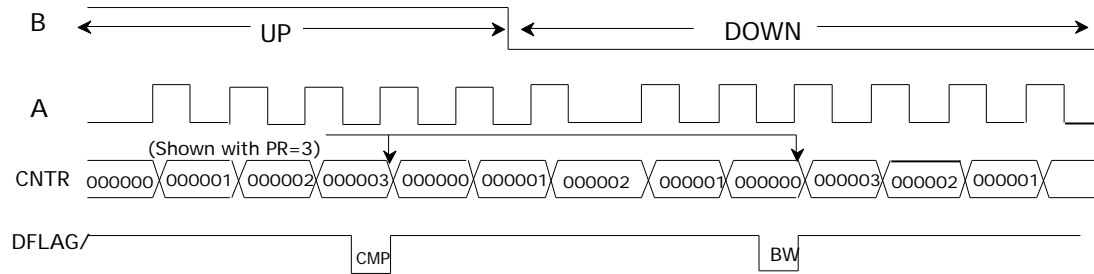

NOTE: CNTR values are indicated in 1-byte mode

FIGURE 9. MODULO-N, NON-QUADRATURE

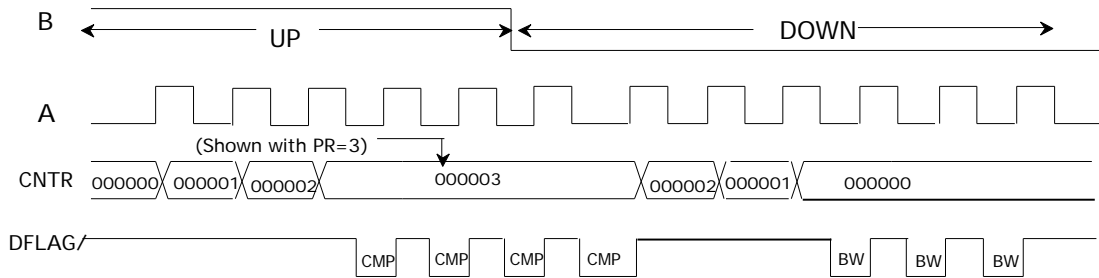

NOTE: CNTR values are indicated in 1-byte mode

FIGURE 10. RANGE-LIMIT, NON-QUADRATURE

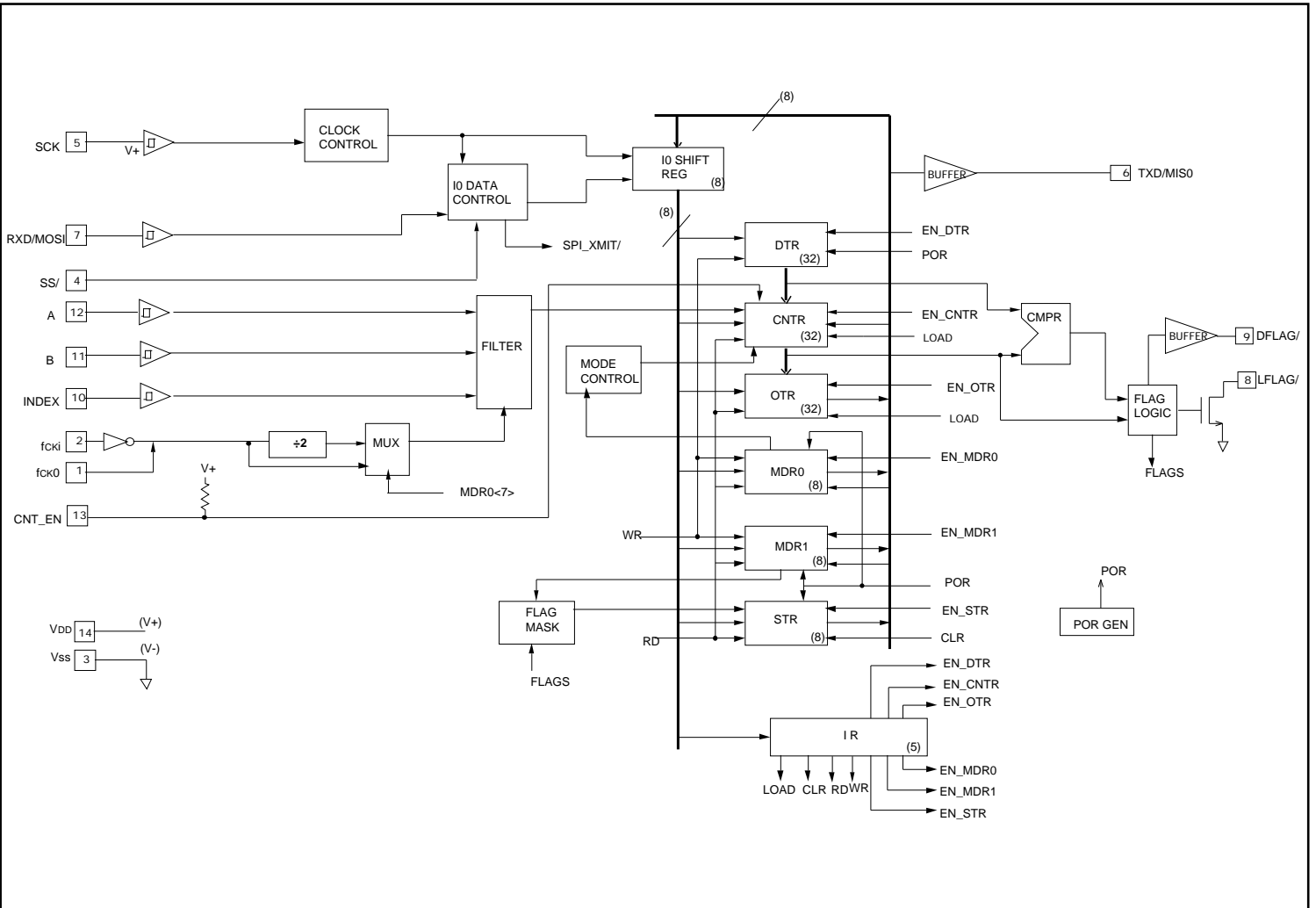

FIGURE 11. LS7366 BLOCK DIAGRAM

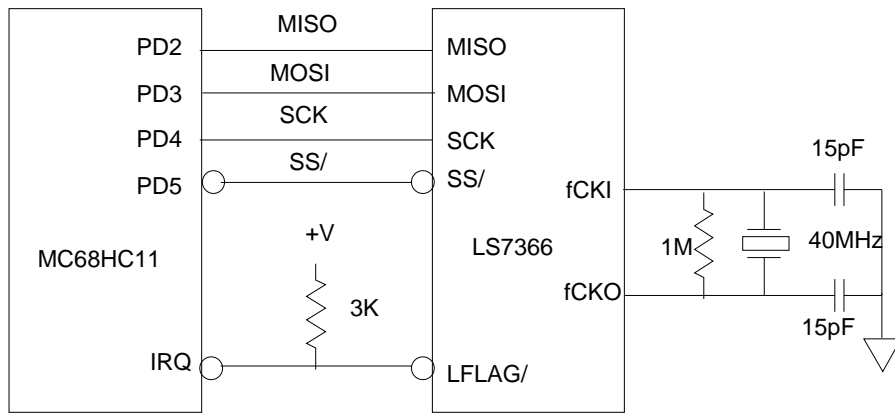

FIGURE 12. LS7366 TO MC68H11 SPI PORT INTERFACE