

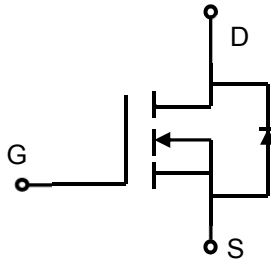

## Lonten N-channel 600V, 11A, 0.35Ω LonFET™ Power MOSFET

<p><b>Description</b></p> <p>LonFET™ Power MOSFET is fabricated using advanced super junction technology. The resulting device has extremely low on resistance, making it especially suitable for applications which require superior power density and outstanding efficiency.</p> <p><b>Features</b></p> <ul style="list-style-type: none"> <li>◆ Ultra low <math>R_{dson}</math></li> <li>◆ Ultra low gate charge (typ. <math>Q_g = 34nC</math>)</li> <li>◆ 100% UIS tested</li> <li>◆ RoHS compliant</li> </ul>	<p><b>Product Summary</b></p> <table> <tr> <td><math>V_{DS} @ T_{j,max}</math></td> <td>650V</td> </tr> <tr> <td><math>R_{DS(ON),max}</math></td> <td>0.35Ω</td> </tr> <tr> <td><math>I_{DM}</math></td> <td>30A</td> </tr> <tr> <td><math>Q_{g,typ}</math></td> <td>34nC</td> </tr> </table> <div style="text-align: center;">  <p>N-Channel MOSFET</p> </div> <div style="text-align: right;">  </div>	$V_{DS} @ T_{j,max}$	650V	$R_{DS(ON),max}$	0.35Ω	$I_{DM}$	30A	$Q_{g,typ}$	34nC
$V_{DS} @ T_{j,max}$	650V								
$R_{DS(ON),max}$	0.35Ω								
$I_{DM}$	30A								
$Q_{g,typ}$	34nC								

### Absolute Maximum Ratings

Parameter	Symbol	LSC11N60	Unit
Drain-Source Voltage	$V_{DSS}$	600	V
Continuous drain current ( $T_C = 25^\circ C$ ) ( $T_C = 100^\circ C$ )	$I_D$	11	A
		7	A
Pulsed drain current <sup>1)</sup>	$I_{DM}$	30	A
Gate-Source voltage	$V_{GSS}$	$\pm 30$	V
Avalanche energy, single pulse <sup>2)</sup>	$E_{AS}$	350	mJ
Avalanche energy, repetitive <sup>1)</sup>	$E_{AR}$	12.5	mJ
Avalanche current, repetitive <sup>1)</sup>	$I_{AR}$	11	A
Power Dissipation ( $T_C = 25^\circ C$ ) - Derate above $25^\circ C$	$P_D$	125	W
		1	W/ $^\circ C$
Operating and Storage Temperature Range	$T_J, T_{STG}$	-55 to +150	$^\circ C$
Continuous diode forward current	$I_S$	11	A
Diode pulse current	$I_{S,pulse}$	30	A

### Thermal Characteristics

Parameter	Symbol	LSC11N60	Unit
Thermal Resistance, Junction-to-Case	$R_{\theta JC}$	1	$^\circ C/W$
Thermal Resistance, Junction-to-Ambient	$R_{\theta JA}$	62.5	$^\circ C/W$

## Package Marking and Ordering Information

Device	Device Package	Marking
LSC11N60	TO-220	LSC11N60

## Electrical Characteristics T<sub>c</sub> = 25°C unless otherwise noted

Parameter	Symbol	Test Condition	Min.	Typ.	Max.	Unit
<b>Static characteristics</b>						
Drain-source breakdown voltage	BV <sub>DSS</sub>	V <sub>GS</sub> =0 V, I <sub>D</sub> =0.25 mA	600	-	-	V
Gate threshold voltage	V <sub>GS(th)</sub>	V <sub>DS</sub> =V <sub>GS</sub> , I <sub>D</sub> =0.25mA	2	-	5	V
Drain cut-off current	I <sub>DSS</sub>	V <sub>DS</sub> =600 V, V <sub>GS</sub> =0 V,	-	-	1	μA
Gate leakage current, Forward	I <sub>GSSF</sub>	V <sub>GS</sub> =30 V, V <sub>DS</sub> =0 V	-	-	100	nA
Gate leakage current, Reverse	I <sub>GSSR</sub>	V <sub>GS</sub> =-30 V, V <sub>DS</sub> =0 V	-	-	-100	nA
Drain-source on-state resistance	R <sub>DS(on)</sub>	V <sub>GS</sub> =10 V, I <sub>D</sub> =5.5 A T <sub>j</sub> = 25°C T <sub>j</sub> = 150°C	-	0.3 0.69	0.35 -	Ω
Gate resistance	R <sub>G</sub>	f=1 MHz, open drain	-	0.9	-	Ω
<b>Dynamic characteristics</b>						
Input capacitance	C <sub>iss</sub>	V <sub>DS</sub> = 25 V, V <sub>GS</sub> = 0 V,	-	1040	-	pF
Output capacitance	C <sub>oss</sub>	f = 1 MHz	-	780	-	
Reverse transfer capacitance	C <sub>rss</sub>		-	10	-	
Turn-on delay time	t <sub>d(on)</sub>	V <sub>DD</sub> = 300V, I <sub>D</sub> = 5.5A	-	34	-	ns
Rise time	t <sub>r</sub>	R <sub>G</sub> = 4.7Ω, V <sub>GS</sub> =10V	-	141	-	
Turn-off delay time	t <sub>d(off)</sub>		-	42	-	
Fall time	t <sub>f</sub>		-	46	-	
<b>Gate charge characteristics</b>						
Gate to source charge	Q <sub>gs</sub>	V <sub>DD</sub> =480 V, I <sub>D</sub> =5.5A,	-	15	-	nC
Gate to drain charge	Q <sub>gd</sub>	V <sub>GS</sub> =0 to 10 V	-	8	-	
Gate charge total	Q <sub>g</sub>		-	34	-	
Gate plateau voltage	V <sub>plateau</sub>		-	5.4	-	V
<b>Reverse diode characteristics</b>						
Diode forward voltage	V <sub>SD</sub>	V <sub>GS</sub> =0 V, I <sub>F</sub> =5.5A	-	-	1.4	V
Reverse recovery time	t <sub>rr</sub>	V <sub>R</sub> =50 V, I <sub>F</sub> =11A,	-	439	-	ns
Reverse recovery charge	Q <sub>rr</sub>	di <sub>F</sub> /dt=100 A/μs	-	3.6	-	μC
Peak reverse recovery current	I <sub>rrm</sub>		-	15	-	A

### Notes:

1. Repetitive Rating: Pulse width limited by maximum junction temperature
2. I<sub>AS</sub> = 3.5A, V<sub>DD</sub> = 60V, R<sub>G</sub> = 25Ω, Starting T<sub>J</sub> = 25°C

**Electrical Characteristics Diagrams**

Figure 1. On-Region Characteristics

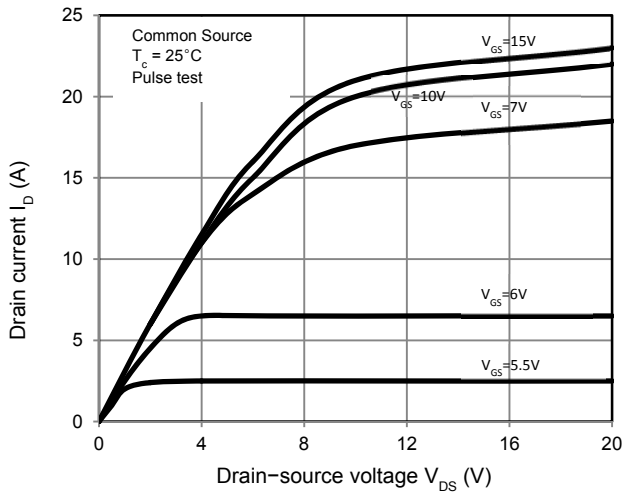

Figure 2. Transfer Characteristics

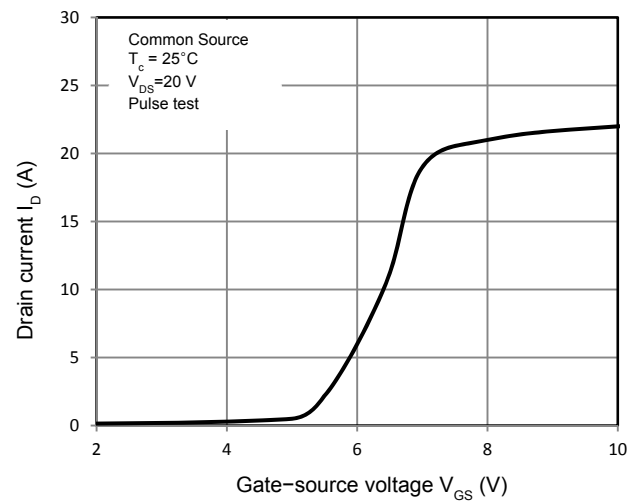

Figure 3. On-Resistance Variation vs. Drain Current

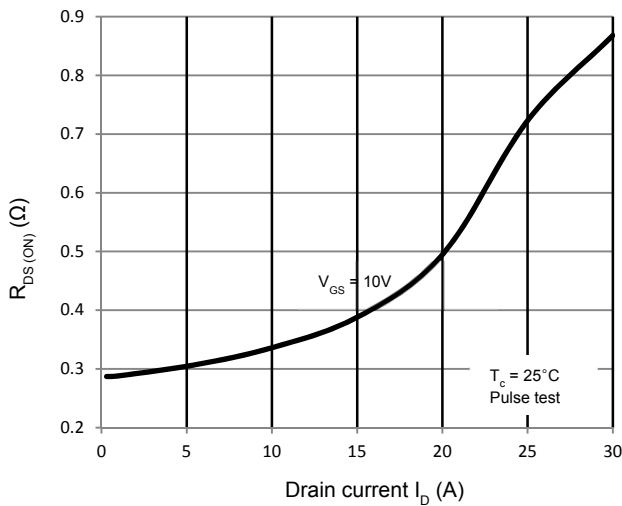

Figure 4. Threshold Voltage vs. Temperature

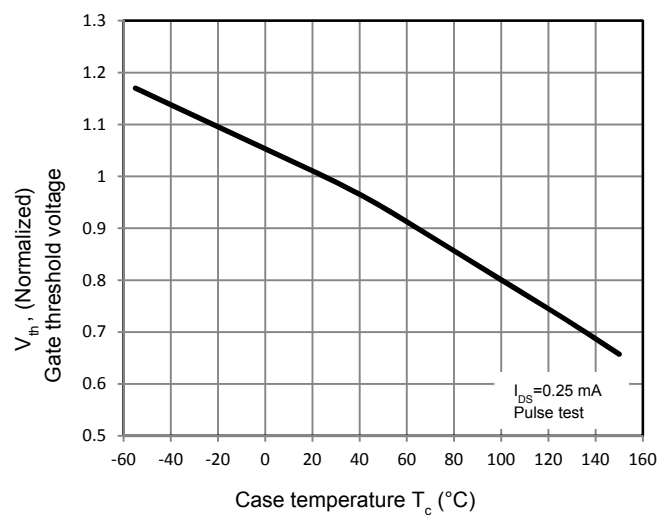

Figure 5. Breakdown Voltage vs. Temperature

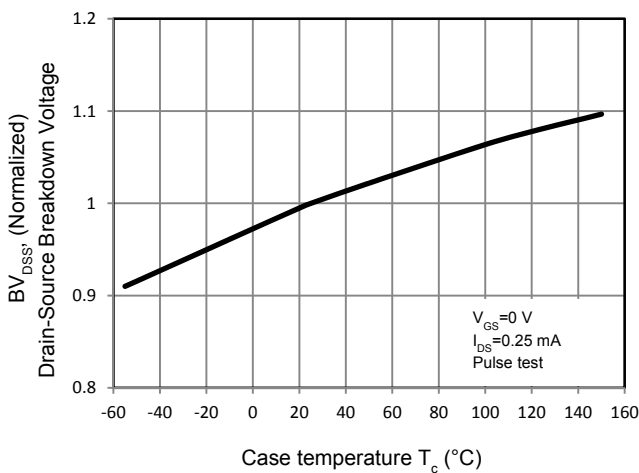

Figure 6. On-Resistance vs. Temperature

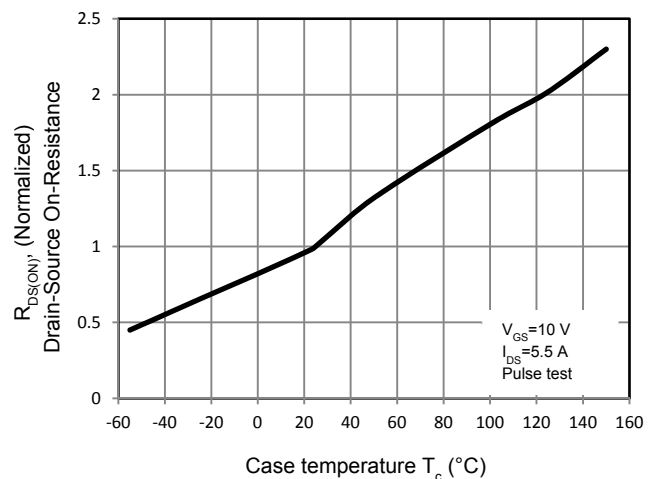

Figure 7. Capacitance Characteristics

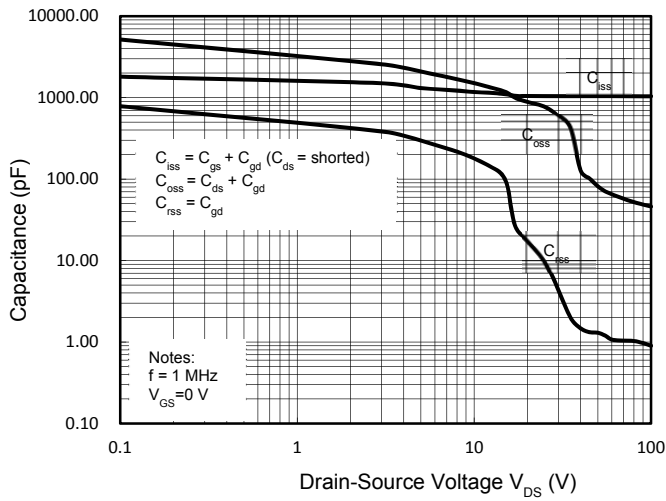

Figure 8. Gate Charge Characteristics

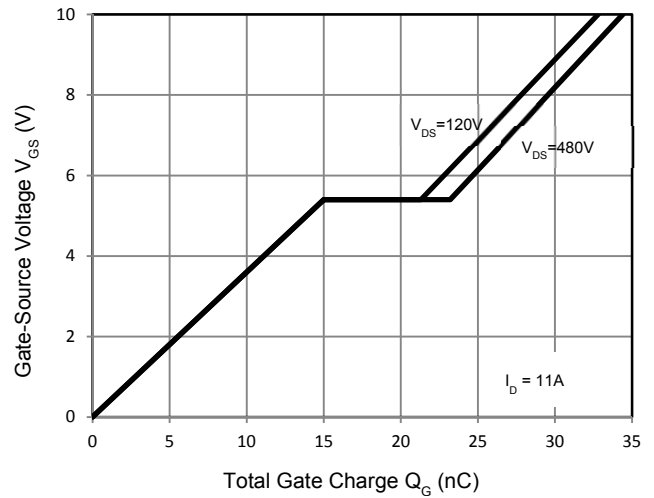

Figure 9. Maximum Safe Operating Area

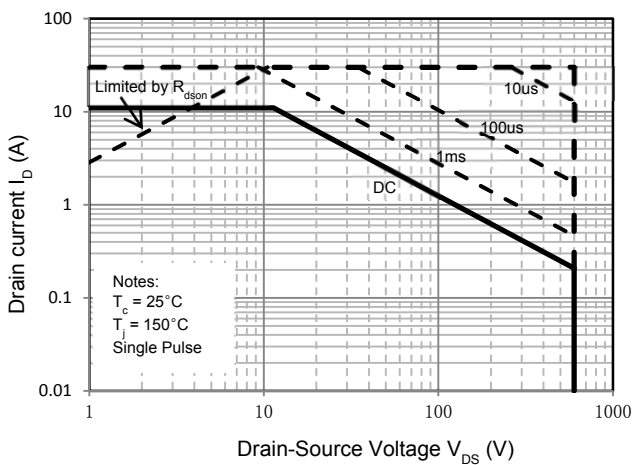

Figure 10. Power Dissipation vs. Temperature

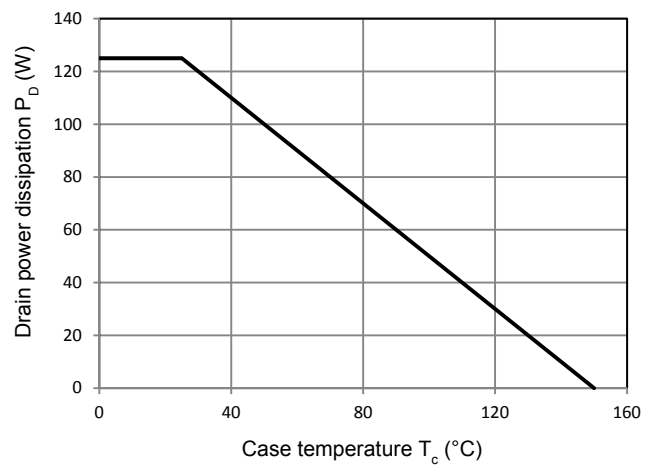
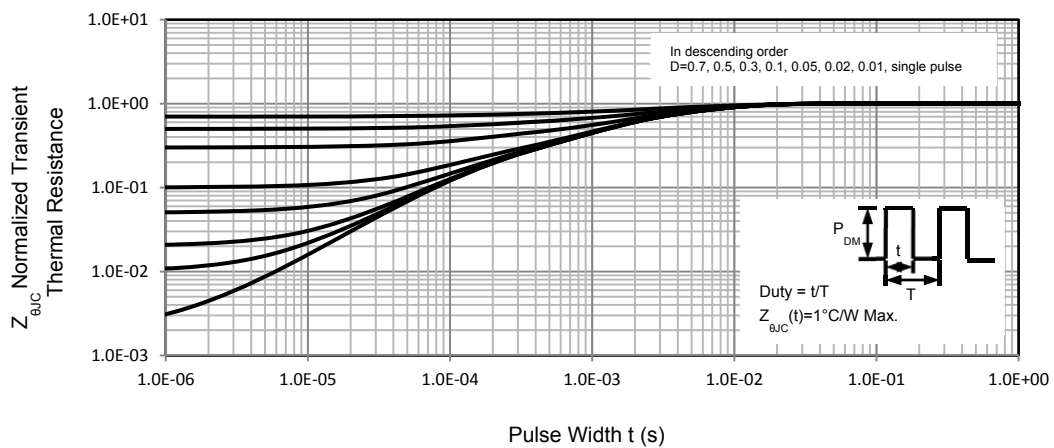
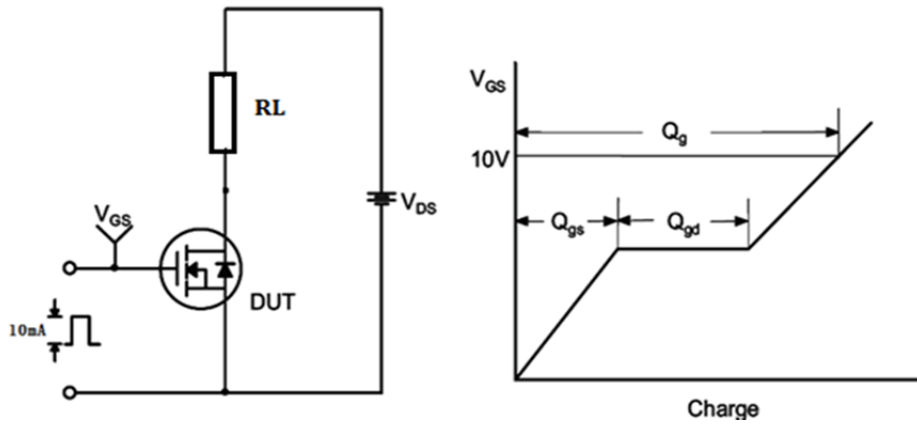

Figure 11. Transient Thermal Response Curve



**Gate Charge Test Circuit & Waveform**



**Switching Test Circuit & Waveforms**

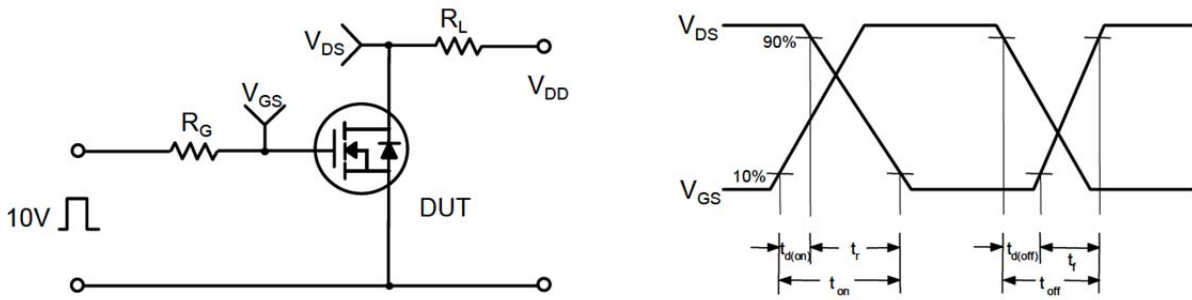

**Unclamped Inductive Switching Test Circuit & Waveforms**

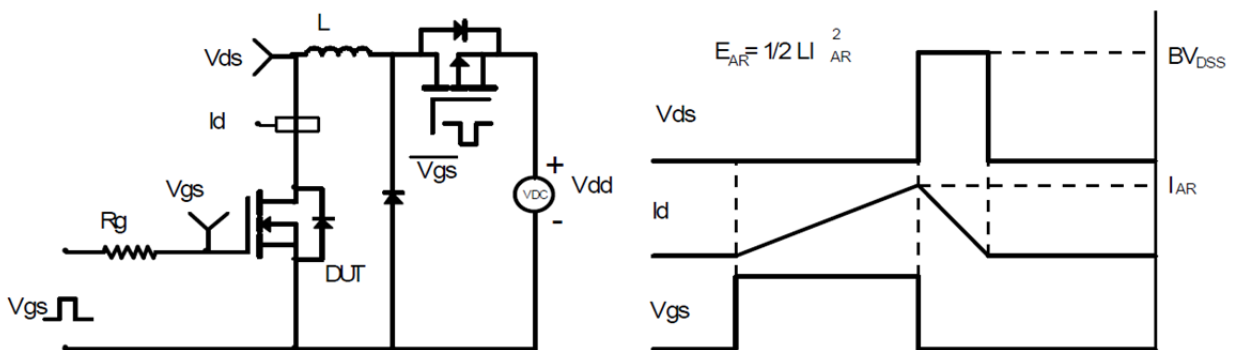

Mechanical Dimensions for TO-220

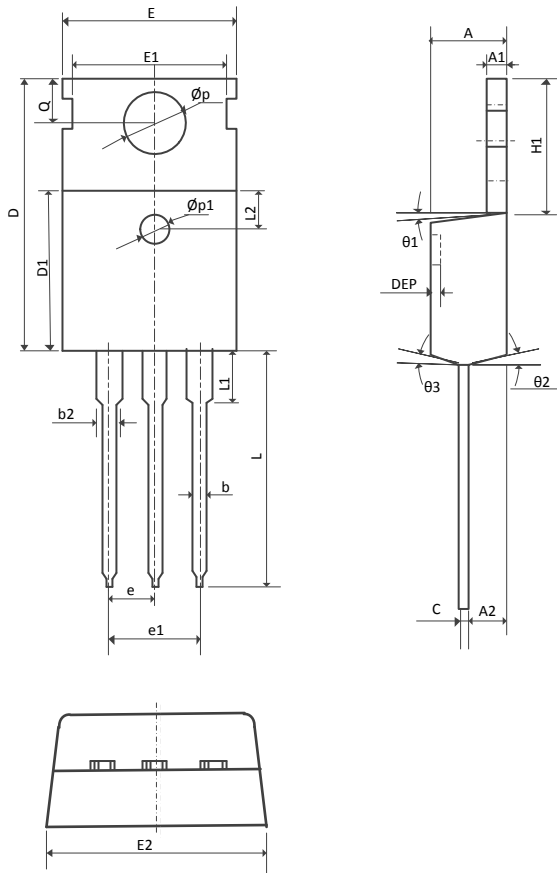

COMMON DIMENSIONS						
SYMBOL	MM			INCH		
	MIN	NOM	MAX	MIN	NOM	MAX
A	4.40	4.57	4.70	0.173	0.180	0.185
A1	1.27	1.30	1.37	0.050	0.051	0.054
A2	2.35	2.40	2.50	0.091	0.094	0.098
b	0.77	0.80	0.90	0.030	0.031	0.035
b2	1.17	1.27	1.36	0.046	0.050	0.054
c	0.48	0.50	0.56	0.019	0.020	0.022
D	15.40	15.60	15.80	0.606	0.614	0.622
D1	9.00	9.10	9.20	0.354	0.358	0.362
DEP	0.05	0.10	0.20	0.002	0.004	0.008
E	9.80	10.00	10.20	0.386	0.394	0.402
E1	-	8.70	-	-	0.343	-
E2	9.80	10.00	10.20	0.386	0.394	0.401
$\phi_{p1}$	1.40	1.50	1.60	0.055	0.059	0.063
e	2.54BSC			0.1BSC		
e1	5.08BSC			0.2BSC		
H1	6.40	6.50	6.60	0.252	0.256	0.260
L	12.75	13.50	13.65	0.502	0.531	0.537
L1	-	3.10	3.30	-	0.122	0.130
L2		2.50REF			0.098REF	
$\phi_p$	3.50	3.60	3.63	0.137	0.142	0.143
Q	2.73	2.80	2.87	0.107	0.110	0.116
$\theta_1$	5°	7°	9°	5°	7°	9°
$\theta_2$	1°	3°	5°	1°	3°	5°
$\theta_3$	1°	3°	5°	1°	3°	5°