

**Samsung Secret**

Product Information

Customer :**DATE : Feb. 20. 2013****SAMSUNG TFT-LCD****MODEL : LSC320AN01*****(TFT Panel + Driver Kit)***

The Information Described in this Specification is Preliminary and can be changed without prior notice

LCD Business

Samsung Electronics Co . , LTD.

MODEL

LSC320AN01

Doc. No

06-003-G-20130220

Page

1 / 24

Contents

Revision History	-----	(3)
General Description	-----	(4)
General Information	-----	(4)
1. Absolute Maximum Ratings	-----	(5)
2. Optical Characteristics	-----	(6)
3. Electrical Characteristics	-----	(9)
3.1 TFT LCD Module		
4. Input Terminal Pin Assignment	-----	(10)
4.1 Input Signal & Power		
4.2 LVDS Interface		
4.3 Input Signals, Basic Display Colors and Gray Scale of Each Color		
5. Interface Timing	-----	(13)
5.1 Timing Parameters (DE only mode)		
5.2 LVDS Input data Characteristic		
5.3 Timing Diagrams of interface Signal (DE only mode)		
5.4 Power ON/OFF Sequence		
6. Outline Dimension	-----	(17)
7. Packing	-----	(18)
8. Marking & Others	-----	(19)
9. General Precaution	-----	(21)
9.1 Handling		
9.2 Storage		
9.3 Operation		
9.4 Operation Condition Guide		
9.5 Others		

**Samsung Secret****Revision History**

Date	Rev. No	Page	Summary
20. Feb. 2013	000	all	First issued

General Description

Samsung Secret

Description

LSC320AN01 is a color active matrix liquid crystal display (LCD) that uses amorphous silicon TFT (Thin Film Transistor) as switching components. This model is composed of a TFT LCD panel, a driver circuit, and an assembly KIT of source PBA. The model has a resolution of a 1366 x 768 and can display up to 16.7 Million colors with wide viewing angle of 89° or higher degree in all directions. This panel is designed applications by providing an excellent performance function of the Flat Panel Display such as Home-alone Multimedia TFT-LCD TV and High Definition TV.

Features

- RoHS compliance (Pb-free)
- High contrast ratio & aperture ratio with wide color gamut
- SVA (Super Vertical Align) mode
- Wide viewing angle ($\pm 178^\circ$)
- High speed response
- FHD resolution (16:9)
- Low Power consumption
- DE (Data Enable) mode
- 2ch LVDS (Low Voltage Differential Signaling) interface

General Information

Items	Specification	Unit	Note
Glass Size	(TFT)713 x 410.5 (CF)713 x 410.5	mm	± 1.0 mm
Polarizer Size	707.9 x 404.9	mm	± 1.0 mm
Weight	1200 (Typ)	g	
Pixel Pitch	0.51075 (H) \times 0.17025 (V)	mm	
Active Display Area	697.6845 (H) X 392.256 (V)	mm	
Surface Treatment	Anti-Glare		
Display Colors	8bit	colors	
Number of Pixels	1366 x 768	pixel	
Pixel Arrangement	RGB Horizontal stripe		
Display Mode	Normally Black		

1. Absolute Maximum Ratings

If the condition exceeds maximum ratings, it can cause malfunction or unrecoverable damage on the device.

Item	Symbol	Min.	Max.	Unit	Note
Power Supply Voltage	V_{DD}	10.8	13.2	V	(1)
Storage temperature	T_{STG}	5	40	°C	(2), (4)
Operating temperature	T_{OPR}	0	50	°C	(2), (5)
Storage humidity	H_{STG}	35	75	%RH	(2), (4)
Operating humidity	H_{STG}	20	90	%RG	(2), (5)
Endurance on static electricity			150	V	(3)

Note (1) $T_a = 25 \pm 2$ °C

(2) Temperature and the range of relative humidity are shown in the figure below.

a. 90 % RH Max. ($T_a \leq 39$ °C)

b. Relative Humidity is 90% or less. ($T_a > 39$ °C)

c. No condensation

(3) Keep the static electricity under 150V in process the polarizer is attached on glass

(4) The storage condition with glass

(5) The operating condition with assembly

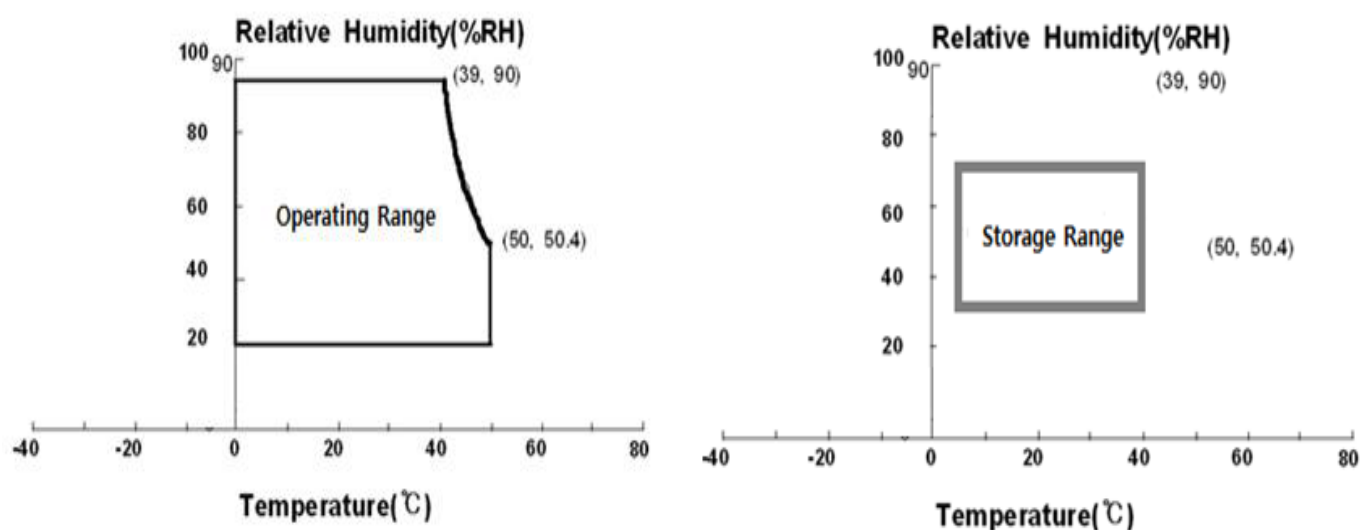

Fig. Temperature and Relative humidity range

2. Optical Characteristics

Samsung Secret

The optical characteristics should be measured in a dark room or the space surrounded by similar setting.

Measuring equipment : TOPCON RD-80S, TOPCON SR-3, ELDIM EZ-Contrast

(Ta = 25 ± 2°C, VDD=12V, fv= 60Hz, f_{DCLK} = 75MHz, **Light source : D65 standard**)

Item	Symbol	Condition	Min.	Typ.	Max.	Unit	Note
Contrast Ratio (Center of screen)	C/R		3000	4000	-		(1) SR-3
Response Time	G-to-G	Tg	-	20	30	msec	(2) RD-80S
Luminance of White (Center of screen)	Y _L		205	230	-	cd/m ²	(3) SR-3
Color Chromaticity (CIE 1931)	Red	Rx	Normal q _{L,R} = 0 q _{U,D} = 0	Viewing Angle	-0.03	+0.03	(4) SR-3
		Ry					
	Green	Gx					
		Gy					
	Blue	Bx					
		By					
	White	Wx					
		Wy					
Color Gamut	-		-	65	-	%	(4) SR-3
Color Temperature	-		-	8000	-	K	

- The characteristics of light source (D65 , The general light source)

- Color Temperature : 6504K
- Wx, Wy : 0.2948, 0.322
- Luminance of white : 3389 cd/m²

Samsung Secret

- Test Equipment Setup

The measurement should be executed in a stable, windless and dark room between 40min and 60min after operating the panel at the given temperature for stabilization of the D65 standard light. This should be measured in the center of screen.

Environment condition : $T_a = 25 \pm 2 \text{ }^\circ\text{C}$

Photo detector	Field
SR-3	2° /1°
RD-80S	1°

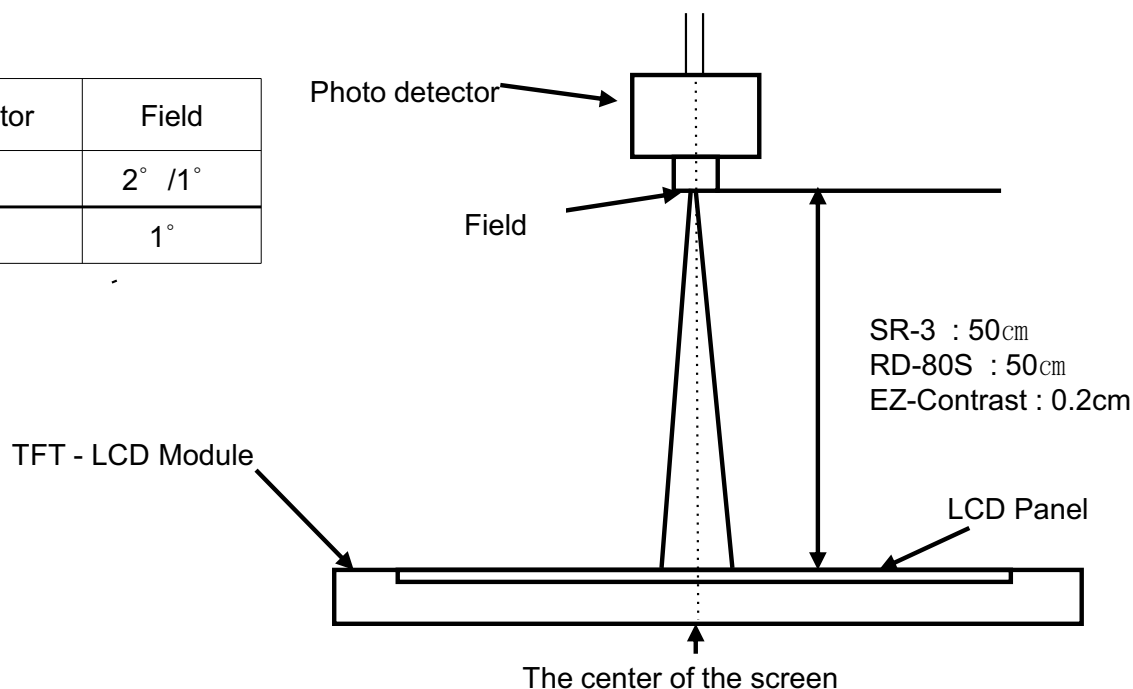

- Definition of test point

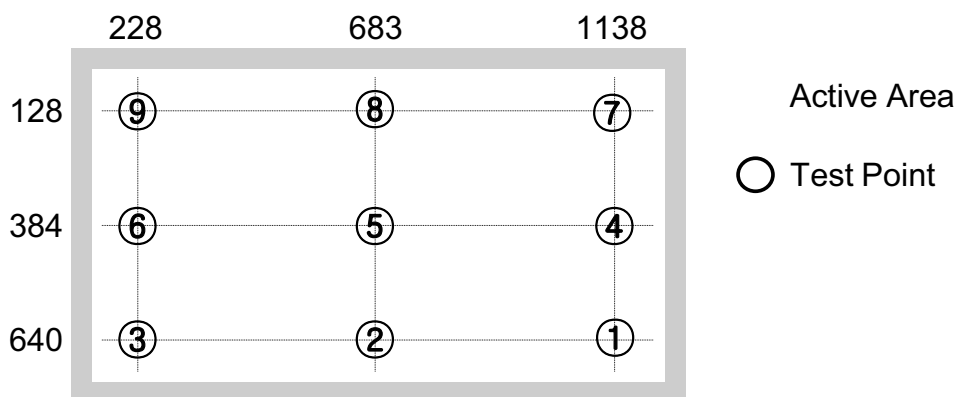

Note (1) Definition of Contrast Ratio (C/R)

: Ratio of gray max (Gmax) & gray min (Gmin) at the center point ⑤ of the panel

$$C/R = \frac{G_{max}}{G_{min}}$$

Gmax : Luminance with all pixels white

Gmin : Luminance with all pixels black

Note (2) Definition of Response time : Sum of Tr, Tf

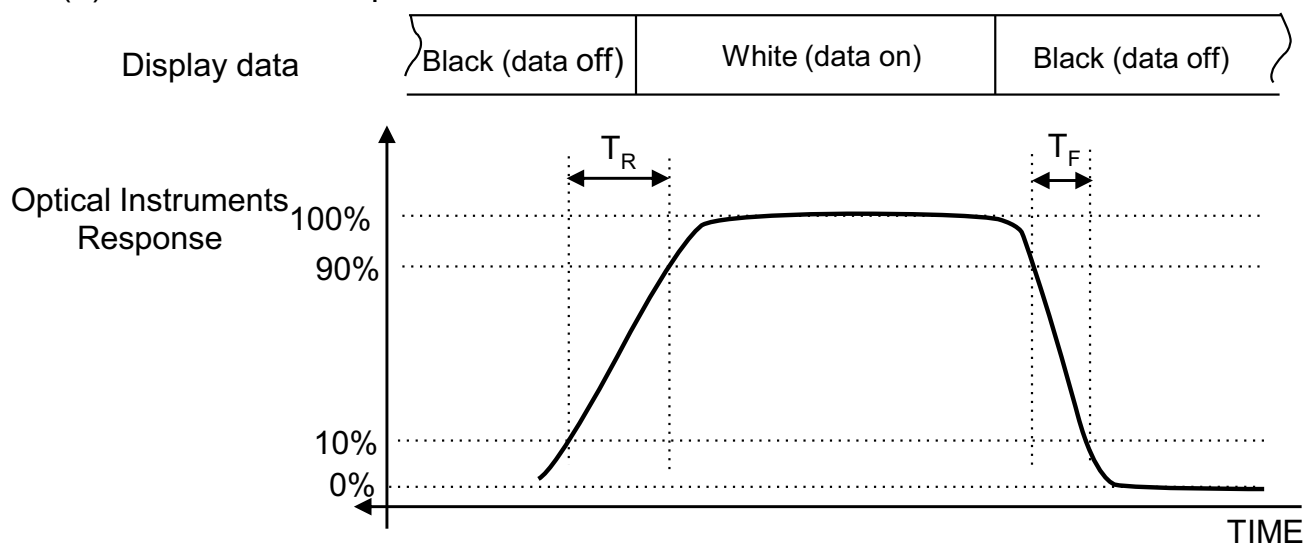

※ G-to-G : Average response time between the whole gray scale to the whole gray scale.†

Gray to Gray Response Time										
Start	Gray	End								
		0	31	63	95	127	159	191	223	255
Start	0		Tr(0-31)	Tr(0-63)	Tr(0-95)	Tr(0-127)	Tr(0-159)	Tr(0-191)	Tr(0-223)	Tr(0-255)
	31	Tf(31-0)		Tr(31-63)	Tr(31-95)	Tr(31-127)	Tr(31-159)	Tr(31-191)	Tr(31-223)	Tr(31-255)
	63	Tf(63-0)	Tf(63-31)		Tr(63-95)	Tr(63-127)	Tr(63-159)	Tr(63-191)	Tr(63-223)	Tr(63-255)
	95	Tf(95-0)	Tf(95-31)	Tf(95-63)		Tr(95-127)	Tr(95-159)	Tr(95-191)	Tr(95-223)	Tr(95-255)
	127	Tf(127-0)	Tf(127-31)	Tf(127-63)	Tf(127-95)		Tr(127-159)	Tr(127-191)	Tr(127-223)	Tr(127-255)
	159	Tf(159-0)	Tf(159-31)	Tf(159-63)	Tf(159-95)	Tf(159-127)		Tr(159-191)	Tr(159-223)	Tr(159-255)
	191	Tf(191-0)	Tf(191-31)	Tf(191-63)	Tf(191-95)	Tf(191-127)	Tf(191-159)		Tr(191-223)	Tr(191-255)
	223	Tf(223-0)	Tf(223-31)	Tf(223-63)	Tf(223-95)	Tf(223-127)	Tf(223-159)	Tf(223-191)		Tr(223-255)
	255	Tf(255-0)	Tf(255-31)	Tf(255-63)	Tf(255-95)	Tf(255-127)	Tf(255-159)	Tf(255-191)	Tf(255-223)	
Toff										

T*(X-Y) : Response time from level of gray at X to level of gray at Y†

The definition of response time = $\sum [T*(X-Y)] / 72†$

Note (3) Definition of Luminance of White : Luminance of white at center point ⑤

Note (4) Definition of Color Chromaticity (CIE 1931)

Color coordinate of Red, Green, Blue & White at center point ⑤

Samsung Secret

3. Electrical Characteristics

3.1 TFT LCD Module

The connector for display data & timing signal should be connected.

$T_a = 25^{\circ}\text{C} \pm 2^{\circ}\text{C}$

Item	Symbol	Min.	Typ.	Max.	Unit	Note
Voltage of Power Supply	V_{DD}	10.8	12.0	13.2	V	(1)
Current of Power Supply	(a) Black	-	400	500	mA	(2),(3)
	(b) White	-	500	600	mA	
	(c) N-PTN	-	600	700	mA	
Vsync Frequency	f_V	48	60	66	Hz	
Hsync Frequency	f_H	44	48	53	kHz	
Main Frequency	f_{DCLK}	72	78	85	MHz	
Rush Current	I_{RUSH}	-	-	4	A	(4)

Note (1) The ripple voltage should be controlled under 10% of V_{DD} .

(2) $f_V=60\text{Hz}$, $f_{DCLK} = 78\text{MHz}$, $V_{DD} = 12.0\text{V}$, DC Current.

(3) Power dissipation check pattern (LCD panel only)

a) Black Pattern

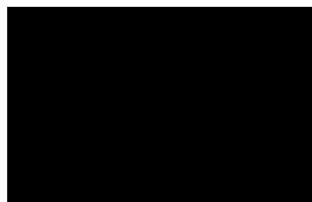

b) White Pattern



c) N-PTN



(4) Measurement Conditions

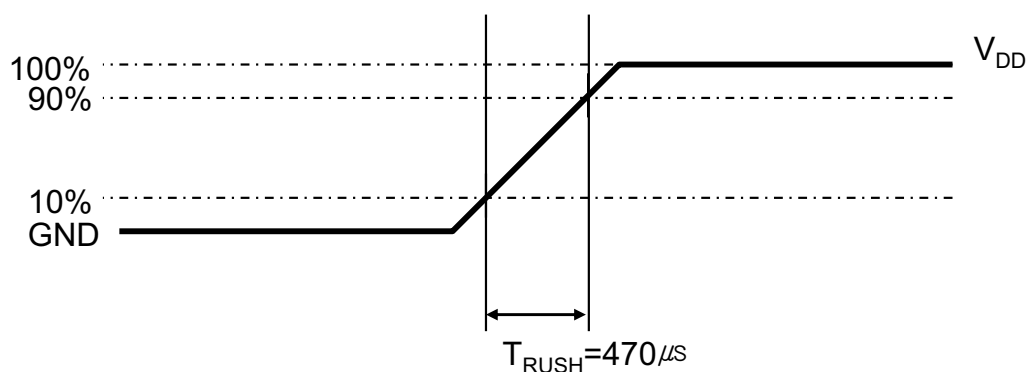

Rush Current I_{RUSH} can be measured when T_{RUSH} is $470 \mu\text{s}$.

4. Input Terminal Pin Assignment

Samsung Secret

4.1 Input Signal & Power

Connector :IS100-L300-C23

PIN No.	Description	PIN No.	Description
1	No Connection (Note1)	16	GND
2	No Connection (Note1)	17	RxIN3-
3	No Connection (Note1)	18	RxIN3+
4	GND	19	GND
5	RxIN0-	20	No Connection (Note1)
6	RxIN0+	21	LVDS OPTION (Note 2)
7	GND	22	No Connection (Note1)
8	RxIN1-	23	GND
9	RxIN1+	24	GND
10	GND	25	No Connection (Note 1)
11	RxIN2-	26	Vin
12	RxIN2+	27	Vin
13	GND	28	Vin
14	RxCLK-	29	Vin
15	RxCLK+	30	Vin

Note1) No Connection: **This PINS are only used ONLY for SAMSUNG.**

Note2) LVDS OPTION : If this PIN is HIGH (3.3 V) → Normal LVDS format
LOW (GND) → JEIDA LVDS format

SEQUENCE : On = $V_{DD}(T1) \geq \text{LVDS Option} \geq \text{Interface Signal}(T2)$
OFF = $\text{Interface Signal}(T3) \geq \text{LVDS Option} \geq V_{DD}$

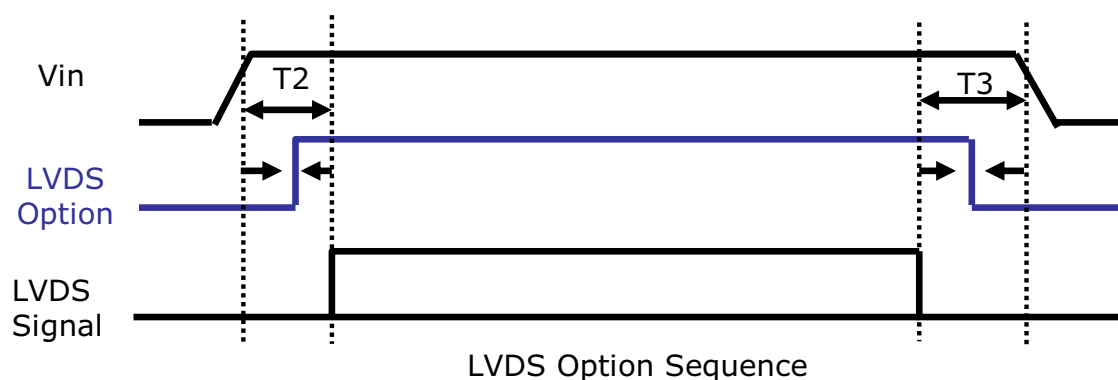

4.2 LVDS Interface

- LVDS Receiver : T-con (merged)
- Data Format

Samsung Secret

	LVDS pin	JEIDA -DATA	VESA -DATA
TxOUT/RxIN0	TxIN/RxOUT0	R2	R0
	TxIN/RxOUT1	R3	R1
	TxIN/RxOUT2	R4	R2
	TxIN/RxOUT3	R5	R3
	TxIN/RxOUT4	R6	R4
	TxIN/RxOUT6	R7	R5
	TxIN/RxOUT7	G2	G0
TxOUT/RxIN1	TxIN/RxOUT8	G3	G1
	TxIN/RxOUT9	G4	G2
	TxIN/RxOUT12	G5	G3
	TxIN/RxOUT13	G6	G4
	TxIN/RxOUT14	G7	G5
	TxIN/RxOUT15	B2	B0
	TxIN/RxOUT18	B3	B1
TxOUT/RxIN2	TxIN/RxOUT19	B4	B2
	TxIN/RxOUT20	B5	B3
	TxIN/RxOUT21	B6	B4
	TxIN/RxOUT22	B7	B5
	TxIN/RxOUT24	HSYNC	HSYNC
	TxIN/RxOUT25	VSYNC	VSYNC
	TxIN/RxOUT26	DEN	DEN
TxOUT/RxIN3	TxIN/RxOUT27	R0	R6
	TxIN/RxOUT5	R1	R7
	TxIN/RxOUT10	G0	G6
	TxIN/RxOUT11	G1	G7
	TxIN/RxOUT16	B0	B6
	TxIN/RxOUT17	B1	B7
	TxIN/RxOUT23	RESERVED	RESERVED

Samsung Secret

4.3 Input Signals, Basic Display Colors and Gray Scale of Each Color

COLOR	DISPLAY (8bit)	DATA SIGNAL																					GRAY SCALE LEVEL			
		RED							GREEN							BLUE										
		R0	R1	R2	R3	R4	R5	R6	R7	G0	G1	G2	G3	G4	G5	G6	G7	B0	B1	B2	B3	B4		B5	B6	B7
BASIC COLOR	BLACK	0	0	0	0	0	0	0	0	0	0	0	0	0	0	0	0	0	0	0	0	0	0	0	-	
	BLUE	0	0	0	0	0	0	0	0	0	0	0	0	0	0	0	0	1	1	1	1	1	1	1	1	-
	GREEN	0	0	0	0	0	0	0	0	1	1	1	1	1	1	1	1	0	0	0	0	0	0	0	0	-
	CYAN	0	0	0	0	0	0	0	0	1	1	1	1	1	1	1	1	1	1	1	1	1	1	1	1	-
	RED	1	1	1	1	1	1	1	1	0	0	0	0	0	0	0	0	0	0	0	0	0	0	0	0	-
	MAGENTA	1	1	1	1	1	1	1	1	0	0	0	0	0	0	0	0	1	1	1	1	1	1	1	1	-
	YELLOW	1	1	1	1	1	1	1	1	1	1	1	1	1	1	1	1	0	0	0	0	0	0	0	0	-
	WHITE	1	1	1	1	1	1	1	1	1	1	1	1	1	1	1	1	1	1	1	1	1	1	1	1	-
GRAY SCALE OF RED	BLACK	0	0	0	0	0	0	0	0	0	0	0	0	0	0	0	0	0	0	0	0	0	0	0	R0	
	DARK ↑	1	0	0	0	0	0	0	0	0	0	0	0	0	0	0	0	0	0	0	0	0	0	0	R1	
		0	1	0	0	0	0	0	0	0	0	0	0	0	0	0	0	0	0	0	0	0	0	0	R2	
		: : : : : :	: : : : : :	: : : : : :	: : : : : :	: : : : : :	: : : : : :	: : : : : :	: : : : : :	: : : : : :	: : : : : :	: : : : : :	: : : : : :	: : : : : :	: : : : : :	: : : : : :	: : : : : :	: : : : : :	: : : : : :	: : : : : :	: : : : : :	: : : : : :	: : : : : :	: : : : : :	R3~R252	
	LIGHT ↓	1	0	1	1	1	1	1	1	0	0	0	0	0	0	0	0	0	0	0	0	0	0	0	R253	
		0	1	1	1	1	1	1	1	0	0	0	0	0	0	0	0	0	0	0	0	0	0	0	R254	
	RED	1	1	1	1	1	1	1	1	0	0	0	0	0	0	0	0	0	0	0	0	0	0	0	R255	
GRAY SCALE OF GREEN	BLACK	0	0	0	0	0	0	0	0	0	0	0	0	0	0	0	0	0	0	0	0	0	0	0	G0	
	DARK ↑	0	0	0	0	0	0	0	0	1	0	0	0	0	0	0	0	0	0	0	0	0	0	0	G1	
		0	0	0	0	0	0	0	0	0	1	0	0	0	0	0	0	0	0	0	0	0	0	0	G2	
		: : : : : :	: : : : : :	: : : : : :	: : : : : :	: : : : : :	: : : : : :	: : : : : :	: : : : : :	: : : : : :	: : : : : :	: : : : : :	: : : : : :	: : : : : :	: : : : : :	: : : : : :	: : : : : :	: : : : : :	: : : : : :	: : : : : :	: : : : : :	: : : : : :	: : : : : :	: : : : : :	G3~G252	
	LIGHT ↓	0	0	0	0	0	0	0	0	1	0	1	1	1	1	1	1	0	0	0	0	0	0	0	G253	
		0	0	0	0	0	0	0	0	0	1	1	1	1	1	1	1	0	0	0	0	0	0	0	G254	
	GREEN	0	0	0	0	0	0	0	0	1	1	1	1	1	1	1	1	0	0	0	0	0	0	0	G255	
GRAY SCALE OF BLUE	BLACK	0	0	0	0	0	0	0	0	0	0	0	0	0	0	0	0	0	0	0	0	0	0	0	B0	
	DARK ↑	0	0	0	0	0	0	0	0	0	0	0	0	0	0	0	0	1	0	0	0	0	0	0	B1	
		0	0	0	0	0	0	0	0	0	0	0	0	0	0	0	0	0	1	0	0	0	0	0	B2	
		: : : : : :	: : : : : :	: : : : : :	: : : : : :	: : : : : :	: : : : : :	: : : : : :	: : : : : :	: : : : : :	: : : : : :	: : : : : :	: : : : : :	: : : : : :	: : : : : :	: : : : : :	: : : : : :	: : : : : :	: : : : : :	: : : : : :	: : : : : :	: : : : : :	: : : : : :	: : : : : :	B3~B252	
	LIGHT ↓	0	0	0	0	0	0	0	0	0	0	0	0	0	0	0	0	1	0	1	1	1	1	1	B253	
		0	0	0	0	0	0	0	0	0	0	0	0	0	0	0	0	0	1	1	1	1	1	1	B254	
	BLUE	0	0	0	0	0	0	0	0	0	0	0	0	0	0	0	0	1	1	1	1	1	1	1	B255	

Note) Definition of Gray :

Rn : Red Gray, Gn : Green Gray, Bn : Blue Gray (n = Gray level)

Input Signal : 0 = Low level voltage, 1 = High level voltage

5. Interface Timing

5.1 Timing Parameters (DE mode)

SIGNAL	ITEM	SYMBOL	MIN.	TYP.	MAX.	Unit	NOTE
Clock	Frequency	$1/T_C$	72	78	85	MHz	-
Hsync		F_H	44	48	53	KHz	-
Vsync		F_V	50	60	66	Hz	-
Vertical Display Term	Active Display Period	T_{VD}	-	768	-	Lines	-
	Vertical Total	T_V	780	802	1200	Lines	-
Horizontal Display Term	Active Display Period	T_{HD}	-	1366	-	Clocks	-
	Horizontal Total	T_H	1460	1624	2000	clocks	-

Note) For DE only mode,

Product doesn't have to receive the signal of H-sync and V-sync from input device.

(1) Test Point : TTL control signal and CLK at input terminal of LVDS Tx of the system

(2) Internal VDD = 3.3V

(3) Spread spectrum

- Modulation rate (max) : $\pm 1.5\%$

- Modulation Frequency : under 100KHz

Samsung Secret

5. 2 LVDS Input Data Characteristics

ITEM	SYMBOL	Min.	Typ.	Max.	UNIT	NOTE
Input common mode voltage	V_{CM}	0.2	-	2.0	V	
Differential Input Voltage	$ V_{ID} $	100	-	-	mV	
Input Data Position	$F_{IN}=85\text{MHz}$	t_{RSRM}	-	-	400	ps
		t_{RSLM}	-400	-	-	ps

Note) The Spread Spectrum should be 0% when the skew is measured.

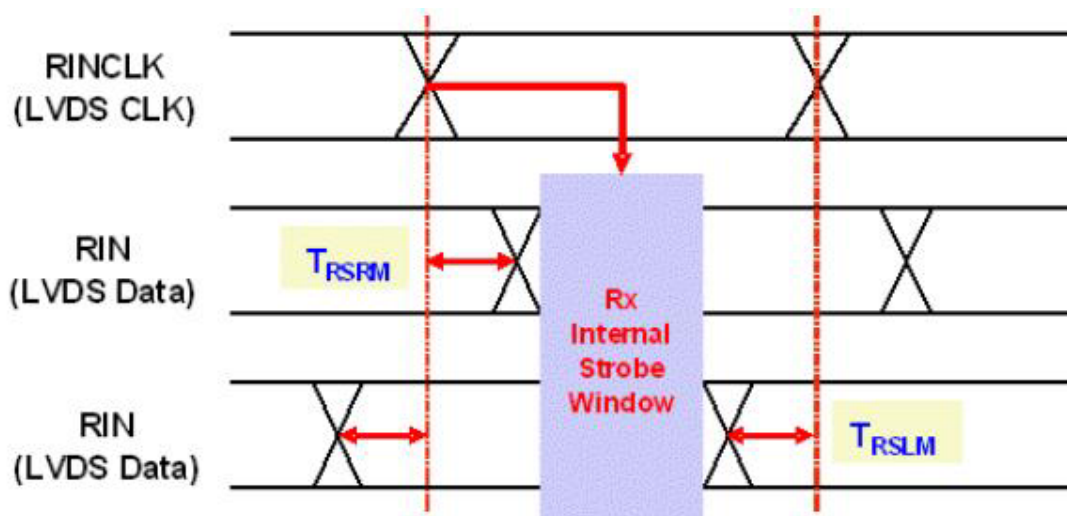
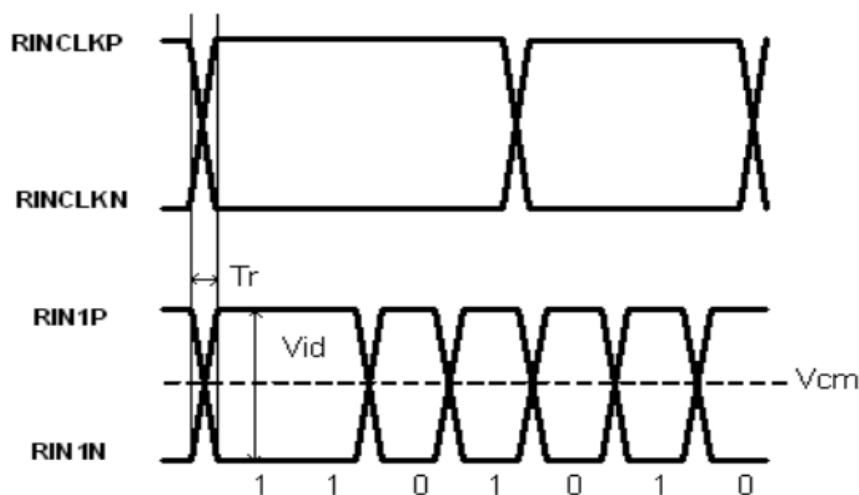

Samsung Secret

5.3 Timing diagrams of interface signal (DE mode)

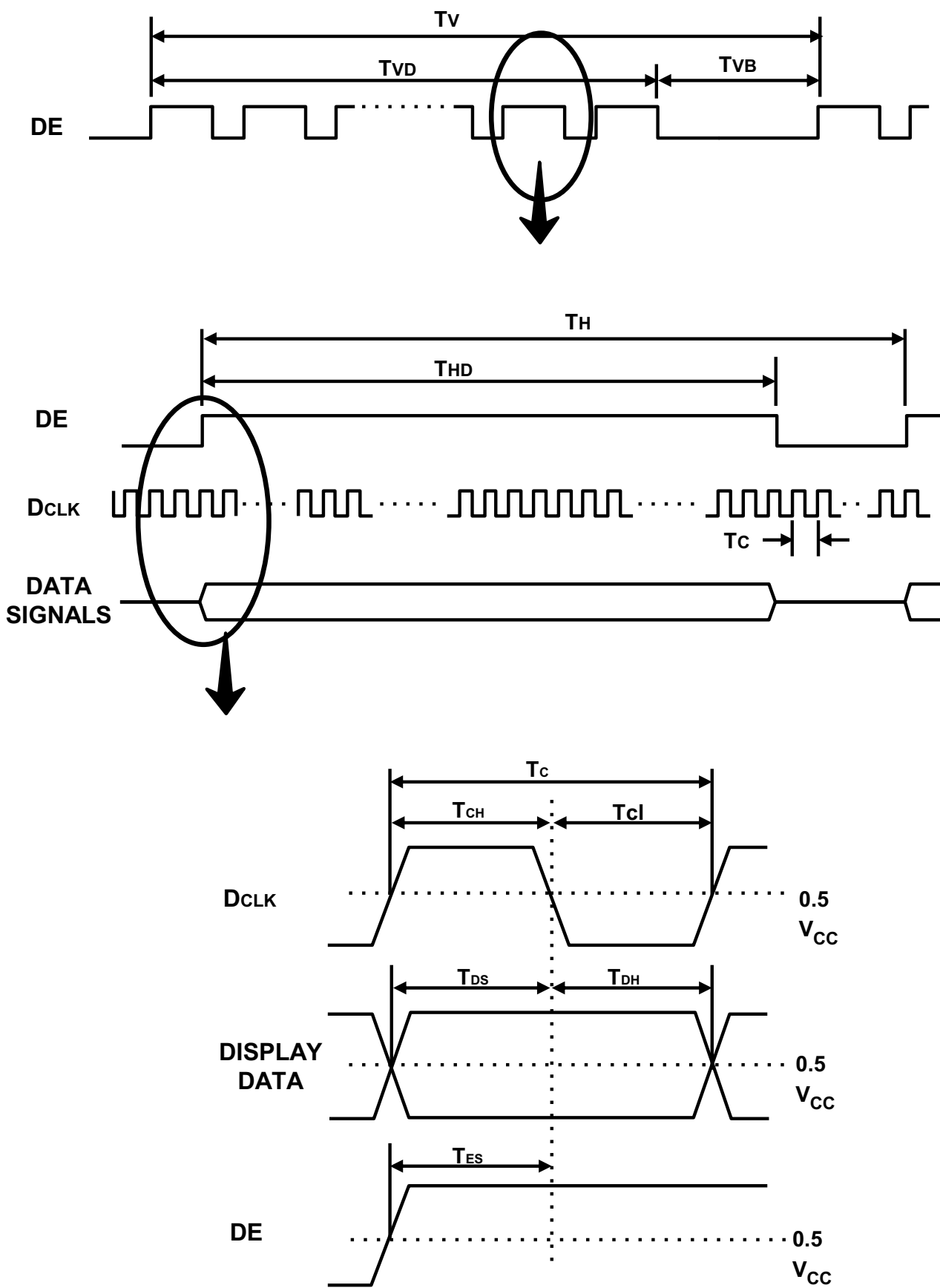

5.4 Power ON/OFF Sequence

Samsung Secret

To prevent a latch-up or DC operation of the LCD Module, the power on/off sequence should be accorded with the settings described in the diagram below.

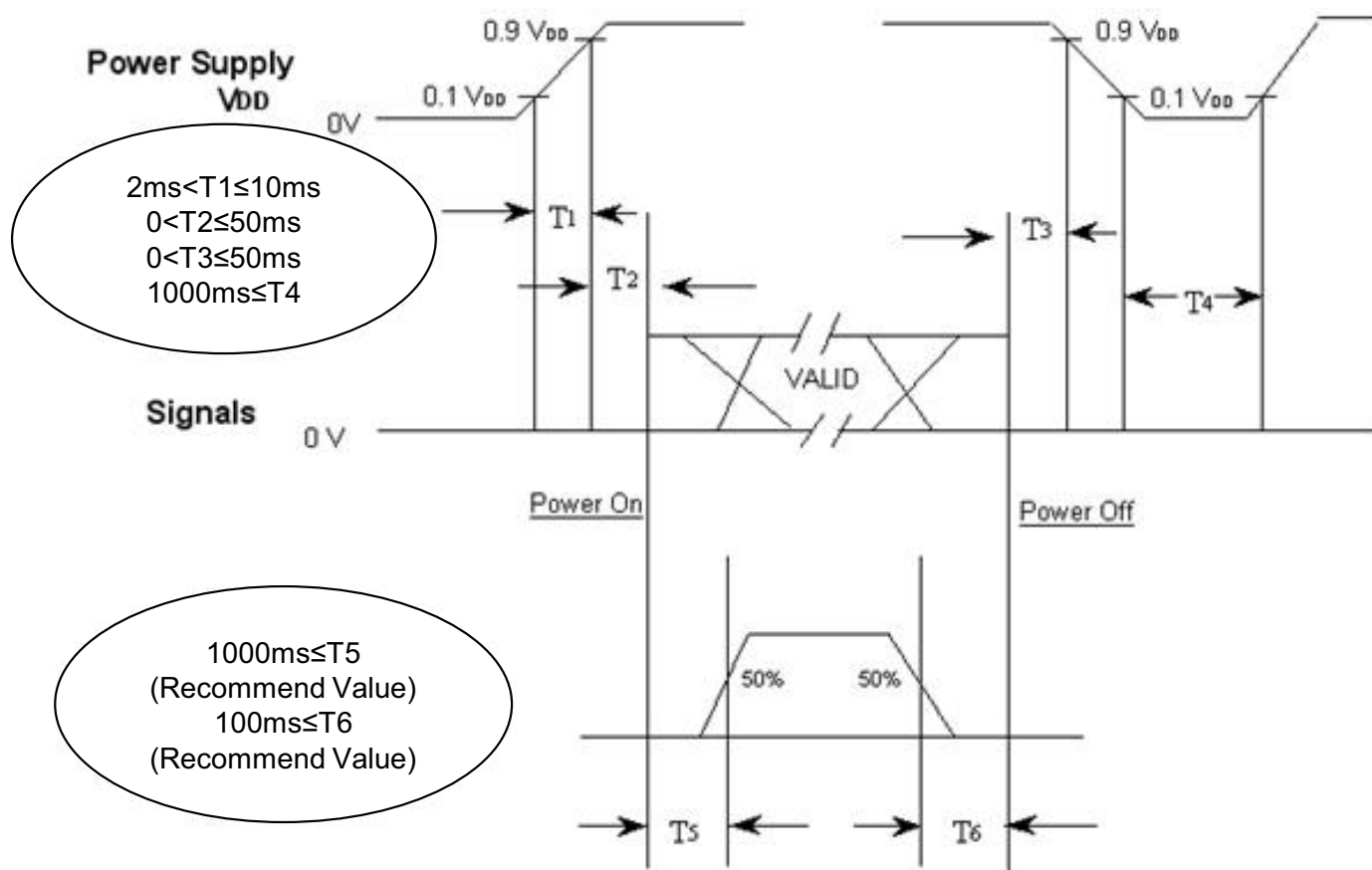

- T₁ : V_{DD} rising time from 10% to 90%
- T₂ : The time from V_{DD} to valid data at power ON.
- T₃ : The time from valid data off to V_{DD} off at power Off.
- T₄ : V_{DD} off time for Windows restart
- T₅ : The time from valid data to B/L enable at power ON.
- T₆ : The time from valid data off to B/L disable at power Off.

- The condition of supply voltage to enter in the module from the external system should have the same condition as the definition of VDD.
- Apply the voltage for the lamp within the range which the LCD operates. When the back light is turned on before the LCD is operated or when the LCD is turned off before the back light is turned off, the display may show the abnormal screen momentarily.
- While the VDD is off level, please keep the level of input signals low or keep a high impedance condition.
- The figure of T₄ should be measured after the module has been fully discharged between the periods when the power is on and off.
- The interface signal must not keep the high impedance condition when the power is on.
- Interface signal should not be kept at high impedance when the power is on.
- In Case T₅ is less than 1000msec and T₆ is less than 100msec, Garbage Display can be seen. (It is not related to electrical function issue, Just for recommendation to prevent Garbage Display)

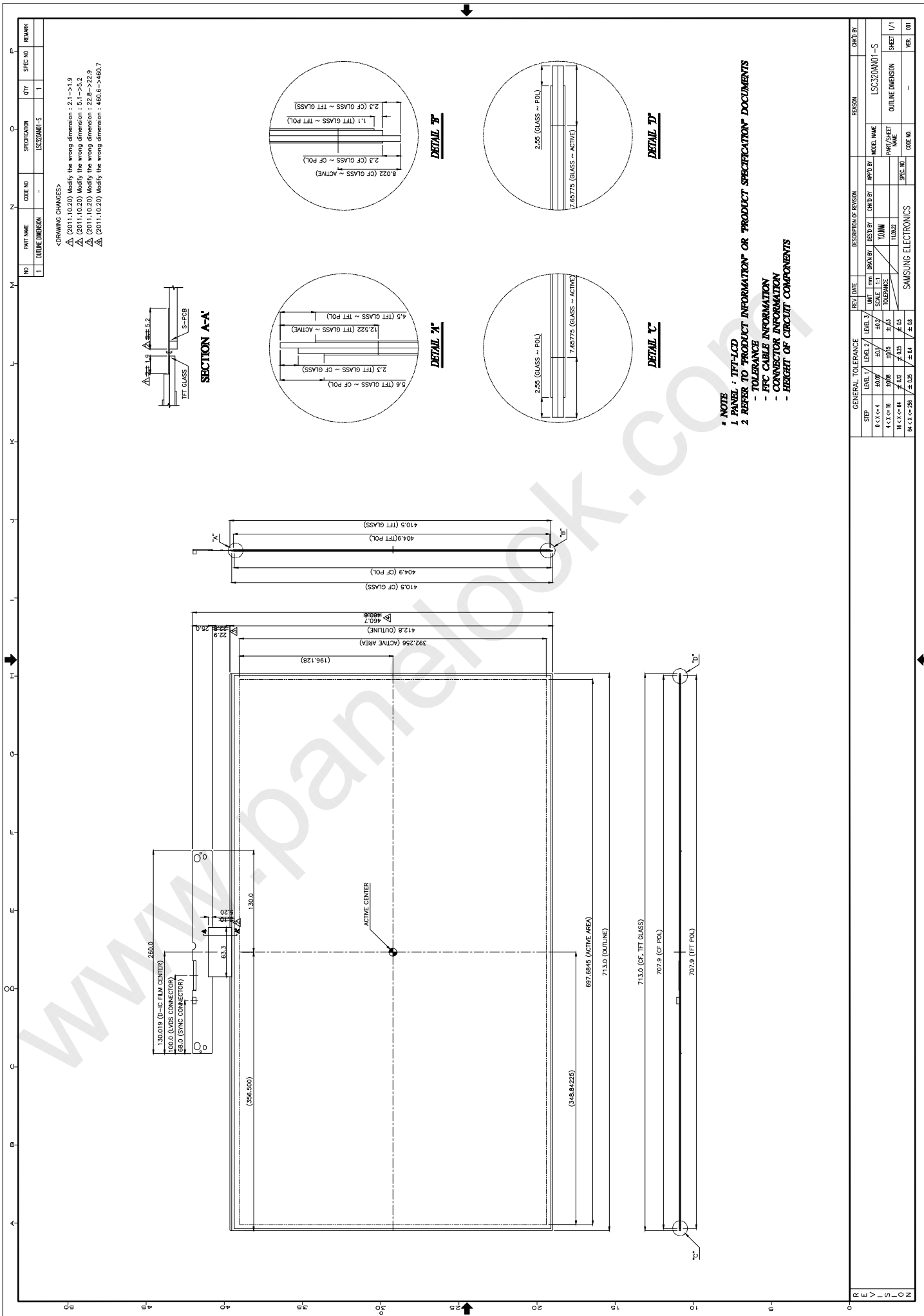

Samsung Secret

7. PACKING

7.1 The order for products to be stacked on the pallet

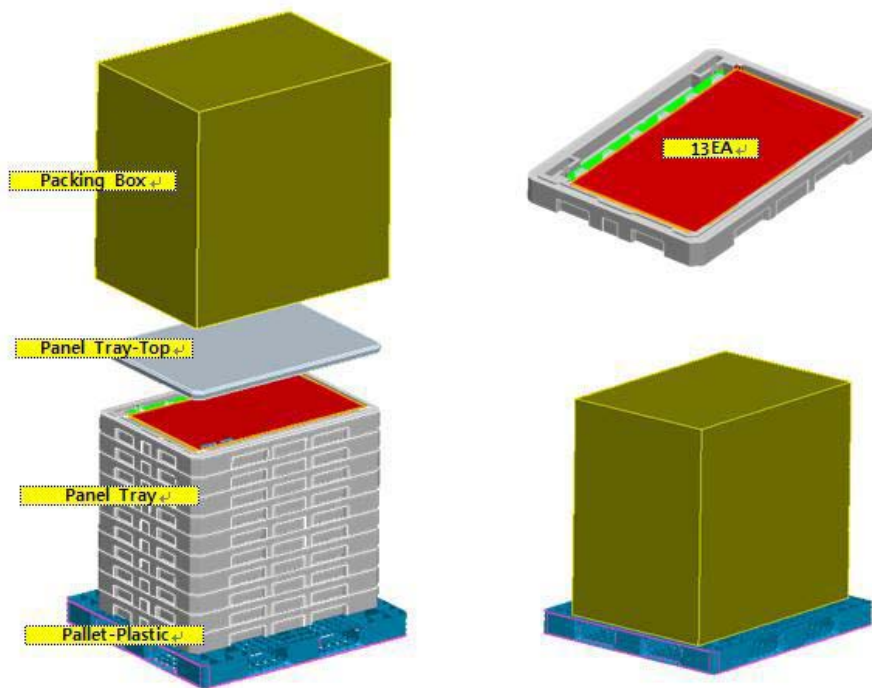

7.2 Packing Specification

Item	Specification	Remark
Total Pallet Size	W×V×Height [mm]	1270 X 1150 X 1150
Tray	13 [Panel/Tray]	- . Panel : 14.3kg (1.1 kg/Panel, 13ea/Tray)) - . Middle Sheet : 0.54kg (0.03 kg/ea, 18ea/Tray) - . Panel Tray : 1.2kg (EPS)
Pallet	20 [Tray/Pallet]	- . Pallet 18kg (High Density Polyethylene) - . 20ea(10tray x 2 array)+ 1ea(Top tray)
Total Weight	348.6 [kg]	- . Packing Box : 3kg (Paper)

Samsung Secret

8. MARKING & OTHERS

A nameplate bearing followed by is affixed to a shipped product at the specified location on each product.

(1) Cell Label

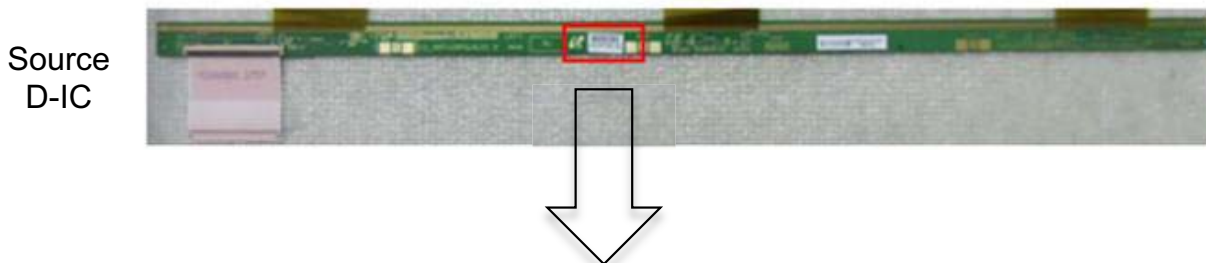

Lot number : X X X X XXX XX X

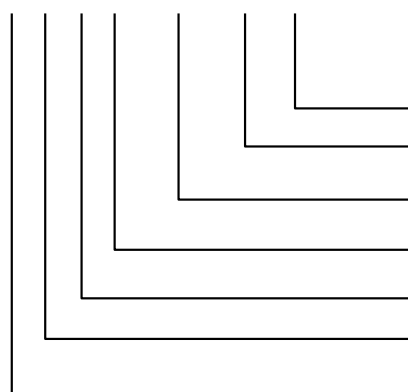

Cell Position No. (In the Glass)
Glass No. (In the one Lot)
Lot No. (Glass)
Month
Year (Note1)
Product code
Line

Samsung Secret

(2) Box Label



9. General Precautions

9.1 Handling

- (a) When the panel kit and BLU kit are assembled, the panel kit and BLU kit should be attached to the set system firmly by combining each mounted holes. Be careful not to give the mechanical stress.
- (b) Be careful not to give any extra mechanical stress to the panel when designing the set, and BLU kit.
- (c) Be cautious not to give any strong mechanical shock and / or any forces to the panel kit. Applying the any forces to the panel may cause the abnormal operation or the damage to the panel kit and the back light unit kit.
- (d) Refrain from applying any forces to the source PBA and the drive IC in the process of the handling or installing to the set. If any forces are applied to the products, it may cause a damage or a malfunction in the panel kit.
- (e) Refrain from applying any forces which cause a constant shock to the back side of panel kit, the set design and BLU kit. If any forces are applied to the products, it may cause an abnormal display, a functional failure and etc.
- (f) Note that polarizer could be damaged easily.
Do not press or scratch the bare surface with the material which is harder than a HB pencil lead.
- (g) Wipe off water droplets or oil immediately. If you leave the droplets for a long time on the product, a staining or the discoloration may occur.
- (h) If the surface of the polarizer is dirty, clean it using the absorbent cotton or the soft cloth.
- (i) Desirable cleaners are water or IPA(Isopropyl Alcohol).
Do not use Ketone type materials(ex. Acetone), Ethyl alcohol, Toluene, Ethyl acid or Methyl chloride. These might cause the permanent damage to the polarizer due to chemical reaction.
- (j) If the liquid crystal material leaks from the panel, this should be kept away from the eyes or mouth. If this contacts to hands, legs ,or clothes, you must washed it away with soap thoroughly and see a doctor for the medical examination.
- (k) Protect the panel kit and BLU Kit out of the static electricity. Otherwise the circuit IC could be damaged.

- Reference : Process control standard of SEC

Samsung Secret

No.	Item	Control standard
1	Ionizer	All Equipment should be controlled under 150V.(Typ. 100V)
2	Carrying Roller	Carrying Roller should be controlled under 200V.
3	Equipment Ground Resistance	All Equipment Ground Should be less than 1ohm.

(l) Remove the stains with finger-stalls wearing soft gloves in order to keep the display clean in the process of the incoming inspection and the assembly process.

(m) Do not pull or fold the source drive IC which connects to the source PBA and the panel or the gate drive IC.

(n) Do not pull, fold or bend the source drive IC and the gate drive IC in any processes. If not, the source drive IC could be bent one time in the process of assembling the panel Kit and the BLU Kit.

(o) Do not adjust the variable resistor located on the panel kit and BLU kit except when adjusting the flicker.

(p) Do not touch the pins of the interface connector directly with bare hands.

(q) Be cautious not to be peeled off the protection film.

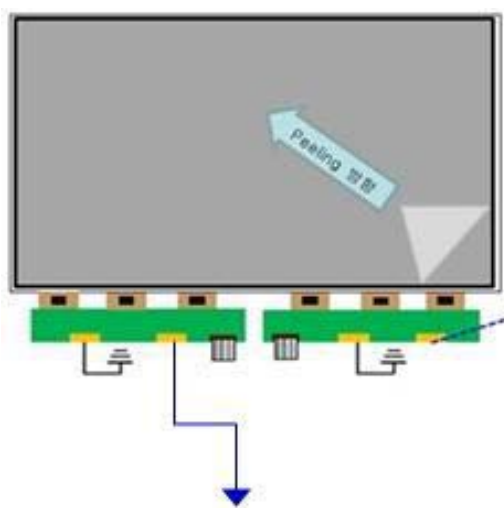

Fig. GND SR-Open Pattern – Be sure to be contacted to the ground while peeling of the protection film

- Make sure to peel off slowly
(It is recommended to peel it off at the speed of more than 8sec. constantly.)

-The peeling direction is shown at the left fig.

-Instruct the ground worker to work with the adequate methods such as the antistatic wrist band.

- Make sure to be grounded the source PBA while peeling of the protection film.

-Ionized air should be blown over during the peeling

- The protection film should not be contacted to the source drive IC.

- If the adhesive stains remain on the polarizer after the protection film is peeled off, please remove stains with isopropyl-alcohol liquid.

Samsung Secret

9.2 Storage

ITEM	Unit	Min.	Max.				
Storage Temperature	(°C)	5	40				
Storage Humidity	(%rH)	35	75				
Storage life	6 months						
Storage Condition	(1) The storage room should provide good ventilation and temperature control. (2) Products should not be placed on the floor, but on the Pallet away from a wall. (3) Prevent products from direct sunlight, moisture nor water; Be cautious of a build up of condensation. (4) Avoid other hazardous environment while storing goods. (5) If products delivered or kept in conditions of the recommended temperature or humidity, we recommend you leave them at a circumstances which is shown in the following table.						
	After	1 month	2 month	3 month	4month	5 month	6month
	Baking	No backing		50°C 10% 24Hr	50°C 10% 48Hr		

9.3 Operation

- (a) Do not connect, disconnect the module in the "Power On" condition.
- (b) Power supply should always be turned on/off by the item 5.5 "Power on/off sequence"
- (c) Module has high frequency circuits. Sufficient suppression to the electromagnetic interference shall be done by system manufacturers. Grounding and shielding methods may be important to minimize the interference.
- (d) The cable between the back-light connector and its inverter power supply shall be a minimized length and be connected directly. The longer cable between the back-light and the inverter/converter may cause lower luminance of CCFL/LED and may require higher startup voltage(Vs).

9.4 Operation Condition Guide

(a) The LCD product should be operated under normal conditions.

Normal condition is defined as below;

- Temperature : $20 \pm 15^{\circ}\text{C}$
- Humidity : $55 \pm 20\%$
- Display pattern : continually changing pattern (Not stationary)

(b) If the product will be used in extreme conditions such as high temperature, humidity, display patterns or operation time etc., It is strongly recommended to contact SEC for Application engineering advice. Otherwise, its reliability and function may not be guaranteed. Extreme conditions are commonly found at Airports, Transit Stations, Banks, Stock market, and Controlling systems.

9.5 Others

(a) The ultra-violet ray filter is necessary for the outdoor operation.

(b) Avoid the condensation of water which may result in the improper operation of product or the disconnection of electrode.

(c) Do not exceed the limit on the absolute maximum rating. (For example, the supply voltage variation, the input voltage variation, the variation in content of parts and environmental temperature, and so on) If not, the module may be damaged.

(d) If the module keeps displaying the same pattern for a long period of time, the image may be remained to the screen.
To avoid the image sticking, it is recommended to use a screen saver.

(e) This module has its circuitry of PCB's on the rear side and should be handled carefully in order for a force not to be applied.

(f) Please contact the SEC in advance when the same pattern is displayed for a long time.