

DATE: 11.Dec.2012

SAMSUNG TFT-LCD

MODEL: LSC320AN03-W

The Information described in this specification is for the first draft and can be changed without prior notice

Samsung Display Co., LTD

MODEL	LSC320AN03	Doc. No		Page	1 / 23
-------	------------	---------	--	------	--------

General Description

Description

This model uses a liquid crystal display (LCD) of amorphous silicon TFT as switching components. This model is composed of a TFT LCD panel, a driver circuit, and an ass'y KIT of source PBA. This 46.0" model has a resolution of a 1366 x 768 and can display up to 16.7 million colors with the wide viewing angle of 89° or a higher degree in all directions. This panel is designed to support applications by providing an excellent performance function of the flat panel display such as home-alone multimedia TFT-LCD TV and a high definition TV.

General Information

Features

- RoHS compliance (Pb-free)
- High contrast ratio & aperture ratio with the wide color gamut
- SPVA(Super patterned vertical align) mode
- Wide viewing angle ($\pm 178^\circ$)
- High speed response
- HD resolution (16:9)
- Low power consumption
- DE (Data enable) mode
- The interface (2pixel/clock) of 1ch LVDS (Low voltage differential signaling)

Items	Specification	Unit	Note
Active Display Area	697.6845 (H) x 392.256 (V)	mm	
Switching Components	a-Si TFT Active matrix		
Glass Size	TFT : 713.0 (H) x 410.5 (V) CF : 713.0 (H) x 408.2 (V)	mm	$\pm 0.4\text{mm}$
Panel Size	713.0 (H) x 410.5 (V)	mm	$\pm 0.4\text{mm}$
	1.80(D)	mm	$\pm 0.1\text{mm}$
Weight	1200 (max 1320)	g	$\pm 10\%$
Display Colors	16.7M (True Display) 1.07B (Dithered 10bit)	color	
Number of Pixels	1,366 × 768	pixel	16 : 9
Pixel Arrangement	RGB Vertical Stripe		
Display Mode	Normally Black		
Surface Treatment	AG-POL(Anti-Glare),		
Haze	Haze 2.3%		$\pm 2.1\%$
Hardness	Hard coating 2H		

1. Absolute Maximum Ratings

If the figures on measuring instruments exceed maximum ratings, it can cause the malfunction or the unrecoverable damage on the device.

Item	Symbol	Min.	Max.	Unit	Note
Power supply voltage	V_{DD}	10.8	13.2	V	(1)
Temperature for storage	T_{STG}	-20	65	°C	(2),(4)
Temperature of glass surface	T_{OPR2}	0	65	°C	(2)
Operating temperature	T_{OPR}	0	50	°C	(2),(5)
Humidity for storage	H_{STG}	5	95	%RH	(2),(4)
Operating humidity	H_{OPR}	20	95	%RG	(2),(5)
Endurance on static electricity			150	V	(3)

Note (1) The power supply voltage at $T_a = 25 \pm 2 \text{ }^\circ\text{C}$

(2) Temperature and the range of relative humidity are shown in the figure below.

- a. 95 % RH Max. ($T_a \leq 39 \text{ }^\circ\text{C}$)
- b. The relative humidity is 95% or less. ($T_a > 39 \text{ }^\circ\text{C}$)
- c. No condensation
- d. Operating condition with SET

(3) Keep the static electricity under 150V in Polarizer attaching process.

(4) Operating condition with source PCB

(5) Storage temperature condition including glass

(6) Condition without packing. (Unpacking condition)

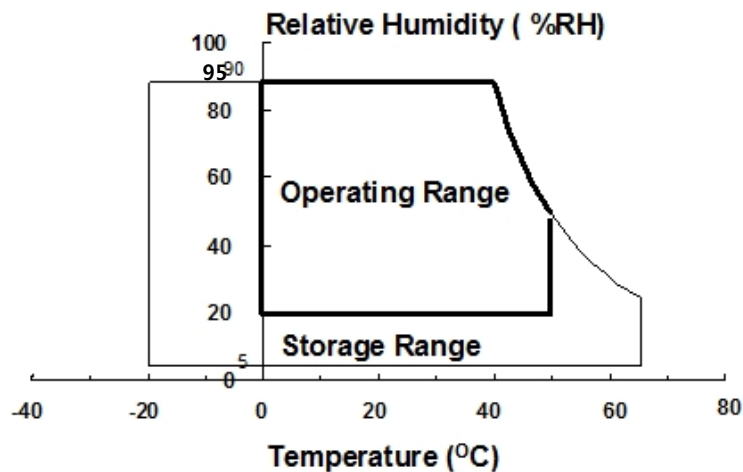

Fig. Range for temperature and relative humidity

2. Optical characteristics

The optical characteristics should be measured in the dark room or the space surrounded by the similar setting.

Measuring equipment : TOPCON RD-80S, TOPCON SR-3 ,ELDIM EZ-Contrast

(Ta = 25 ± 2°C, VDD=12.0V, fv=60Hz, f_{dclk}=148.5MHz, Light source: D65 Standard light)

Item	Symbol	Condition	Min.	Typ.	Max.	Unit	Light Source	Note	
Contrast ratio (At the center of screen)	C/R		4000	5000	-		Standard	(1) SR-3	
Response time	G-to-G	Tg		8	16	msec	Standard or VD BLU	(3) RD-80S	
Luminance of white (At the center of screen)	Y _L		250	300	-	cd/m ²	VD BLU	(4) SR-3	
Chromaticity (CIE 1931)	Red	Rx	Normal q _L ,R=0 q _U ,D=0 Viewing Angle	0.640	TYP. -0.03	TYP. +0.03	VD BLU	(5),(6) SR-3	
		Ry		0.330					
	Green	Gx		0.300					
		Gy		0.600					
	Blue	Bx		0.150					
		By		0.060					
	White	Wx		0.280					
		Wy		0.290					
sRGB Concordance	-		99		%	VD BLU	(5) SR-3		
Color gamut	-	-	72	-	%				
Color	-	-	10,000	-	K				
Viewing Angle	Hor.	q _L	C/R≥10	75	89	-	Degree	Standard or VD BLU	(6) SR-3 EZ-Contrast
		q _R		75	89	-			
	Ver.	q _U		75	89	-			
		q _D		75	89	-			
Brightness uniformity (9 Points)	B _{uni}		-	-	25	%	Standard	(2) SR-3	
Transmissivity	T		5.3	5.7	-	%	Standard	(7) D65/SR3	
Transmissivity Uniformity	T _{uni}		-	-	10	%	Standard	(8) D65/SR3	
Gamma Value	GMA	(@20G~200G)	2.0	2.2	2.4		Standard or VD BLU	(9) SR-3	
Gamma variation	Gdiff	(@20G~128G)	-0.14	-	0.14			(11) SR-3	
ACC Linearity	ACC_lin		-0.015	-	0.015		Standard or VD BLU	(12) SR-3	
5nit Uniformity	Buni_5nit		-30	-	30	%	Standard (38G/255G)	(10) SR-3	
White Color Coordinate Uniformity	Wx uni		-	-	0.005		Standard	(13) SR-3	
	Wy uni	0.008							

Notice

MODEL	LSC320AN03	Doc. No		Page	4 / 23
-------	------------	---------	--	------	--------

(a) Setup for test equipment

The measurement should be executed in a stable, windless, and dark room for 40min and 60min after operating the panel at the given temperature for stabilization of the standard light. (SDC uses the standard luminance of the D65 media).

This measurement should be measured at the center of screen.

The environment condition: $T_a = 25 \pm 2 \text{ } ^\circ\text{C}$

(b) D65 media has the general light source.

The temperature of color is 6847K. The coordinate of color is $W_x 0.313, W_y 0.329$

The luminance of this product is 7217cd/m^2 .

Photo detector	Field
SR-3	2°/1°
RD-80S	1°

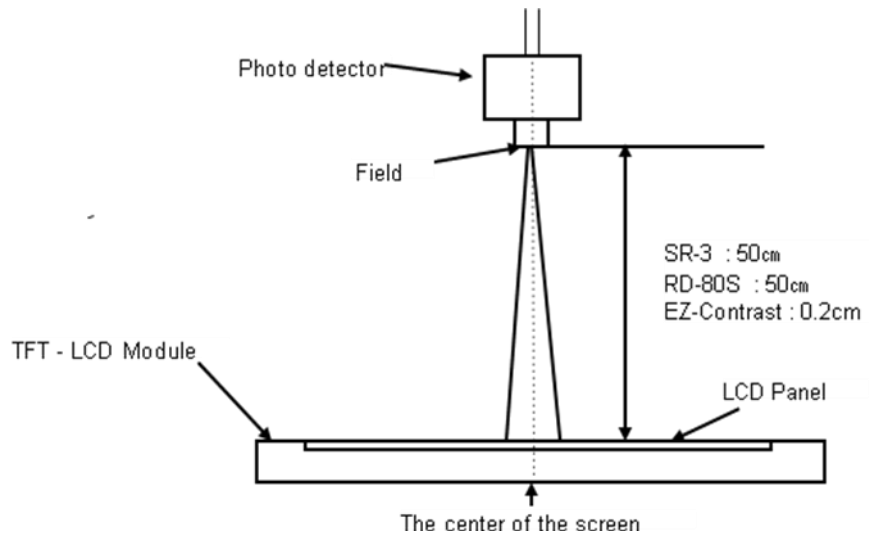

(c) The CIE positions D65 as the standard daylight illuminant:

[D65] is intended to represent average daylight and has a correlated color temperature of approximately 6500 K. CIE standard illuminant D65 should be used in all colorimetric calculations requiring representative daylight, unless there are specific reasons for using a different illuminant.

- Definition of the test point

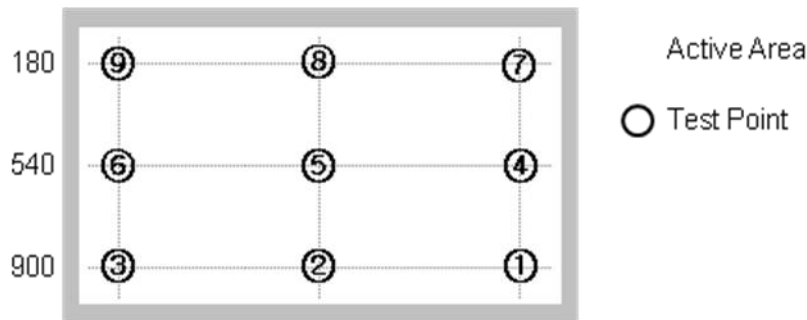

Note (1) Definition of contrast ratio (C/R)

: The ratio of gray max (G_{max}) & gray min (G_{min}) at the center point ⑤ of the panel
 The measurement goes in D65 Standard light source

$$C/R = \frac{G_{max}}{G_{min}}$$

G_{max} : The luminance with all white pixels

Gmin : The luminance with all black pixels

Note (2) Definition of the brightness uniformity of 9 points (Test pattern : The full white)
 The measurement shall be executed with the standard light source of D65 .

$$B_{uni} = 100 * \frac{(B_{max} - B_{min})}{B_{max}}$$

Bmax : The maximum brightness

Bmin : The minimum brightness

Note (3) Definition of the response time : Sum of Tr, Tf

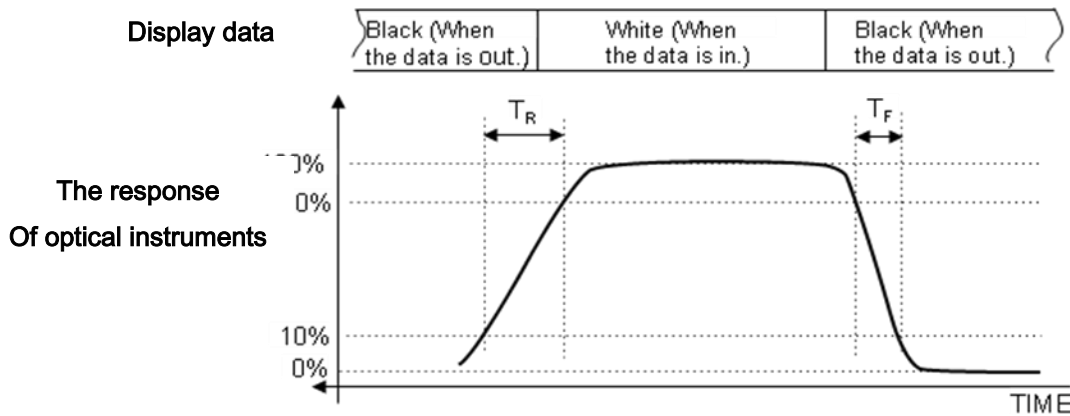

※ G-to-G : Average response time between whole gray scale to whole gray scale.

The response time is the value that was measured after it was operated in Samsung's standard BLU for one hour.(at room temperature)

Note (4) The definition of luminance of white: The luminance of white at the center point ⑤

The measurement shall be executed with the standard light source of D65.

Note (5) The definition of chromaticity (CIE 1931)

The color coordinate of red, green, blue and white at the center point ⑤

The measurement shall be executed with the standard light source of D65.

Note (6) Definition of viewing angle

: The range of viewing angle (C/R ≥ 10)

The measurement shall be executed with the standard light source of D65.

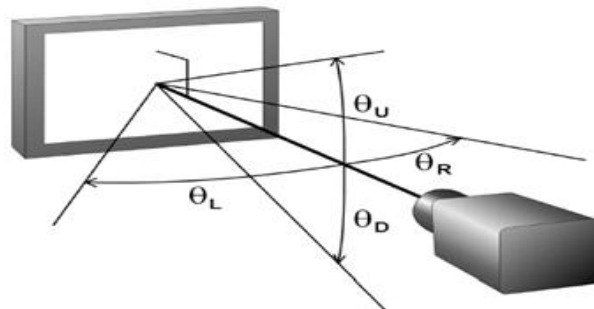

Note (7) Definition of transmissivity

The measurement shall be executed with the standard light source of D65.

Note (8) Definition of the Transmissivity uniformity of 9 points (Test pattern: The full white)

The measurement shall be executed with the standard light source of D65.

$$T_{uni} = 100 * \frac{(T_{max} - T_{min})}{T_{max}}$$

Tmax : The maximum Transmissivity

Tmin : The minimum Transmissivity

Note (9) Management Criteria of Gamma Value

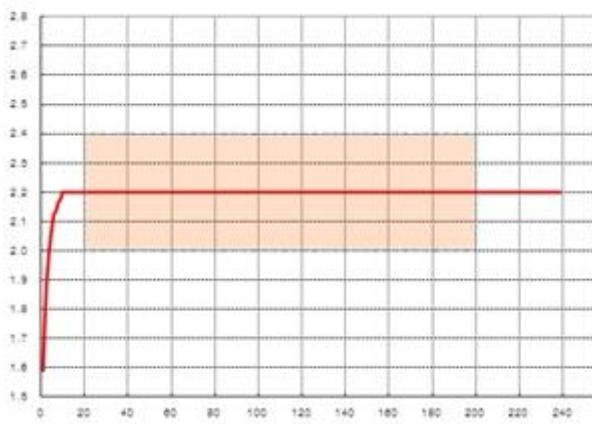

Gamma Value :

20 ~ 200Gray : 2.0 ~ 2.4 (Typ. 2.2)

Note (10) 5nit Low Gray Uniformity

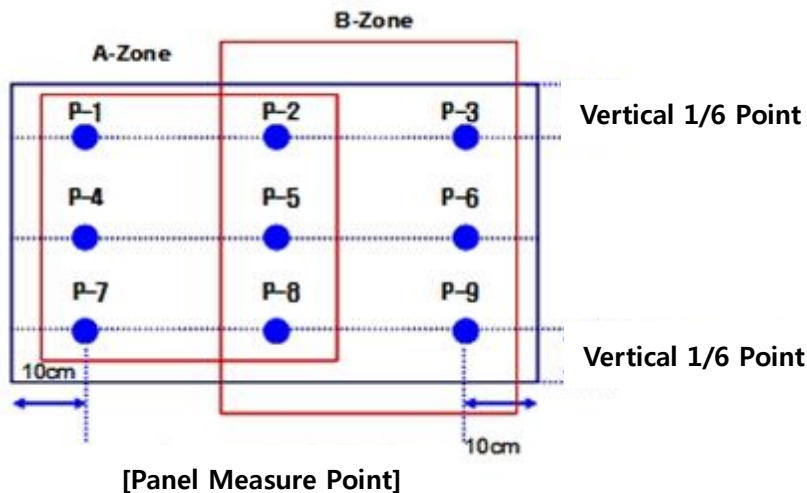

$$B_{uni_5nit} = 100 * \frac{(B_{max_5nit} - B_{min_5nit})}{B_{max_5nit}}$$

Bmax_5nit : The maximum brightness at 5nit Gray

Bmin_5nit : The minimum brightness at 5nit Gray

Note (11) Gamma Variation between Center and Left (or Right)

Gamma measured at 10cm point from the left & right side is more less than 0.1 than Gamma measured at Center

(Gamma measured at 10cm of the P-4 & P-6 is more less than 0.1 than Gamma measured at P-5)

Note (12) Management Criteria of ACC Linearity

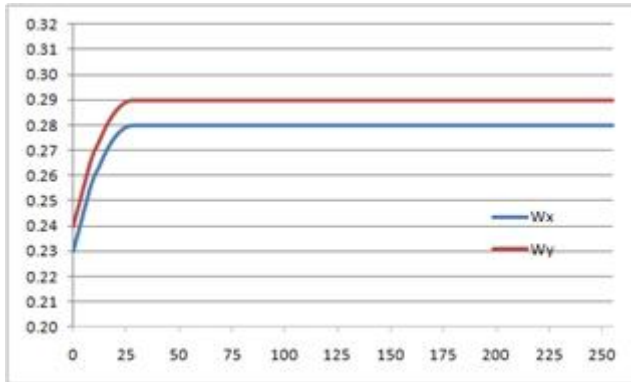

255Gray Wx/Wy value basis (a module unit basis)

a. Color coordinate differences are less than 15/1,000 at Any Point above 30Gray and 255Gray

b. When Wx/Wy coordinates reverse at 0Gray, it permits an once intersection under, 30Gray

Note (13) White Color Coordinate Uniformity of 9 points (Test pattern: The full white)

$$W_x, uni = W_x \text{ max} - W_x \text{ min}$$

Wx max : The maximum Wx

Wx min : The minimum Wx

$$W_y, uni = W_y \text{ max} - W_y \text{ min}$$

Wy max: The maximum Wy

Wy min: The minimum Wy

3. Electrical characteristics – Sony Model Attached Reference file

3.1 TFT LCD Module

The connector for the display data & timing signal should be connected.

Ta = 25°C ± 2 °C

Item	Symbol	Min.	Typ.	Max.	Unit	Note
Voltage of power supply	V _{DD}	10.8	12.0	13.2	V	(1)
Current of power supply	(a) Black	-	326	700	mA	(2),(3)
	(b) White	-	369	700	mA	
	(c) V_Stripe	-	595	1000	mA	
Vsync frequency	f _V	48	60	66	Hz	
Hsync frequency	f _H	44	48	53	kHz	
Main frequency	Fdclk	72	78	85	MHz	
Rush current	I _{RUSH}	-	-	2	A	(4)

Note (1) The ripple voltage should be controlled fewer than 10% of V_{DD} (Typ.) voltage.

(2) fV=60Hz, fDCLK =148.5MHz, V_{DD} = 12.0V, DC Current.

(3) Power dissipation check pattern (LCD Module only)

a) Black pattern



b) White pattern



c) V Stripe

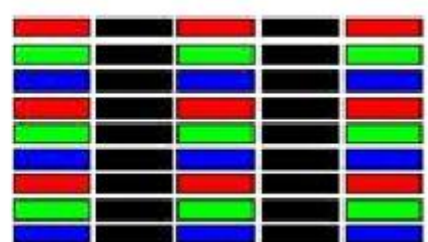

(4) Conditions for measurement

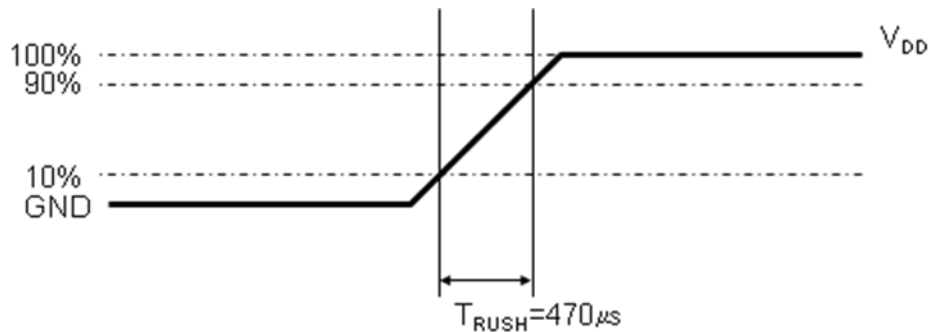

The rush current, I_{RUSH} can be measured during T_{RUSH} is 470us

4. Block diagram

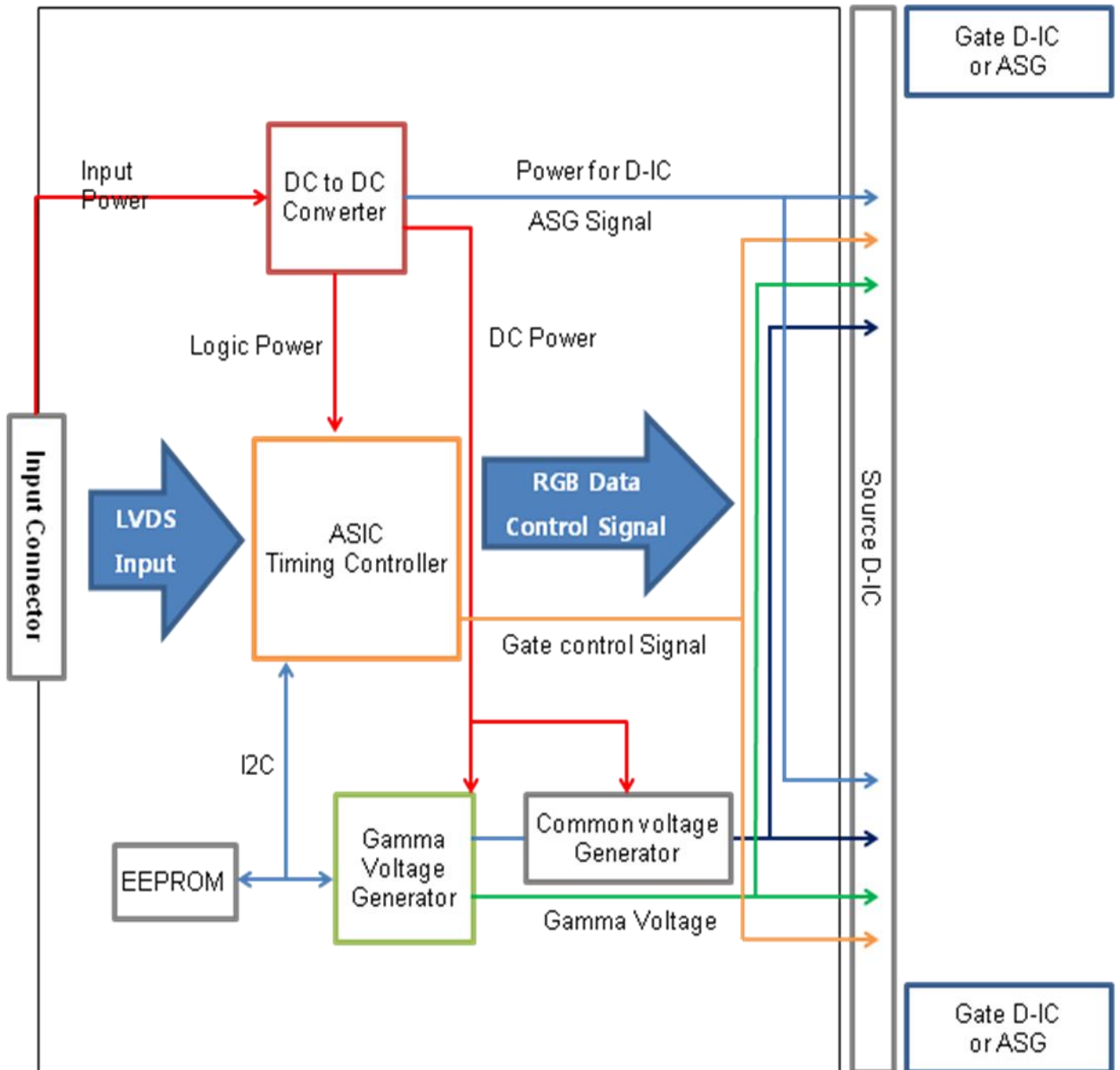

5. The Pin assignment in the input terminal

5.1. Input signal & power

connector : YOUNHO (30Pin,SMD-A)

No	Signal	REMARK
1	WPN	WPN
2	SCL	I2C interface
3	SDA	
4	GND	GND
5	LV0_N	LVDS
6	LV0_P	
7	GND	GND
8	LV1_N	negative LVDS differential data input (0)
9	LV1_P	positive LVDS differential data input (0)
10	GND	GND
11	LV2_N	negative LVDS differential data input (1)
12	LV2_P	positive LVDS differential data input (1)
13	GND	GND
14	LVCLK_N	negative LVDS differential data input (Clock)
15	LVCLK_P	positive LVDS differential data input (Clock)
16	GND	GND
17	LV3_N	negative LVDS differential data input (3)
18	LV3_P	positive LVDS differential data input (3)
19	GND	GND
20	AGING_ENI	AGING OPTION (Low: Active)
21	LVDS_SEL	LVDS OPTION (Low: JEIDA, High: VESA)
22	WPN	WPN
23	GND	GND
24	GND	
25	N.C	
26	VIN	Power Supply : +12V
27	VIN	
28	VIN	
29	VIN	
30	VIN	

Note (1) Pin number which starts from the left side.

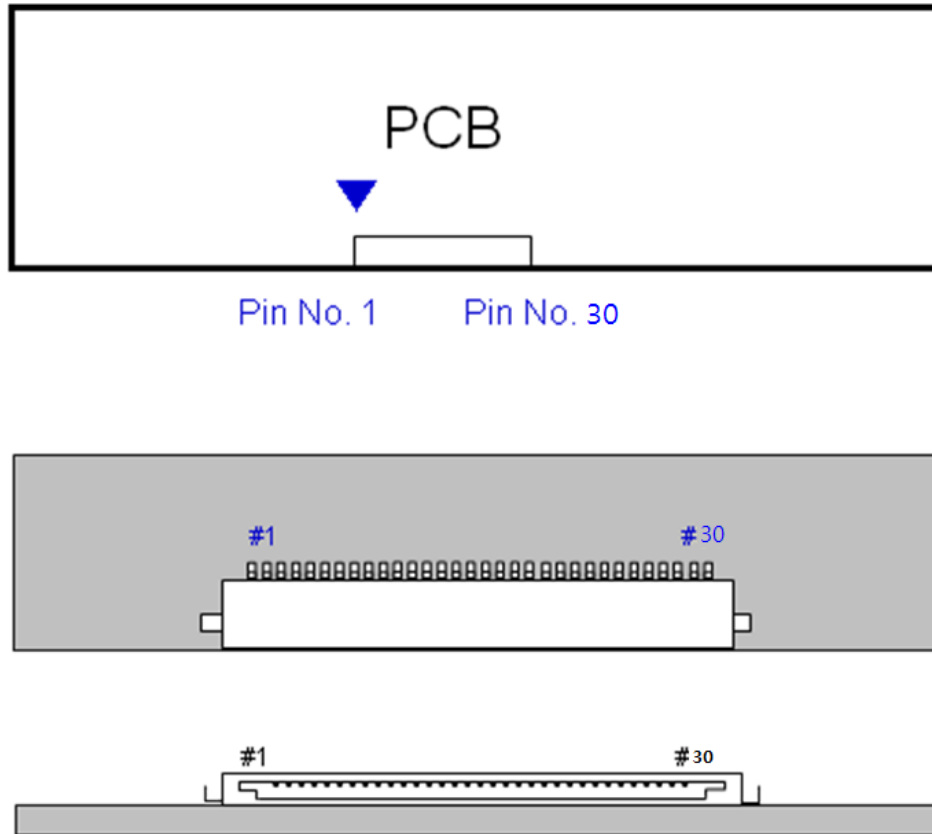

Fig . The diagram of connector

- a. Power GND pins should be connected to the LCD's metal chassis.
- b. All power input pins should be connected together.
- c. All NC pins should be separated from other signal or power.

Note(2) LVDS OPTION : IF THIS PIN : LOW (GND V)/ NC → JEIDA LVDS FORMAT
OTHERWISE : HIGH (3.3V) → NORMAL NS LVDS FORMAT

Note(3) AGING ENABLE PIN / IF THIS PIN **GND** → BIST MODE (ROLLING PATTERN IS OPERATED)

5.2 LVDS Interface

- LVDS receiver : T-con (merged) (8Bit)

- Data format

	LVDS pin	JEIDA -DATA	Normal-DATA
TxOUT/RxIN0	TxIN/RxOUT0	R2	R0
	TxIN/RxOUT1	R3	R1
	TxIN/RxOUT2	R4	R2
	TxIN/RxOUT3	R5	R3
	TxIN/RxOUT4	R6	R4
	TxIN/RxOUT6	R7	R5
	TxIN/RxOUT7	G2	G0
TxOUT/RxIN1	TxIN/RxOUT8	G3	G1
	TxIN/RxOUT9	G4	G2
	TxIN/RxOUT12	G5	G3
	TxIN/RxOUT13	G6	G4
	TxIN/RxOUT14	G7	G5
	TxIN/RxOUT15	B2	B0
	TxIN/RxOUT18	B3	B1
TxOUT/RxIN2	TxIN/RxOUT19	B4	B2
	TxIN/RxOUT20	B5	B3
	TxIN/RxOUT21	B6	B4
	TxIN/RxOUT22	B7	B5
	TxIN/RxOUT24	HSYNC	HSYNC
	TxIN/RxOUT25	VSYNC	VSYNC
	TxIN/RxOUT26	DEN	DE
TxOUT/RxIN3	TxIN/RxOUT27	R0	R6
	TxIN/RxOUT5	R1	R7
	TxIN/RxOUT10	G0	G6
	TxIN/RxOUT11	G1	G7
	TxIN/RxOUT16	B0	B6
	TxIN/RxOUT17	B1	B7
	TxIN/RxOUT23	RESERVED	RESERVED

5.3 Input signals, basic display colors and the gray scale of each color. (8bit)

COLOR	DISPLAY (8bit)	DATA SIGNAL																								GRAY SCALE LEVEL
		RED								GREEN								BLUE								
		R0	R1	R2	R3	R4	R5	R6	R7	G0	G1	G2	G3	G4	G5	G6	G7	B0	B1	B2	B3	B4	B5	B6	B7	
BASIC COLOR	BLACK	0	0	0	0	0	0	0	0	0	0	0	0	0	0	0	0	0	0	0	0	0	0	0	0	-
	BLUE	0	0	0	0	0	0	0	0	0	0	0	0	0	0	0	0	1	1	1	1	1	1	1	1	-
	GREEN	0	0	0	0	0	0	0	0	1	1	1	1	1	1	1	1	0	0	0	0	0	0	0	0	-
	CYAN	0	0	0	0	0	0	0	0	1	1	1	1	1	1	1	1	1	1	1	1	1	1	1	1	-
	RED	1	1	1	1	1	1	1	1	0	0	0	0	0	0	0	0	0	0	0	0	0	0	0	0	-
	MAGENTA	1	1	1	1	1	1	1	1	0	0	0	0	0	0	0	0	1	1	1	1	1	1	1	1	-
	YELLOW	1	1	1	1	1	1	1	1	1	1	1	1	1	1	1	1	0	0	0	0	0	0	0	0	-
	WHITE	1	1	1	1	1	1	1	1	1	1	1	1	1	1	1	1	1	1	1	1	1	1	1	1	-
GRAY SCALE OF RED	BLACK	0	0	0	0	0	0	0	0	0	0	0	0	0	0	0	0	0	0	0	0	0	0	0	R0	
	DARK ↑	1	0	0	0	0	0	0	0	0	0	0	0	0	0	0	0	0	0	0	0	0	0	0	R1	
		0	1	0	0	0	0	0	0	0	0	0	0	0	0	0	0	0	0	0	0	0	0	0	R2	
		:	:	:	:	:	:	:	:	:	:	:	:	:	:	:	:	:	:	:	:	:	:	:	R3~	
		:	:	:	:	:	:	:	:	:	:	:	:	:	:	:	:	:	:	:	:	:	:	:	R252	
	↓ LIGHT	1	0	1	1	1	1	1	1	0	0	0	0	0	0	0	0	0	0	0	0	0	0	0	R253	
		0	1	1	1	1	1	1	1	0	0	0	0	0	0	0	0	0	0	0	0	0	0	0	R254	
	RED	1	1	1	1	1	1	1	1	0	0	0	0	0	0	0	0	0	0	0	0	0	0	0	R255	
GRAY SCALE OF GREEN	BLACK	0	0	0	0	0	0	0	0	0	0	0	0	0	0	0	0	0	0	0	0	0	0	0	G0	
	DARK ↑	0	0	0	0	0	0	0	0	1	0	0	0	0	0	0	0	0	0	0	0	0	0	0	G1	
		0	0	0	0	0	0	0	0	0	1	0	0	0	0	0	0	0	0	0	0	0	0	0	G2	
		:	:	:	:	:	:	:	:	:	:	:	:	:	:	:	:	:	:	:	:	:	:	:	G3~	
		:	:	:	:	:	:	:	:	:	:	:	:	:	:	:	:	:	:	:	:	:	:	:	G252	
	↓ LIGHT	0	0	0	0	0	0	0	0	1	0	1	1	1	1	1	1	0	0	0	0	0	0	0	G253	
		0	0	0	0	0	0	0	0	0	1	1	1	1	1	1	1	0	0	0	0	0	0	0	G254	
	GREEN	0	0	0	0	0	0	0	0	1	1	1	1	1	1	1	1	0	0	0	0	0	0	0	G255	
GRAY SCALE OF BLUE	BLACK	0	0	0	0	0	0	0	0	0	0	0	0	0	0	0	0	0	0	0	0	0	0	0	B0	
	DARK ↑	0	0	0	0	0	0	0	0	0	0	0	0	0	0	0	0	1	0	0	0	0	0	0	B1	
		0	0	0	0	0	0	0	0	0	0	0	0	0	0	0	0	0	1	0	0	0	0	0	B2	
		:	:	:	:	:	:	:	:	:	:	:	:	:	:	:	:	:	:	:	:	:	:	:	B3~	
		:	:	:	:	:	:	:	:	:	:	:	:	:	:	:	:	:	:	:	:	:	:	:	B252	
	↓ LIGHT	0	0	0	0	0	0	0	0	0	0	0	0	0	0	0	0	1	0	1	1	1	1	1	B253	
		0	0	0	0	0	0	0	0	0	0	0	0	0	0	0	0	0	1	1	1	1	1	1	B254	
	BLUE	0	0	0	0	0	0	0	0	0	0	0	0	0	0	0	0	1	1	1	1	1	1	1	B255	

Note) The definition of gray :

Rn : Red gray, Gn : Green gray, Bn : Blue gray (n = Gray level)

Input signal : 0 = Low level voltage, 1 = High level voltage

5.4 LVDS receiver : T-con (merged) (8Bit)
- Data format

	LVDS pin	JEIDA -DATA	Normal -DATA
TxOUT/RxIN0	TxIN/RxOUT0	R2	R0
	TxIN/RxOUT1	R3	R1
	TxIN/RxOUT2	R4	R2
	TxIN/RxOUT3	R5	R3
	TxIN/RxOUT4	R6	R4
	TxIN/RxOUT6	R7	R5
	TxIN/RxOUT7	G2	G0
TxOUT/RxIN1	TxIN/RxOUT8	G3	G1
	TxIN/RxOUT9	G4	G2
	TxIN/RxOUT12	G5	G3
	TxIN/RxOUT13	G6	G4
	TxIN/RxOUT14	G7	G5
	TxIN/RxOUT15	B2	B0
	TxIN/RxOUT18	B3	B1
TxOUT/RxIN2	TxIN/RxOUT19	B4	B2
	TxIN/RxOUT20	B5	B3
	TxIN/RxOUT21	B6	B4
	TxIN/RxOUT22	B7	B5
	TxIN/RxOUT24	HSYNC	HSYNC
	TxIN/RxOUT25	VSYNC	VSYNC
	TxIN/RxOUT26	DEN	DE
TxOUT/RxIN3	TxIN/RxOUT27	R0	R6
	TxIN/RxOUT5	R1	R7
	TxIN/RxOUT10	G0	G6
	TxIN/RxOUT11	G1	G7
	TxIN/RxOUT16	B0	B6
	TxIN/RxOUT17	B1	B7
	TxIN/RxOUT23	RESERVED	RESERVED
TxOUT/RxIN4(dithered10bit)	TxIN/RxOUT28	R0	R8
	TxIN/RxOUT29	R1	R9
	TxIN/RxOUT30	G0	G8
	TxIN/RxOUT31	G1	G9
	TxIN/RxOUT32	B0	B8
	TxIN/RxOUT33	B1	B9
	TxIN/RxOUT34	RESERVED	RESERVED

5.5 Input signals, basic display colors and the gray scale of each color. (10bit)

COLOR	DISPLAY	DATA SIGNAL																											GRAY SCALE LEVEL			
		RED									GREEN									BLUE												
		R0	R1	R2	R3	R4	R5	R6	R7	R8	R9	G0	G1	G2	G3	G4	G5	G6	G7	G8	G9	B0	B1	B2	B3	B4	B5	B6		B7	B8	B9
BASIC COLOR	BLACK	0	0	0	0	0	0	0	0	0	0	0	0	0	0	0	0	0	0	0	0	0	0	0	0	0	0	0	0	0	-	
	BLUE	0	0	0	0	0	0	0	0	0	0	0	0	0	0	0	0	0	0	0	0	0	1	1	1	1	1	1	1	1	1	-
	GREEN	0	0	0	0	0	0	0	0	0	0	1	1	1	1	1	1	1	1	1	1	1	0	0	0	0	0	0	0	0	0	-
	CYAN	0	0	0	0	0	0	0	0	0	0	1	1	1	1	1	1	1	1	1	1	1	1	1	1	1	1	1	1	1	1	-
	RED	1	1	1	1	1	1	1	1	1	1	0	0	0	0	0	0	0	0	0	0	0	0	0	0	0	0	0	0	0	0	-
	MAGENTA	1	1	1	1	1	1	1	1	1	1	0	0	0	0	0	0	0	0	0	0	0	1	1	1	1	1	1	1	1	1	-
	YELLOW	1	1	1	1	1	1	1	1	1	1	1	1	1	1	1	1	1	1	1	1	1	0	0	0	0	0	0	0	0	0	-
	WHITE	1	1	1	1	1	1	1	1	1	1	1	1	1	1	1	1	1	1	1	1	1	1	1	1	1	1	1	1	1	1	-
GRAY SCALE OF RED	BLACK	0	0	0	0	0	0	0	0	0	0	0	0	0	0	0	0	0	0	0	0	0	0	0	0	0	0	0	0	0	R0	
	DARK ↑	1	0	0	0	0	0	0	0	0	0	0	0	0	0	0	0	0	0	0	0	0	0	0	0	0	0	0	0	0	R1	
		0	1	0	0	0	0	0	0	0	0	0	0	0	0	0	0	0	0	0	0	0	0	0	0	0	0	0	0	0	R2	
		:	:	:	:	:	:	:	:	:	:	:	:	:	:	:	:	:	:	:	:	:	:	:	:	:	:	:	:	:	:	R3~
		:	:	:	:	:	:	:	:	:	:	:	:	:	:	:	:	:	:	:	:	:	:	:	:	:	:	:	:	:	:	R1020
	LIGHT ↓	1	0	1	1	1	1	1	1	1	1	0	0	0	0	0	0	0	0	0	0	0	0	0	0	0	0	0	0	0	R1021	
		0	1	1	1	1	1	1	1	1	1	0	0	0	0	0	0	0	0	0	0	0	0	0	0	0	0	0	0	0	0	R1022
	RED	1	1	1	1	1	1	1	1	1	1	0	0	0	0	0	0	0	0	0	0	0	0	0	0	0	0	0	0	0	0	R1023
GRAY SCALE OF GREEN	BLACK	0	0	0	0	0	0	0	0	0	0	0	0	0	0	0	0	0	0	0	0	0	0	0	0	0	0	0	0	0	G0	
	DARK ↑	0	0	0	0	0	0	0	0	0	0	1	0	0	0	0	0	0	0	0	0	0	0	0	0	0	0	0	0	0	0	G1
		0	0	0	0	0	0	0	0	0	0	0	1	0	0	0	0	0	0	0	0	0	0	0	0	0	0	0	0	0	0	G2
		:	:	:	:	:	:	:	:	:	:	:	:	:	:	:	:	:	:	:	:	:	:	:	:	:	:	:	:	:	:	G3~
		:	:	:	:	:	:	:	:	:	:	:	:	:	:	:	:	:	:	:	:	:	:	:	:	:	:	:	:	:	:	G1020
	LIGHT ↓	0	0	0	0	0	0	0	0	0	0	1	0	1	1	1	1	1	1	1	1	1	0	0	0	0	0	0	0	0	0	G1021
		0	0	0	0	0	0	0	0	0	0	0	1	1	1	1	1	1	1	1	1	1	0	0	0	0	0	0	0	0	0	G1022
	GREEN	0	0	0	0	0	0	0	0	0	0	1	1	1	1	1	1	1	1	1	1	1	0	0	0	0	0	0	0	0	0	G1023
GRAY SCALE OF BLUE	BLACK	0	0	0	0	0	0	0	0	0	0	0	0	0	0	0	0	0	0	0	0	0	0	0	0	0	0	0	0	0	B0	
	DARK ↑	0	0	0	0	0	0	0	0	0	0	0	0	0	0	0	0	0	0	0	0	0	1	0	0	0	0	0	0	0	0	B1
		0	0	0	0	0	0	0	0	0	0	0	0	0	0	0	0	0	0	0	0	0	0	1	0	0	0	0	0	0	0	B2
		:	:	:	:	:	:	:	:	:	:	:	:	:	:	:	:	:	:	:	:	:	:	:	:	:	:	:	:	:	:	B3~
		:	:	:	:	:	:	:	:	:	:	:	:	:	:	:	:	:	:	:	:	:	:	:	:	:	:	:	:	:	:	B1020
	LIGHT ↓	0	0	0	0	0	0	0	0	0	0	0	0	0	0	0	0	0	0	0	0	0	1	0	1	1	1	1	1	1	1	B1021
		0	0	0	0	0	0	0	0	0	0	0	0	0	0	0	0	0	0	0	0	0	0	1	1	1	1	1	1	1	1	B1022
	BLUE	0	0	0	0	0	0	0	0	0	0	0	0	0	0	0	0	0	0	0	0	0	1	1	1	1	1	1	1	1	1	B1023

Note) The definition of gray :

Rn : Red gray, Gn : Green gray, Bn : Blue gray (n = Gray level)

Input signal : 0 = Low level voltage, 1 = High level voltage

6. Interface timing

6.1 The parameters of timing (Only DE mode)

SIGNAL	ITEM	SMBOL	MIN.	TYP.	MAX.	Unit	NOTE
Clock	Frequency	$1/T_C$	72	78	85	MHz	-
Hsync		F_H	44	48	53	KHz	-
Vsync		F_V	48	60	66	Hz	-
Term for the vertical display	Active display period	T_{VD}	-	768	-	Lines	-
	Total vertical	T_V	780	802	1200	Lines	-
Term for the horizontal display	Active display period	T_{HD}	-	1368	-	Clocks	-
	Total Horizontal	T_H	1480	1624	2000	clocks	-

Note) These products don't have to receive the signal of Hsync & Vsync from the input device.

- (1) Key points when testing: TTL controls the signal and the CLK at the input terminal of LVDS Tx of the system.
 - (2) Internal VDD = 3.3V
 - (3) Spread spectrum
- The limit of spread spectrum's range of SET in which the LCD module is assembled should be within $\pm 3\%$.

TxOUT/RxIN4(dithered10bit)	TxIN/RxOUT28	R0	R8
	TxIN/RxOUT29	R1	R9
	TxIN/RxOUT30	G0	G8
	TxIN/RxOUT31	G1	G9
	TxIN/RxOUT32	B0	B8
	TxIN/RxOUT33	B1	B9
	TxIN/RxOUT34	RESERVED	RESERVED

6.2 Timing diagrams of interface signal (Only DE mode)

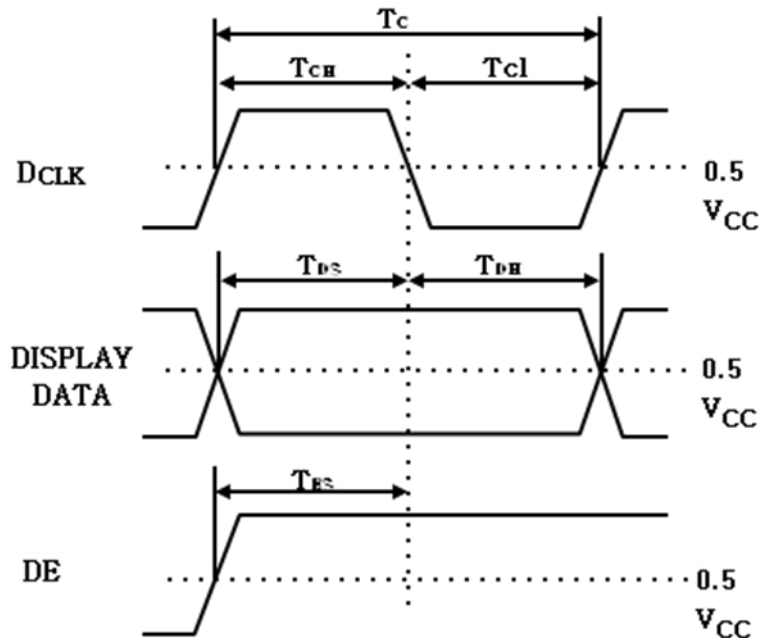
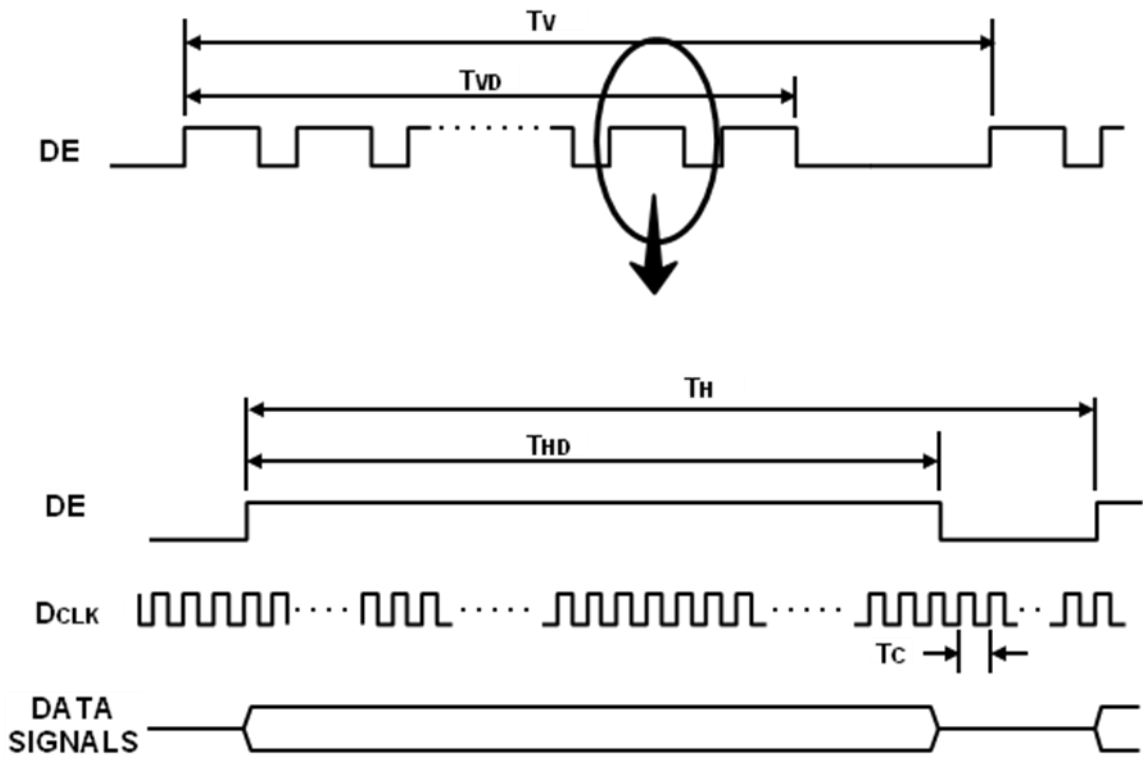

6.3 Characteristics of Input data of LVDS

ITEM	SYMBOL	Min.	Typ.	Max.	UNIT	NOTE
Differential input high threshold voltage	V _{TH}	-	-	+100	mV	V _{CM} = 1.2V
Differential input low threshold voltage	V _{TL}	-100	-	-	mV	
Input common mode voltage	V _{CM}	0.2	1.2	2.0	V	-
Differential Input Voltage	V _{ID}	100	-	600	mV	V _{ID} = 100mV
Input data position	F _{IN} = 78MHz	t _{RSRM}	-	-	450	ps
		t _{RSLM}	-450	-		ps

Notice The spread spectrum should be 0% when the skew is measured.

Position of a measurement is T-CON LVDS input pin

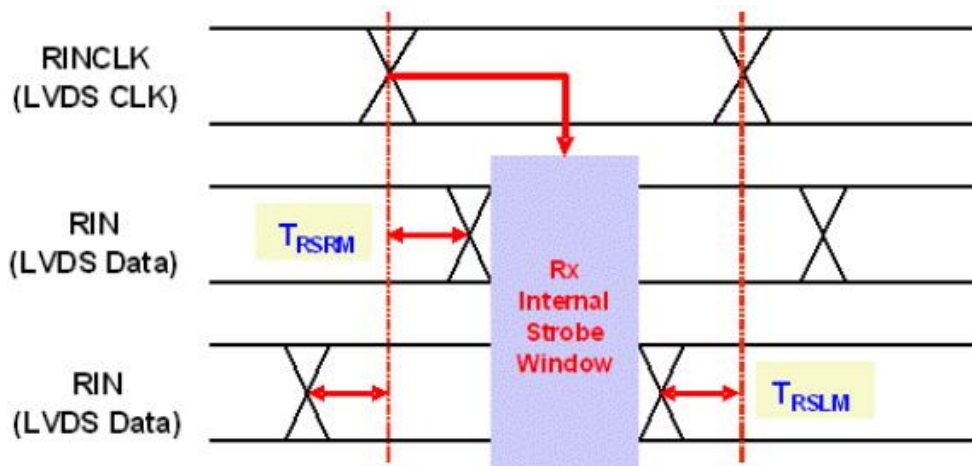
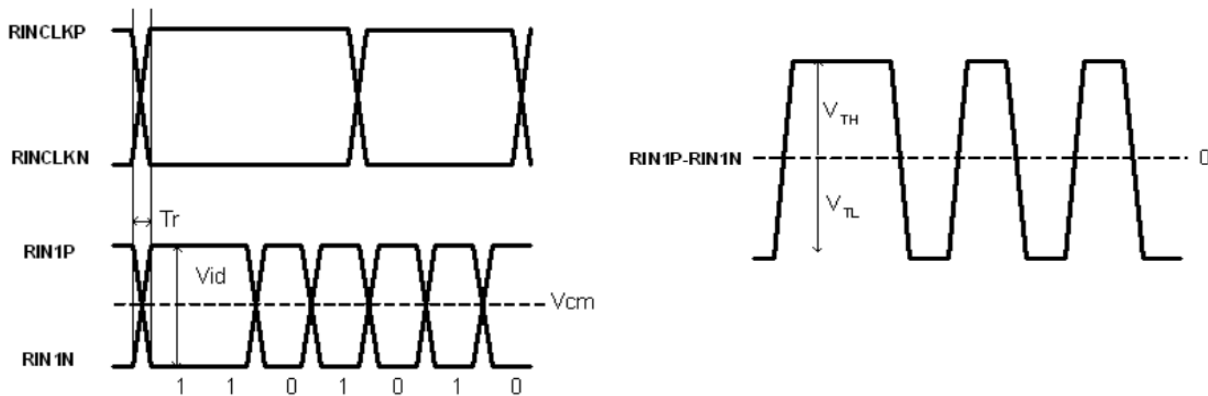

6.4 The sequence of power on and off

To prevent a latch-up phenomena or the DC operation of the LCD Module, the power on/off sequence should be accorded with the settings described in the diagram below.

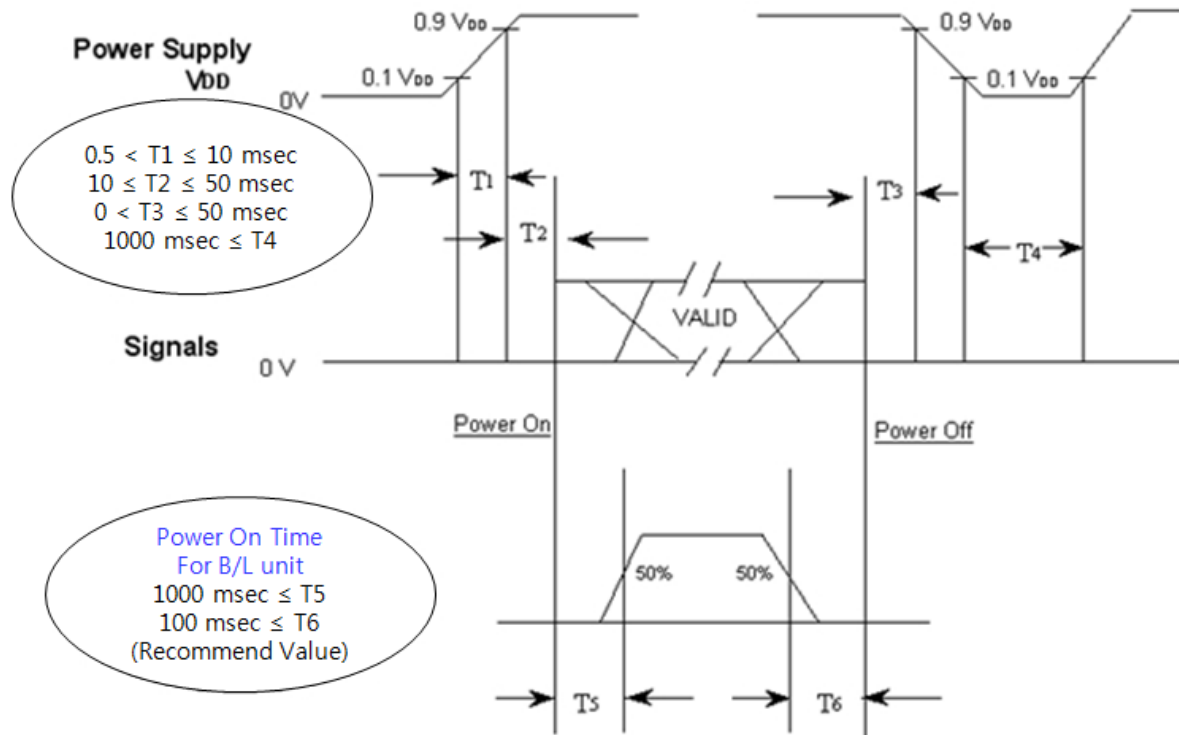

T1 : The V_{DD} rising time from 10% to 90%

T2 : The time from the point which V_{DD} reach to 90% of voltage to the point which the valid data is out when the power is on.

T3: The time from the point which the valid data is out to the point which V_{DD} reach to the 90% of voltage when the power is off.

T4: the time from the point which the V_{DD} decrease to the point which the V_{DD} increase again for windows to restart.

※ The recommended operating condition of the back light system

T5: The time which takes for B/L to be turned on after the signal is entered when the time is on.

T6 : The time which takes until the signal is out after BL is turned off

- The condition of supply voltage to enter in the module from the external system should have the same condition as the definition of V_{DD}.
- Apply the voltage for the lamp within the range which the LCD operates. when the back light is turned on before the LCD is operated or when the LCD is turned off before the back light is turned off, the display may show the abnormal screen momentarily.
- While the V_{DD} is off level, please keep the level of input signals low or keep a high impedance condition.
- The figure of T4 should be measured after the module has been fully discharged between the periods when the power is on and off.
- The interface signal must not keep the high impedance condition when the power is on.

7. Outline dimension

7.1 The adhesive size of POL

The next figure shows the size of POL on the drawing sheet attached to the panel for BLU design.

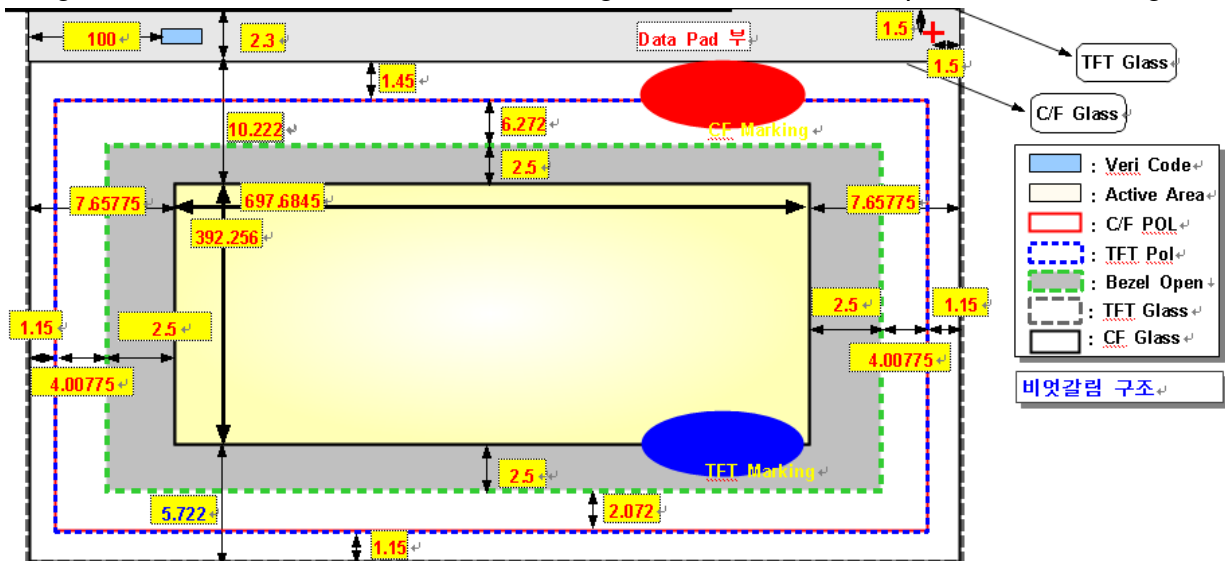

<Figure.>

The POL size of CF : 710.7 X 405.6 ± 0.5mm

The POL size of TFT: 710.7 X 405.6 ± 0.5mm

The total adhesion allowance of POL is ± 1.15mm

7.2 The drawing sheet for the size of the OLB bonding

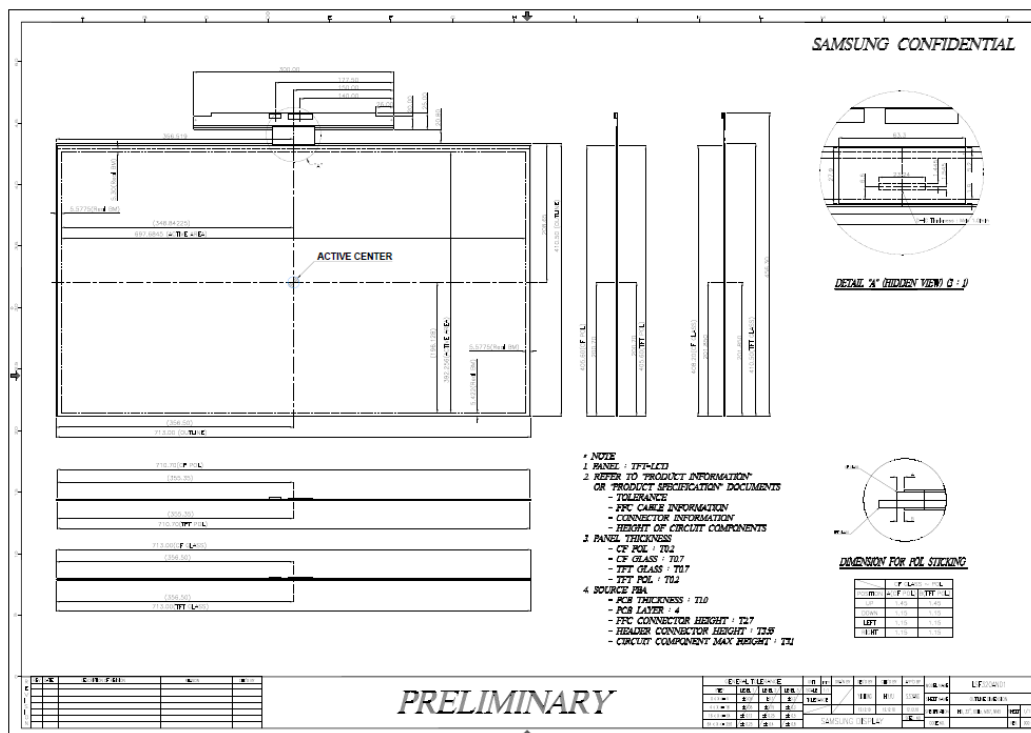

8. Reliability test

8.1 Panel

Item	Test Condition	Quantity	Note						
HTOL	60 °C (Panel change 500hr / circuit change 250hr)	8							
LTOL	-5 °C (Panel change 500hr / circuit change 250hr)	4							
THB	50 °C / 90 %RH(Panel change 500hr / circuit change 250hr)	10							
ASG Low temperature	Max. frequency 25°C~-40°C	Each Cell	ASG Product Only						
ASG High Temperature	Min. frequency 60°Coperation 96hr	Each Cell	ASG Product Only						
Image sticking	25 °C / Mosaic pattern(9*10) 12hrs	8							
	Rolling pattern 12hrs / 3cycles								
Decompression	-40~50°C, 0m(0ft) ~ 13,700m(45,000ft), 72.5Hr	4							
HTS	70 °C, Storage (Panel change 500hr / circuit change 250hr)	4							
LTS	-25 °C, Storage(Panel change 500hr / circuit change 250hr)	4							
Transportation condition	drop(20cm) → temperature/humidity(-30~60°C / 40°C 90%RH) → pressure → vibration(5~200Hz 1.05Grms, 2hr) → drop(20cm)	1pallet							
WHTS	60 °C / 75 %RH , Storage	4							
Noise	Electromagnetic noise: Overall 23dB 이하	2							
Complex stress	-20°C~60°C, 0~90%RH, 2cycle	4							
ESD	S-IC Input ±7KV, Output ±4KV Output 은 data TP 에 직접 인가 후 진행 Input 은 CKV,VCOM 등에 FFC CNT 를 통하여 TEST 를 진행	3							
EOS (optional)	<table border="1"> <thead> <tr> <th>Item</th> <th>Test condition</th> </tr> </thead> <tbody> <tr> <td>Vin Input step</td> <td>Surge combination (High impedance) Pass Condition: 5kV under</td> </tr> <tr> <td>Signal Input step</td> <td>Surge combination (High impedance) Pass Condition: 120V under</td> </tr> </tbody> </table>	Item	Test condition	Vin Input step	Surge combination (High impedance) Pass Condition: 5kV under	Signal Input step	Surge combination (High impedance) Pass Condition: 120V under	2	
	Item	Test condition							
	Vin Input step	Surge combination (High impedance) Pass Condition: 5kV under							
Signal Input step	Surge combination (High impedance) Pass Condition: 120V under								

[Criteria on evaluation]

There should be no change of the product, which may affect to the practical display functions, when the display quality test is executed under the normal operation setting.

* HTOL/ LTOL : The operating cycle on the high and low temperature

* THB : Temperature humidity slant

* HTS/LTS : The storage at the high and low temperature

* WHTS : The storage in the high temperature with the high humidity

MODEL	LSC320AN03	Doc. No		Page	22 / 23
-------	------------	---------	--	------	---------



MODEL	LSC320AN03	Doc. No		Page	23 / 23
-------	------------	---------	--	------	---------