

# **SPECIFICATIONS FOR LED DISPLAYS**

**7.8mm(0.30") Seven Segments Single Digit**

**LSD030 -10 Series**

**WENRUN OPTOELECTRONIC**

www.DataSheet4U.com

**Features:**

- High efficiency, low power consumption.
- Extremely low current.
- Luminous evenly distributed on each segment.
- Low development cost.

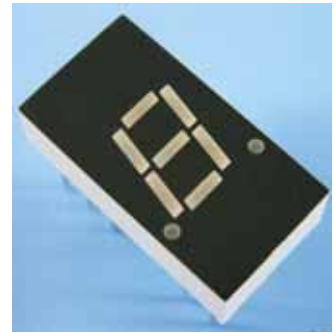

**LSD030A/B/C/D/E/F/K/L -10**

**Descriptions:**

- Industrial standard size.
- These display provide excellent reliability in bright ambient light.
- These devices are made with white segments and black surface.



**LSD030G/H -10**

**Applications:**

- Audio equipment or Instrument panels.
- General use for digital indicators.
- Multimedia product.

**Selection Guide:**

Part No.		Chip		Lens Color
Anode	Cathode	Material	Emitting Color	
LSD030B/D/F/H/LSR-10	LSD030A/C/E/G/KSR-10	GaAlAs	Super Red	White Diffused
LSD030B/D/F/H/LG-10	LSD030A/C/E/G/KG-10	GaP	Green	

www.DataSheet4U.com

**Absolute Maximum Rating ( Ta=25 )**

Parameter	Symbol	Super Red	Green	Unit
Power Dissipation/Segment	$P_d$	50	60	mW
Peak Forward Current /Segment (Duty 1/10@ 1KHz)	$I_{FP}$	70	70	mA
Continuous Forward Current /Segment	$I_F$	20	20	mA
Recommend use current /Segment	$I_F$	5~10	5~10	mA
Reverse Voltage /Segment	$V_R$	5	5	V
Operating Temperature Range	$T_{opr}$	-25~ +75		
Storage Temperature Range	$T_{stg}$	-30 ~ +85		
Solder Temperature	$T_{sol}$	260 ± 5		

- Notes :**
- 1、 This is the limit current . It is not allowed to use when the product work continuously.
  - 2、 It is recommended that the product is driven by TTL,CMOS.
  - 3、 Soldering time 5 seconds.

**Electrical Optical Characteristics ( Ta=25 )**

Parameter	Symbol	Super Red		Green		Unit	Test Condition
		Typ.	Max.	Typ.	Max.		
Luminous Intensity /Segment	$I_V$	5.0	--	2.5	--	mcd	$I_F=10mA$
Forward Voltage /Segment	$V_F$	1.85	2.3	2.2	2.5	V	$I_F=20mA$
Reverse Current /Segment	$I_R$	--	50	--	50	uA	$V_R=5V$
Dominant Wavelength	$\lambda_d$	645	--	565	--	nm	$I_F=20mA$
Spectral Line Half Width		30	--	30	--	nm	$I_F=20mA$

www.DataSheet4U.com

**Package Dimensions:**

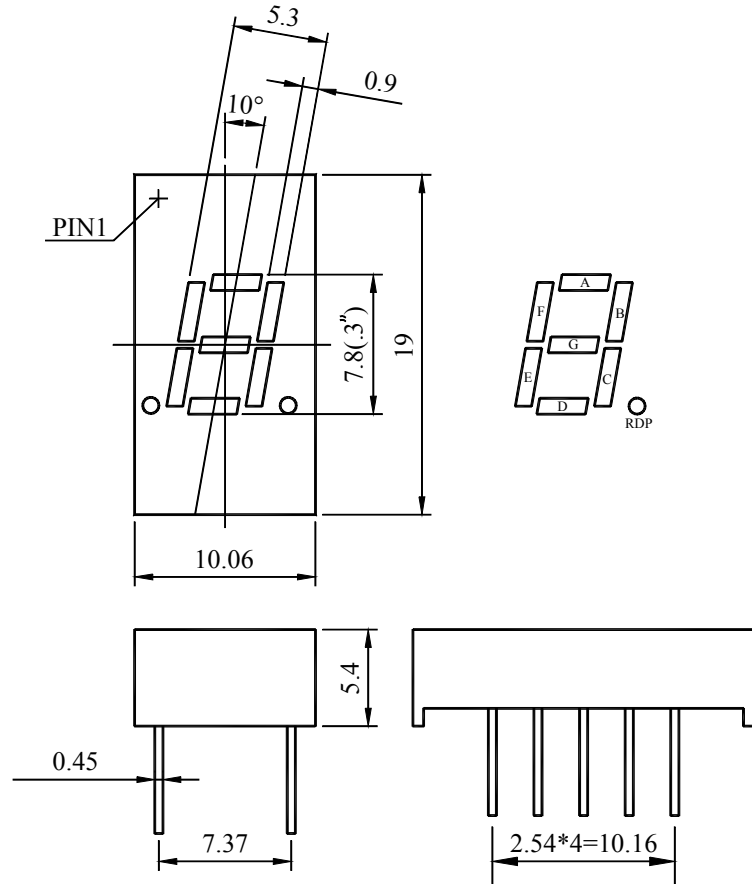

**NOTES :**

- All dimensions are in millimetres (mm), Tolerance is  $\pm 0.25\text{mm}$  unless otherwise noted.
- Specifications are subject to change without notice.

**Internal Circuit:**

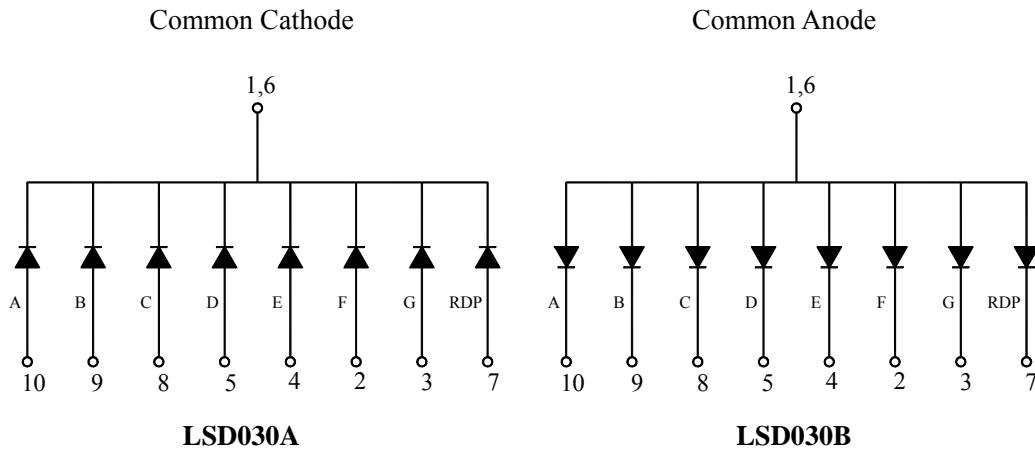

www.DataSheet4U.com

**Package Dimensions:**

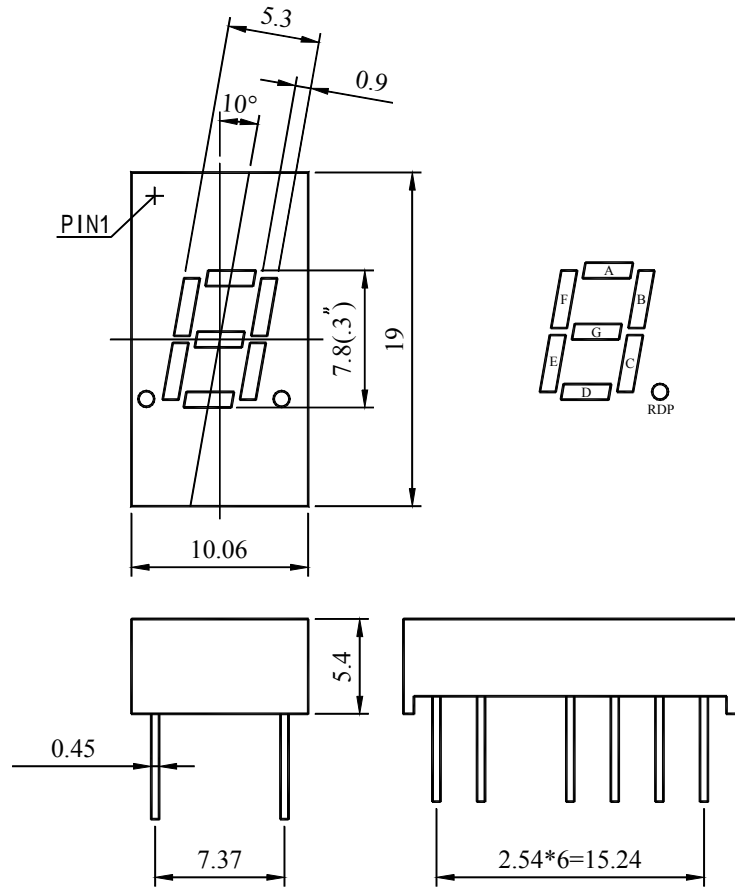

**NOTES :**

- All dimensions are in millimetres (mm), Tolerance is  $\pm 0.25\text{mm}$  unless otherwise noted.
- Specifications are subject to change without notice.

**Internal Circuit:**

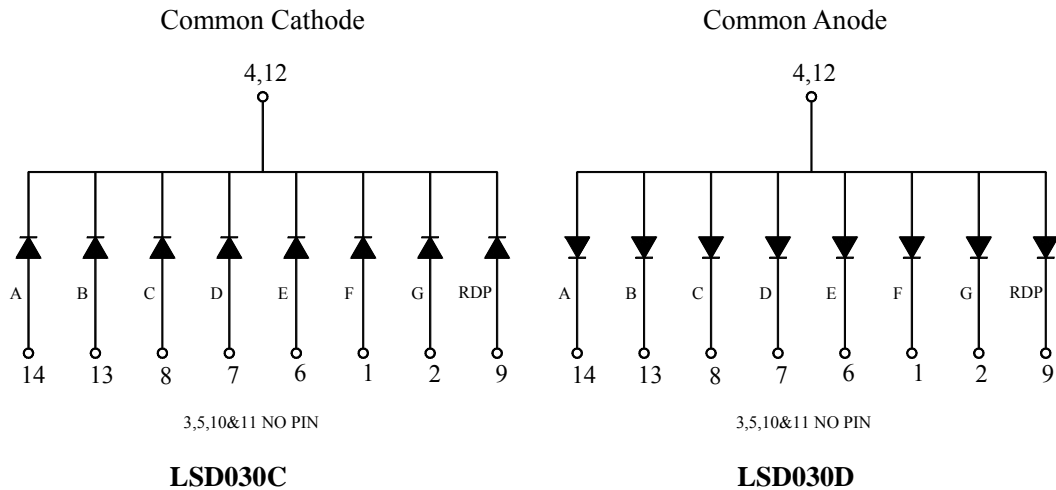

www.DataSheet4U.com

**Package Dimensions:**

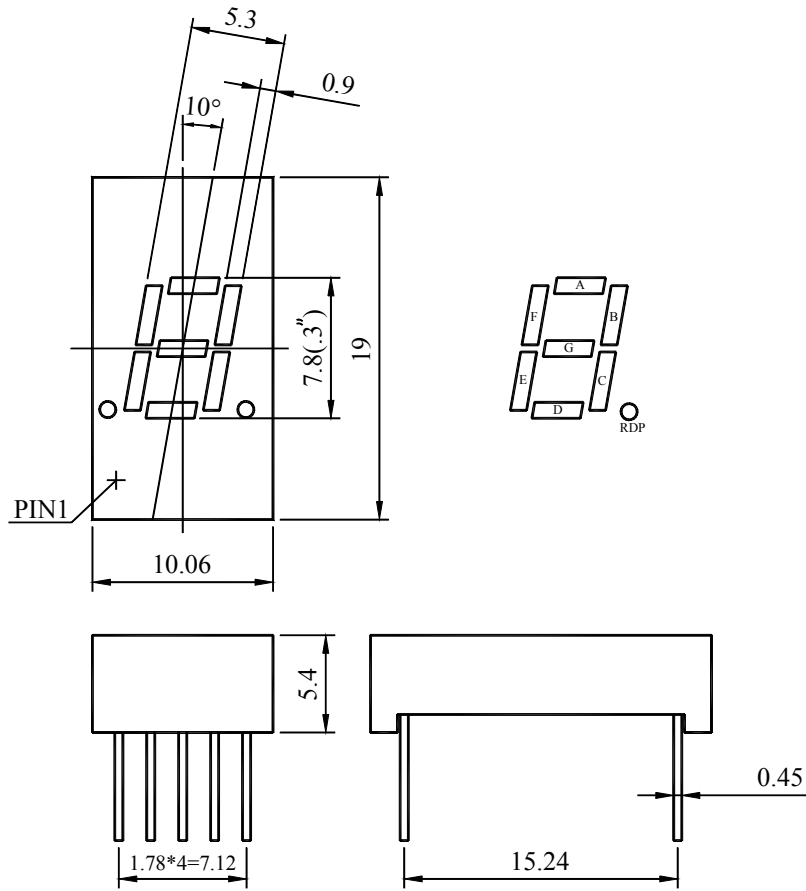

**NOTES :**

- All dimensions are in millimetres (mm), Tolerance is  $\pm 0.25\text{mm}$  unless otherwise noted.
- Specifications are subject to change without notice.

**Internal Circuit:**

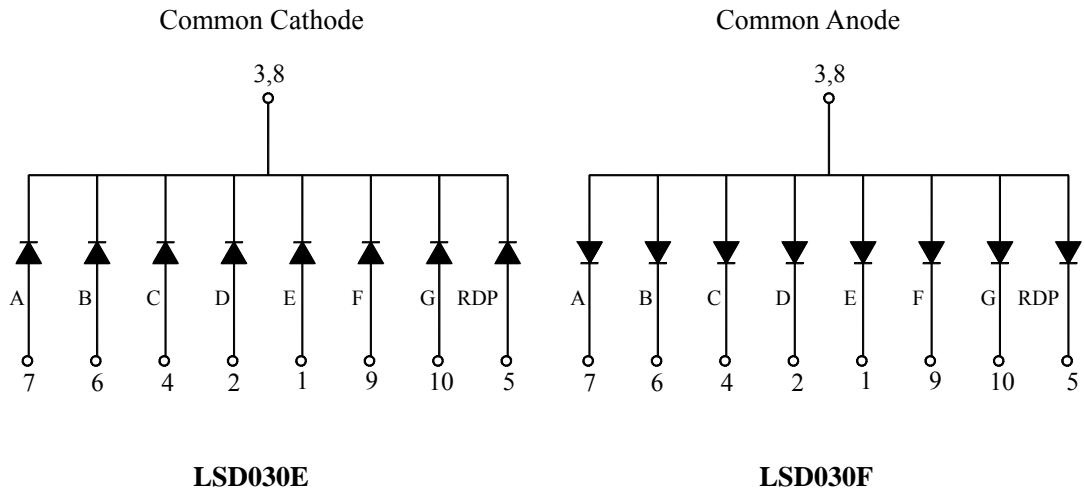

www.DataSheet4U.com

**Package Dimensions:**

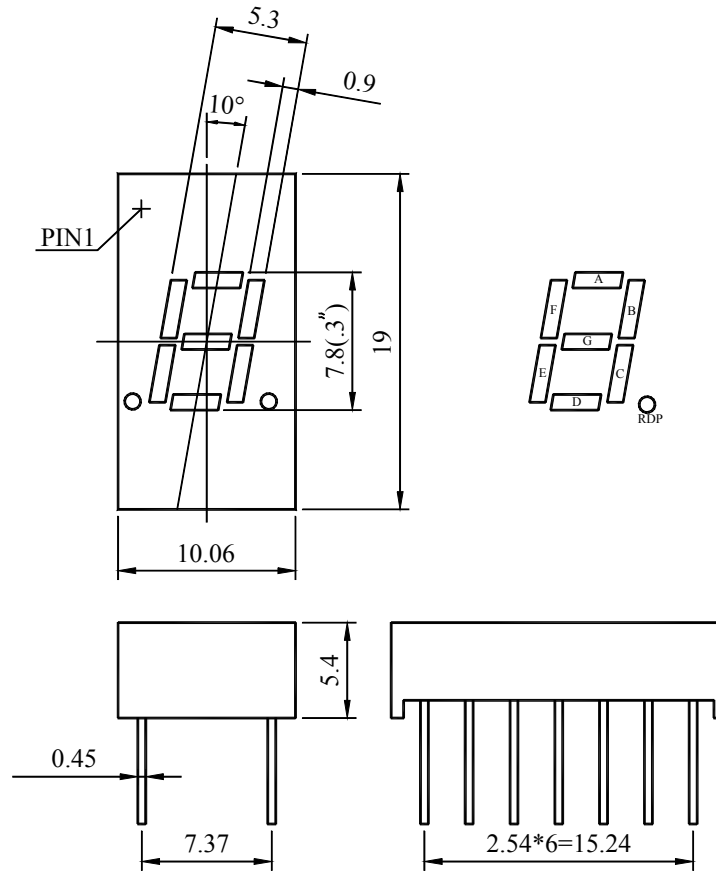

**NOTES :**

- All dimensions are in millimetres (mm), Tolerance is  $\pm 0.25\text{mm}$  unless otherwise noted.
- Specifications are subject to change without notice.

**Internal Circuit:**

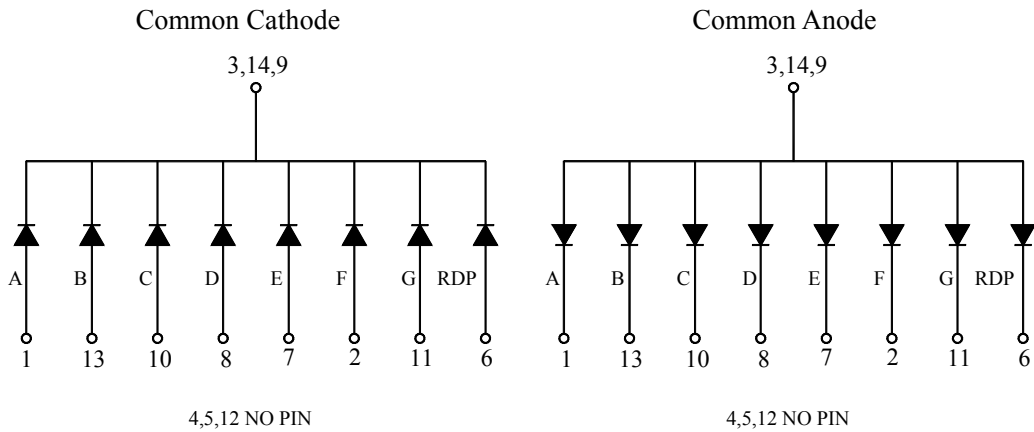

**LSD030K**

**LSD030L**

www.DataSheet4U.com

**Package Dimensions:**

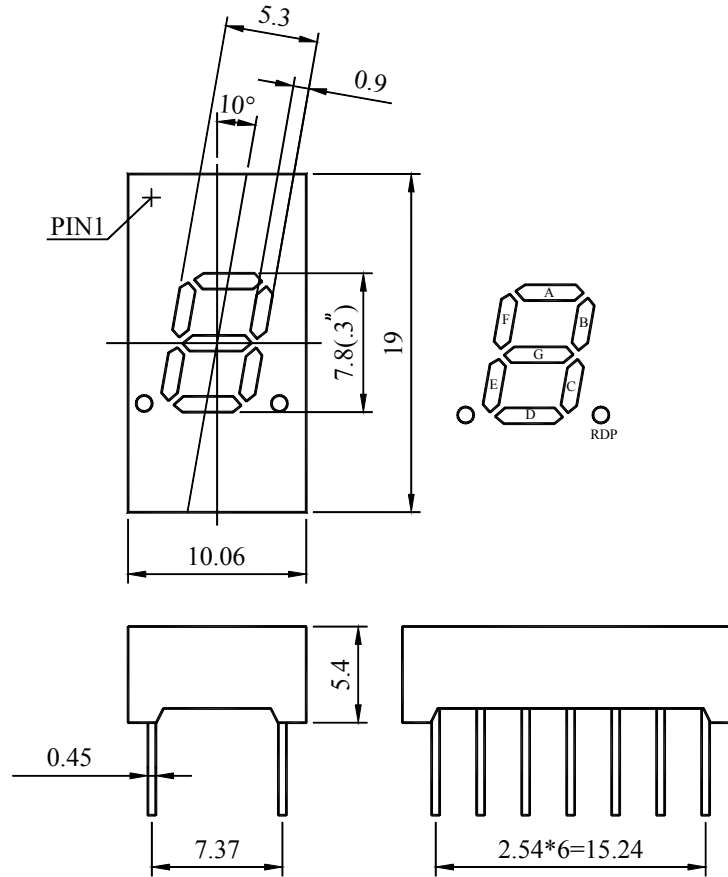

**NOTES :**

- All dimensions are in millimetres (mm), Tolerance is  $\pm 0.25\text{mm}$  unless otherwise noted.
- Specifications are subject to change without notice.

**Internal Circuit:**

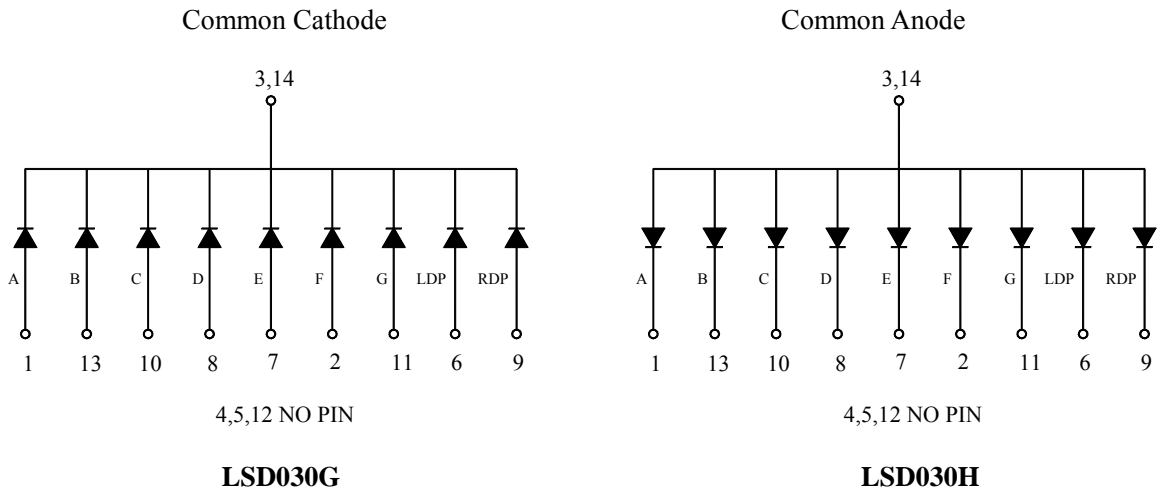



www.DataSheet4U.com

### Reliability Test Items and Conditions

NO	Test Item	Test Conditions	Duration	Sample	Ac/Re
1	Temperature Cycle	-30 ~ 25 ~ 85 ~ 25 30min 5min 30min 5min	50cycles	100	0/1
2	High Temp. Storage	Ta=85	1000hours	100	0/1
3	Temp.& Humidity Test	Ta=85 RH=85%	1000hours	100	0/1
4	Low Temp. Storage	Ta=-30	1000hours	100	0/1
5	Operating Life Test	Ta=25 ± 5 DC IF=15mA	1000hours	100	0/1
6	Solder Heat	Tsol=260 ± 5 , 10s	1times	20	0/1

### Typical Electro-Optical Characteristics Curves

Spectrum Distribution

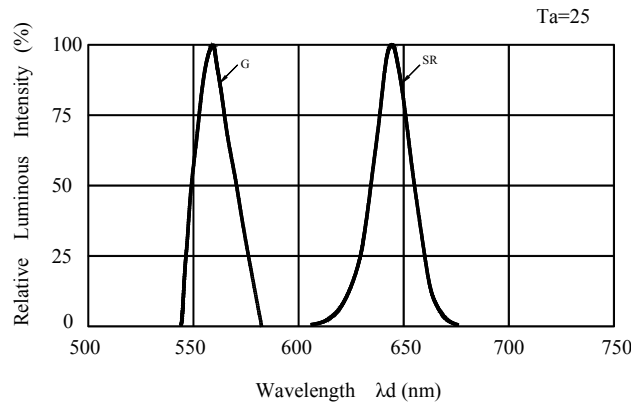

Forward Current vs. Forward Voltage

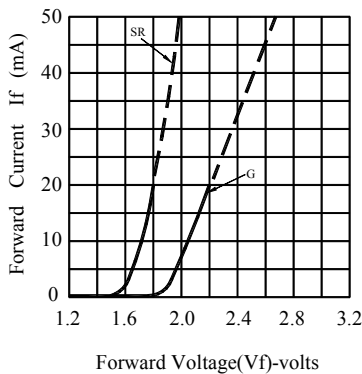

Forward Current Derating Curve

