

LSI53C896 ULTRA2 SCSI CONTROLLER

The Communications Company™

PCI-DUAL CHANNEL ULTRA2 SCSI MULTIFUNCTION CONTROLLER



OVERVIEW

In the fast-growing server and workstation marketplace, higher levels of performance and integration are required to stay competitive. As a result, data accessibility and the subsequent performance of the I/O subsystem are paramount. To meet these market demands, LSI Logic developed the LSI53C896 controller. This highly integrated single-chip solution provides compute and data intensive designs a full featured SCSI solution for embedding on the mainboard or as a host adapter.

APPLICATIONS

- *Servers* – Internet/Intranet network, video, e-mail, printing, database management, etc.
- *Workstations* – CAD/CAM, industrial simulation, etc.
- *Host attach for RAID and JBOD mass storage subsystems* – Anywhere data access is the bottleneck

SDMS SOFTWARE FOR THE LSI53C896

Most high-performance storage subsystems require hardware, firmware and software components to create a total I/O solution. To be of value, the solution must interoperate across the wide range of operating and computing systems available. It is for this reason SDMS™ software supports the LSI53C896 to provide a complete high-performance SCSI I/O solution. SDMS software has been certified for, and in most cases bundled with, leading operating systems. Likewise, the LSI logic BIOS is easily integrated and coexists with popular industry system BIOS offerings as well as providing boot capabilities for nontraditional boot devices like CD-ROMS.

BENEFITS

- Ultra2 SCSI performance up to 160 MBps aggregate throughput
- Two Ultra2 SCSI channels allow peripherals to be organized to optimize storage characteristics and performance
- LVDlink™ transceivers provide the data reliability and cable distances expected from differential signaling
- Fully supported with Storage Device Management System (SDMS™) software
- Local memory and expansion buses reduce PCI overhead when instructions are fetched locally
- Supports PC99 and Power Management 1.1

LSI53C896 Ultra2 SCSI Controller

FEATURES

- High-performance PCI multifunction device
 - Presents one electrical load to PCI bus
 - Frees up PC board space for other functions
- Two independent wide Ultra2 SCSI channels support:
 - Up to 80 MBps transfer rate for each channel
 - Wide range of signaling environments
 - Low Voltage Differential (LVD)
 - High Voltage Differential (HVD)
 - Single-ended (SE)
 - Or any combination of the above
- Integrated LVDlink SCSI transceivers
- 8 KB SCRIPTS RAM on each channel
- 944-byte DMA FIFO on each channel
- Five general purpose I/O pins for each SCSI channel
- 64-bit SCRIPTS™ addressing

SDMS software was designed using a modular approach for quick development, validation and support for new OS versions as well as the LSI53C896. To round out the SDMS solution, LSI Logic also provides installation and configuration, non utilities, user documentation for each OS, plus timely and knowledgeable technical support. For performance, SDMS software takes advantage of the I/O processing capabilities of the LSI53C896 to support target disconnect/reselect, synchronous and wide SCSI operation and multiple host adapters. With operating systems like Windows® NT® and SCO Open Server, SDMS software supports one processor interrupt per I/O.

Drivers are available for NetWare®, Windows® NT® 4.0, DOS, Windows 95/98, UnixWare™, OS/2 Warp, Solaris™, and Linux.

LSI53CS96 BLOCK DIAGRAM AND APPLICATION EXAMPLE

Figure 1 is a functional block diagram of the LSI53C896 controller.

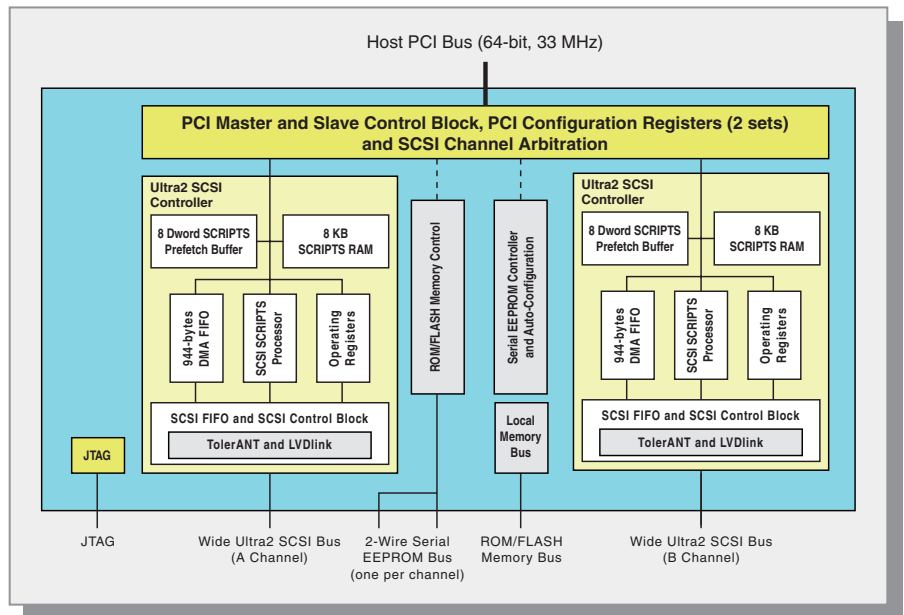

Figure 1. LSI53C896 functional block diagram

Figure 2 describes a general application of the LSI53C896 allowing it to operate with SDMS and legacy software. Note that each SCSI channel can attach up to 15 Ultra2 SCSI peripherals to a 12 meter cable with a SCSI transfer rate of up to 80 MBPS.

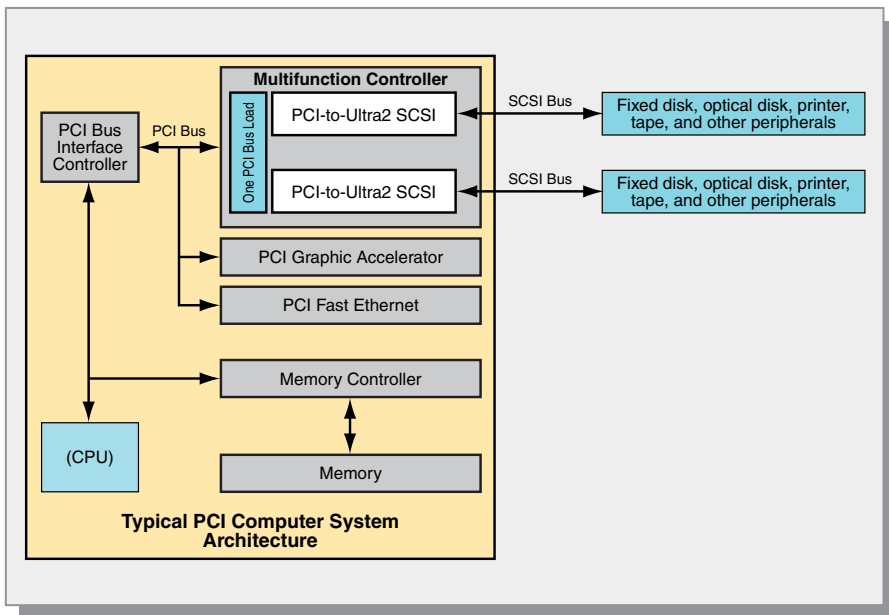

Figure 2. LSI53C896 general application

FEATURES (Continued)

- Hardware handling of SCSI bus phase mismatches reduces CPU utilization
- Interrupt disabling while SCRIPTS are running
- Supports LSI Logic's Nextreme™ RAID
- SCSI Interrupt Steering Logic (SISL) alternate interrupt routing for RAID applications
- 64-bit, 33 MHz PCI Bus Mastering Interface
 - Theoretical 264 MBps zero wait state transfer rate
 - Dual Address Cycle (DAC) supported for 64-bit addressing
- 40 MHz SCSI clock
- JTAG boundary scan
- Flash and local memory interface
- Packaged in a 329 PBGA
 - Auto-download of PCI Subsystem and Subsystem Vendor ID Register
 - PCI Power Management Levels with DO-D3 support, Extended Capabilities Registers

LSI53C896 Ultra2 SCSI Controller

For more information please visit
the LSI Logic web site at:

<http://storageio.lsilogic.com>

LSI Logic Corporation

North American Headquarters
Milpitas, CA
Tel: 800 574 4286

LSI Logic Europe Ltd.

European Headquarters
United Kingdom
Tel: 44 1344 426544
Fax: 44 1344 481039

LSI Logic KK Headquarters

Tokyo, Japan
Tel: 81 3 5463 7165
Fax 81 3 5463 7820

ISO 9000 Certified

LSI Logic logo design and TolerANT are registered trademarks, and LVDlink, Nextreme, SCRIPTS, and SDMS are trademarks of LSI Logic Corporation. All other brand and product names may be trademarks of their respective companies.

LSI Logic Corporation reserves the right to make changes to any products and services herein at any time without notice. LSI Logic does not assume any responsibility or liability arising out of the application or use of any product or service described herein, except as expressly agreed to in writing by LSI Logic; nor does the purchase, lease, or use of a product or service from LSI Logic convey a license under any patent rights, copyrights, trademark rights, or any other of the intellectual property rights of LSI Logic or of third parties.

Copyright ©2001 by LSI Logic Corporation.
All right reserved.

Order No. S20043
2/01-1M – Printed in USA

LSI LOGIC®