

iNEMO inertial module: always-on 3D accelerometer and 3D gyroscope

Datasheet - preliminary data

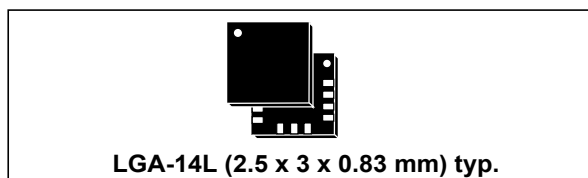

Features

- Power consumption: 0.85 mA in combo normal mode and 1.1 mA in combo high-performance mode up to 1.6 kHz.
- “Always-on” experience with low power consumption for both accelerometer and gyroscope
- Interface flexibility: selectable SPI (3/4-wire) or I²C with the main processor
- Auxiliary SPI (3-wire) to support OIS applications
- EIS/OIS support
- Accelerometer ODR up to 6.66 kHz
- Gyroscope ODR up to 3.33 kHz
- Smart FIFO
- $\pm 2/\pm 4/\pm 8/\pm 16$ g full scale
- $\pm 125/\pm 245/\pm 500/\pm 1000/\pm 2000$ dps full scale
- Analog supply voltage: 1.71 V to 3.6 V
- Independent IOs supply (1.62 V)
- Compact footprint, 2.5 mm x 3 mm x 0.83 mm
- SPI/I²C serial interface data synchronization feature
- Embedded temperature sensor
- ECOPACK[®], RoHS and “Green” compliant

Applications

- EIS and OIS for camera applications
- Collecting sensor data
- Motion tracking and gesture detection
- Pedometer, step detector and step counter
- Significant motion and tilt functions
- Indoor navigation
- IoT and connected devices
- Vibration monitoring and compensation

Description

The LSM6DS3H is a system-in-package featuring a 3D digital accelerometer and a 3D digital gyroscope performing at 1.1 mA (up to 1.6 kHz ODR) in high-performance mode and enabling always-on low-power features for an optimal motion experience for the consumer.

The LSM6DS3H supports main OS requirements, offering real, virtual and batch sensors with 4 kbyte FIFO + flexible 4 kbyte (FIFO or programmable) for dynamic data batching.

The LSM6DS3H gyroscope supports both OIS/EIS applications. The device can be connected to the camera module through a dedicated auxiliary SPI (Mode 3) while flexibility for the primary interface is available (I²C/SPI).

ST’s family of MEMS sensor modules leverages the robust and mature manufacturing processes already used for the production of micromachined accelerometers and gyroscopes.

The various sensing elements are manufactured using specialized micromachining processes, while the IC interfaces are developed using CMOS technology that allows the design of a dedicated circuit which is trimmed to better match the characteristics of the sensing element.

The LSM6DS3H has a full-scale acceleration range of $\pm 2/\pm 4/\pm 8/\pm 16$ g and an angular rate range of $\pm 125/\pm 245/\pm 500/\pm 1000/\pm 2000$ dps.

High robustness to mechanical shock makes the LSM6DS3H the preferred choice of system designers for the creation and manufacturing of reliable products.

The LSM6DS3H is available in a plastic land grid array (LGA) package.

Table 1. Device summary

Part number	Temp. range [°C]	Package	Packing
LSM6DS3H	-40 to +85	LGA-14L (2.5 x 3 x 0.83 mm)	Tray
LSM6DS3HTR	-40 to +85		Tape & Reel

Contents

- 1 Overview 15**
- 2 Embedded low-power features 16**
 - 2.1 Tilt detection 16
- 3 Pin description 17**
 - 3.1 Pin connections 18
- 4 Module specifications 20**
 - 4.1 Mechanical characteristics 20
 - 4.2 Electrical characteristics 22
 - 4.3 Temperature sensor characteristics 23
 - 4.4 Communication interface characteristics 24
 - 4.4.1 SPI - serial peripheral interface 24
 - 4.4.2 I²C - inter-IC control interface 25
 - 4.5 Absolute maximum ratings 26
 - 4.6 Terminology 27
 - 4.6.1 Sensitivity 27
 - 4.6.2 Zero-g and zero-rate level 27
- 5 Functionality 28**
 - 5.1 Operating modes 28
 - 5.2 Gyroscope power modes 28
 - 5.3 Accelerometer power modes 28
 - 5.4 Interface flexibility with auxiliary SPI 28
 - 5.5 FIFO 29
 - 5.5.1 Bypass mode 30
 - 5.5.2 FIFO mode 30
 - 5.5.3 Continuous mode 31
 - 5.5.4 Continuous-to-FIFO mode 31
 - 5.5.5 Bypass-to-Continuous mode 31
 - 5.5.6 FIFO reading procedure 32
 - 5.5.7 Filter block diagrams 32

6	Digital interfaces	34
6.1	I ² C serial interface	34
6.1.1	I ² C operation	35
6.2	SPI bus interface	36
6.2.1	SPI read	37
6.2.2	SPI write	38
6.2.3	SPI read in 3-wire mode	39
7	Application hints	40
7.1	LSM6DS3H electrical connections in Mode 1	40
7.2	LSM6DS3H electrical connections in Mode 2	41
7.3	LSM6DS3H electrical connections in Mode 3	42
8	Register mapping	43
9	Register description	47
9.1	FUNC_CFG_ACCESS (01h)	47
9.2	SENSOR_SYNC_TIME_FRAME (04h)	47
9.3	FIFO_CTRL1 (06h)	47
9.4	FIFO_CTRL2 (07h)	48
9.5	FIFO_CTRL3 (08h)	48
9.6	FIFO_CTRL4 (09h)	49
9.7	FIFO_CTRL5 (0Ah)	50
9.8	ORIENT_CFG_G (0Bh)	51
9.9	INT1_CTRL (0Dh)	52
9.10	INT2_CTRL (0Eh)	53
9.11	WHO_AM_I (0Fh)	53
9.12	CTRL1_XL (10h)	53
9.13	CTRL2_G (11h)	55
9.14	CTRL3_C (12h)	56
9.15	CTRL4_C (13h)	57
9.16	CTRL5_C (14h)	57
9.17	CTRL6_C (15h)	59
9.18	CTRL7_G (16h)	59

9.19	CTRL8_XL (17h)	60
9.20	CTRL9_XL (18h)	60
9.21	CTRL10_C (19h)	61
9.22	MASTER_CONFIG (1Ah)	62
9.23	WAKE_UP_SRC (1Bh)	62
9.24	TAP_SRC (1Ch)	63
9.25	D6D_SRC (1Dh)	64
9.26	STATUS_REG/STATUS_SPIAux (1Eh)	65
9.27	OUT_TEMP_L (20h), OUT_TEMP (21h)	65
9.28	OUTX_L_G (22h)	66
9.29	OUTX_H_G (23h)	66
9.30	OUTY_L_G (24h)	66
9.31	OUTY_H_G (25h)	67
9.32	OUTZ_L_G (26h)	67
9.33	OUTZ_H_G (27h)	68
9.34	OUTX_L_XL (28h)	68
9.35	OUTX_H_XL (29h)	68
9.36	OUTY_L_XL (2Ah)	69
9.37	OUTY_H_XL (2Bh)	69
9.38	OUTZ_L_XL (2Ch)	69
9.39	OUTZ_H_XL (2Dh)	69
9.40	SENSORHUB1_REG (2Eh)	70
9.41	SENSORHUB2_REG (2Fh)	70
9.42	SENSORHUB3_REG (30h)	70
9.43	SENSORHUB4_REG (31h)	70
9.44	SENSORHUB5_REG (32h)	71
9.45	SENSORHUB6_REG (33h)	71
9.46	SENSORHUB7_REG (34h)	71
9.47	SENSORHUB8_REG(35h)	71
9.48	SENSORHUB9_REG (36h)	72
9.49	SENSORHUB10_REG (37h)	72
9.50	SENSORHUB11_REG (38h)	72
9.51	SENSORHUB12_REG(39h)	72

9.52	FIFO_STATUS1 (3Ah)	73
9.53	FIFO_STATUS2 (3Bh)	73
9.54	FIFO_STATUS3 (3Ch)	73
9.55	FIFO_STATUS4 (3Dh)	74
9.56	FIFO_DATA_OUT_L (3Eh)	74
9.57	FIFO_DATA_OUT_H (3Fh)	75
9.58	TIMESTAMP0_REG (40h)	75
9.59	TIMESTAMP1_REG (41h)	75
9.60	TIMESTAMP2_REG (42h)	75
9.61	STEP_TIMESTAMP_L (49h)	76
9.62	STEP_TIMESTAMP_H (4Ah)	76
9.63	STEP_COUNTER_L (4Bh)	76
9.64	STEP_COUNTER_H (4Ch)	76
9.65	SENSORHUB13_REG (4Dh)	77
9.66	SENSORHUB14_REG (4Eh)	77
9.67	SENSORHUB15_REG (4Fh)	77
9.68	SENSORHUB16_REG (50h)	77
9.69	SENSORHUB17_REG (51h)	78
9.70	SENSORHUB18_REG (52h)	78
9.71	FUNC_SRC (53h)	78
9.72	TAP_CFG (58h)	79
9.73	TAP_THS_6D (59h)	79
9.74	INT_DUR2 (5Ah)	80
9.75	WAKE_UP_THS (5Bh)	80
9.76	WAKE_UP_DUR (5Ch)	81
9.77	FREE_FALL (5Dh)	81
9.78	MD1_CFG (5Eh)	82
9.79	MD2_CFG (5Fh)	83
9.80	OUT_MAG_RAW_X_L (66h)	83
9.81	OUT_MAG_RAW_X_H (67h)	83
9.82	OUT_MAG_RAW_Y_L (68h)	84
9.83	OUT_MAG_RAW_Y_H (69h)	84
9.84	OUT_MAG_RAW_Z_L (6Ah)	84

9.85	OUT_MAG_RAW_Z_H (6Bh)	84
9.86	CTRL_SPIAux (70h)	85
10	Embedded functions register mapping	86
11	Embedded functions registers description	88
11.1	SLV0_ADD (02h)	88
11.2	SLV0_SUBADD (03h)	88
11.3	SLAVE0_CONFIG (04h)	88
11.4	SLV1_ADD (05h)	89
11.5	SLV1_SUBADD (06h)	89
11.6	SLAVE1_CONFIG (07h)	90
11.7	SLV2_ADD (08h)	90
11.8	SLV2_SUBADD (09h)	90
11.9	SLAVE2_CONFIG (0Ah)	91
11.10	SLV3_ADD (0Bh)	91
11.11	SLV3_SUBADD (0Ch)	91
11.12	SLAVE3_CONFIG (0Dh)	92
11.13	DATAWRITE_SRC_MODE_SUB_SLV0 (0Eh)	92
11.14	SM_THS (13h)	92
11.15	STEP_COUNT_DELTA (15h)	93
11.16	MAG_SI_XX (24h)	93
11.17	MAG_SI_XY (25h)	93
11.18	MAG_SI_XZ (26h)	93
11.19	MAG_SI_YX (27h)	94
11.20	MAG_SI_YY (28h)	94
11.21	MAG_SI_YZ (29h)	94
11.22	MAG_SI_ZX (2Ah)	94
11.23	MAG_SI_ZY (2Bh)	95
11.24	MAG_SI_ZZ (2Ch)	95
11.25	MAG_OFFX_L (2Dh)	95
11.26	MAG_OFFX_H (2Eh)	95
11.27	MAG_OFFY_L (2Fh)	96
11.28	MAG_OFFY_H (30h)	96

11.29	MAG_OFFZ_L (31h)	96
11.30	MAG_OFFZ_H (32h)	96
12	Soldering information	97
13	Package information	98
13.1	LGA-14 package information	98
14	Revision history	99

List of tables

Table 1.	Device summary	1
Table 2.	Pin description	19
Table 3.	Mechanical characteristics	20
Table 4.	Electrical characteristics	22
Table 5.	Temperature sensor characteristics	23
Table 6.	SPI slave timing values	24
Table 7.	I ² C slave timing values	25
Table 8.	Absolute maximum ratings	26
Table 9.	Serial interface pin description	34
Table 10.	I ² C terminology	34
Table 11.	SAD+Read/Write patterns	35
Table 12.	Transfer when master is writing one byte to slave	35
Table 13.	Transfer when master is writing multiple bytes to slave	35
Table 14.	Transfer when master is receiving (reading) one byte of data from slave	36
Table 15.	Transfer when master is receiving (reading) multiple bytes of data from slave	36
Table 16.	Registers address map	43
Table 17.	FUNC_CFG_ACCESS register	47
Table 18.	FUNC_CFG_ACCESS register description	47
Table 19.	SENSOR_SYNC_TIME_FRAME register	47
Table 20.	ISENSOR_SYNC_TIME_FRAME register description	47
Table 21.	FIFO_CTRL1 register	47
Table 22.	FIFO_CTRL1 register description	47
Table 23.	FIFO_CTRL2 register	48
Table 24.	FIFO_CTRL2 register description	48
Table 25.	FIFO_CTRL3 register	48
Table 26.	FIFO_CTRL3 register description	48
Table 27.	Gyro FIFO decimation setting	49
Table 28.	Accelerometer FIFO decimation setting	49
Table 29.	FIFO_CTRL4 register	49
Table 30.	FIFO_CTRL4 register description	49
Table 31.	Fourth FIFO data set decimation setting	50
Table 32.	Third FIFO data set decimation setting	50
Table 33.	FIFO_CTRL5 register	50
Table 34.	FIFO_CTRL5 register description	50
Table 35.	FIFO ODR selection	51
Table 36.	FIFO mode selection	51
Table 37.	ORIENT_CFG_G register	51
Table 38.	ORIENT_CFG_G register description	52
Table 39.	Settings for orientation of axes	52
Table 40.	INT1_CTRL register	52
Table 41.	INT1_CTRL register description	52
Table 42.	INT2_CTRL register	53
Table 43.	INT2_CTRL register description	53
Table 44.	WHO_AM_I register	53
Table 45.	CTRL1_XL register	53
Table 46.	CTRL1_XL register description	54
Table 47.	Accelerometer ODR register setting	54
Table 48.	BW and ODR (high-performance mode)	54

Table 49.	CTRL2_G register	55
Table 50.	CTRL2_G register description	55
Table 51.	Gyroscope ODR configuration setting	55
Table 52.	CTRL3_C register	56
Table 53.	CTRL3_C register description	56
Table 54.	CTRL4_C register	57
Table 55.	CTRL4_C register description	57
Table 56.	CTRL5_C register	57
Table 57.	CTRL5_C register description	58
Table 58.	Output registers rounding pattern	58
Table 59.	Angular rate sensor self-test mode selection	58
Table 60.	Linear acceleration sensor self-test mode selection	58
Table 61.	CTRL6_C register	59
Table 62.	CTRL6_C register description	59
Table 63.	CTRL7_G register	59
Table 64.	CTRL7_G register description	59
Table 65.	Gyroscope high-pass filter mode configuration	60
Table 66.	CTRL8_XL register	60
Table 67.	CTRL8_XL register description	60
Table 68.	Accelerometer slope and high-pass filter selection and cutoff frequency	60
Table 69.	CTRL9_XL register	60
Table 70.	CTRL9_XL register description	61
Table 71.	CTRL10_C register	61
Table 72.	CTRL10_C register description	61
Table 73.	MASTER_CONFIG register	62
Table 74.	MASTER_CONFIG register description	62
Table 75.	WAKE_UP_SRC register	62
Table 76.	WAKE_UP_SRC register description	63
Table 77.	TAP_SRC register	63
Table 78.	TAP_SRC register description	63
Table 79.	D6D_SRC register	64
Table 80.	D6D_SRC register description	64
Table 81.	STATUS_REG register	65
Table 82.	STATUS_REG register description	65
Table 83.	STATUS_SPIAux register	65
Table 84.	STATUS_SPIAux description	65
Table 85.	OUT_TEMP_L register	65
Table 86.	OUT_TEMP_H register	65
Table 87.	OUT_TEMP register description	65
Table 88.	OUTX_L_G register	66
Table 89.	OUTX_L_G register description	66
Table 90.	OUTX_H_G register	66
Table 91.	OUTX_H_G register description	66
Table 92.	OUTY_L_G register	67
Table 93.	OUTY_L_G register description	67
Table 94.	OUTY_H_G register	67
Table 95.	OUTY_H_G register description	67
Table 96.	OUTZ_L_G register	67
Table 97.	OUTZ_L_G register description	67
Table 98.	OUTZ_H_G register	68
Table 99.	OUTZ_H_G register description	68
Table 100.	OUTX_L_XL register	68

Table 101.	OUTX_L_XL register description	68
Table 102.	OUTX_H_XL register	68
Table 103.	OUTX_H_XL register description	68
Table 104.	OUTY_L_XL register	69
Table 105.	OUTY_L_XL register description	69
Table 106.	OUTY_H_G register	69
Table 107.	OUTY_H_G register description	69
Table 108.	OUTZ_L_XL register	69
Table 109.	OUTZ_L_XL register description	69
Table 110.	OUTZ_H_XL register	69
Table 111.	OUTZ_H_XL register description	69
Table 112.	SENSORHUB1_REG register	70
Table 113.	SENSORHUB1_REG register description	70
Table 114.	SENSORHUB2_REG register	70
Table 115.	SENSORHUB2_REG register description	70
Table 116.	SENSORHUB3_REG register	70
Table 117.	SENSORHUB3_REG register description	70
Table 118.	SENSORHUB4_REG register	70
Table 119.	SENSORHUB4_REG register description	70
Table 120.	SENSORHUB5_REG register	71
Table 121.	SENSORHUB5_REG register description	71
Table 122.	SENSORHUB6_REG register	71
Table 123.	SENSORHUB6_REG register description	71
Table 124.	SENSORHUB7_REG register	71
Table 125.	SENSORHUB7_REG register description	71
Table 126.	SENSORHUB8_REG register	71
Table 127.	SENSORHUB8_REG register description	71
Table 128.	SENSORHUB9_REG register	72
Table 129.	SENSORHUB9_REG register description	72
Table 130.	SENSORHUB10_REG register	72
Table 131.	SENSORHUB10_REG register description	72
Table 132.	SENSORHUB11_REG register	72
Table 133.	SENSORHUB11_REG register description	72
Table 134.	SENSORHUB12_REG register	72
Table 135.	SENSORHUB12_REG register description	72
Table 136.	FIFO_STATUS1 register	73
Table 137.	FIFO_STATUS1 register description	73
Table 138.	FIFO_STATUS2 register	73
Table 139.	FIFO_STATUS2 register description	73
Table 140.	FIFO_STATUS3 register	73
Table 141.	FIFO_STATUS3 register description	74
Table 142.	FIFO_STATUS4 register	74
Table 143.	FIFO_STATUS4 register description	74
Table 144.	FIFO_DATA_OUT_L register	74
Table 145.	FIFO_DATA_OUT_L register description	74
Table 146.	FIFO_DATA_OUT_H register	75
Table 147.	FIFO_DATA_OUT_H register description	75
Table 148.	TIMESTAMP0_REG register	75
Table 149.	TIMESTAMP0_REG register description	75
Table 150.	TIMESTAMP1_REG register	75
Table 151.	TIMESTAMP1_REG register description	75
Table 152.	TIMESTAMP2_REG register	75

Table 153.	TIMESTAMP2_REG register description	75
Table 154.	STEP_TIMESTAMP_L register	76
Table 155.	STEP_TIMESTAMP_L register description	76
Table 156.	STEP_TIMESTAMP_H register	76
Table 157.	STEP_TIMESTAMP_H register description	76
Table 158.	STEP_COUNTER_L register	76
Table 159.	STEP_COUNTER_L register description	76
Table 160.	STEP_COUNTER_H register	76
Table 161.	STEP_COUNTER_H register description	76
Table 162.	SENSORHUB13_REG register	77
Table 163.	SENSORHUB13_REG register description	77
Table 164.	SENSORHUB14_REG register	77
Table 165.	SENSORHUB14_REG register description	77
Table 166.	SENSORHUB15_REG register	77
Table 167.	SENSORHUB15_REG register description	77
Table 168.	SENSORHUB16_REG register	77
Table 169.	SENSORHUB16_REG register description	77
Table 170.	SENSORHUB17_REG register	78
Table 171.	SENSORHUB17_REG register description	78
Table 172.	SENSORHUB18_REG register	78
Table 173.	SENSORHUB18_REG register description	78
Table 174.	FUNC_SRC register	78
Table 175.	FUNC_SRC register description	78
Table 176.	TAP_CFG register	79
Table 177.	TAP_CFG register description	79
Table 178.	TAP_THS_6D register	79
Table 179.	TAP_THS_6D register description	79
Table 180.	Threshold for D4D/D6D function	80
Table 181.	INT_DUR2 register	80
Table 182.	INT_DUR2 register description	80
Table 183.	WAKE_UP_THS register	80
Table 184.	WAKE_UP_THS register description	81
Table 185.	WAKE_UP_DUR register	81
Table 186.	WAKE_UP_DUR register description	81
Table 187.	FREE_FALL register	81
Table 188.	FREE_FALL register description	81
Table 189.	Threshold for free-fall function	82
Table 190.	MD1_CFG register	82
Table 191.	MD1_CFG register description	82
Table 192.	MD2_CFG register	83
Table 193.	MD2_CFG register description	83
Table 194.	OUT_MAG_RAW_X_L register	83
Table 195.	OUT_MAG_RAW_X_L register description	83
Table 196.	OUT_MAG_RAW_X_H register	83
Table 197.	OUT_MAG_RAW_X_H register description	84
Table 198.	OUT_MAG_RAW_Y_L register	84
Table 199.	OUT_MAG_RAW_Y_L register description	84
Table 200.	OUT_MAG_RAW_Y_H register	84
Table 201.	OUT_MAG_RAW_Y_H register description	84
Table 202.	OUT_MAG_RAW_Z_L register	84
Table 203.	OUT_MAG_RAW_Z_L register description	84
Table 204.	OUT_MAG_RAW_Z_H register	84

Table 205.	OUT_MAG_RAW_Z_H register description	84
Table 206.	CTRL_SPIAux register	85
Table 207.	CTRL_SPIAux register description	85
Table 208.	Registers address map - embedded functions	86
Table 209.	SLV0_ADD register	88
Table 210.	SLV0_ADD register description	88
Table 211.	SLV0_SUBADD register	88
Table 212.	SLV0_SUBADD register description	88
Table 213.	SLAVE0_CONFIG register	88
Table 214.	SLAVE0_CONFIG register description	89
Table 215.	SLV1_ADD register	89
Table 216.	SLV1_ADD register description	89
Table 217.	SLV1_SUBADD register	89
Table 218.	SLV1_SUBADD register description	89
Table 219.	SLAVE1_CONFIG register	90
Table 220.	SLAVE1_CONFIG register description	90
Table 221.	SLV2_ADD register	90
Table 222.	SLV2_ADD register description	90
Table 223.	SLV2_SUBADD register	90
Table 224.	SLV2_SUBADD register description	90
Table 225.	SLAVE2_CONFIG register	91
Table 226.	SLAVE2_CONFIG register description	91
Table 227.	SLV3_ADD register	91
Table 228.	SLV3_ADD register description	91
Table 229.	SLV3_SUBADD register	91
Table 230.	SLV3_SUBADD register description	91
Table 231.	SLAVE3_CONFIG register	92
Table 232.	SLAVE3_CONFIG register description	92
Table 233.	DATAWRITE_SRC_MODE_SUB_SLV0 register	92
Table 234.	DATAWRITE_SRC_MODE_SUB_SLV0 register description	92
Table 235.	SM_THS register	92
Table 236.	SM_THS register description	92
Table 237.	STEP_COUNT_DELTA register	93
Table 238.	STEP_COUNT_DELTA register description	93
Table 239.	MAG_SI_XX register	93
Table 240.	MAG_SI_XX register description	93
Table 241.	MAG_SI_XY register	93
Table 242.	MAG_SI_XY register description	93
Table 243.	MAG_SI_XZ register	93
Table 244.	MAG_SI_XZ register description	93
Table 245.	MAG_SI_YX register	94
Table 246.	MAG_SI_YX register description	94
Table 247.	MAG_SI_YY register	94
Table 248.	MAG_SI_YY register description	94
Table 249.	MAG_SI_YZ register	94
Table 250.	MAG_SI_YZ register description	94
Table 251.	MAG_SI_ZX register	94
Table 252.	MAG_SI_ZX register description	94
Table 253.	MAG_SI_ZY register	95
Table 254.	MAG_SI_ZY register description	95
Table 255.	MAG_SI_ZZ register	95
Table 256.	MAG_SI_ZZ register description	95

Table 257.	MAG_OFFX_L register	95
Table 258.	MAG_OFFX_L register description	95
Table 259.	MAG_OFFX_H register	95
Table 260.	MAG_OFFX_L register description	95
Table 261.	MAG_OFFY_L register	96
Table 262.	MAG_OFFY_L register description	96
Table 263.	MAG_OFFY_H register	96
Table 264.	MAG_OFFY_L register description	96
Table 265.	MAG_OFFZ_L register	96
Table 266.	MAG_OFFZ_L register description	96
Table 267.	MAG_OFFZ_H register	96
Table 268.	MAG_OFFX_L register description	96
Table 269.	Document revision history	99

List of figures

Figure 1.	Pin connections	17
Figure 2.	LSM6DS3H connection modes.	18
Figure 3.	SPI slave timing diagram	24
Figure 4.	I ² C slave timing diagram	25
Figure 5.	Mode 3 interface configuration (OIS applications)	29
Figure 6.	Accelerometer chain	32
Figure 7.	Accelerometer composite filter	33
Figure 8.	Gyroscope chain	33
Figure 9.	Read and write protocol	36
Figure 10.	SPI read protocol	37
Figure 11.	Multiple byte SPI read protocol (2-byte example).	38
Figure 12.	SPI write protocol	38
Figure 13.	Multiple byte SPI write protocol (2-byte example).	38
Figure 14.	SPI read protocol in 3-wire mode	39
Figure 15.	LSM6DS3H electrical connections in Mode 1.	40
Figure 16.	LSM6DS3H electrical connections in Mode 2.	41
Figure 17.	LSM6DS3H electrical connections in Mode 3.	42
Figure 18.	LGA-14 2.5x3x0.86 14L package outline and mechanical data	98



1 Overview

The LSM6DS3H is a system-in-package featuring a high-performance 3-axis digital accelerometer and 3-axis digital gyroscope.

The integrated power-efficient modes are able to reduce the power consumption down to 1.1 mA in high-performance mode, combining always-on low-power features with superior sensing precision for an optimal motion experience for the consumer thanks to ultra-low noise performance for both the gyroscope and accelerometer.

The LSM6DS3H delivers best-in-class motion sensing that can detect orientation and gestures in order to empower application developers and consumers with features and capabilities that are more sophisticated than simply orienting their devices to portrait and landscape mode.

The event-detection interrupts enable efficient and reliable motion tracking and contextual awareness, implementing hardware recognition of free-fall events, 6D orientation, tap and double-tap sensing, activity or inactivity, and wakeup events.

The LSM6DS3H supports main OS requirements, offering real, virtual and batch mode sensors. In addition, the LSM6DS3H can efficiently run the sensor-related features specified in Android, saving power and enabling faster reaction time. In particular, the LSM6DS3H has been designed to implement hardware features such as significant motion, tilt, pedometer functions, time stamping and to support the data acquisition of an external magnetometer with ironing correction (hard, soft).

The LSM6DS3H offers hardware flexibility to connect the pins with different mode connections to external sensors to expand functionalities such as adding a sensor hub, auxiliary SPI, etc. The application processor connection is supported by both SPI and I²C interfaces for complete interface flexibility.

Up to 8 kbyte of FIFO [4 kbyte FIFO + flexible 4 kbyte (FIFO or programmable)] with dynamic allocation of significant data (i.e. external sensors, time stamp, etc.) allows overall power saving of the system.

Like the entire portfolio of MEMS sensor modules, the LSM6DS3H leverages the robust and mature in-house manufacturing processes already used for the production of micromachined accelerometers and gyroscopes. The various sensing elements are manufactured using specialized micromachining processes, while the IC interfaces are developed using CMOS technology that allows the design of a dedicated circuit which is trimmed to better match the characteristics of the sensing element.

The LSM6DS3H is available in a small plastic land grid array (LGA) package of 2.5 x 3.0 x 0.83 mm to address ultra-compact solutions.

2 Embedded low-power features

The LSM6DS3H has been designed to be fully compliant with Android, featuring the following on-chip functions:

- 8 kbyte data buffering
 - 4 kbyte FIFO + flexible 4 kbyte (FIFO or programmable)
 - 100% efficiency with flexible configurations and partitioning
 - possibility to store time stamp
- Event-detection interrupts (fully configurable):
 - free-fall
 - wakeup
 - 6D orientation
 - tap and double-tap sensing
 - activity / inactivity recognition
- Specific IP blocks with negligible power consumption and high-performance:
 - pedometer functions: step detector and step counters
 - tilt (Android compliant, refer to [Section 2.1: Tilt detection](#) for additional info)
 - significant motion (Android compliant)
- Sensor hub
 - up to 6 total sensors: 2 internal (accelerometer and gyroscope) and 4 external sensors
- Data rate synchronization with external trigger for reduced sensor access and enhanced fusion

2.1 Tilt detection

The tilt function helps to detect activity change and has been implemented in hardware using only the accelerometer to achieve both the targets of ultra-low power consumption and robustness during the short duration of dynamic accelerations.

It is based on a trigger of an event each time the device's tilt changes by an angle greater than 35 degrees from the start position.

The tilt function can be used with different scenarios, for example:

- a) Trigger when phone is in a front pants pocket and the user goes from sitting to standing or standing to sitting;
- b) Doesn't trigger when phone is in a front pants pocket and the user is walking, running or going upstairs.

3 Pin description

Figure 1. Pin connections

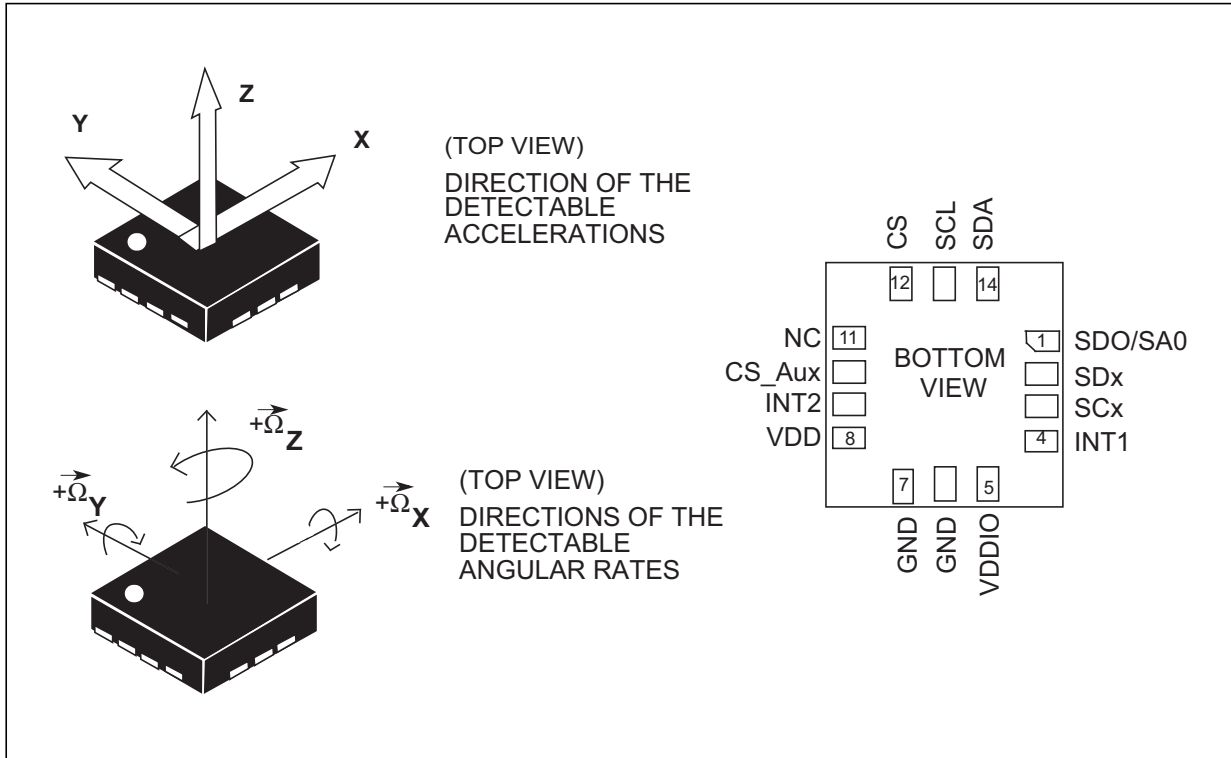

3.1 Pin connections

LSM6DS3H offers the flexibility to connect the pins in order to have three different mode connections and functionalities. In detail:

- **Mode 1:** I²C slave interface or SPI (3- and 4-wire) serial interface is available;
- **Mode 2:** I²C slave interface or SPI (3- and 4-wire) serial interface and I²C interface master for external sensors connections are available;
- **Mode 3^(a):** I²C slave interface or SPI (3- and 4-wire) serial interface is available for the application processor interface while an auxiliary SPI (3-wire) serial interface for external sensor connections (i.e. camera module) is available.

Figure 2. LSM6DS3H connection modes

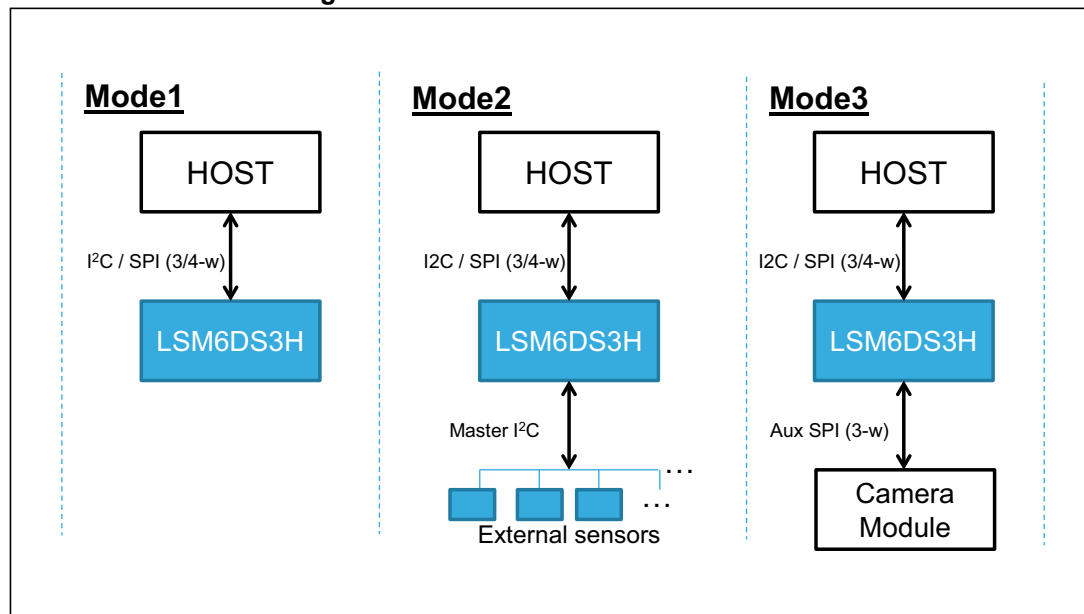

In the following table each mode is described for the pin connection and function.

a. In the primary SPI connection, the gyroscope output data is available in registers 22h to 27h with user-selected FS and ODR. In the auxiliary SPI connection, gyroscope output data is available in registers 22h to 27h @ 3.3 kHz and FS = 250 dps

Table 2. Pin description

Pin#	Name	Mode 1 function	Mode 2 function	Mode 3 function
1	SDO/SA0	SPI 4-wire interface serial data output (SDO) I ² C least significant bit of the device address (SA0)	SPI 4-wire interface serial data output (SDO) I ² C least significant bit of the device address (SA0)	SPI 4-wire interface serial data output (SDO) I ² C least significant bit of the device address (SA0)
2	SDx	Connect to VDDIO or GND	I ² C serial data master (MSDA)	Auxiliary SPI 3-wire interface serial data input (SDI_Aux) and serial data output (SDO_Aux)
3	SCx	Connect to VDDIO or GND	I ² C serial clock master (MSCL)	Auxiliary SPI 3-wire interface serial port clock (SPC_Aux)
4	INT1	Programmable interrupt 1		
5	VDDIO ⁽¹⁾	Power supply for I/O pins		
6	GND	0 V supply		
7	GND	0 V supply		
8	VDD ⁽²⁾	Power supply		
9	INT2	Programmable interrupt 2 (INT2)/ Data enable (DEN)	Programmable interrupt 2 (INT2)/ Data enable (DEN)/ I ² C master external synchronization signal (MDRDY)	Programmable interrupt 2 (INT2)/ Data enable (DEN)
10	CS_Aux	Leave unconnected	Leave unconnected	Auxiliary SPI 3-wire interface enable
11	NC	Leave unconnected		
12	CS	I ² C/SPI mode selection (1: SPI idle mode / I ² C communication enabled; 0: SPI communication mode / I ² C disabled)	I ² C/SPI mode selection (1: SPI idle mode / I ² C communication enabled; 0: SPI communication mode / I ² C disabled)	I ² C/SPI mode selection (1: SPI idle mode / I ² C communication enabled; 0: SPI communication mode / I ² C disabled)
13	SCL	I ² C serial clock (SCL) SPI serial port clock (SPC)	I ² C serial clock (SCL) SPI serial port clock (SPC)	I ² C serial clock (SCL) SPI serial port clock (SPC)
14	SDA	I ² C serial data (SDA) SPI serial data input (SDI) 3-wire interface serial data output (SDO)	I ² C serial data (SDA) SPI serial data input (SDI) 3-wire interface serial data output (SDO)	I ² C serial data (SDA) SPI serial data input (SDI) 3-wire interface serial data output (SDO)

1. Recommended 100 nF filter capacitor.
2. Recommended 100 nF capacitor.

4 Module specifications

4.1 Mechanical characteristics

@ Vdd = 1.8 V, T = 25 °C unless otherwise noted.

Table 3. Mechanical characteristics

Symbol	Parameter	Test conditions	Min.	Typ. ⁽¹⁾	Max.	Unit
LA_FS	Linear acceleration measurement range			±2		g
				±4		
				±8		
				±16		
G_FS	Angular rate measurement range			±125		dps
				±245		
				±500		
				±1000		
				±2000		
LA_So	Linear acceleration sensitivity ⁽²⁾	FS = ±2		0.061		mg/LSB
		FS = ±4		0.122		
		FS = ±8		0.244		
		FS = ±16		0.488		
G_So	Angular rate sensitivity ⁽³⁾	FS = ±125		4.375		mdps/LSB
		FS = ±245		8.75		
		FS = ±500		17.50		
		FS = ±1000		35		
		FS = ±2000		70		
LA_SoDr	Linear acceleration sensitivity change vs. temperature	from -40° to +85° delta from T=25°		±1		%
G_SoDr	Angular rate sensitivity change vs. temperature	from -40° to +85° delta from T=25°		±1.5		%
LA_TyOff	Linear acceleration typical zero-g level offset accuracy ⁽⁴⁾			±40		mg
G_TyOff	Angular rate typical zero-rate level ⁽⁵⁾			±10		dps
LA_OffDr	Linear acceleration zero-g level change vs. temperature			±0.5		mg/°C
G_OffDr	Angular rate typical zero-rate level change vs. temperature			±0.05		dps/°C
Rn	Rate noise density			6		mdps/√Hz
An	Acceleration noise density	FS= ±2 g ODR = 104 Hz		90		µg/√Hz

Table 3. Mechanical characteristics (continued)

Symbol	Parameter	Test conditions	Min.	Typ. ⁽¹⁾	Max.	Unit
LA_ODR	Linear acceleration output data rate			13		Hz
				26		
				52		
				104		
				208		
				416		
				833		
				1666		
				3332		
				6664		
G_ODR	Angular rate output data rate			13		Hz
				26		
				52		
				104		
				208		
				416		
				833		
				1666		
				3332 ⁽⁶⁾		
				Top		

1. Typical specifications are not guaranteed.
2. Linear acceleration sensitivity after factory calibration test and trimming.
3. Angular rate sensitivity after factory calibration test and trimming.
4. Values after soldering.
5. Values after soldering.
6. To enable this ODR, refer to [CTRL4_C \(13h\)](#).

4.2 Electrical characteristics

@ Vdd = 1.8 V, T = 25 °C unless otherwise noted.

Table 4. Electrical characteristics

Symbol	Parameter	Test conditions	Min.	Typ. ⁽¹⁾	Max.	Unit
Vdd	Supply voltage		1.71	1.8	3.6	V
Vdd_IO	Power supply for I/O		1.62		Vdd + 0.1	V
IddHP	Gyroscope and accelerometer in high-performance mode	up to ODR = 1.6 kHz		1.1		mA
IddNM	Gyroscope and accelerometer in normal mode	ODR = 208 Hz		0.85		mA
IddLP	Gyroscope and accelerometer in low-power mode	ODR = 13 Hz		0.4		mA
LA_IddHP	Accelerometer current consumption in high-performance mode	up to ODR = 1.6 kHz		240		μA
LA_IddNM	Accelerometer current consumption in normal mode	ODR = 104 Hz		60		μA
LA_IddLM	Accelerometer current consumption in low-power mode	ODR = 13 Hz		10		μA
IddPD	Gyroscope and accelerometer in power down			6		μA
Top	Operating temperature range		-40		+85	°C

1. Typical specifications are not guaranteed.

For details related to the LSM6DS3H operating modes, refer to [5.2: Gyroscope power modes](#) and [5.3: Accelerometer power modes](#).

4.3 Temperature sensor characteristics

@ V_{dd} = 1.8 V, T = 25 °C unless otherwise noted.

Table 5. Temperature sensor characteristics

Symbol	Parameter	Test condition	Min.	Typ. ⁽¹⁾	Max.	Unit
TODR	Temperature refresh rate			52		Hz
Toff	Temperature offset ⁽²⁾		-15		+15	°C
TSen	Temperature sensitivity			16		LSB/°C
TST	Temperature stabilization time ⁽³⁾				500	µs
T_ADC_res	Temperature ADC resolution			12		bit
Top	Operating temperature range		-40		+85	°C

1. Typical specifications are not guaranteed.
2. The output of the temperature sensor is 0 LSB (typ.) at 25 °C.
3. Time from power ON bit to valid data based on characterization data.

4.4 Communication interface characteristics

4.4.1 SPI - serial peripheral interface

Subject to general operating conditions for Vdd and Top.

Table 6. SPI slave timing values

Symbol	Parameter	Value ⁽¹⁾		Unit
		Min	Max	
$t_{c(SPC)}$	SPI clock cycle	100		ns
$f_{c(SPC)}$	SPI clock frequency		10	MHz
$t_{su(CS)}$	CS setup time	5		ns
$t_{h(CS)}$	CS hold time	20		
$t_{su(SI)}$	SDI input setup time	5		
$t_{h(SI)}$	SDI input hold time	15		
$t_{v(SO)}$	SDO valid output time		50	
$t_{h(SO)}$	SDO output hold time	5		
$t_{dis(SO)}$	SDO output disable time		50	

1. Values are guaranteed at 10 MHz clock frequency for SPI with both 4 and 3 wires, based on characterization results, not tested in production

Figure 3. SPI slave timing diagram

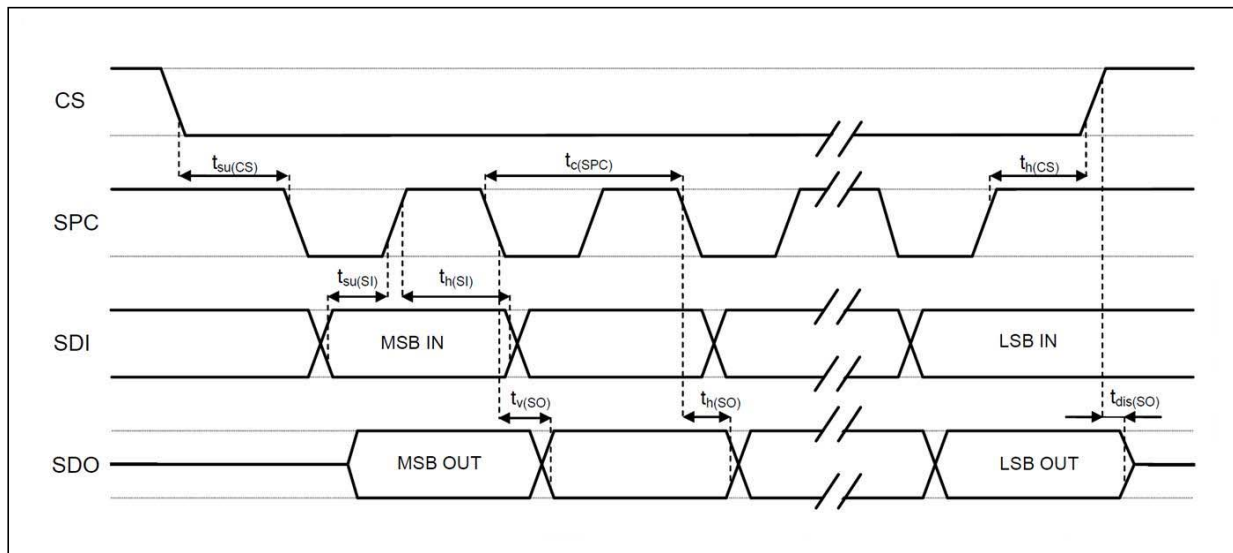

Note: Measurement points are done at $0.2 \cdot V_{dd_IO}$ and $0.8 \cdot V_{dd_IO}$, for both input and output ports.

4.4.2 I²C - inter-IC control interface

Subject to general operating conditions for Vdd and Top.

Table 7. I²C slave timing values

Symbol	Parameter	I ² C Standard mode ⁽¹⁾		I ² C Fast mode ⁽¹⁾		Unit
		Min	Max	Min	Max	
f _(SCL)	SCL clock frequency	0	100	0	400	kHz
t _{w(SCLL)}	SCL clock low time	4.7		1.3		μs
t _{w(SCLH)}	SCL clock high time	4.0		0.6		
t _{su(SDA)}	SDA setup time	250		100		ns
t _{h(SDA)}	SDA data hold time	0	3.45	0	0.9	μs
t _{h(ST)}	START condition hold time	4		0.6		μs
t _{su(SR)}	Repeated START condition setup time	4.7		0.6		
t _{su(SP)}	STOP condition setup time	4		0.6		
t _{w(SP:SR)}	Bus free time between STOP and START condition	4.7		1.3		

1. Data based on standard I²C protocol requirement, not tested in production.

Figure 4. I²C slave timing diagram

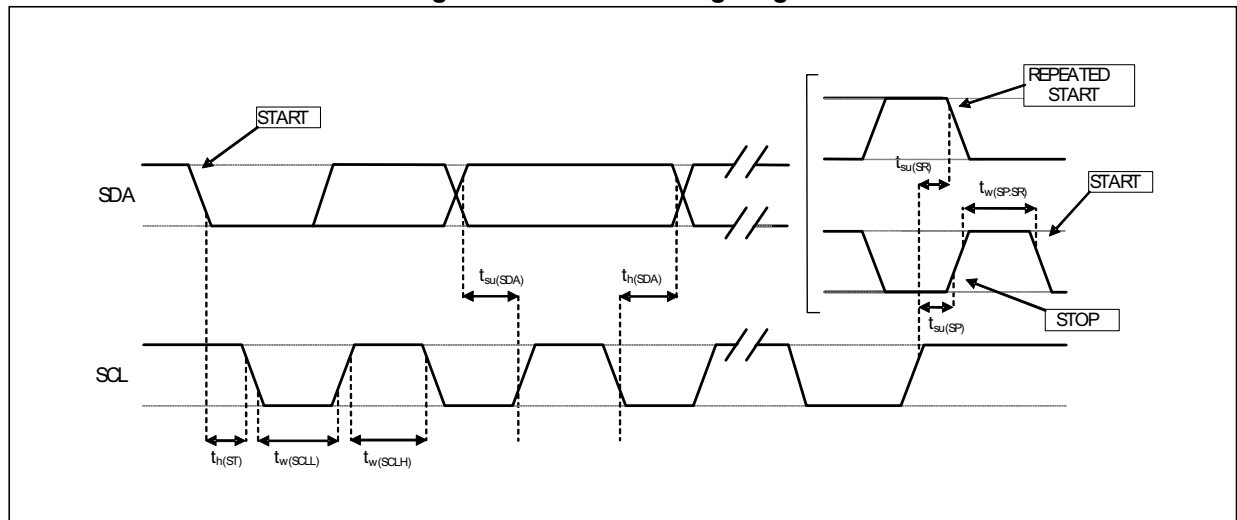

Note: Measurement points are done at 0.2·Vdd_{IO} and 0.8·Vdd_{IO}, for both ports.

4.5 Absolute maximum ratings

Stresses above those listed as “Absolute maximum ratings” may cause permanent damage to the device. This is a stress rating only and functional operation of the device under these conditions is not implied. Exposure to maximum rating conditions for extended periods may affect device reliability.

Table 8. Absolute maximum ratings

Symbol	Ratings	Maximum value	Unit
Vdd	Supply voltage	-0.3 to 4.8	V
T _{STG}	Storage temperature range	-40 to +125	°C
Sg	Acceleration g for 0.1 ms	10,000	g
ESD	Electrostatic discharge protection (HBM)	2	kV
V _{in}	Input voltage on any control pin (including CS, SCL/SPC, SDA/SDI/SDO, SDO/SA0)	0.3 to Vdd_IO +0.3	V

Note: Supply voltage on any pin should never exceed 4.8 V.



This device is sensitive to mechanical shock, improper handling can cause permanent damage to the part.



This device is sensitive to electrostatic discharge (ESD), improper handling can cause permanent damage to the part.

4.6 Terminology

4.6.1 Sensitivity

Linear acceleration sensitivity can be determined, for example, by applying 1 *g* acceleration to the device. Because the sensor can measure DC accelerations, this can be done easily by pointing the selected axis towards the ground, noting the output value, rotating the sensor 180 degrees (pointing towards the sky) and noting the output value again. By doing so, ± 1 *g* acceleration is applied to the sensor. Subtracting the larger output value from the smaller one, and dividing the result by 2, leads to the actual sensitivity of the sensor. This value changes very little over temperature and over time. The sensitivity tolerance describes the range of sensitivities of a large number of sensors.

An angular rate gyroscope is device that produces a positive-going digital output for counterclockwise rotation around the axis considered. Sensitivity describes the gain of the sensor and can be determined by applying a defined angular velocity to it. This value changes very little over temperature and time.

4.6.2 Zero-g and zero-rate level

Linear acceleration zero-*g* level offset (TyOff) describes the deviation of an actual output signal from the ideal output signal if no acceleration is present. A sensor in a steady state on a horizontal surface will measure 0 *g* on both the X-axis and Y-axis, whereas the Z-axis will measure 1 *g*. Ideally, the output is in the middle of the dynamic range of the sensor (content of OUT registers 00h, data expressed as 2's complement number). A deviation from the ideal value in this case is called zero-*g* offset.

Offset is to some extent a result of stress to MEMS sensor and therefore the offset can slightly change after mounting the sensor onto a printed circuit board or exposing it to extensive mechanical stress. Offset changes little over temperature, see "Linear acceleration zero-*g* level change vs. temperature" in [Table 3](#). The zero-*g* level tolerance (TyOff) describes the standard deviation of the range of zero-*g* levels of a group of sensors.

Zero-rate level describes the actual output signal if there is no angular rate present. The zero-rate level of precise MEMS sensors is, to some extent, a result of stress to the sensor and therefore the zero-rate level can slightly change after mounting the sensor onto a printed circuit board or after exposing it to extensive mechanical stress. This value changes very little over temperature and time.

5 Functionality

5.1 Operating modes

The LSM6DS3H has three operating modes available:

- only accelerometer active and gyroscope in power-down
- only gyroscope active and accelerometer in power-down
- both accelerometer and gyroscope sensors active with independent ODR

The accelerometer is activated from power down by writing ODR_XL[3:0] in [CTRL1_XL \(10h\)](#) while the gyroscope is activated from power-down by writing ODR_G[3:0] in [CTRL2_G \(11h\)](#). For combo mode the ODRs are totally independent.

5.2 Gyroscope power modes

In the LSM6DS3H, the gyroscope can be configured in four different operating modes: power-down, low-power, normal mode and high-performance mode. The operating mode selected depends on the value of the G_HM_MODE bit in [CTRL7_G \(16h\)](#). If G_HM_MODE is set to '0', high-performance mode is valid for all ODRs (from 13 Hz up to 1.6 kHz).

To enable the low-power and normal mode, the G_HM_MODE bit has to be set to '1'. Low-power mode is available for lower ODR (13, 26, 52 Hz) while normal mode is available for ODRs equal to 104 and 208 Hz.

5.3 Accelerometer power modes

In the LSM6DS3H, the accelerometer can be configured in four different operating modes: power-down, low-power, normal mode and high-performance mode. The operating mode selected depends on the value of the XL_HM_MODE bit in [CTRL6_C \(15h\)](#). If XL_HM_MODE is set to '0', high-performance mode is valid for all ODRs (from 13 Hz up to 6.66 kHz).

To enable the low-power and normal mode, the XL_HM_MODE bit has to be set to '1'. Low-power mode is available for lower ODRs (13, 26, 52 Hz) while normal mode is available for ODRs equal to 104 and 208 Hz.

5.4 Interface flexibility with auxiliary SPI

In Mode3 configuration of the LSM6DS3H, interface flexibility is supported as follows:

- Primary interface: I²C or SPI (3/4-wire)
- Auxiliary interface: SPI (3-wire)

This configuration can support OIS applications, see details in the following figure.

Figure 5. Mode 3 interface configuration (OIS applications)

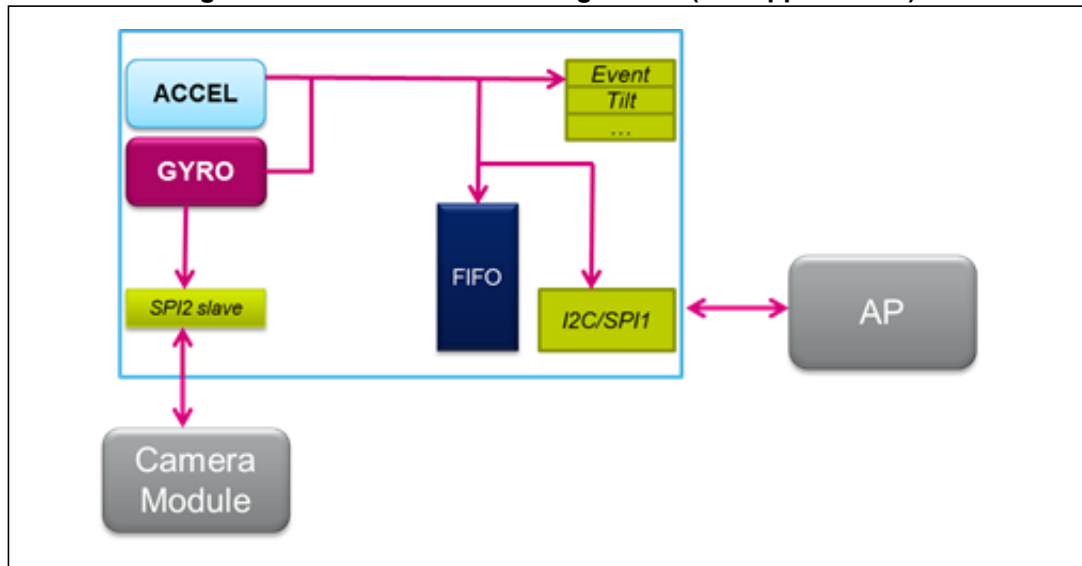

The primary interface is always available and the gyroscope output values are in registers 22h to 27h as per user-selected FS and ODR.

The auxiliary interface needs to be enabled in *CTRL_SPIAux (70h)* register and gyroscope output values are in registers 22h to 27h with FS = 250 dps and ODR = 3.3 kHz. In this interface SPI can write only to the dedicated register (*CTRL_SPIAux (70h)*). When the auxiliary SPI is connected to the camera module, the recommendations are as follows:

- Single axis enable bits in *CTRL9_XL (18h)* and *CTRL10_C (19h)* have to be '1' (default value)
- Sign and orient bits in *ORIENT_CFG_G (0Bh)* have to be set to '0' (default value)
- Sleep bit in *CTRL4_C (13h)* has to be set to '0' (default value)
- Avoid using the self-test if the camera module is reading data

When the camera module is not connected, the device has the same behavior as the LSM6DS3 (all bits supported).

5.5 FIFO

The presence of a FIFO allows consistent power saving for the system since the host processor does not need continuously poll data from the sensor, but it can wake up only when needed and burst the significant data out from the FIFO.

LSM6DS3H embeds 4 kbyte FIFO + flexible 4 kbyte (FIFO or programmable) to store the following data:

- gyroscope
- accelerometer
- external sensors
- step counter and time stamp
- temperature

Writing data in the FIFO can be configured to be triggered by the:

- accelerometer/gyroscope data-ready signal; in which case the ODR must be lower than or equal to both the accelerometer and gyroscope ODRs;
- sensor hub data-ready signal;
- step detection signal.

In addition, each data can be stored at a decimated data rate compared to FIFO ODR and it is configurable by the user, setting the registers *FIFO_CTRL3 (08h)* and *FIFO_CTRL4 (09h)*. The available decimation factors are 2, 3, 4, 8, 16, 32.

Programmable FIFO threshold can be set in *FIFO_CTRL1 (06h)* and *FIFO_CTRL2 (07h)* using the FTH [11:0] bits.

To monitor the FIFO status, dedicated registers (*FIFO_STATUS1 (3Ah)*, *FIFO_STATUS2 (3Bh)*, *FIFO_STATUS3 (3Ch)*, *FIFO_STATUS4 (3Dh)*) can be read to detect FIFO overrun events, FIFO full status, FIFO empty status, FIFO threshold status and the number of unread samples stored in the FIFO. To generate dedicated interrupts on the INT1 and INT2 pads of these status events, the configuration can be set in *INT1_CTRL (0Dh)* and *INT2_CTRL (0Eh)*.

FIFO buffer can be configured according to five different modes:

- Bypass mode
- FIFO mode
- Continuous mode
- Continuous-to-FIFO mode
- Bypass-to-continuous mode

Each mode is selected by the FIFO_MODE_[2:0] in *FIFO_CTRL5 (0Ah)* register. To guarantee the correct acquisition of data during the switching into and out of FIFO mode, the first sample acquired must be discarded.

5.5.1 Bypass mode

In Bypass mode (*FIFO_CTRL5 (0Ah)* (FIFO_MODE_[2:0] = 000), the FIFO is not operational and it remains empty.

Bypass mode is also used to reset the FIFO when in FIFO mode.

5.5.2 FIFO mode

In FIFO mode (*FIFO_CTRL5 (0Ah)* (FIFO_MODE_[2:0] = 001) data from the output channels are stored in the FIFO until it is full.

To reset FIFO content, Bypass mode should be selected by writing *FIFO_CTRL5 (0Ah)* (FIFO_MODE_[2:0]) to '000'. After this reset command, it is possible to restart FIFO mode by writing *FIFO_CTRL5 (0Ah)* (FIFO_MODE_[2:0]) to '001'.

FIFO buffer memorizes up to 4096 samples of 16 bits each but the depth of the FIFO can be resized by setting the FTH [11:0] bits in *FIFO_CTRL1 (06h)* and *FIFO_CTRL2 (07h)*. If the STOP_ON_FTH bit in *CTRL4_C (13h)* is set to '1', FIFO depth is limited up to FTH [11:0] bits in *FIFO_CTRL1 (06h)* and *FIFO_CTRL2 (07h)*.

5.5.3 Continuous mode

Continuous mode (*FIFO_CTRL5 (0Ah)* (FIFO_MODE_[2:0] = 110) provides a continuous FIFO update: as new data arrives, the older data is discarded.

A FIFO threshold flag *FIFO_STATUS2 (3Bh)*(FTH) is asserted when the number of unread samples in FIFO is greater than or equal to *FIFO_CTRL1 (06h)* and *FIFO_CTRL2 (07h)*(FTH [11:0]).

It is possible to route *FIFO_STATUS2 (3Bh)* (FTH) to the INT1 pin by writing in register *INT1_CTRL (0Dh)* (INT1_FTH) = '1' or to the INT2 pin by writing in register *INT2_CTRL (0Eh)* (INT2_FTH) = '1'.

A full-flag interrupt can be enabled, *INT1_CTRL (0Dh)* (INT_FULL_FLAG) = '1', in order to indicate FIFO saturation and eventually read its content all at once.

If an overrun occurs, at least one of the oldest samples in FIFO has been overwritten and the OVER_RUN flag in *FIFO_STATUS2 (3Bh)* is asserted.

In order to empty the FIFO before it is full, it is also possible to pull from FIFO the number of unread samples available in *FIFO_STATUS1 (3Ah)* and *FIFO_STATUS2 (3Bh)* (DIFF_FIFO[11:0]).

5.5.4 Continuous-to-FIFO mode

In Continuous-to-FIFO mode (*FIFO_CTRL5 (0Ah)* (FIFO_MODE_[2:0] = 011), FIFO behavior changes according to the trigger event detected in one of the following interrupt registers *FUNC_SRC (53h)*, *TAP_SRC (1Ch)*, *WAKE_UP_SRC (1Bh)* and *D6D_SRC (1Dh)*.

When the selected trigger bit is equal to '1', FIFO operates in FIFO mode.

When the selected trigger bit is equal to '0', FIFO operates in Continuous mode.

5.5.5 Bypass-to-Continuous mode

In Bypass-to-Continuous mode (*FIFO_CTRL5 (0Ah)* (FIFO_MODE_[2:0] = '100'), data measurement storage inside FIFO operates in Continuous mode when selected triggers in one of the following interrupt registers *FUNC_SRC (53h)*, *TAP_SRC (1Ch)*, *WAKE_UP_SRC (1Bh)* and *D6D_SRC (1Dh)* are equal to '1', otherwise FIFO content is reset (Bypass mode).

5.5.6 FIFO reading procedure

The data stored in FIFO are accessible from dedicated registers (*FIFO_DATA_OUT_L (3Eh)* and *FIFO_DATA_OUT_H (3Fh)*) and each FIFO sample is composed of 16 bits.

All FIFO status registers (*FIFO_STATUS1 (3Ah)*, *FIFO_STATUS2 (3Bh)*, *FIFO_STATUS3 (3Ch)*, *FIFO_STATUS4 (3Dh)*) can be read at the start of a reading operation, minimizing the intervention of the application processor.

Saving data in the FIFO buffer is organized in four FIFO data sets consisting of 6 bytes each:

The 1st FIFO data set is reserved for gyroscope data;

The 2nd FIFO data set is reserved for accelerometer data;

The 3rd FIFO data set is reserved for the external sensor data stored in the registers from *SENSORHUB1_REG (2Eh)* to *SENSORHUB6_REG (33h)*;

The 4th FIFO data set can be alternately associated to the external sensor data stored in the registers from *SENSORHUB7_REG (34h)* to *SENSORHUB12_REG(39h)*, to the step counter and time stamp info, or to the temperature sensor data.

5.5.7 Filter block diagrams

Figure 6. Accelerometer chain

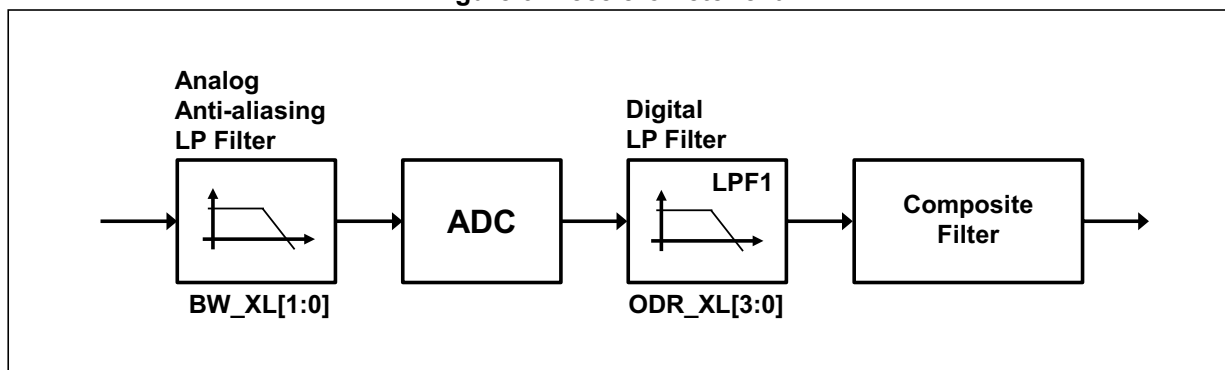

Figure 7. Accelerometer composite filter

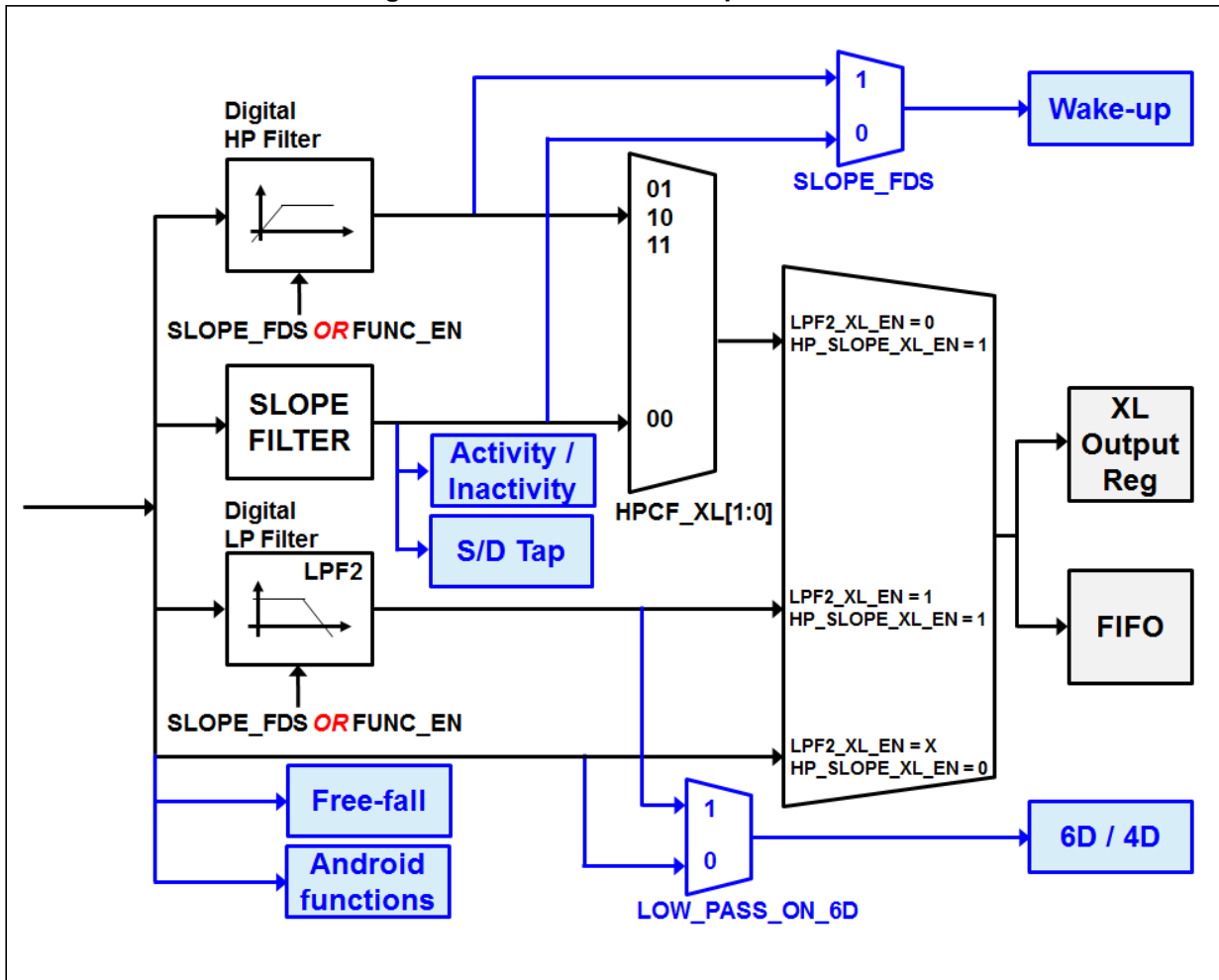
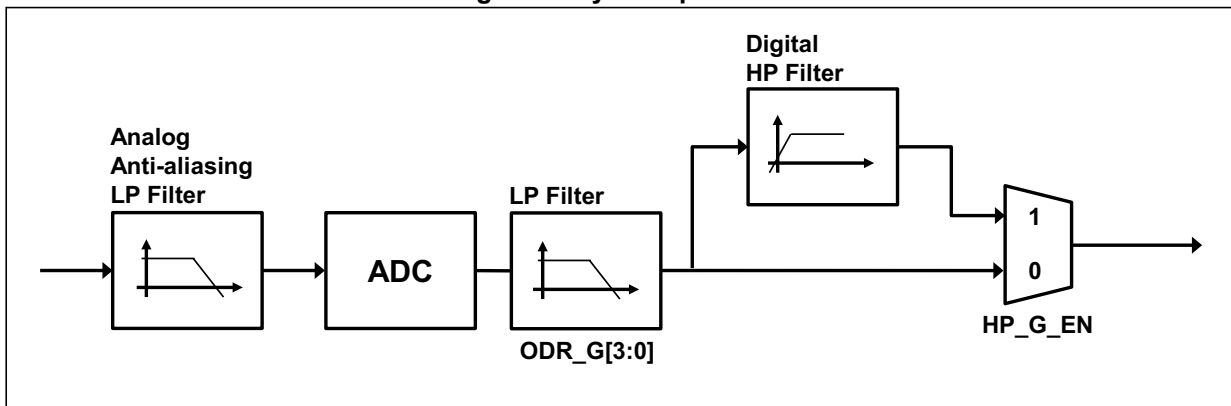

Figure 8. Gyroscope chain



6 Digital interfaces

The registers embedded inside the LSM6DS3H may be accessed through both the I²C and SPI serial interfaces. The latter may be SW configured to operate either in 3-wire or 4-wire interface mode.

The serial interfaces are mapped onto the same pins. To select/exploit the I²C interface, the CS line must be tied high (i.e connected to Vdd_IO).

Table 9. Serial interface pin description

Pin name	Pin description
CS	SPI enable I ² C/SPI mode selection (1: SPI idle mode / I ² C communication enabled; 0: SPI communication mode / I ² C disabled)
SCL/SPC	I ² C Serial Clock (SCL) SPI Serial Port Clock (SPC)
SDA/SDI/SDO	I ² C Serial Data (SDA) SPI Serial Data Input (SDI) 3-wire Interface Serial Data Output (SDO)
SDO/SA0	SPI Serial Data Output (SDO) I ² C less significant bit of the device address

6.1 I²C serial interface

The LSM6DS3H I²C is a bus slave. The I²C is employed to write the data to the registers, whose content can also be read back.

The relevant I²C terminology is provided in the table below.

Table 10. I²C terminology

Term	Description
Transmitter	The device which sends data to the bus
Receiver	The device which receives data from the bus
Master	The device which initiates a transfer, generates clock signals and terminates a transfer
Slave	The device addressed by the master

There are two signals associated with the I²C bus: the serial clock line (SCL) and the Serial DATA line (SDA). The latter is a bidirectional line used for sending and receiving the data to/from the interface. Both the lines must be connected to Vdd_IO through external pull-up resistors. When the bus is free, both the lines are high.

The I²C interface is implemented with fast mode (400 kHz) I²C standards as well as with the standard mode.

In order to disable the I²C block, (I2C_disable) = 1 must be written in [CTRL4_C \(13h\)](#).

6.1.1 I²C operation

The transaction on the bus is started through a START (ST) signal. A START condition is defined as a HIGH to LOW transition on the data line while the SCL line is held HIGH. After this has been transmitted by the master, the bus is considered busy. The next byte of data transmitted after the start condition contains the address of the slave in the first 7 bits and the eighth bit tells whether the master is receiving data from the slave or transmitting data to the slave. When an address is sent, each device in the system compares the first seven bits after a start condition with its address. If they match, the device considers itself addressed by the master.

The Slave Address (SAD) associated to the LSM6DS3H is 110101xb. The SDO/SA0 pin can be used to modify the less significant bit of the device address. If the SDO/SA0 pin is connected to the supply voltage, LSb is '1' (address 1101011b); else if the SDO/SA0 pin is connected to ground, the LSb value is '0' (address 1101010b). This solution permits to connect and address two different inertial modules to the same I²C bus.

Data transfer with acknowledge is mandatory. The transmitter must release the SDA line during the acknowledge pulse. The receiver must then pull the data line LOW so that it remains stable low during the HIGH period of the acknowledge clock pulse. A receiver which has been addressed is obliged to generate an acknowledge after each byte of data received.

The I²C embedded inside the LSM6DS3H behaves like a slave device and the following protocol must be adhered to. After the start condition (ST) a slave address is sent, once a slave acknowledge (SAK) has been returned, an 8-bit sub-address (SUB) is transmitted. The increment of the address is configured by the *CTRL3_C (12h)* (IF_INC).

The slave address is completed with a Read/Write bit. If the bit is '1' (Read), a repeated START (SR) condition must be issued after the two sub-address bytes; if the bit is '0' (Write) the master will transmit to the slave with direction unchanged. *Table 11* explains how the SAD+Read/Write bit pattern is composed, listing all the possible configurations.

Table 11. SAD+Read/Write patterns

Command	SAD[6:1]	SAD[0] = SA0	R/W	SAD+R/W
Read	110101	0	1	11010101 (D5h)
Write	110101	0	0	11010100 (D4h)
Read	110101	1	1	11010111 (D7h)
Write	110101	1	0	11010110 (D6h)

Table 12. Transfer when master is writing one byte to slave

Master	ST	SAD + W		SUB		DATA		SP
Slave			SAK		SAK		SAK	

Table 13. Transfer when master is writing multiple bytes to slave

Master	ST	SAD + W		SUB		DATA		DATA		SP
Slave			SAK		SAK		SAK		SAK	

Table 14. Transfer when master is receiving (reading) one byte of data from slave

Master	ST	SAD + W		SUB		SR	SAD + R			NMAK	SP
Slave			SAK		SAK			SAK	DATA		

Table 15. Transfer when master is receiving (reading) multiple bytes of data from slave

Master	ST	SAD+W		SUB		SR	SAD+R			MAK		MAK		NMAK	SP
Slave			SAK		SAK			SAK	DATA		DATA		DATA		

Data are transmitted in byte format (DATA). Each data transfer contains 8 bits. The number of bytes transferred per transfer is unlimited. Data is transferred with the Most Significant bit (MSb) first. If a receiver can't receive another complete byte of data until it has performed some other function, it can hold the clock line, SCL LOW to force the transmitter into a wait state. Data transfer only continues when the receiver is ready for another byte and releases the data line. If a slave receiver doesn't acknowledge the slave address (i.e. it is not able to receive because it is performing some real-time function) the data line must be left HIGH by the slave. The master can then abort the transfer. A LOW to HIGH transition on the SDA line while the SCL line is HIGH is defined as a STOP condition. Each data transfer must be terminated by the generation of a STOP (SP) condition.

In the presented communication format MAK is Master acknowledge and NMAK is No Master Acknowledge.

6.2 SPI bus interface

The LSM6DS3H SPI is a bus slave. The SPI allows writing and reading the registers of the device.

The serial interface communicates to the application using 4 wires: **CS**, **SPC**, **SDI** and **SDO**.

Figure 9. Read and write protocol

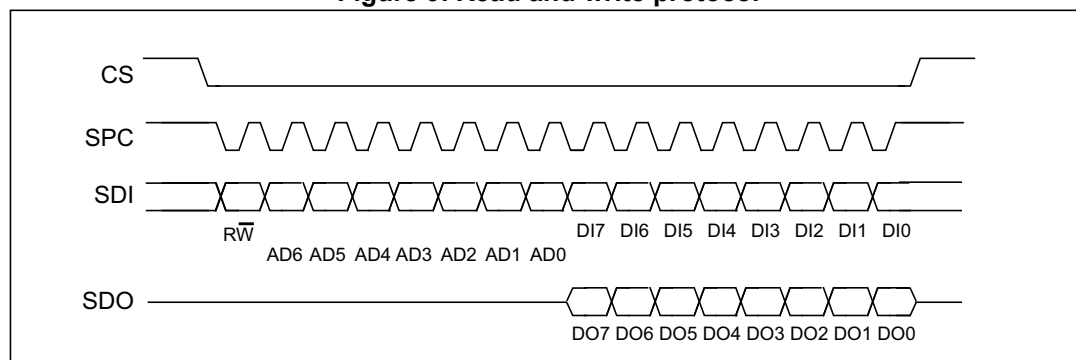

CS is the serial port enable and it is controlled by the SPI master. It goes low at the start of the transmission and goes back high at the end. **SPC** is the serial port clock and it is controlled by the SPI master. It is stopped high when **CS** is high (no transmission). **SDI** and **SDO** are, respectively, the serial port data input and output. Those lines are driven at the falling edge of **SPC** and should be captured at the rising edge of **SPC**.

Both the read register and write register commands are completed in 16 clock pulses or in multiples of 8 in case of multiple read/write bytes. Bit duration is the time between two falling edges of **SPC**. The first bit (bit 0) starts at the first falling edge of **SPC** after the falling edge of **CS** while the last bit (bit 15, bit 23, ...) starts at the last falling edge of **SPC** just before the rising edge of **CS**.

bit 0: \overline{RW} bit. When 0, the data $DI(7:0)$ is written into the device. When 1, the data $DO(7:0)$ from the device is read. In latter case, the chip will drive **SDO** at the start of bit 8.

bit 1-7: address $AD(6:0)$. This is the address field of the indexed register.

bit 8-15: data $DI(7:0)$ (write mode). This is the data that is written into the device (MSb first).

bit 8-15: data $DO(7:0)$ (read mode). This is the data that is read from the device (MSb first).

In multiple read/write commands further blocks of 8 clock periods will be added. When the **CTRL3_C (12h)** (**IF_INC**) bit is '0', the address used to read/write data remains the same for every block. When the **CTRL3_C (12h)** (**IF_INC**) bit is '1', the address used to read/write data is increased at every block.

The function and the behavior of **SDI** and **SDO** remain unchanged.

6.2.1 SPI read

Figure 10. SPI read protocol

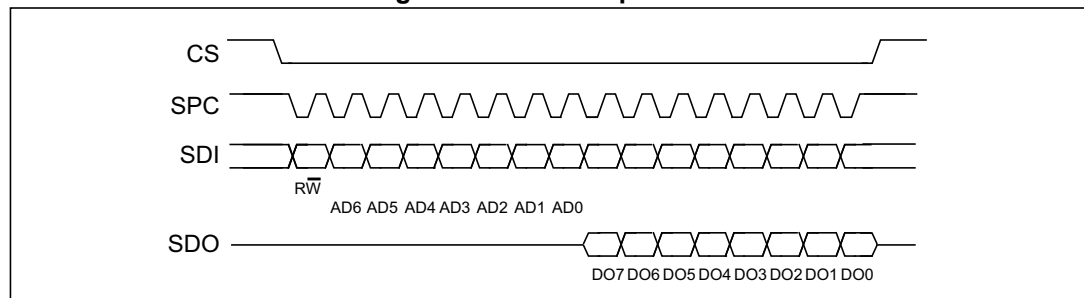

The SPI Read command is performed with 16 clock pulses. A multiple byte read command is performed by adding blocks of 8 clock pulses to the previous one.

bit 0: READ bit. The value is 1.

bit 1-7: address $AD(6:0)$. This is the address field of the indexed register.

bit 8-15: data $DO(7:0)$ (read mode). This is the data that will be read from the device (MSb first).

bit 16-...: data $DO(...-8)$. Further data in multiple byte reads.

Figure 11. Multiple byte SPI read protocol (2-byte example)

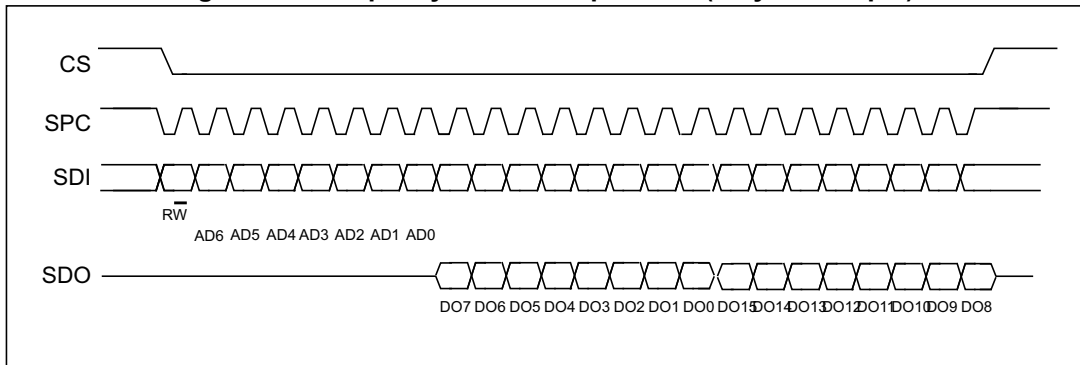

6.2.2 SPI write

Figure 12. SPI write protocol

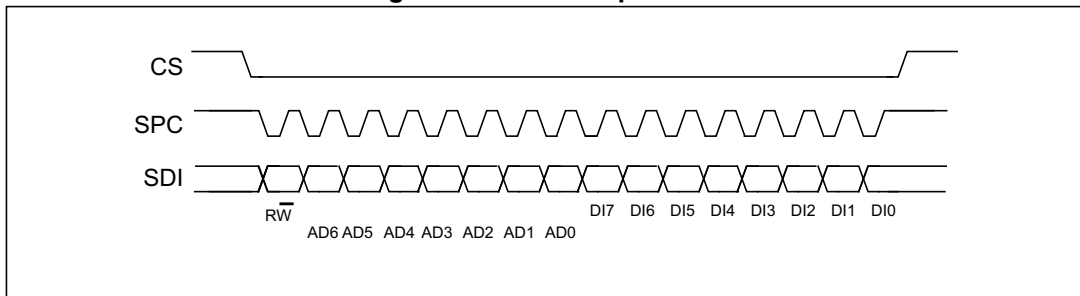

The SPI Write command is performed with 16 clock pulses. A multiple byte write command is performed by adding blocks of 8 clock pulses to the previous one.

bit 0: WRITE bit. The value is 0.

bit 1 -7: address AD(6:0). This is the address field of the indexed register.

bit 8-15: data DI(7:0) (write mode). This is the data that is written inside the device (MSb first).

bit 16-... : data DI(...-8). Further data in multiple byte writes.

Figure 13. Multiple byte SPI write protocol (2-byte example)

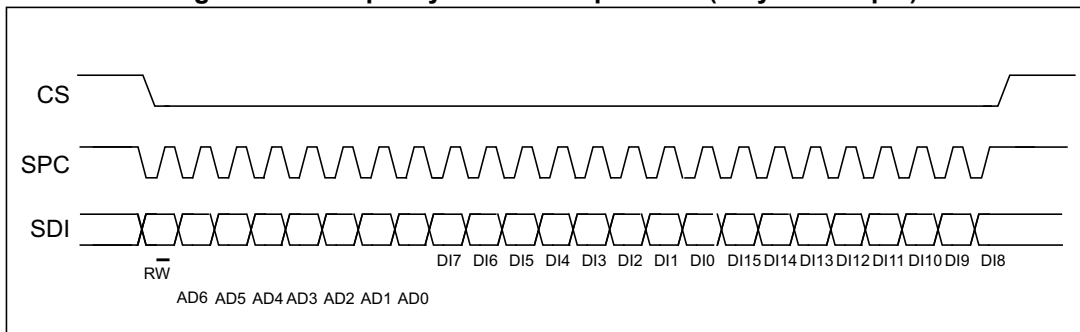

6.2.3 SPI read in 3-wire mode

A 3-wire mode is entered by setting the *CTRL3_C (12h)* (SIM) bit equal to '1' (SPI serial interface mode selection).

Figure 14. SPI read protocol in 3-wire mode

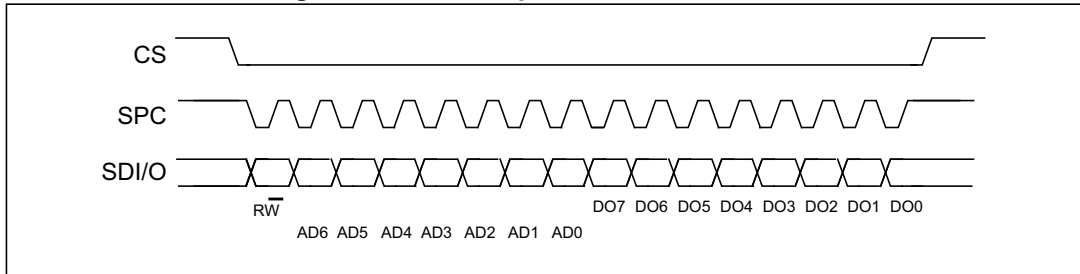

The SPI read command is performed with 16 clock pulses:

bit 0: READ bit. The value is 1.

bit 1-7: address AD(6:0). This is the address field of the indexed register.

bit 8-15: data DO(7:0) (read mode). This is the data that is read from the device (MSb first).

A multiple read command is also available in 3-wire mode.

7 Application hints

7.1 LSM6DS3H electrical connections in Mode 1

Figure 15. LSM6DS3H electrical connections in Mode 1

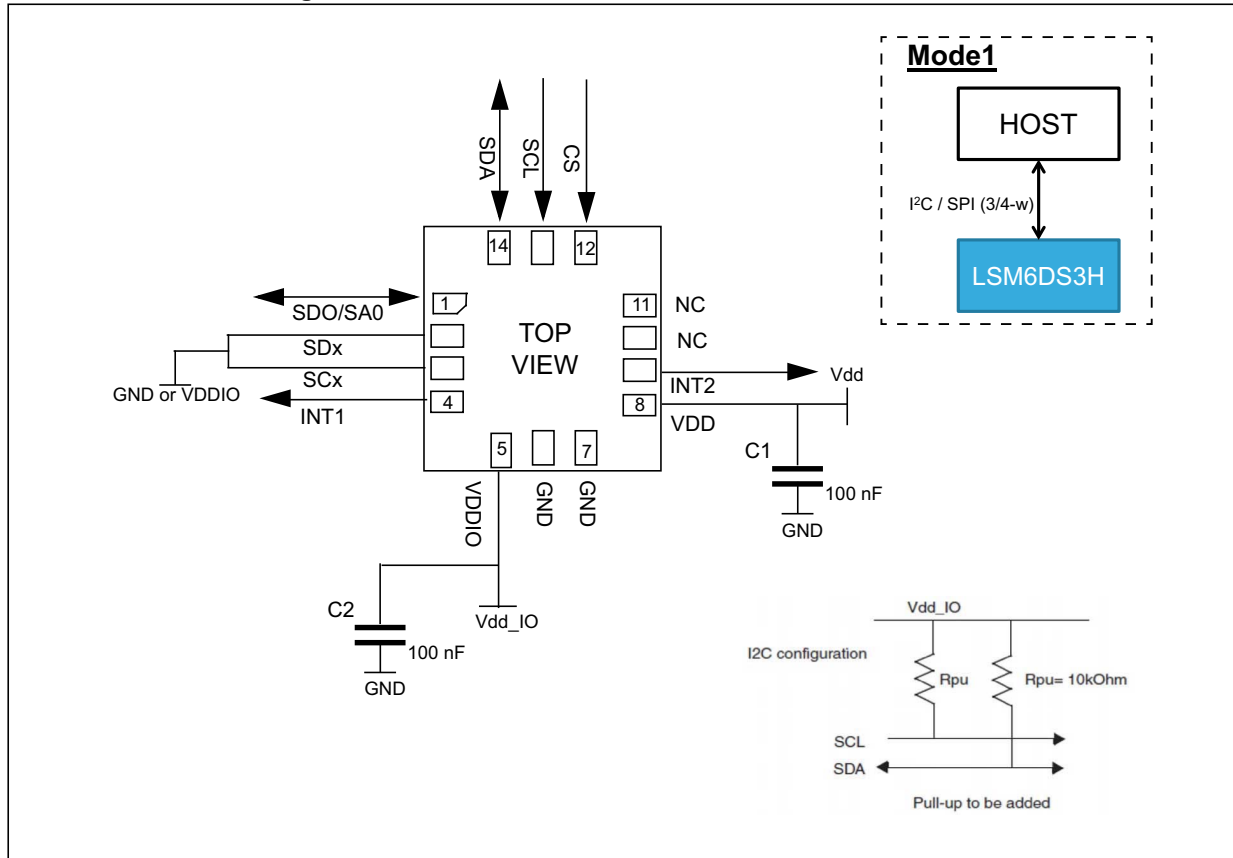

The device core is supplied through the Vdd line. Power supply decoupling capacitors (C1, C2 = 100 nF ceramic) should be placed as near as possible to the supply pin of the device (common design practice).

The functionality of the device and the measured acceleration/angular rate data is selectable and accessible through the SPI/I²C interface.

The functions, the threshold and the timing of the two interrupt pins for each sensor can be completely programmed by the user through the SPI/I²C interface.

7.2 LSM6DS3H electrical connections in Mode 2

Figure 16. LSM6DS3H electrical connections in Mode 2

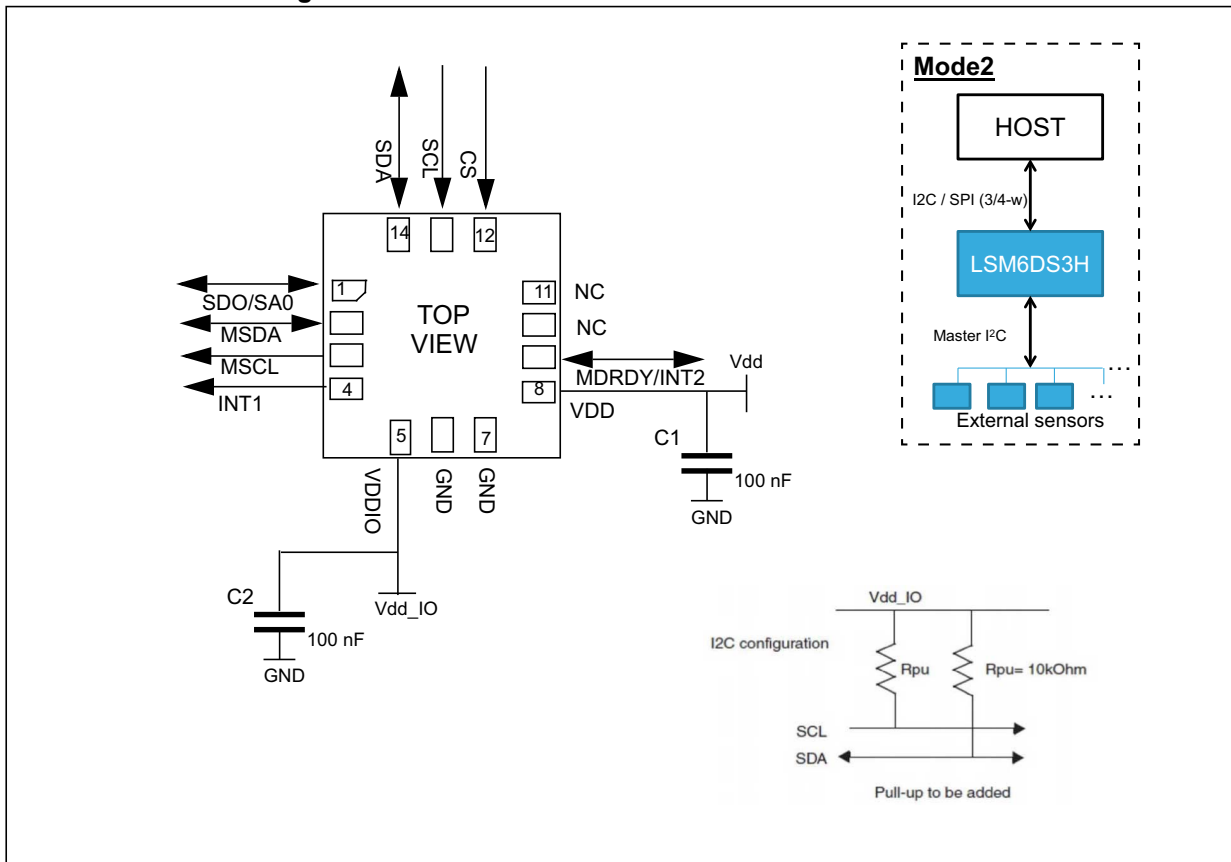

The device core is supplied through the Vdd line. Power supply decoupling capacitors (C1, C2 = 100 nF ceramic) should be placed as near as possible to the supply pin of the device (common design practice).

The functionality of the device and the measured acceleration/angular rate data is selectable and accessible through the SPI/I²C interface.

The functions, the threshold and the timing of the two interrupt pins for each sensor can be completely programmed by the user through the SPI/I²C interface.

7.3 LSM6DS3H electrical connections in Mode 3

SPI 4-wire for primary interface and SPI 3-wire for auxiliary interface.

Figure 17. LSM6DS3H electrical connections in Mode 3

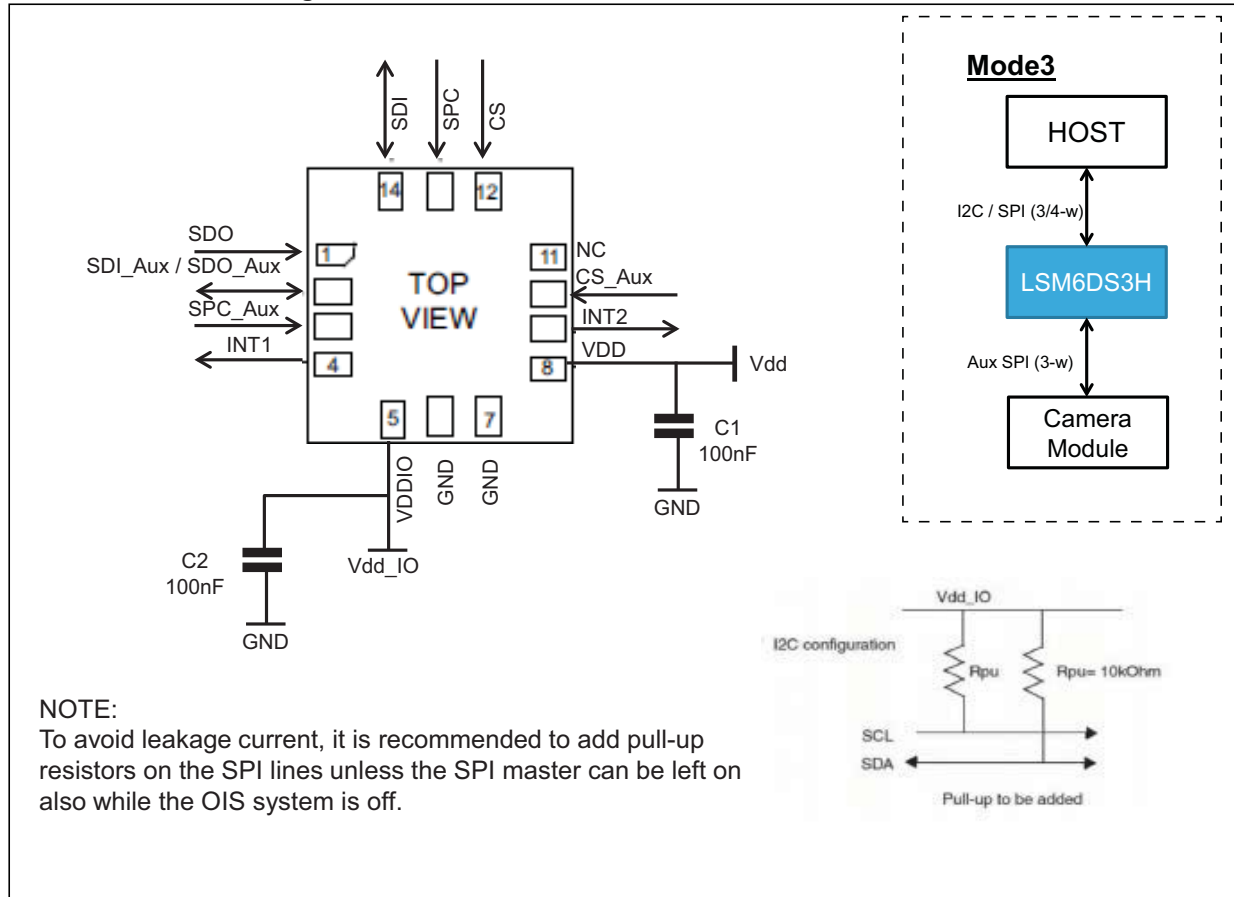

The device core is supplied through the Vdd line. Power supply decoupling capacitors (C1, C2 = 100 nF ceramic) should be placed as near as possible to the supply pin of the device (common design practice).

The functionality of the device and the measured acceleration/angular rate data is selectable and accessible through the SPI/I²C interface.

The functions, the threshold and the timing of the two interrupt pins for each sensor can be completely programmed by the user through the SPI/I²C interface.

In the primary SPI connection, the gyroscope output data is available in registers 22h to 27h with user-selected FS and ODR. In the auxiliary SPI, the gyroscope output is available in registers 22h to 27h @ 3.3 kHz and FS = 250 dps.

8 Register mapping

The table given below provides a list of the 8/16 bit registers embedded in the device and the corresponding addresses.

Table 16. Registers address map

Name	Type	Register address		Default	Comment
		Hex	Binary		
RESERVED	r/w	00	00000000	00000000	Reserved
FUNC_CFG_ACCESS	r/w	01	00000001	00000000	Embedded functions configuration register
RESERVED	r/w	02	00000010	-	Reserved
RESERVED	r/w	03	00000011	-	Reserved
SENSOR_SYNC_TIME_FRAME	r/w	04	00000100	00000000	Sensor sync configuration register
RESERVED	r/w	05	00000101	-	Reserved
FIFO_CTRL1	r/w	06	00000110	00000000	FIFO configuration registers
FIFO_CTRL2	r/w	07	00000111	00000000	
FIFO_CTRL3	r/w	08	00001000	00000000	
FIFO_CTRL4	r/w	09	00001001	00000000	
FIFO_CTRL5	r/w	0A	00001010	00000000	
ORIENT_CFG_G	r/w	0B	00001011	00000000	
RESERVED	r/w	0C	00001100	-	Reserved
INT1_CTRL	r/w	0D	00001101	00000000	INT1 pin control
INT2_CTRL	r/w	0E	00001110	00000000	INT2 pin control
WHO_AM_I	r	0F	00001111	01101001	Who I am ID
CTRL1_XL	r/w	10	00010000	00000000	Accelerometer and gyroscope control registers
CTRL2_G	r/w	11	00010001	00000000	
CTRL3_C	r/w	12	00010010	00000100	
CTRL4_C	r/w	13	00010011	00000000	
CTRL5_C	r/w	14	00010100	00000000	
CTRL6_C	r/w	15	00010101	00000000	
CTRL7_G	r/w	16	00010110	00000000	
CTRL8_XL	r/w	17	0001 0111	00000000	
CTRL9_XL	r/w	18	00011000	00111000	
CTRL10_C	r/w	19	00011001	00111000	

Table 16. Registers address map (continued)

Name	Type	Register address		Default	Comment
		Hex	Binary		
MASTER_CONFIG	r/w	1A	00011010	00000000	I ² C master configuration register
WAKE_UP_SRC	r	1B	00011011	output	Interrupt registers
TAP_SRC	r	1C	00011100	output	
D6D_SRC	r	1D	00011101	output	
STATUS_REG ⁽¹⁾ / STATUS_SPIAux ⁽²⁾	r	1E	00011110	output	Status data register for user interface and OIS data
RESERVED	r	1F	00011111	-	Reserved
OUT_TEMP_L	r	20	00100000	output	Temperature output data registers
OUT_TEMP_H	r	21	00100001	output	
OUTX_L_G	r	22	00100010	output	Gyroscope output registers for user interface and OIS data
OUTX_H_G	r	23	00100011	output	
OUTY_L_G	r	24	00100100	output	
OUTY_H_G	r	25	00100101	output	
OUTZ_L_G	r	26	00100110	output	
OUTZ_H_G	r	27	00100111	output	
OUTX_L_XL	r	28	00101000	output	Accelerometer output registers
OUTX_H_XL	r	29	00101001	output	
OUTY_L_XL	r	2A	00101010	output	
OUTY_H_XL	r	2B	00101011	output	
OUTZ_L_XL	r	2C	00101100	output	
OUTZ_H_XL	r	2D	00101101	output	

Table 16. Registers address map (continued)

Name	Type	Register address		Default	Comment
		Hex	Binary		
SENSORHUB1_REG	r	2E	00101110	output	Sensor hub output registers
SENSORHUB2_REG	r	2F	00101111	output	
SENSORHUB3_REG	r	30	00110000	output	
SENSORHUB4_REG	r	31	00110001	output	
SENSORHUB5_REG	r	32	00110010	output	
SENSORHUB6_REG	r	33	00110011	output	
SENSORHUB7_REG	r	34	00110100	output	
SENSORHUB8_REG	r	35	00110101	output	
SENSORHUB9_REG	r	36	00110110	output	
SENSORHUB10_REG	r	37	00110111	output	
SENSORHUB11_REG	r	38	00111000	output	
SENSORHUB12_REG	r	39	00111001	output	
FIFO_STATUS1	r	3A	00111010	output	FIFO status registers
FIFO_STATUS2	r	3B	00111011	output	
FIFO_STATUS3	r	3C	00111100	output	
FIFO_STATUS4	r	3D	00111101	output	
FIFO_DATA_OUT_L	r	3E	00111110	output	FIFO data output registers
FIFO_DATA_OUT_H	r	3F	00111111	output	
TIMESTAMP0_REG	r	40	01000000	output	Timestamp output registers
TIMESTAMP1_REG	r	41	01000001	output	
TIMESTAMP2_REG	r/w	42	01000010	output	
RESERVED		43-48		--	Reserved
STEP_TIMESTAMP_L	r	49	0100 1001	output	Step counter timestamp registers
STEP_TIMESTAMP_H	r	4A	0100 1010	output	
STEP_COUNTER_L	r	4B	01001011	output	Step counter output registers
STEP_COUNTER_H	r	4C	01001100	output	
SENSORHUB13_REG	r	4D	01001101	output	Sensor hub output registers
SENSORHUB14_REG	r	4E	01001110	output	
SENSORHUB15_REG	r	4F	01001111	output	
SENSORHUB16_REG	r	50	01010000	output	
SENSORHUB17_REG	r	51	01010001	output	
SENSORHUB18_REG	r	52	01010010	output	
FUNC_SRC	r	53	01010011	output	Interrupt register

Table 16. Registers address map (continued)

Name	Type	Register address		Default	Comment
		Hex	Binary		
RESERVED		54-57		--	Reserved
TAP_CFG	r/w	58	01011000	00000000	Interrupt registers
TAP_THS_6D	r/w	59	01011001	00000000	
INT_DUR2	r/w	5A	01011010	00000000	
WAKE_UP_THS	r/w	5B	01011011	00000000	
WAKE_UP_DUR	r/w	5C	01011100	00000000	
FREE_FALL	r/w	5D	01011101	00000000	
MD1_CFG	r/w	5E	01011110	00000000	
MD2_CFG	r/w	5F	01011111	00000000	
RESERVED		60-65		-	Reserved
OUT_MAG_RAW_X_L	r	66	0110 0110	output	External magnetometer raw data output registers
OUT_MAG_RAW_X_H	r	67	0110 0111	output	
OUT_MAG_RAW_Y_L	r	68	0110 1000	output	
OUT_MAG_RAW_Y_H	r	69	0110 1001	output	
OUT_MAG_RAW_Z_L	r	6A	0110 1010	output	
OUT_MAG_RAW_Z_H	r	6B	0110 1011	output	
CTRL_SPIAux		70	0111 0000		

1. This register status is read using the primary interface for user interface gyroscope data.
2. This register status is read using the auxiliary SPI for OIS gyroscope data.

Registers marked as *Reserved* must not be changed. Writing to those registers may cause permanent damage to the device.

The content of the registers that are loaded at boot should not be changed. They contain the factory calibration values. Their content is automatically restored when the device is powered up.

9 Register description

The device contains a set of registers which are used to control its behavior and to retrieve linear acceleration, angular rate and temperature data. The register addresses, made up of 7 bits, are used to identify them and to write the data through the serial interface.

9.1 FUNC_CFG_ACCESS (01h)

Enable embedded functions register (r/w).

Table 17. FUNC_CFG_ACCESS register

FUNC_CFG_EN	0 ⁽¹⁾	0 ⁽¹⁾	0 ⁽¹⁾	0 ⁽¹⁾	0 ⁽¹⁾	0 ⁽¹⁾	0 ⁽¹⁾
-------------	------------------	------------------	------------------	------------------	------------------	------------------	------------------

1. This bit must be set to '0' for the correct operation of the device.

Table 18. FUNC_CFG_ACCESS register description

FUNC_CFG_EN	Enable access to the embedded functions configuration registers ⁽¹⁾ from address 02h to 32h. Default value: 0. (0: disable access to embedded functions configuration registers; 1: enable access to embedded functions configuration registers)
-------------	---

1. The embedded functions configuration registers details are available in [10: Embedded functions register mapping](#) and [11: Embedded functions registers description](#).

9.2 SENSOR_SYNC_TIME_FRAME (04h)

Sensor synchronization time frame register (r/w).

Table 19. SENSOR_SYNC_TIME_FRAME register

TPH_7	TPH_6	TPH_5	TPH_4	TPH_3	TPH_2	TPH_1	TPH_0
-------	-------	-------	-------	-------	-------	-------	-------

Table 20. ISENSOR_SYNC_TIME_FRAME register description

TPH_ [7:0]	Sensor synchronization time frame with the step of 500 ms and full range of 5 s. Unsigned 8-bit. Default value: 0000 0000
------------	---

9.3 FIFO_CTRL1 (06h)

FIFO control register (r/w).

Table 21. FIFO_CTRL1 register

FTH_7	FTH_6	FTH_5	FTH_4	FTH_3	FTH_2	FTH_1	FTH_0
-------	-------	-------	-------	-------	-------	-------	-------

Table 22. FIFO_CTRL1 register description

FTH_ [7:0]	FIFO threshold level setting ⁽¹⁾ . Default value: 0000 0000. Watermark flag rises when the number of bytes written to FIFO after the next write is greater than or equal to the threshold level. Minimum resolution for the FIFO is 1 LSB = 2 bytes (1 word) in FIFO
------------	---

1. For a complete watermark threshold configuration, consider FTH_ [11:8] in [FIFO_CTRL2 \(07h\)](#).

9.4 FIFO_CTRL2 (07h)

FIFO control register (r/w).

Table 23. FIFO_CTRL2 register

TIMER_PEDO_FIF0_EN	TIMER_PEDO_FIF0_DRDY	0 ⁽¹⁾	0 ⁽¹⁾	FTH_11	FTH10	FTH_9	FTH_8
--------------------	----------------------	------------------	------------------	--------	-------	-------	-------

1. This bit must be set to '0' for the correct operation of the device.

Table 24. FIFO_CTRL2 register description

TIMER_PEDO_FIF0_EN	Enable pedometer step counter and time stamp as 4 th FIFO data set. Default: 0 (0: disable step counter and time stamp data as 4 th FIFO data set; 1: enable step counter and time stamp data as 4 th FIFO data set)
TIMER_PEDO_FIF0_DRDY	FIFO write mode ⁽¹⁾ . Default: 0 (0: enable write in FIFO based on XL/Gyro data-ready; 1: enable write in FIFO at every step detected by step counter.)
FTH_[11:8]	FIFO threshold level setting ⁽²⁾ . Default value: 0000 Watermark flag rises when the number of bytes written to FIFO after the next write is greater than or equal to the threshold level. Minimum resolution for the FIFO is 1LSB = 2 bytes (1 word) in FIFO

1. This bit is effective if the DATA_VALID_SEL_FIF0 bit of the MASTER_CONFIG (1Ah) register is set to 0.
2. For a complete watermark threshold configuration, consider FTH_[11:8] in [FIFO_CTRL1 \(06h\)](#)

9.5 FIFO_CTRL3 (08h)

FIFO control register (r/w).

Table 25. FIFO_CTRL3 register

0 ⁽¹⁾	0 ⁽¹⁾	DEC_FIF0_GYRO2	DEC_FIF0_GYRO1	DEC_FIF0_GYRO0	DEC_FIF0_XL2	DEC_FIF0_XL1	DEC_FIF0_XL0
------------------	------------------	----------------	----------------	----------------	--------------	--------------	--------------

1. This bit must be set to '0' for the correct operation of the device.

Table 26. FIFO_CTRL3 register description

DEC_FIF0_GYRO [2:0]	Gyro FIFO (first data set) decimation setting. Default: 000 For the configuration setting, refer to Table 27 .
DEC_FIF0_XL [2:0]	Accelerometer FIFO (second data set) decimation setting. Default: 000 For the configuration setting, refer to Table 28 .

Table 27. Gyro FIFO decimation setting

DEC_FIFO_GYRO [2:0]	Configuration
000	Gyro sensor not in FIFO
001	No decimation
010	Decimation with factor 2
011	Decimation with factor 3
100	Decimation with factor 4
101	Decimation with factor 8
110	Decimation with factor 16
111	Decimation with factor 32

Table 28. Accelerometer FIFO decimation setting

DEC_FIFO_XL [2:0]	Configuration
000	Accelerometer sensor not in FIFO
001	No decimation
010	Decimation with factor 2
011	Decimation with factor 3
100	Decimation with factor 4
101	Decimation with factor 8
110	Decimation with factor 16
111	Decimation with factor 32

9.6 FIFO_CTRL4 (09h)

FIFO control register (r/w).

Table 29. FIFO_CTRL4 register

0 ⁽¹⁾	ONLY_HIGH_DATA	DEC_DS4_FIFO2	DEC_DS4_FIFO1	DEC_DS4_FIFO0	DEC_DS3_FIFO2	DEC_DS3_FIFO1	DEC_DS3_FIFO0
------------------	----------------	---------------	---------------	---------------	---------------	---------------	---------------

1. This bit must be set to '0' for the correct operation of the device.

Table 30. FIFO_CTRL4 register description

ONLY_HIGH_DATA	8-bit data storage in FIFO. Default: 0 (0: disable MSByte only memorization in FIFO for XL and Gyro; 1: enable MSByte only memorization in FIFO for XL and Gyro in FIFO)
DEC_DS4_FIFO[2:0]	Fourth FIFO data set decimation setting. Default: 000 For the configuration setting, refer to Table 31 .
DEC_DS3_FIFO[2:0]	Third FIFO data set decimation setting. Default: 000 For the configuration setting, refer to Table 32 .

Table 31. Fourth FIFO data set decimation setting

DEC_DS4_FIFO[2:0]	Configuration
000	Fourth FIFO data set not in FIFO
001	No decimation
010	Decimation with factor 2
011	Decimation with factor 3
100	Decimation with factor 4
101	Decimation with factor 8
110	Decimation with factor 16
111	Decimation with factor 32

Table 32. Third FIFO data set decimation setting

DEC_DS3_FIFO[2:0]	Configuration
000	Third FIFO data set not in FIFO
001	No decimation
010	Decimation with factor 2
011	Decimation with factor 3
100	Decimation with factor 4
101	Decimation with factor 8
110	Decimation with factor 16
111	Decimation with factor 32

9.7 FIFO_CTRL5 (0Ah)

FIFO control register (r/w).

Table 33. FIFO_CTRL5 register

0 ⁽¹⁾	ODR_FIF0_3	ODR_FIF0_2	ODR_FIF0_1	ODR_FIF0_0	FIFO_MODE_2	FIFO_MODE_1	FIFO_MODE_0
------------------	------------	------------	------------	------------	-------------	-------------	-------------

1. This bit must be set to '0' for the correct operation of the device.

Table 34. FIFO_CTRL5 register description

ODR_FIF0_[3:0]	FIFO ODR selection, setting FIFO_MODE also. Default: 0000 For the configuration setting, refer to Table 35
FIFO_MODE_[2:0]	FIFO mode selection bits, setting ODR_FIF0 also. Default value: 000 For the configuration setting refer to Table 36

Table 35. FIFO ODR selection

ODR_FIFO_[3:0]	Configuration ⁽¹⁾
0000	FIFO disabled
0001	FIFO ODR is set to 13 Hz
0010	FIFO ODR is set to 26 Hz
0011	FIFO ODR is set to 52 Hz
0100	FIFO ODR is set to 104 Hz
0101	FIFO ODR is set to 208 Hz
0110	FIFO ODR is set to 416 Hz
0111	FIFO ODR is set to 833 Hz
1000	FIFO ODR is set to 1.66 kHz
1001	FIFO ODR is set to 3.33 kHz
1010	FIFO ODR is set to 6.66 kHz

1. If the device is working at an ODR slower than the one selected, FIFO ODR is limited to that ODR value. Moreover, these bits are effective if both the DATA_VALID_SEL FIFO bit of MASTER_CONFIG (1Ah) and the TIMER_PEDO_FIFO_DRDY bit of FIFO_CTRL2 (07h) are set to 0.

Table 36. FIFO mode selection

FIFO_MODE_[2:0]	Configuration mode
000	Bypass mode. FIFO disabled.
001	FIFO mode. Stops collecting data when FIFO is full.
010	Reserved
011	Continuous mode until trigger is deasserted, then FIFO mode.
100	Bypass mode until trigger is deasserted, then Continuous mode.
101	Reserved
110	Continuous mode. If the FIFO is full, the new sample overwrites the older one.
111	Reserved

9.8 ORIENT_CFG_G (0Bh)

Angular rate sensor sign and orientation register (r/w).

Table 37. ORIENT_CFG_G register

0 ⁽¹⁾	0 ⁽¹⁾	SignX_G	SignY_G	SignZ_G	Orient_2	Orient_1	Orient_0
------------------	------------------	---------	---------	---------	----------	----------	----------

1. This bit must be set to '0' for the correct operation of the device.

Table 38. ORIENT_CFG_G register description

SignX_G	Pitch axis (X) angular rate sign. Default value: 0 (0: positive sign; 1: negative sign)
SignY_G	Roll axis (Y) angular rate sign. Default value: 0 (0: positive sign; 1: negative sign)
SignZ_G	Yaw axis (Z) angular rate sign. Default value: 0 (0: positive sign; 1: negative sign)
Orient [2:0]	Directional user-orientation selection. Default value: 000 For the configuration setting, refer to Table 39 .

Table 39. Settings for orientation of axes

Orient [2:0]	000	001	010	011	100	101
Pitch	X	X	Y	Y	Z	Z
Roll	Y	Z	X	Z	X	Y
Yaw	Z	Y	Z	X	Y	X

9.9 INT1_CTRL (0Dh)

INT1 pad control register (r/w).

Each bit in this register enables a signal to be carried through INT1. The pad's output will supply the OR combination of the selected signals.

Table 40. INT1_CTRL register

INT1_STEP_DETECTOR	INT1_SIGN_MOT	INT1_FULL_FLAG	INT1_FIFO_OVR	INT1_FTH	INT1_BOOT	INT1_DRDY_G	INT1_DRDY_XL
--------------------	---------------	----------------	---------------	----------	-----------	-------------	--------------

Table 41. INT1_CTRL register description

INT1_STEP_DETECTOR	Pedometer step recognition interrupt enable on INT1 pad. Default value: 0 (0: disabled; 1: enabled)
INT1_SIGN_MOT	Significant motion interrupt enable on INT1 pad. Default value: 0 (0: disabled; 1: enabled)
INT1_FULL_FLAG	FIFO full flag interrupt enable on INT1 pad. Default value: 0 (0: disabled; 1: enabled)
INT1_FIFO_OVR	FIFO overrun interrupt on INT1 pad. Default value: 0 (0: disabled; 1: enabled)
INT1_FTH	FIFO threshold interrupt on INT1 pad. Default value: 0 (0: disabled; 1: enabled)
INT1_BOOT	Boot status available on INT1 pad. Default value: 0 (0: disabled; 1: enabled)
INT1_DRDY_G	Gyroscope Data Ready on INT1 pad. Default value: 0 (0: disabled; 1: enabled)
INT1_DRDY_XL	Accelerometer Data Ready on INT1 pad. Default value: 0 (0: disabled; 1: enabled)

9.10 INT2_CTRL (0Eh)

INT2 pad control register (r/w).

Each bit in this register enables a signal to be carried through INT2. The pad's output will supply the OR combination of the selected signals.

Table 42. INT2_CTRL register

INT2_STEP_DELTA	INT2_STEP_COUNT_OV	INT2_FULL_FLAG	INT2_FIFO_OVR	INT2_FTH	INT2_DRDY_TEMP	INT2_DRDY_G	INT2_DRDY_XL
-----------------	--------------------	----------------	---------------	----------	----------------	-------------	--------------

Table 43. INT2_CTRL register description

INT2_STEP_DELTA	Pedometer step recognition interrupt on delta time ⁽¹⁾ enable on INT2 pad. Default value: 0 (0: disabled; 1: enabled)
INT2_STEP_COUNT_OV	Step counter overflow interrupt enable on INT2 pad. Default value: 0 (0: disabled; 1: enabled)
INT2_FULL_FLAG	FIFO full flag interrupt enable on INT2 pad. Default value: 0 (0: disabled; 1: enabled)
INT2_FIFO_OVR	FIFO overrun interrupt on INT2 pad. Default value: 0 (0: disabled; 1: enabled)
INT2_FTH	FIFO threshold interrupt on INT2 pad. Default value: 0 (0: disabled; 1: enabled)
INT2_DRDY_TEMP	Temperature Data Ready in INT2 pad. Default value: 0 (0: disabled; 1: enabled)
INT2_DRDY_G	Gyroscope Data Ready on INT2 pad. Default value: 0 (0: disabled; 1: enabled)
INT2_DRDY_XL	Accelerometer Data Ready on INT2 pad. Default value: 0 (0: disabled; 1: enabled)

1. Delta time value is defined in register STEP_COUNT_DELTA (15h).

9.11 WHO_AM_I (0Fh)

Who_AM_I register (r). This register is a read-only register. Its value is fixed at 69h.

Table 44. WHO_AM_I register

0	1	1	0	1	0	0	1
---	---	---	---	---	---	---	---

9.12 CTRL1_XL (10h)

Linear acceleration sensor control register 1 (r/w).

Table 45. CTRL1_XL register

ODR_XL3	ODR_XL2	ODR_XL1	ODR_XL0	FS_XL1	FS_XL0	BW_XL1	BW_XL0
---------	---------	---------	---------	--------	--------	--------	--------

Table 46. CTRL1_XL register description

ODR_XL [3:0]	Output data rate and power mode selection. Default value: 0000 (see Table 47).
FS_XL [1:0]	Accelerometer full-scale selection. Default value: 00. (00: ± 2 g; 01: ± 16 g; 10: ± 4 g; 11: ± 8 g)
BW_XL [1:0]	Anti-aliasing filter bandwidth selection. Default value: 00 (00: 400 Hz; 01: 200 Hz; 10: 100 Hz; 11: 50 Hz)

Table 47. Accelerometer ODR register setting

ODR_XL3	ODR_XL2	ODR_XL1	ODR_XL0	ODR selection [Hz] when XL_HM_MODE = 1	ODR selection [Hz] when XL_HM_MODE = 0
0	0	0	0	Power-down	Power-down
0	0	0	1	13 Hz (low power)	13 Hz (high performance)
0	0	1	0	26 Hz (low power)	26 Hz (high performance)
0	0	1	1	52 Hz (low power)	52 Hz (high performance)
0	1	0	0	104 Hz (normal mode)	104 Hz (high performance)
0	1	0	1	208 Hz (normal mode)	208 Hz (high performance)
0	1	1	0	416 Hz (high performance)	416 Hz (high performance)
0	1	1	1	833 Hz (high performance)	833 Hz (high performance)
1	0	0	0	1.66 kHz (high performance)	1.66 kHz (high performance)
1	0	0	1	3.33 kHz (high performance)	3.33 kHz (high performance)
1	0	1	0	6.66 kHz (high performance)	6.66 kHz (high performance)

Table 48. BW and ODR (high-performance mode)

ODR ⁽¹⁾	Analog filter BW (XL_HM_MODE = 0)	
	XL_BW_SCAL_ODR = 0	XL_BW_SCAL_ODR = 1
6.66 - 3.33 kHz	Filter not used	Bandwidth is determined by setting BW_XL[1:0] in CTRL1_XL (10h)
1.66 kHz	400 Hz	
833 Hz	400 Hz	
416 Hz	200 Hz	
208 Hz	100 Hz	
104 - 13 Hz	50 Hz	

1. Filter not used when accelerometer is in normal and low-power modes.

9.13 CTRL2_G (11h)

Angular rate sensor control register 2 (r/w).

Table 49. CTRL2_G register

ODR_G3	ODR_G2	ODR_G1	ODR_G0	FS_G1	FS_G0	FS_125	0 ⁽¹⁾
--------	--------	--------	--------	-------	-------	--------	------------------

1. This bit must be set to '0' for the correct operation of the device.

Table 50. CTRL2_G register description

ODR_G [3:0]	Gyroscope output data rate selection. Default value: 0000 (Refer to Table 49)
FS_G [1:0]	Gyroscope full-scale selection. Default value: 00 (00: 245 dps; 01: 500 dps; 10: 1000 dps; 11: 2000 dps)
FS_125	Gyroscope full-scale at 125 dps. Default value: 0 (0: disabled; 1: enabled)

Table 51. Gyroscope ODR configuration setting

ODR_G3	ODR_G2	ODR_G1	ODR_G0	ODR [Hz] when G_HM_MODE = 1	ODR [Hz] when G_HM_MODE = 0
0	0	0	0	Power down	Power down
0	0	0	1	13 Hz (low power)	13 Hz (high performance)
0	0	1	0	26 Hz (low power)	26 Hz (high performance)
0	0	1	1	52 Hz (low power)	52 Hz (high performance)
0	1	0	0	104 Hz (normal mode)	104 Hz (high performance)
0	1	0	1	208 Hz (normal mode)	208 Hz (high performance)
0	1	1	0	416 Hz (high performance)	416 Hz (high performance)
0	1	1	1	833 Hz (high performance)	833 Hz (high performance)
1	0	0	0	1.66 kHz (high performance)	1.66 kHz (high performance)

9.14 CTRL3_C (12h)

Control register 3 (r/w).

Table 52. CTRL3_C register

BOOT	BDU	H_LACTIVE	PP_OD	SIM	IF_INC	BLE	SW_RESET
------	-----	-----------	-------	-----	--------	-----	----------

Table 53. CTRL3_C register description

BOOT	Reboot memory content. Default value: 0 (0: normal mode; 1: reboot memory content ⁽¹⁾)
BDU	Block Data Update. Default value: 0 (0: continuous update; 1: output registers not updated until MSB and LSB have been read)
H_LACTIVE	Interrupt activation level. Default value: 0 (0: interrupt output pads active high; 1: interrupt output pads active low)
PP_OD	Push-pull/open-drain selection on INT1 and INT2 pads. Default value: 0 (0: push-pull mode; 1: open-drain mode)
SIM	SPI Serial Interface Mode selection. Default value: 0 (0: 4-wire interface; 1: 3-wire interface).
IF_INC	Register address automatically incremented during a multiple byte access with a serial interface (I ² C or SPI). Default value: 1 (0: disabled; 1: enabled)
BLE	Big/Little Endian Data selection. Default value 0 (0: data LSB @ lower address; 1: data MSB @ lower address)
SW_RESET	Software reset. Default value: 0 (0: normal mode; 1: reset device) This bit is cleared by hardware after next flash boot.

1. Boot request is executed as soon as internal oscillator is turned on. It is possible to set bit while in power-down mode, in this case it will be served at the next normal mode or sleep mode.

9.15 CTRL4_C (13h)

Control register 4 (r/w).

Table 54. CTRL4_C register

XL_BW_SCAL_ODR	SLEEP_G	INT2_on_INT1	FIFO_TEMP_EN	DRDY_MASK	I2C_disable	3.3kHz_ODR	STOP_ON_FTH
----------------	---------	--------------	--------------	-----------	-------------	------------	-------------

Table 55. CTRL4_C register description

XL_BW_SCAL_ODR	Accelerometer bandwidth selection. Default value: 0 (0 ⁽¹⁾ : bandwidth determined by ODR selection, refer to Table 48 ; 1 ⁽²⁾ : bandwidth determined by setting BW_XL[1:0] in CTRL1_XL (10h) register.)
SLEEP_G	Gyroscope sleep mode enable. Default value: 0 (0: disabled; 1: enabled)
INT2_on_INT1	All interrupt signals available on INT1 pad enable. Default value: 0 (0: interrupt signals divided between INT1 and INT2 pads; 1: all interrupt signals in logic or on INT1 pad)
FIFO_TEMP_EN	Enable temperature data as 4 th FIFO data set ⁽³⁾ . Default: 0 (0: disable temperature data as 4 th FIFO data set; 1: enable temperature data as 4 th FIFO data set)
DRDY_MASK	Configuration 1 ⁽⁴⁾ data available enable bit. Default value: 0 (0: DA timer disabled; 1: DA timer enabled)
I2C_disable	Disable I ² C interface. Default value: 0 (0: both I ² C and SPI enabled; 1: I ² C disabled, SPI only)
3.3kHz_ODR	Enable 3.3 kHz in primary SPI interface. (0: disable; 1: enable 3.3 kHz ODR for gyroscope part with full scale and high-pass filter coherent with control registers setting). ⁽⁵⁾ ⁽⁶⁾
STOP_ON_FTH	Enable FIFO threshold level use. Default value: 0. (0: FIFO depth is not limited; 1: FIFO depth is limited to threshold level)

1. Filter used in high-performance mode only with ODR less than 3.33 kHz.
2. Filter used in high-performance mode only.
3. This bit is effective if the TIMER_PEDO_FIFO_EN bit of FIFO_CTRL2 register is set to 0.
4. In configuration 1, switching to combo mode, data are collected in FIFO only when both accelerometer and gyroscope are set. Switching to accelerometer only, data are collected in FIFO after filter setting.
5. FIFO and gyroscope low-power mode are not supported when this bit is set to '1'.
6. DataReady (pulsed or latched) is available on the INT1/INT2 pins.

9.16 CTRL5_C (14h)

Control register 5 (r/w).

Table 56. CTRL5_C register

ROUNDING2	ROUNDING1	ROUNDING0	0 ⁽¹⁾	ST1_G	ST0_G	ST1_XL	ST0_XL
-----------	-----------	-----------	------------------	-------	-------	--------	--------

1. This bit must be set to '0' for the correct operation of the device

Table 57. CTRL5_C register description

ROUNDING[2:0]	Circular burst-mode (rounding) read from output registers. Default: 000 (000: no rounding; Others: refer to Table 58)
ST_G [1:0]	Angular rate sensor self-test enable. Default value: 00 (00: Self-test disabled; Other: refer to Table 59)
ST_XL [1:0]	Linear acceleration sensor self-test enable. Default value: 00 (00: Self-test disabled; Other: refer to Table 60)

Table 58. Output registers rounding pattern

ROUNDING[2:0]	Rounding pattern
000	No rounding
001	Accelerometer only
010	Gyroscope only
011	Gyroscope + accelerometer
100	Registers from SENSORHUB1_REG (2Eh) to SENSORHUB6_REG (33h) only
101	Accelerometer + registers from SENSORHUB1_REG (2Eh) to SENSORHUB6_REG (33h)
110	Gyroscope + accelerometer + registers from SENSORHUB1_REG (2Eh) to SENSORHUB6_REG (33h) and registers from SENSORHUB7_REG (34h) to SENSORHUB12_REG(39h)
111	Gyroscope + accelerometer + registers from SENSORHUB1_REG (2Eh) to SENSORHUB6_REG (33h)

Table 59. Angular rate sensor self-test mode selection

ST1_G	ST0_G	Self-test mode
0	0	Normal mode
0	1	Positive sign self-test
1	0	Not allowed
1	1	Negative sign self-test

Table 60. Linear acceleration sensor self-test mode selection

ST1_XL	ST0_XL	Self-test mode
0	0	Normal mode
0	1	Positive sign self-test
1	0	Negative sign self-test
1	1	Not allowed

9.17 CTRL6_C (15h)

Angular rate sensor control register 6 (r/w).

Table 61. CTRL6_C register

TRIG_EN	LVLen	LVL2_EN	XL_HM_MODE	0 ⁽¹⁾	0 ⁽¹⁾	0 ⁽¹⁾	0 ⁽¹⁾
---------	-------	---------	------------	------------------	------------------	------------------	------------------

1. This bit must be set to '0' for the correct operation of the device.

Table 62. CTRL6_C register description

TRIG_EN	Gyroscope data edge-sensitive trigger enable. Default value: 0 (0: external trigger disabled; 1: external trigger enabled)
LVLen	Gyroscope data level-sensitive trigger enable. Default value: 0 (0: level-sensitive trigger disabled; 1: level sensitive trigger enabled)
LVL2_EN	Gyroscope level-sensitive latched enable. Default value: 0 (0: level-sensitive latched disabled; 1: level sensitive latched enabled)
XL_HM_MODE	High-performance operating mode disable for accelerometer ⁽¹⁾ . Default value: 0 (0: high-performance operating mode enabled; 1: high-performance operating mode disabled)

1. Normal and low-power mode depends on the ODR setting, for details refer to [Table 47](#).

9.18 CTRL7_G (16h)

Angular rate sensor control register 7 (r/w).

Table 63. CTRL7_G register

G_HM_MODE	HP_G_EN	HPCF_G1	HPCF_G0	HP_G_RST	ROUNDING_STATUS	0 ⁽¹⁾	0 ⁽¹⁾
-----------	---------	---------	---------	----------	-----------------	------------------	------------------

1. This bit must be set to '0' for the correct operation of the device.

Table 64. CTRL7_G register description

G_HM_MODE	High-performance operating mode disable for gyroscope ⁽¹⁾ . Default: 0 (0: high-performance operating mode enabled; 1: high-performance operating mode disabled)
HP_G_EN	Gyroscope high-pass filter enable. Default value: 0 (0: HPF disabled; 1: HPF enabled)
HP_G_RST	Gyro digital HP filter reset. Default: 0 (0: gyro digital HP filter reset OFF; 1: gyro digital HP filter reset ON)
ROUNDING_STATUS	Source register rounding function enable on STATUS_REG/STATUS_SPIAux (1Eh) , FUNC_SRC (53h) and WAKE_UP_SRC (1Bh) registers. Default value: 0 (0: disabled; 1: enabled)
HPCF_G[1:0]	Gyroscope high-pass filter cutoff frequency selection. Default value: 00. Refer to Table 65 .

1. Normal and low-power mode depends on the ODR setting, for details refer to [Table 51](#).

Table 65. Gyroscope high-pass filter mode configuration

HPCF_G1	HPCF_G0	High-pass filter cutoff frequency
0	0	0.0081 Hz
0	1	0.0324 Hz
1	0	2.07 Hz
1	1	16.32 Hz

9.19 CTRL8_XL (17h)

Linear acceleration sensor control register 8 (r/w).

Table 66. CTRL8_XL register

LPF2_XL_EN	HPCF_XL1	HPCF_XL0	0 ⁽¹⁾	0 ⁽¹⁾	HP_SLOPE_XL_EN	0 ⁽¹⁾	LOW_PASS_ON_6D
------------	----------	----------	------------------	------------------	----------------	------------------	----------------

1. This bit must be set to '0' for the correct operation of the device.

Table 67. CTRL8_XL register description

LPF2_XL_EN	Accelerometer low-pass filter LPF2 selection. Refer to Figure 7 .
HPCF_XL[1:0]	Accelerometer slope filter and high-pass filter configuration and cutoff setting. Refer to Table 68 .
HP_SLOPE_XL_EN	Accelerometer slope filter / high-pass filter selection. Refer to Figure 7 .
LOW_PASS_ON_6D	Low-pass filter on 6D function selection. Refer to Figure 7 .

Table 68. Accelerometer slope and high-pass filter selection and cutoff frequency

HPCF_XL[1:0]	Applied filter	HP filter cutoff frequency [Hz]
00	Slope	ODR_XL/4
01	High-pass	ODR_XL/100
10	High-pass	ODR_XL/9
11	High-pass	ODR_XL/400

9.20 CTRL9_XL (18h)

Linear acceleration sensor control register 9 (r/w).

Table 69. CTRL9_XL register

0 ⁽¹⁾	0 ⁽¹⁾	Zen_XL	Yen_XL	Xen_XL	SOFT_EN	0 ⁽¹⁾	0 ⁽¹⁾
------------------	------------------	--------	--------	--------	---------	------------------	------------------

1. This bit must be set to '0' for the correct operation of the device.

Table 70. CTRL9_XL register description

Zen_XL	Accelerometer Z-axis output enable. Default value: 1 (0: Z-axis output disabled; 1: Z-axis output enabled)
Yen_XL	Accelerometer Y-axis output enable. Default value: 1 (0: Y-axis output disabled; 1: Y-axis output enabled)
Xen_XL	Accelerometer X-axis output enable. Default value: 1 (0: X-axis output disabled; 1: X-axis output enabled)
SOFT_EN	Enable soft-iron correction algorithm for magnetometer ⁽¹⁾ . Default value: 0 (0: soft-iron correction algorithm disabled; 1: soft-iron correction algorithm disabled)

1. This bit is effective if the IRON_EN bit of MASTER_CONFIG (1Ah) is set to 1.

9.21 CTRL10_C (19h)

Control register 10 (r/w).

Table 71. CTRL10_C register

0 ⁽¹⁾	0 ⁽¹⁾	Zen_G	Yen_G	Xen_G	FUNC_EN	PEDO_RST_STEP	SIGN_MOTION_EN
------------------	------------------	-------	-------	-------	---------	---------------	----------------

1. This bit must be set to '0' for the correct operation of the device.

Table 72. CTRL10_C register description

Zen_G	Gyroscope yaw axis (Z) output enable. Default value: 1 (0: Z-axis output disabled; 1: Z-axis output enabled)
Yen_G	Gyroscope roll axis (Y) output enable. Default value: 1 (0: Y-axis output disabled; 1: Y axis output enabled)
Xen_G	Gyroscope pitch axis (X) output enable. Default value: 1 (0: X-axis output disabled; 1: X-axis output enabled)
FUNC_EN	Enable embedded functionalities (pedometer, tilt, significant motion, sensor hub and ironing) and accelerometer HP and LPF2 filters (refer to Figure 7). Default value: 0 (0: disable functionalities of embedded functions and accelerometer filters; 1: enable functionalities of embedded functions and accelerometer filters)
PEDO_RST_STEP	Reset pedometer step counter. Default value: 0 (0: disabled; 1: enabled)
SIGN_MOTION_EN	Enable significant motion function. Default value: 0 (0: disabled; 1: enabled)

9.22 MASTER_CONFIG (1Ah)

Master configuration register (r/w).

Table 73. MASTER_CONFIG register

DRDY_ON_INT1	DATA_VALID_SEL_FIFO	0 ⁽¹⁾	START_CONFIG	PULL_UP_EN	PASS_THROUGH_MODE	IRON_EN	MASTER_ON
--------------	---------------------	------------------	--------------	------------	-------------------	---------	-----------

1. This bit must be set to '0' for the correct operation of the device.

Table 74. MASTER_CONFIG register description

DRDY_ON_INT1	Manage the Master DRDY signal on INT1 pad. Default: 0 (0: disable Master DRDY on INT1; 1: enable Master DRDY on INT1)
DATA_VALID_SEL_FIFO	Selection of FIFO data-valid signal. Default value: 0 (0: data-valid signal used to write data in FIFO is the XL/Gyro data-ready or step detection ⁽¹⁾ ; 1: data-valid signal used to write data in FIFO is the sensor hub data-ready)
START_CONFIG	Sensor Hub trigger signal selection. Default value: 0 (0: Sensor hub signal is the XL/Gyro data-ready; 1: Sensor hub signal external from INT2 pad.)
PULL_UP_EN	Auxiliary I ² C pull-up. Default value: 0 (0: internal pull-up on auxiliary I ² C line disabled; 1: internal pull-up on auxiliary I ² C line enabled)
PASS_THROUGH_MODE	I ² C interface pass-through. Default value: 0 (0: through disabled; 1: through enabled)
IRON_EN	Enable hard-iron correction algorithm for magnetometer. Default value: 0 (0: hard-iron correction algorithm disabled; 1: hard-iron correction algorithm enabled)
MASTER_ON	Sensor hub I ² C master enable. Default: 0 (0: master I ² C of sensor hub disabled; 1: master I ² C of sensor hub enabled)

1. If the TIMER_PEDO_FIFO_DRDY bit in FIFO_CTRL2(07h) is set to 0, the trigger for writing data in FIFO is XL/Gyro data-ready, otherwise it's the step detection.

9.23 WAKE_UP_SRC (1Bh)

Wake up interrupt source register (r).

Table 75. WAKE_UP_SRC register

0 ⁽¹⁾	0 ⁽¹⁾	FF_IA	SLEEP_STATE_IA	WU_IA	X_WU	Y_WU	Z_WU
------------------	------------------	-------	----------------	-------	------	------	------

1. This bit must be set to '0' for the correct operation of the device.

Table 76. WAKE_UP_SRC register description

FF_IA	Free-fall event detection status. Default: 0 (0: free-fall event not detected; 1: free-fall event detected)
SLEEP_STATE_IA	Sleep event status. Default value: 0 (0: sleep event not detected; 1: sleep event detected)
WU_IA	Wakeup event detection status. Default value: 0 (0: wakeup event not detected; 1: wakeup event detected.)
X_WU	Wakeup event detection status on X-axis. Default value: 0 (0: wakeup event on X-axis not detected; 1: wakeup event on X-axis detected)
Y_WU	Wakeup event detection status on Y-axis. Default value: 0 (0: wakeup event on Y-axis not detected; 1: wakeup event on Y-axis detected)
Z_WU	Wakeup event detection status on Z-axis. Default value: 0 (0: wakeup event on Z-axis not detected; 1: wakeup event on Z-axis detected)

9.24 TAP_SRC (1Ch)

Tap source register (r).

Table 77. TAP_SRC register

0 ⁽¹⁾	TAP_IA	SINGLE_TAP	DOUBLE_TAP	TAP_SIGN	X_TAP	Y_TAP	Z_TAP
------------------	--------	------------	------------	----------	-------	-------	-------

1. This bit must be set to '0' for the correct operation of the device.

Table 78. TAP_SRC register description

TAP_IA	Tap event detection status. Default: 0 (0: tap event not detected; 1: tap event detected)
SINGLE_TAP	Single-tap event status. Default value: 0 (0: single tap event not detected; 1: single tap event detected)
DOUBLE_TAP	Double-tap event detection status. Default value: 0 (0: double-tap event not detected; 1: double-tap event detected.)
TAP_SIGN	Sign of acceleration detected by tap event. Default: 0 (0: positive sign of acceleration detected by tap event; 1: negative sign of acceleration detected by tap event)
X_TAP	Tap event detection status on X-axis. Default value: 0 (0: tap event on X-axis not detected; 1: tap event on X-axis detected)
Y_TAP	Tap event detection status on Y-axis. Default value: 0 (0: tap event on Y-axis not detected; 1: tap event on Y-axis detected)
Z_TAP	Tap event detection status on Z-axis. Default value: 0 (0: tap event on Z-axis not detected; 1: tap event on Z-axis detected)

9.25 D6D_SRC (1Dh)

Portrait, landscape, face-up and face-down source register (r)

Table 79. D6D_SRC register

0 ⁽¹⁾	D6D_IA	ZH	ZL	YH	YL	XH	XL
------------------	--------	----	----	----	----	----	----

1. This bit must be set to '0' for the correct operation of the device.

Table 80. D6D_SRC register description

D6D_IA	Interrupt active for change position portrait, landscape, face-up, face-down. Default value: 0 (0: change position not detected; 1: change position detected)
ZH	Z-axis high event (over threshold). Default value: 0 (0: event not detected; 1: event (over threshold) detected)
ZL	Z-axis low event (under threshold). Default value: 0 (0: event not detected; 1: event (under threshold) detected)
YH	Y-axis high event (over threshold). Default value: 0 (0: event not detected; 1: event (over-threshold) detected)
YL	Y-axis low event (under threshold). Default value: 0 (0: event not detected; 1: event (under threshold) detected)
X_H	X-axis high event (over threshold). Default value: 0 (0: event not detected; 1: event (over threshold) detected)
X_L	X-axis low event (under threshold). Default value: 0 (0: event not detected; 1: event (under threshold) detected)

9.26 STATUS_REG/STATUS_SPIAux (1Eh)

The STATUS_REG register is read by the primary interface SPI/I²C.

Table 81. STATUS_REG register

0	0	0	0	0	TDA	GDA	XLDA
---	---	---	---	---	-----	-----	------

Table 82. STATUS_REG register description

TDA	Temperature new data available. Default: 0 (0: no set of data is available at temperature sensor output; 1: a new set of data is available at temperature sensor output)
GDA	Gyroscope new data available. Default value: 0 (0: no set of data available at gyroscope output; 1: a new set of data is available at gyroscope output)
XLDA	Accelerometer new data available. Default value: 0 (0: no set of data available at accelerometer output; 1: a new set of data is available at accelerometer output)

The STATUS_SPIAux register is read by the auxiliary SPI.

Table 83. STATUS_SPIAux register

0	0	0	0	0	GYRO_SETTING	GDA	0
---	---	---	---	---	--------------	-----	---

Table 84. STATUS_SPIAux description

GYRO_SETTING	High when the gyroscope output is in the setting phase
GDA	Gyroscope data available (reset when one of the high parts of output data is read)

9.27 OUT_TEMP_L (20h), OUT_TEMP (21h)

Temperature data output register (r). L and H registers together express a 16-bit word in two's complement (r).

Table 85. OUT_TEMP_L register

Temp7	Temp6	Temp5	Temp4	Temp3	Temp2	Temp1	Temp0
-------	-------	-------	-------	-------	-------	-------	-------

Table 86. OUT_TEMP_H register

Temp15	Temp14	Temp13	Temp12	Temp11	Temp10	Temp9	Temp8
--------	--------	--------	--------	--------	--------	-------	-------

Table 87. OUT_TEMP register description

Temp[15:0]	Temperature sensor output data The value is expressed as two's complement sign extended on the MSB.
------------	--

9.28 OUTX_L_G (22h)

Angular rate sensor pitch axis (X) angular rate output register (r). The value is expressed as a 16-bit word in two's complement. (r)

If this register is read by the primary interface, data are according to the full scale and ODR settings (*CTRL2_G (11h)*) of gyro user interface.

If this register is read by the auxiliary interface, data are according to the full scale (250 dps) and ODR (3.33 kHz) settings of the OIS gyro.

Table 88. OUTX_L_G register

D7	D6	D5	D4	D3	D2	D1	D0
----	----	----	----	----	----	----	----

Table 89. OUTX_L_G register description

D[7:0]	Pitch axis (X) angular rate value (LSbyte) D[15:0] expressed in two's complement and its value depends on the interface used: SPI1/I ² C: Gyro UI chain pitch axis output SPI2: Gyro OIS chain pitch axis output
--------	--

9.29 OUTX_H_G (23h)

Angular rate sensor pitch axis (X) angular rate output register (r). The value is expressed as a 16-bit word in two's complement. (r)

If this register is read by the primary interface, data are according to the full scale and ODR settings (*CTRL2_G (11h)*) of gyro user interface.

If this register is read by the auxiliary interface, data are according to the full scale (250 dps) and ODR (3.33 kHz) settings of the OIS gyro.

Table 90. OUTX_H_G register

D15	D14	D13	D12	D11	D10	D9	D8
-----	-----	-----	-----	-----	-----	----	----

Table 91. OUTX_H_G register description

D[15:8]	Pitch axis (X) angular rate value (MSbyte) D[15:0] expressed in two's complement and its value depends on the interface used: SPI1/I ² C: Gyro UI chain pitch axis output SPI2: Gyro OIS chain pitch axis output
---------	--

9.30 OUTY_L_G (24h)

Angular rate sensor roll axis (Y) angular rate output register (r). The value is expressed as a 16-bit word in two's complement. (r).

If this register is read by the primary interface, data are according to the full scale and ODR settings (*CTRL2_G (11h)*) of gyro user interface.

If this register is read by the auxiliary interface, data are according to the full scale (250 dps) and ODR (3.33 kHz) settings of the OIS gyro.

Table 92. OUTY_L_G register

D7	D6	D5	D4	D3	D2	D1	D0
----	----	----	----	----	----	----	----

Table 93. OUTY_L_G register description

D[7:0]	Roll axis (Y) angular rate value (LSbyte) D[15:0] expressed in two's complement and its value depends on the interface used: SPI1/I ² C: Gyro UI chain roll axis output SPI2: Gyro OIS chain roll axis output
--------	---

9.31 OUTY_H_G (25h)

Angular rate sensor roll axis (Y) angular rate output register (r). The value is expressed as a 16-bit word in two's complement. (r).

If this register is read by the primary interface, data are according to the full scale and ODR settings (*CTRL2_G (11h)*) of gyro user interface.

If this register is read by the auxiliary interface, data are according to the full scale (250 dps) and ODR (3.33 kHz) settings of the OIS gyro.

Table 94. OUTY_H_G register

D15	D14	D13	D12	D11	D10	D9	D8
-----	-----	-----	-----	-----	-----	----	----

Table 95. OUTY_H_G register description

D[15:8]	Roll axis (Y) angular rate value (MSbyte) D[15:0] expressed in two's complement and its value depends on the interface used: SPI1/I ² C: Gyro UI chain roll axis output SPI2: Gyro OIS chain roll axis output
---------	---

9.32 OUTZ_L_G (26h)

Angular rate sensor yaw axis (Z) angular rate output register (r). The value is expressed as a 16-bit word in two's complement. (r).

If this register is read by the primary interface, data are according to the full scale and ODR settings (*CTRL2_G (11h)*) of gyro user interface.

If this register is read by the auxiliary interface, data are according to the full scale (250 dps) and ODR (3.33 kHz) settings of the OIS gyro.

Table 96. OUTZ_L_G register

D7	D6	D5	D4	D3	D2	D1	D0
----	----	----	----	----	----	----	----

Table 97. OUTZ_L_G register description

D[7:0]	Yaw axis (Z) angular rate value (LSbyte) D[15:0] expressed in two's complement and its value depends on the interface used: SPI1/I ² C: Gyro UI chain yaw axis output SPI2: Gyro OIS chain yaw axis output
--------	--

9.33 OUTZ_H_G (27h)

Angular rate sensor Yaw axis (Z) angular rate output register (r). The value is expressed as a 16-bit word in two's complement.

If this register is read by the primary interface, data are according to the full scale and ODR settings (*CTRL2_G (11h)*) of gyro user interface.

If this register is read by the auxiliary interface, data are according to the full scale (250 dps) and ODR (3.33 kHz) settings of the OIS gyro.

Table 98. OUTZ_H_G register

D15	D14	D13	D12	D11	D10	D9	D8
-----	-----	-----	-----	-----	-----	----	----

Table 99. OUTZ_H_G register description

D[15:8]	Yaw axis (Z) angular rate value (MSbyte) D[15:0] expressed in two's complement and its value depends on the interface used: SPI1/I ² C: Gyro UI chain yaw axis output SPI2: Gyro OIS chain yaw axis output
---------	--

9.34 OUTX_L_XL (28h)

Linear acceleration sensor X-axis output register (r). The value is expressed as a 16-bit word in two's complement.

Table 100. OUTX_L_XL register

D7	D6	D5	D4	D3	D2	D1	D0
----	----	----	----	----	----	----	----

Table 101. OUTX_L_XL register description

D[7:0]	X-axis linear acceleration value (LSbyte)
--------	---

9.35 OUTX_H_XL (29h)

Linear acceleration sensor X-axis output register (r). The value is expressed as a 16-bit word in two's complement.

Table 102. OUTX_H_XL register

D15	D14	D13	D12	D11	D10	D9	D8
-----	-----	-----	-----	-----	-----	----	----

Table 103. OUTX_H_XL register description

D[15:8]	X-axis linear acceleration value (MSbyte)
---------	---

9.36 OUTY_L_XL (2Ah)

Linear acceleration sensor Y-axis output register (r). The value is expressed as a 16-bit word in two's complement.

Table 104. OUTY_L_XL register

D7	D6	D5	D4	D3	D2	D1	D0
----	----	----	----	----	----	----	----

Table 105. OUTY_L_XL register description

D[7:0]	Y-axis linear acceleration value (LSbyte)
--------	---

9.37 OUTY_H_XL (2Bh)

Linear acceleration sensor Y-axis output register (r). The value is expressed as a 16-bit word in two's complement.

Table 106. OUTY_H_G register

D15	D14	D13	D12	D11	D10	D9	D8
-----	-----	-----	-----	-----	-----	----	----

Table 107. OUTY_H_G register description

D[15:8]	Y-axis linear acceleration value (MSbyte)
---------	---

9.38 OUTZ_L_XL (2Ch)

Linear acceleration sensor Z-axis output register (r). The value is expressed as a 16-bit word in two's complement.

Table 108. OUTZ_L_XL register

D7	D6	D5	D4	D3	D2	D1	D0
----	----	----	----	----	----	----	----

Table 109. OUTZ_L_XL register description

D[7:0]	Z-axis linear acceleration value (LSbyte)
--------	---

9.39 OUTZ_H_XL (2Dh)

Linear acceleration sensor Z-axis output register (r). The value is expressed as a 16-bit word in two's complement.

Table 110. OUTZ_H_XL register

D15	D14	D13	D12	D11	D10	D9	D8
-----	-----	-----	-----	-----	-----	----	----

Table 111. OUTZ_H_XL register description

D[15:8]	Z-axis linear acceleration value (MSbyte)
---------	---

9.40 SENSORHUB1_REG (2Eh)

First byte associated to external sensors. The content of the register is consistent with the SLAVEx_CONFIG number of read operation configurations (for external sensors from x = 0 to x = 3).

Table 112. SENSORHUB1_REG register

SHub1_7	SHub1_6	SHub1_5	SHub1_4	SHub1_3	SHub1_2	SHub1_1	SHub1_0
---------	---------	---------	---------	---------	---------	---------	---------

Table 113. SENSORHUB1_REG register description

SHub1_[7:0]	First byte associated to external sensors
-------------	---

9.41 SENSORHUB2_REG (2Fh)

Second byte associated to external sensors. The content of the register is consistent with the SLAVEx_CONFIG number of read operations configurations (for external sensors from x = 0 to x = 3).

Table 114. SENSORHUB2_REG register

SHub2_7	SHub2_6	SHub2_5	SHub2_4	SHub2_3	SHub2_2	SHub2_1	SHub2_0
---------	---------	---------	---------	---------	---------	---------	---------

Table 115. SENSORHUB2_REG register description

SHub2_[7:0]	Second byte associated to external sensors
-------------	--

9.42 SENSORHUB3_REG (30h)

Third byte associated to external sensors. The content of the register is consistent with the SLAVEx_CONFIG number of read operations configurations (for external sensors from x = 0 to x = 3).

Table 116. SENSORHUB3_REG register

SHub3_7	SHub3_6	SHub3_5	SHub3_4	SHub3_3	SHub3_2	SHub3_1	SHub3_0
---------	---------	---------	---------	---------	---------	---------	---------

Table 117. SENSORHUB3_REG register description

SHub3_[7:0]	Third byte associated to external sensors
-------------	---

9.43 SENSORHUB4_REG (31h)

Fourth byte associated to external sensors. The content of the register is consistent with the SLAVEx_CONFIG number of read operation configurations (for external sensors from x = 0 to x = 3).

Table 118. SENSORHUB4_REG register

SHub4_7	SHub4_6	SHub4_5	SHub4_4	SHub4_3	SHub4_2	SHub4_1	SHub4_0
---------	---------	---------	---------	---------	---------	---------	---------

Table 119. SENSORHUB4_REG register description

SHub4_[7:0]	Fourth byte associated to external sensors
-------------	--

9.44 SENSORHUB5_REG (32h)

Fifth byte associated to external sensors. The content of the register is consistent with the SLAVEx_CONFIG number of read operation configurations (for external sensors from x = 0 to x = 3).

Table 120. SENSORHUB5_REG register

SHub5_7	SHub5_6	SHub5_5	SHub5_4	SHub5_3	SHub5_2	SHub5_1	SHub5_0
---------	---------	---------	---------	---------	---------	---------	---------

Table 121. SENSORHUB5_REG register description

SHub5_[7:0]	Fifth byte associated to external sensors
-------------	---

9.45 SENSORHUB6_REG (33h)

Sixth byte associated to external sensors. The content of the register is consistent with the SLAVEx_CONFIG number of read operation configurations (for external sensors from x = 0 to x = 3).

Table 122. SENSORHUB6_REG register

SHub6_7	SHub6_6	SHub6_5	SHub6_4	SHub6_3	SHub6_2	SHub6_1	SHub6_0
---------	---------	---------	---------	---------	---------	---------	---------

Table 123. SENSORHUB6_REG register description

SHub6_[7:0]	Sixth byte associated to external sensors
-------------	---

9.46 SENSORHUB7_REG (34h)

Seventh byte associated to external sensors. The content of the register is consistent with the SLAVEx_CONFIG number of read operation configurations (for external sensors from x = 0 to x = 3).

Table 124. SENSORHUB7_REG register

SHub7_7	SHub7_6	SHub7_5	SHub7_4	SHub7_3	SHub7_2	SHub7_1	SHub7_0
---------	---------	---------	---------	---------	---------	---------	---------

Table 125. SENSORHUB7_REG register description

SHub7_[7:0]	Seventh byte associated to external sensors
-------------	---

9.47 SENSORHUB8_REG(35h)

Eighth byte associated to external sensors. The content of the register is consistent with the SLAVEx_CONFIG number of read operation configurations (for external sensors from x = 0 to x = 3).

Table 126. SENSORHUB8_REG register

SHub8_7	SHub8_6	SHub8_5	SHub8_4	SHub8_3	SHub8_2	SHub8_1	SHub8_0
---------	---------	---------	---------	---------	---------	---------	---------

Table 127. SENSORHUB8_REG register description

SHub8_[7:0]	Eighth byte associated to external sensors
-------------	--

9.48 SENSORHUB9_REG (36h)

Ninth byte associated to external sensors. The content of the register is consistent with the SLAVEx_CONFIG number of read operation configurations (for external sensors from x = 0 to x = 3).

Table 128. SENSORHUB9_REG register

SHub9_7	SHub9_6	SHub9_5	SHub9_4	SHub9_3	SHub9_2	SHub9_1	SHub9_0
---------	---------	---------	---------	---------	---------	---------	---------

Table 129. SENSORHUB9_REG register description

SHub9_[7:0]	Ninth byte associated to external sensors
-------------	---

9.49 SENSORHUB10_REG (37h)

Tenth byte associated to external sensors. The content of the register is consistent with the SLAVEx_CONFIG number of read operation configurations (for external sensors from x = 0 to x = 3).

Table 130. SENSORHUB10_REG register

SHub10_7	SHub10_6	SHub10_5	SHub10_4	SHub10_3	SHub10_2	SHub10_1	SHub10_0
----------	----------	----------	----------	----------	----------	----------	----------

Table 131. SENSORHUB10_REG register description

SHub10_[7:0]	Tenth byte associated to external sensors
--------------	---

9.50 SENSORHUB11_REG (38h)

Eleventh byte associated to external sensors. The content of the register is consistent with the SLAVEx_CONFIG number of read operation configurations (for external sensors from x = 0 to x = 3).

Table 132. SENSORHUB11_REG register

SHub11_7	SHub11_6	SHub11_5	SHub11_4	SHub11_3	SHub11_2	SHub11_1	SHub11_0
----------	----------	----------	----------	----------	----------	----------	----------

Table 133. SENSORHUB11_REG register description

SHub11_[7:0]	Eleventh byte associated to external sensors
--------------	--

9.51 SENSORHUB12_REG(39h)

Twelfth byte associated to external sensors. The content of the register is consistent with the SLAVEx_CONFIG number of read operation configurations (for external sensors from x = 0 to x = 3).

Table 134. SENSORHUB12_REG register

SHub12_7	SHub12_6	SHub12_5	SHub12_4	SHub12_3	SHub12_2	SHub12_1	SHub12_0
----------	----------	----------	----------	----------	----------	----------	----------

Table 135. SENSORHUB12_REG register description

SHub12[7:0]	Twelfth byte associated to external sensors
-------------	---

9.52 FIFO_STATUS1 (3Ah)

FIFO status control register (r). For a proper reading of the register it is suggested to set BDU bit in *CTRL3_C (12h)* to 0.

Table 136. FIFO_STATUS1 register

DIFF_FIF0_7	DIFF_FIF0_6	DIFF_FIF0_5	DIFF_FIF0_4	DIFF_FIF0_3	DIFF_FIF0_2	DIFF_FIF0_1	DIFF_FIF0_0
-------------	-------------	-------------	-------------	-------------	-------------	-------------	-------------

Table 137. FIFO_STATUS1 register description

DIFF_FIF0_[7:0]	Number of unread words (16-bit axes) stored in FIFO ⁽¹⁾ .
-----------------	--

1. For a complete number of unread samples, consider DIFF_FIF0 [11:8] in *FIFO_STATUS2 (3Bh)*

9.53 FIFO_STATUS2 (3Bh)

FIFO status control register (r). For a proper reading of the register it is recommended to set the BDU bit in *CTRL3_C (12h)* to 0.

Table 138. FIFO_STATUS2 register

FTH	FIFO_OVER_RUN	FIFO_FULL	FIFO_EMPTY	DIFF_FIF0_11	DIFF_FIF0_10	DIFF_FIF0_9	DIFF_FIF0_8
-----	---------------	-----------	------------	--------------	--------------	-------------	-------------

Table 139. FIFO_STATUS2 register description

FTH	FIFO watermark status. Default value: 0 (0: FIFO filling is lower than watermark level ⁽¹⁾ ; 1: FIFO filling is equal to or higher than the watermark level)
FIFO_OVER_RUN	FIFO overrun status. Default value: 0 (0: FIFO is not completely filled; 1: FIFO is completely filled)
FIFO_FULL	FIFO full status. Default value: 0 (0: FIFO is not full; 1: FIFO will be full at the next ODR)
FIFO_EMPTY	FIFO empty bit. Default value: 0 (0: FIFO contains data; 1: FIFO is empty)
DIFF_FIF0_[7:0]	Number of unread words (16-bit axes) stored in FIFO ⁽²⁾ .

1. FIFO watermark level is set in FTH_[11:0] in *FIFO_CTRL1 (06h)* and *FIFO_CTRL2 (07h)*

2. For a complete number of unread samples, consider DIFF_FIF0 [11:8] in *FIFO_STATUS1 (3Ah)*

9.54 FIFO_STATUS3 (3Ch)

FIFO status control register (r). For a proper reading of the register it is recommended to set the BDU bit in *CTRL3_C (12h)* to 0.

Table 140. FIFO_STATUS3 register

FIFO_PATTERN_7	FIFO_PATTERN_6	FIFO_PATTERN_5	FIFO_PATTERN_4	FIFO_PATTERN_3	FIFO_PATTERN_2	FIFO_PATTERN_1	FIFO_PATTERN_0
----------------	----------------	----------------	----------------	----------------	----------------	----------------	----------------

Table 141. FIFO_STATUS3 register description

FIFO_PATTERN_[7:0]	Word of recursive pattern read at the next reading.
--------------------	---

9.55 FIFO_STATUS4 (3Dh)

FIFO status control register (r). For a proper reading of the register it is recommended to set the BDU bit in CTRL3_C (12h) to 0.

Table 142. FIFO_STATUS4 register

0 ⁽¹⁾	0 ⁽¹⁾	0 ⁽¹⁾	0 ⁽¹⁾	0 ⁽¹⁾	0 ⁽¹⁾	FIFO_PATTERN_9	FIFO_PATTERN_8
------------------	------------------	------------------	------------------	------------------	------------------	----------------	----------------

1. This bit must be set to '0' for the correct operation of the device.

Table 143. FIFO_STATUS4 register description

FIFO_PATTERN_[9:8]	Word of recursive pattern read at the next reading.
--------------------	---

9.56 FIFO_DATA_OUT_L (3Eh)

FIFO data output register (r). For a proper reading of the register it is recommended to set the BDU bit in CTRL3_C (12h) to 0.

Table 144. FIFO_DATA_OUT_L register

DATA_OUT_FIFO_L_7	DATA_OUT_FIFO_L_6	DATA_OUT_FIFO_L_5	DATA_OUT_FIFO_L_4	DATA_OUT_FIFO_L_3	DATA_OUT_FIFO_L_2	DATA_OUT_FIFO_L_1	DATA_OUT_FIFO_L_0
-------------------	-------------------	-------------------	-------------------	-------------------	-------------------	-------------------	-------------------

Table 145. FIFO_DATA_OUT_L register description

DATA_OUT_FIFO_L_[7:0]	FIFO data output (first byte)
-----------------------	-------------------------------

9.57 FIFO_DATA_OUT_H (3Fh)

FIFO data output register (r). For a proper reading of the register it is suggested to set BDU bit in [CTRL3_C \(12h\)](#) to 0.

Table 146. FIFO_DATA_OUT_H register

DATA_	DATA_	DATA_	DATA_	DATA_	DATA_	DATA_	DATA_
OUT_	OUT_	OUT_	OUT_	OUT_	OUT_	OUT_	OUT_
FIFO_H_7	FIFO_H_6	FIFO_H_5	FIFO_H_4	FIFO_H_3	FIFO_H_2	FIFO_H_1	FIFO_H_0

Table 147. FIFO_DATA_OUT_H register description

DATA_OUT_FIFO_H_[7:0]	FIFO data output (second byte)
-----------------------	--------------------------------

9.58 TIMESTAMP0_REG (40h)

Time stamp first byte data output register (r). The value is expressed as a 24-bit word and the bit resolution is defined by setting the value in [WAKE_UP_DUR \(5Ch\)](#).

Table 148. TIMESTAMP0_REG register

TIMESTA	TIMESTA	TIMESTA	TIMESTA	TIMESTA	TIMESTA	TIMESTA	TIMESTA
MP0_7	MP0_6	MP0_5	MP0_4	MP0_3	MP0_2	MP0_1	MP0_0

Table 149. TIMESTAMP0_REG register description

TIMESTAMP0_[7:0]	TIMESTAMP first byte data output
------------------	----------------------------------

9.59 TIMESTAMP1_REG (41h)

Time stamp second byte data output register (r). The value is expressed as a 24-bit word and the bit resolution is defined by setting value in [WAKE_UP_DUR \(5Ch\)](#).

Table 150. TIMESTAMP1_REG register

TIMESTA	TIMESTA	TIMESTA	TIMESTA	TIMESTA	TIMESTA	TIMESTA	TIMESTA
MP1_7	MP1_6	MP1_5	MP1_4	MP1_3	MP1_2	MP1_1	MP1_0

Table 151. TIMESTAMP1_REG register description

TIMESTAMP1_[7:0]	TIMESTAMP second byte data output
------------------	-----------------------------------

9.60 TIMESTAMP2_REG (42h)

Time stamp third byte data output register (r/w). The value is expressed as a 24-bit word and the bit resolution is defined by setting the value in [WAKE_UP_DUR \(5Ch\)](#). To reset the timer, the AAh value has to be stored in this register.

Table 152. TIMESTAMP2_REG register

TIMESTA	TIMESTA	TIMESTA	TIMESTA	TIMESTA	TIMESTA	TIMESTA	TIMESTA
MP2_7	MP2_6	MP2_5	MP2_4	MP2_3	MP2_2	MP2_1	MP2_0

Table 153. TIMESTAMP2_REG register description

TIMESTAMP2_[7:0]	TIMESTAMP third byte data output
------------------	----------------------------------

9.61 STEP_TIMESTAMP_L (49h)

Step counter timestamp information register (r). When a step is detected, the value of TIMESTAMP_REG1 register is copied in STEP_TIMESTAMP_L.

Table 154. STEP_TIMESTAMP_L register

STEP_TIMESTAMP_L_7	STEP_TIMESTAMP_L_6	STEP_TIMESTAMP_L_5	STEP_TIMESTAMP_L_4	STEP_TIMESTAMP_L_3	STEP_TIMESTAMP_L_2	STEP_TIMESTAMP_L_1	STEP_TIMESTAMP_L_0
--------------------	--------------------	--------------------	--------------------	--------------------	--------------------	--------------------	--------------------

Table 155. STEP_TIMESTAMP_L register description

STEP_TIMESTAMP_L[7:0]	Timestamp of last step detected.
-----------------------	----------------------------------

9.62 STEP_TIMESTAMP_H (4Ah)

Step counter timestamp information register (r). When a step is detected, the value of TIMESTAMP_REG2 register is copied in STEP_TIMESTAMP_H.

Table 156. STEP_TIMESTAMP_H register

STEP_TIMESTAMP_H_7	STEP_TIMESTAMP_H_6	STEP_TIMESTAMP_H_5	STEP_TIMESTAMP_H_4	STEP_TIMESTAMP_H_3	STEP_TIMESTAMP_H_2	STEP_TIMESTAMP_H_1	STEP_TIMESTAMP_H_0
--------------------	--------------------	--------------------	--------------------	--------------------	--------------------	--------------------	--------------------

Table 157. STEP_TIMESTAMP_H register description

STEP_TIMESTAMP_H[7:0]	Timestamp of last step detected.
-----------------------	----------------------------------

9.63 STEP_COUNTER_L (4Bh)

Step counter output register (r).

Table 158. STEP_COUNTER_L register

STEP_COUNTER_L_7	STEP_COUNTER_L_6	STEP_COUNTER_L_5	STEP_COUNTER_L_4	STEP_COUNTER_L_3	STEP_COUNTER_L_2	STEP_COUNTER_L_1	STEP_COUNTER_L_0
------------------	------------------	------------------	------------------	------------------	------------------	------------------	------------------

Table 159. STEP_COUNTER_L register description

STEP_COUNTER_L[7:0]	Step counter output (LSbyte)
---------------------	------------------------------

9.64 STEP_COUNTER_H (4Ch)

Step counter output register (r).

Table 160. STEP_COUNTER_H register

STEP_COUNTER_H_7	STEP_COUNTER_H_6	STEP_COUNTER_H_5	STEP_COUNTER_H_4	STEP_COUNTER_H_3	STEP_COUNTER_H_2	STEP_COUNTER_H_1	STEP_COUNTER_H_0
------------------	------------------	------------------	------------------	------------------	------------------	------------------	------------------

Table 161. STEP_COUNTER_H register description

STEP_COUNTER_H[7:0]	Step counter output (MSbyte)
---------------------	------------------------------

9.65 SENSORHUB13_REG (4Dh)

Thirteenth byte associated to external sensors. The content of the register is consistent with the SLAVEx_CONFIG number of read operation configurations (for external sensors from x = 0 to x = 3).

Table 162. SENSORHUB13_REG register

SHub13_7	SHub13_6	SHub13_5	SHub13_4	SHub13_3	SHub13_2	SHub13_1	SHub13_0
----------	----------	----------	----------	----------	----------	----------	----------

Table 163. SENSORHUB13_REG register description

SHub13_[7:0]	Thirteenth byte associated to external sensors
--------------	--

9.66 SENSORHUB14_REG (4Eh)

Fourteenth byte associated to external sensors. The content of the register is consistent with the SLAVEx_CONFIG number of read operation configurations (for external sensors from x = 0 to x = 3).

Table 164. SENSORHUB14_REG register

SHub14_7	SHub14_6	SHub14_5	SHub14_4	SHub14_3	SHub14_2	SHub14_1	SHub14_0
----------	----------	----------	----------	----------	----------	----------	----------

Table 165. SENSORHUB14_REG register description

SHub14_[7:0]	Fourteenth byte associated to external sensors
--------------	--

9.67 SENSORHUB15_REG (4Fh)

Fifteenth byte associated to external sensors. The content of the register is consistent with the SLAVEx_CONFIG number of read operation configurations (for external sensors from x = 0 to x = 3).

Table 166. SENSORHUB15_REG register

SHub15_7	SHub15_6	SHub15_5	SHub15_4	SHub15_3	SHub15_2	SHub15_1	SHub15_0
----------	----------	----------	----------	----------	----------	----------	----------

Table 167. SENSORHUB15_REG register description

SHub15_[7:0]	Fifteenth byte associated to external sensors
--------------	---

9.68 SENSORHUB16_REG (50h)

Sixteenth byte associated to external sensors. The content of the register is consistent with the SLAVEx_CONFIG number of read operation configurations (for external sensors from x = 0 to x = 3).

Table 168. SENSORHUB16_REG register

SHub16_7	SHub16_6	SHub16_5	SHub16_4	SHub16_3	SHub16_2	SHub16_1	SHub16_0
----------	----------	----------	----------	----------	----------	----------	----------

Table 169. SENSORHUB16_REG register description

SHub16_[7:0]	Sixteenth byte associated to external sensors
--------------	---

9.69 SENSORHUB17_REG (51h)

Seventeenth byte associated to external sensors. The content of the register is consistent with the SLAVEx_CONFIG number of read operation configurations (for external sensors from x = 0 to x = 3).

Table 170. SENSORHUB17_REG register

SHub17_7	SHub17_6	SHub17_5	SHub17_4	SHub17_3	SHub17_2	SHub17_1	SHub17_0
----------	----------	----------	----------	----------	----------	----------	----------

Table 171. SENSORHUB17_REG register description

SHub17_[7:0]	Seventeenth byte associated to external sensors
--------------	---

9.70 SENSORHUB18_REG (52h)

Eighteenth byte associated to external sensors. The content of the register is consistent with the SLAVEx_CONFIG number of read operation configurations (for external sensors from x = 0 to x = 3).

Table 172. SENSORHUB18_REG register

SHub18_7	SHub18_6	SHub18_5	SHub18_4	SHub18_3	SHub18_2	SHub18_1	SHub18_0
----------	----------	----------	----------	----------	----------	----------	----------

Table 173. SENSORHUB18_REG register description

SHub18_[7:0]	Eighteenth byte associated to external sensors
--------------	--

9.71 FUNC_SRC (53h)

Significant motion, tilt, step detector, hard/soft-iron and sensor hub interrupt source register (r).

Table 174. FUNC_SRC register

STEP_COUNT_DELTA_IA	SIGN_MOTION_IA	TILT_IA	STEP_DETECTED	STEP_OVERFLOW	0 ⁽¹⁾	SI_END_OP	SENSOR_HUB_END_OP
---------------------	----------------	---------	---------------	---------------	------------------	-----------	-------------------

1. This bit must be set to '0' for the correct operation of the device.

Table 175. FUNC_SRC register description

STEP_COUNT_DELTA_IA	Pedometer step recognition on delta time status. Default value: 0 (0: no step recognized during delta time; 1: at least one step recognized during delta time)
SIGN_MOTION_IA	Significant motion event detection status. Default value: 0 (0: significant motion event not detected; 1: significant motion event detected)
TILT_IA	Tilt event detection status. Default value: 0 (0: tilt event not detected; 1: tilt event detected)
STEP_DETECTED	Step detector event detection status. Default value: 0 (0: step detector event not detected; 1: step detector event detected)
STEP_OVERFLOW	Step counter overflow status. Default value: 0 (0: step counter value < 2 ¹⁶ ; 1: step counter value reached 2 ¹⁶)
SI_END_OP	Hard/soft-iron calculation status. Default value: 0 (0: Hard/soft-iron calculation not concluded; 1: Hard/soft-iron calculation concluded)
SENSORHUB_END_OP	Sensor hub communication status. Default value: 0 (0: sensor hub communication not concluded; 1: sensor hub communication concluded)

9.72 TAP_CFG (58h)

Time stamp, pedometer, tilt, filtering, and tap recognition functions configuration register (r/w).

Table 176. TAP_CFG register

TIMER_EN	PEDO_EN	TILT_EN	SLOPE_FDS	TAP_X_EN	TAP_Y_EN	TAP_Z_EN	LIR
----------	---------	---------	-----------	----------	----------	----------	-----

Table 177. TAP_CFG register description

TIMER_EN	Time stamp count enable, output data are collected in TIMESTAMP0_REG (40h) , TIMESTAMP1_REG (41h) , TIMESTAMP2_REG (42h) register. Default: 0 (0: time stamp count disabled; 1: time stamp count enabled)
PEDO_EN	Pedometer algorithm enable. Default value: 0 (0: pedometer algorithm disabled; 1: pedometer algorithm enabled)
TILT_EN	Tilt calculation enable. Default value: 0 (0: tilt calculation disabled; 1: tilt calculation enabled.)
SLOPE_FDS	Enable accelerometer HP and LPF2 filters (refer to Figure 7). Default value: 0 (0: disable; 1: enable)
TAP_X_EN	Enable X direction in tap recognition. Default value: 0 (0: X direction disabled; 1: X direction enabled)
TAP_Y_EN	Enable Y direction in tap recognition. Default value: 0 (0: Y direction disabled; 1: Y direction enabled)
TAP_Z_EN	Enable Z direction in tap recognition. Default value: 0 (0: Z direction disabled; 1: Z direction enabled)
LIR	Latched Interrupt. Default value: 0 (0: interrupt request not latched; 1: interrupt request latched)

9.73 TAP_THS_6D (59h)

Portrait/landscape position and tap function threshold register (r/w).

Table 178. TAP_THS_6D register

D4D_EN	SIXD_THS 1	SIXD_THS 0	TAP_THS 4	TAP_THS 3	TAP_THS 2	TAP_THS 1	TAP_THS 0
--------	---------------	---------------	--------------	--------------	--------------	--------------	--------------

Table 179. TAP_THS_6D register description

D4D_EN	4D orientation detection enable. Z-axis position detection is disabled. Default value: 0 (0: enabled; 1: disabled)
SIXD_THS[1:0]	Threshold for D6D function. Default value: 00 For details, refer to Table 180 .
TAP_THS[4:0]	Threshold for tap recognition. Default value: 00000

Table 180. Threshold for D4D/D6D function

SIXD_THS[1:0]	Threshold value
00	80 degrees
01	70 degrees
10	60 degrees
11	50 degrees

9.74 INT_DUR2 (5Ah)

Tap recognition function setting register (r/w).

Table 181. INT_DUR2 register

DUR3	DUR2	DUR1	DUR0	QUIET1	QUIET0	SHOCK1	SHOCK0
------	------	------	------	--------	--------	--------	--------

Table 182. INT_DUR2 register description

DUR[3:0]	Duration of maximum time gap for double tap recognition. Default: 0000 When double tap recognition is enabled, this register expresses the maximum time between two consecutive detected taps to determine a double tap event. The default value of these bits is 0000b which corresponds to 16*ODR_XL time. If the DUR[3:0] bits are set to a different value, 1LSB corresponds to 32*ODR_XL time.
QUIET[1:0]	Expected quiet time after a tap detection. Default value: 00 Quiet time is the time after the first detected tap in which there must not be any overthreshold event. The default value of these bits is 00b which corresponds to 2*ODR_XL time. If the QUIET[1:0] bits are set to a different value, 1LSB corresponds to 4*ODR_XL time.
SHOCK[1:0]	Maximum duration of overthreshold event. Default value: 00 Maximum duration is the maximum time of an overthreshold signal detection to be recognized as a tap event. The default value of these bits is 00b which corresponds to 4*ODR_XL time. If the SHOCK[1:0] bits are set to a different value, 1LSB corresponds to 8*ODR_XL time.

9.75 WAKE_UP_THS (5Bh)

Single and double-tap function threshold register (r/w).

Table 183. WAKE_UP_THS register

SINGLE_ DOUBLE_ _TAP	INACTIVITY	WK_THS5	WK_THS4	WK_THS3	WK_THS2	WK_THS1	WK_THS0
----------------------	------------	---------	---------	---------	---------	---------	---------

Table 184. WAKE_UP_THS register description

SINGLE_DOUBLE_TAP	Single/double-tap event enable. Default: 0 (0: only single-tap event enabled; 1: both single and double-tap events enabled)
INACTIVITY	Inactivity event enable. Default value: 0 (0: sleep disabled; 1: sleep enabled)
WK_THS[5:0]	Threshold for wakeup. Default value: 000000

9.76 WAKE_UP_DUR (5Ch)

Free-fall, wakeup, time stamp and sleep mode functions duration setting register (r/w).

Table 185. WAKE_UP_DUR register

FF_DUR5	WAKE_DUR1	WAKE_DUR0	TIMER_HR	SLEEP_DUR3	SLEEP_DUR2	SLEEP_DUR1	SLEEP_DUR0
---------	-----------	-----------	----------	------------	------------	------------	------------

Table 186. WAKE_UP_DUR register description

FF_DUR5	Free fall duration event. Default: 0 For the complete configuration of the free-fall duration, refer to FF_DUR[4:0] in FREE_FALL (5Dh) configuration.
WAKE_DUR[1:0]	Wake up duration event. Default: 00 1LSB = 1 ODR_time
TIMER_HR	Time stamp register resolution setting ⁽¹⁾ . Default value: 0 (0: 1LSB = 6.4 ms; 1: 1LSB = 25 µs)
SLEEP_DUR[3:0]	Duration to go in sleep mode. Default value: 0000 1 LSB = 512 ODR

1. Configuration of this bit affects [TIMESTAMP0_REG \(40h\)](#), [TIMESTAMP1_REG \(41h\)](#), [TIMESTAMP2_REG \(42h\)](#), [STEP_TIMESTAMP_L \(49h\)](#), [STEP_TIMESTAMP_H \(4Ah\)](#), and [STEP_COUNT_DELTA \(15h\)](#) registers.

9.77 FREE_FALL (5Dh)

Free-fall function duration setting register (r/w).

Table 187. FREE_FALL register

FF_DUR4	FF_DUR3	FF_DUR2	FF_DUR1	FF_DUR0	FF_THS2	FF_THS1	FF_THS0
---------	---------	---------	---------	---------	---------	---------	---------

Table 188. FREE_FALL register description

FF_DUR[4:0]	Free-fall duration event. Default: 0 For the complete configuration of the free fall duration, refer to FF_DUR5 in WAKE_UP_DUR (5Ch) configuration
FF_THS[2:0]	Free fall threshold setting. Default: 000 For details refer to Table 189 .

Table 189. Threshold for free-fall function

FF_THS[2:0]	Threshold value
000	156 mg
001	219 mg
010	250 mg
011	312 mg
100	344 mg
101	406 mg
110	469 mg
111	500 mg

9.78 MD1_CFG (5Eh)

Functions routing on INT1 register (r/w).

Table 190. MD1_CFG register

INT1_INACT_STATE	INT1_SINGLE_TAP	INT1_WU	INT1_FF	INT1_DOUBLE_TAP	INT1_6D	INT1_TILT	INT1_TIMER

Table 191. MD1_CFG register description

INT1_INACT_STATE	Routing on INT1 of inactivity mode. Default: 0 (0: routing on INT1 of inactivity disabled; 1: routing on INT1 of inactivity enabled)
INT1_SINGLE_TAP	Single-tap recognition routing on INT1. Default: 0 (0: routing of single-tap event on INT1 disabled; 1: routing of single-tap event on INT1 enabled)
INT1_WU	Routing of wakeup event on INT1. Default value: 0 (0: routing of wakeup event on INT1 disabled; 1: routing of wakeup event on INT1 enabled)
INT1_FF	Routing of free-fall event on INT1. Default value: 0 (0: routing of free-fall event on INT1 disabled; 1: routing of free-fall event on INT1 enabled)
INT1_DOUBLE_TAP	Routing of tap event on INT1. Default value: 0 (0: routing of double-tap event on INT1 disabled; 1: routing of double-tap event on INT1 enabled)
INT1_6D	Routing of 6D event on INT1. Default value: 0 (0: routing of 6D event on INT1 disabled; 1: routing of 6D event on INT1 enabled)
INT1_TILT	Routing of tilt event on INT1. Default value: 0 (0: routing of tilt event on INT1 disabled; 1: routing of tilt event on INT1 enabled)
INT1_TIMER	Routing of end counter event of timer on INT1. Default value: 0 (0: routing of end counter event of timer on INT1 disabled; 1: routing of end counter event of timer event on INT1 enabled)

9.79 MD2_CFG (5Fh)

Functions routing on INT2 register (r/w).

Table 192. MD2_CFG register

INT2_INACT_STATE	INT2_SINGLE_TAP	INT2_WU	INT2_FF	INT2_DOUBLE_TAP	INT2_6D	INT2_TILT	INT2_IRON
------------------	-----------------	---------	---------	-----------------	---------	-----------	-----------

Table 193. MD2_CFG register description

INT2_INACT_STATE	Routing on INT2 of inactivity mode. Default: 0 (0: routing on INT2 of inactivity disabled; 1: routing on INT2 of inactivity enabled)
INT2_SINGLE_TAP	Single-tap recognition routing on INT2. Default: 0 (0: routing of single-tap event on INT2 disabled; 1: routing of single-tap event on INT2 enabled)
INT2_WU	Routing of wakeup event on INT2. Default value: 0 (0: routing of wakeup event on INT2 disabled; 1: routing of wake-up event on INT2 enabled)
INT2_FF	Routing of free-fall event on INT2. Default value: 0 (0: routing of free-fall event on INT2 disabled; 1: routing of free-fall event on INT2 enabled)
INT2_DOUBLE_TAP	Routing of tap event on INT2. Default value: 0 (0: routing of double-tap event on INT2 disabled; 1: routing of double-tap event on INT2 enabled)
INT2_6D	Routing of 6D event on INT2. Default value: 0 (0: routing of 6D event on INT2 disabled; 1: routing of 6D event on INT2 enabled)
INT2_TILT	Routing of tilt event on INT2. Default value: 0 (0: routing of tilt event on INT2 disabled; 1: routing of tilt event on INT2 enabled)
INT2_IRON	Routing of soft-iron/hard-iron algorithm end event on INT2. Default value: 0 (0: routing of soft-iron/hard-iron algorithm end event on INT2 disabled; 1: routing of soft-iron/hard-iron algorithm end event on INT2 enabled)

9.80 OUT_MAG_RAW_X_L (66h)

External magnetometer raw data (r).

Table 194. OUT_MAG_RAW_X_L register

D7	D6	D5	D4	D3	D2	D1	D0
----	----	----	----	----	----	----	----

Table 195. OUT_MAG_RAW_X_L register description

D[7:0]	X-axis external magnetometer value (LSbyte)
--------	---

9.81 OUT_MAG_RAW_X_H (67h)

External magnetometer raw data (r).

Table 196. OUT_MAG_RAW_X_H register

D15	D14	D13	D12	D11	D10	D9	D8
-----	-----	-----	-----	-----	-----	----	----

Table 197. OUT_MAG_RAW_X_H register description

D[15:8]	X-axis external magnetometer value (MSbyte)
---------	---

9.82 OUT_MAG_RAW_Y_L (68h)

External magnetometer raw data (r).

Table 198. OUT_MAG_RAW_Y_L register

D7	D6	D5	D4	D3	D2	D1	D0
----	----	----	----	----	----	----	----

Table 199. OUT_MAG_RAW_Y_L register description

D[7:0]	Y-axis external magnetometer value (LSbyte)
--------	---

9.83 OUT_MAG_RAW_Y_H (69h)

External magnetometer raw data (r).

Table 200. OUT_MAG_RAW_Y_H register

D15	D14	D13	D12	D11	D10	D9	D8
-----	-----	-----	-----	-----	-----	----	----

Table 201. OUT_MAG_RAW_Y_H register description

D[15:8]	Y-axis external magnetometer value (MSbyte)
---------	---

9.84 OUT_MAG_RAW_Z_L (6Ah)

External magnetometer raw data (r).

Table 202. OUT_MAG_RAW_Z_L register

D7	D6	D5	D4	D3	D2	D1	D0
----	----	----	----	----	----	----	----

Table 203. OUT_MAG_RAW_Z_L register description

D[7:0]	Z-axis external magnetometer value (LSbyte)
--------	---

9.85 OUT_MAG_RAW_Z_H (6Bh)

External magnetometer raw data (r).

Table 204. OUT_MAG_RAW_Z_H register

D15	D14	D13	D12	D11	D10	D9	D8
-----	-----	-----	-----	-----	-----	----	----

Table 205. OUT_MAG_RAW_Z_H register description

D[15:8]	Z-axis external magnetometer value (MSbyte)
---------	---

9.86 CTRL_SPIAux (70h)

Table 206. CTRL_SPIAux register

BLE_SPI2	0	SPI_READ_EN	0	0	0	0	3.3KHz_SPI2_EN
----------	---	-------------	---	---	---	---	----------------

Table 207. CTRL_SPIAux register description

BLE_SPI2	Big/little endian selection (same as primary interface bit)
SPI_READ_EN	Set to '1' to enable 3-wire SPI read (mandatory with current substrate but ASIC default compatible with 4-wire SPI)
3.3KHz_SPI2_EN	Enable output @ 3.3 kHz and FS = 250 dps on output data registers (22h to 27h) read by SPI2.

10 Embedded functions register mapping

The table given below provides a list of the registers for the embedded functions available in the device and the corresponding addresses. Embedded functions registers are accessible when FUNC_CFG_EN is set to '1' in *FUNC_CFG_ACCESS (01h)*.

Table 208. Registers address map - embedded functions

Name	Type	Register address		Default	Comment
		Hex	Binary		
SLV0_ADD	r/w	02	00000010	00000000	
SLV0_SUBADD	r/w	03	00000011	00000000	
SLAVE0_CONFIG	r/w	04	00000100	00000000	
SLV1_ADD	r/w	05	00000101	00000000	
SLV1_SUBADD	r/w	06	00000110	00000000	
SLAVE1_CONFIG	r/w	07	00000111	00000000	
SLV2_ADD	r/w	08	00001000	00000000	
SLV2_SUBADD	r/w	09	00001001	00000000	
SLAVE2_CONFIG	r/w	0A	00001010	00000000	
SLV3_ADD	r/w	0B	00001011	00000000	
SLV3_SUBADD	r/w	0C	00001100	00000000	
SLAVE3_CONFIG	r/w	0D	00001101	00000000	
DATAWRITE_SRC_MODE_SUB_SLV0	r/w	0E	00001110	00000000	
RESERVED	r/w	0F-12			Reserved
SM_THS	r/w	13	00010011	00000110	
RESERVED	r/w	14			Reserved
STEP_COUNT_DELTA	r/w	15	0001 0101	00000000	
MAG_SI_XX	r/w	24	00100100	00001000	
MAG_SI_XY	r/w	25	00100101	00000000	
MAG_SI_XZ	r/w	26	00100110	00000000	
MAG_SI_YX	r/w	27	00100111	00000000	
MAG_SI_YY	r/w	28	00101000	00001000	
MAG_SI_YZ	r/w	29	00101001	00000000	
MAG_SI_ZX	r/w	2A	00101010	00000000	
MAG_SI_ZY	r/w	2B	00101011	00000000	
MAG_SI_ZZ	r/w	2C	00101100	00001000	
MAG_OFFX_L	r/w	2D	00101101	00000000	

Table 208. Registers address map - embedded functions (continued)

Name	Type	Register address		Default	Comment
		Hex	Binary		
MAG_OFFX_H	r/w	2E	00101110	00000000	
MAG_OFFY_L	r/w	2F	00101111	00000000	
MAG_OFFY_H	r/w	30	00110000	00000000	
MAG_OFFZ_L	r/w	31	00110001	00000000	
MAG_OFFZ_H	r/w	32	00110010	00000000	

Registers marked as *Reserved* must not be changed. Writing to those registers may cause permanent damage to the device.

The content of the registers that are loaded at boot should not be changed. They contain the factory calibration values. Their content is automatically restored when the device is powered up.

11 Embedded functions registers description

11.1 SLV0_ADD (02h)

I²C slave address of the first external sensor (Sensor1) register (r/w).

Table 209. SLV0_ADD register

Slave0_add6	Slave0_add5	Slave0_add4	Slave0_add3	Slave0_add2	Slave0_add1	Slave0_add0	rw_0
-------------	-------------	-------------	-------------	-------------	-------------	-------------	------

Table 210. SLV0_ADD register description

Slave0_add[6:0]	I ² C slave address of Sensor1 that can be read by sensor hub. Default value: 0000000
rw_0	Read/write operation on Sensor1. Default value: 0 (0: write operation; 1: read operation)

11.2 SLV0_SUBADD (03h)

Address of register on the first external sensor (Sensor1) register (r/w).

Table 211. SLV0_SUBADD register

Slave0_reg7	Slave0_reg6	Slave0_reg5	Slave0_reg4	Slave0_reg3	Slave0_reg2	Slave0_reg1	Slave0_reg0
-------------	-------------	-------------	-------------	-------------	-------------	-------------	-------------

Table 212. SLV0_SUBADD register description

Slave0_reg[7:0]	Address of register on Sensor1 that has to be read/write according to the rw_0 bit value in <i>SLV0_ADD (02h)</i> . Default value: 00000000
-----------------	---

11.3 SLAVE0_CONFIG (04h)

First external sensor (Sensor1) configuration and sensor hub settings register (r/w).

Table 213. SLAVE0_CONFIG register

Slave0_rate1	Slave0_rate0	Aux_sens_on1	Aux_sens_on0	Src_mode	Slave0_numop2	Slave0_numop1	Slave0_numop0
--------------	--------------	--------------	--------------	----------	---------------	---------------	---------------

Table 214. SLAVE0_CONFIG register description

Slave0_rate[1:0]	Decimation of read operation on Sensor1 starting from the sensor hub trigger. Default value: 00 (00: no decimation 01: update every 2 samples 10: update every 4 samples 11: update every 8 samples)
Aux_sens_on[1:0]	Number of external sensors to be read by sensor hub. Default value: 00 (00: one sensor 01: two sensors 10: three sensors 11: four sensors)
Src_mode	Source mode conditioned read ⁽¹⁾ . Default value: 0 (0: source mode read disabled; 1: source mode read enabled)
Slave0_numop[2:0]	Number of read operations on Sensor1.

1. Read conditioned by the content of the register at address specified in *DATAWRITE_SRC_MODE_SUB_SLV0 (0Eh)* register. If the content is non-zero the operation continues with the reading of the address specified in the *SLV0_SUBADD (03h)* register, else the operation is interrupted.

11.4 SLV1_ADD (05h)

I²C slave address of the second external sensor (Sensor2) register (r/w).

Table 215. SLV1_ADD register

Slave1_add6	Slave1_add5	Slave1_add4	Slave1_add3	Slave1_add2	Slave1_add1	Slave1_add0	r_1
-------------	-------------	-------------	-------------	-------------	-------------	-------------	-----

Table 216. SLV1_ADD register description

Slave1_add[6:0]	I ² C slave address of Sensor2 that can be read by sensor hub. Default value: 0000000
r_1	Read operation on Sensor2 enable. Default value: 0 (0: read operation disabled; 1: read operation enabled)

11.5 SLV1_SUBADD (06h)

Address of register on the second external sensor (Sensor2) register (r/w).

Table 217. SLV1_SUBADD register

Slave1_reg7	Slave1_reg6	Slave1_reg5	Slave1_reg4	Slave1_reg3	Slave1_reg2	Slave1_reg1	Slave1_reg0
-------------	-------------	-------------	-------------	-------------	-------------	-------------	-------------

Table 218. SLV1_SUBADD register description

Slave1_reg[7:0]	Address of register on Sensor2 that has to be read according to the r_1 bit value in <i>SLV1_ADD (05h)</i> . Default value: 00000000
-----------------	--

11.6 SLAVE1_CONFIG (07h)

Second external sensor (Sensor2) configuration register (r/w).

Table 219. SLAVE1_CONFIG register

Slave1_rate1	Slave1_rate0	0 ⁽¹⁾	0 ⁽¹⁾	0 ⁽¹⁾	Slave1_numop2	Slave1_numop1	Slave1_numop0
--------------	--------------	------------------	------------------	------------------	---------------	---------------	---------------

1. This bit must be set to '0' for the correct operation of the device.

Table 220. SLAVE1_CONFIG register description

Slave1_rate[1:0]	Decimation of read operation on Sensor2 starting from the sensor hub trigger. Default value: 00 (00: no decimation 01: update every 2 samples 10: update every 4 samples 11: update every 8 samples)
Slave1_numop[2:0]	Number of read operations on Sensor2.

11.7 SLV2_ADD (08h)

I²C slave address of the third external sensor (Sensor3) register (r/w).

Table 221. SLV2_ADD register

Slave2_add6	Slave2_add5	Slave2_add4	Slave2_add3	Slave2_add2	Slave2_add1	Slave2_add0	r_2
-------------	-------------	-------------	-------------	-------------	-------------	-------------	-----

Table 222. SLV2_ADD register description

Slave2_add[6:0]	I ² C slave address of Sensor3 that can be read by sensor hub. Default value: 0000000
r_2	Read operation on Sensor3 enable. Default value: 0 (0: read operation disabled; 1: read operation enabled)

11.8 SLV2_SUBADD (09h)

Address of register on the third external sensor (Sensor3) register (r/w).

Table 223. SLV2_SUBADD register

Slave2_reg7	Slave2_reg6	Slave2_reg5	Slave2_reg4	Slave2_reg3	Slave2_reg2	Slave2_reg1	Slave2_reg0
-------------	-------------	-------------	-------------	-------------	-------------	-------------	-------------

Table 224. SLV2_SUBADD register description

Slave2_reg[7:0]	Address of register on Sensor3 that has to be read according to the r_2 bit value in SLV2_ADD (08h) . Default value: 00000000
-----------------	---

11.9 SLAVE2_CONFIG (0Ah)

Third external sensor (Sensor3) configuration register (r/w).

Table 225. SLAVE2_CONFIG register

Slave2_rate1	Slave2_rate0	0 ⁽¹⁾	0 ⁽¹⁾	0 ⁽¹⁾	Slave2_numop2	Slave2_numop1	Slave2_numop0
--------------	--------------	------------------	------------------	------------------	---------------	---------------	---------------

1. This bit must be set to '0' for the correct operation of the device.

Table 226. SLAVE2_CONFIG register description

Slave2_rate[1:0]	Decimation of read operation on Sensor3 starting from the sensor hub trigger. Default value: 00 (00: no decimation 01: update every 2 samples 10: update every 4 samples 11: update every 8 samples)
Slave2_numop[2:0]	Number of read operations on Sensor3.

11.10 SLV3_ADD (0Bh)

I²C slave address of the fourth external sensor (Sensor4) register (r/w).

Table 227. SLV3_ADD register

Slave3_add6	Slave3_add5	Slave3_add4	Slave3_add3	Slave3_add2	Slave3_add1	Slave3_add0	r_3
-------------	-------------	-------------	-------------	-------------	-------------	-------------	-----

Table 228. SLV3_ADD register description

Slave3_add[6:0]	I ² C slave address of Sensor4 that can be read by the sensor hub. Default value: 0000000
r_3	Read operation on Sensor4 enable. Default value: 0 (0: read operation disabled; 1: read operation enabled)

11.11 SLV3_SUBADD (0Ch)

Address of register on the fourth external sensor (Sensor4) register (r/w).

Table 229. SLV3_SUBADD register

Slave3_reg7	Slave3_reg6	Slave3_reg5	Slave3_reg4	Slave3_reg3	Slave3_reg2	Slave3_reg1	Slave3_reg0
-------------	-------------	-------------	-------------	-------------	-------------	-------------	-------------

Table 230. SLV3_SUBADD register description

Slave3_reg[7:0]	Address of register on Sensor4 that has to be read according to the r_3 bit value in <i>SLV3_ADD (0Bh)</i> . Default value: 00000000
-----------------	--

11.12 SLAVE3_CONFIG (0Dh)

Fourth external sensor (Sensor4) configuration register (r/w).

Table 231. SLAVE3_CONFIG register

Slave3_rate1	Slave3_rate0	0 ⁽¹⁾	0 ⁽¹⁾	0 ⁽¹⁾	Slave3_numop2	Slave3_numop1	Slave3_numop0
--------------	--------------	------------------	------------------	------------------	---------------	---------------	---------------

1. This bit must be set to '0' for the correct operation of the device.

Table 232. SLAVE3_CONFIG register description

Slave3_rate[1:0]	Decimation of read operation on Sensor4 starting from the sensor hub trigger. Default value: 00 (00: no decimation 01: update every 2 samples 10: update every 4 samples 11: update every 8 samples)
Slave3_numop[2:0]	Number of read operations on Sensor4.

11.13 DATAWRITE_SRC_MODE_SUB_SLV0 (0Eh)

Data to be written into the slave device register (r/w).

Table 233. DATAWRITE_SRC_MODE_SUB_SLV0 register

Slave_dataw7	Slave_dataw6	Slave_dataw5	Slave_dataw4	Slave_dataw3	Slave_dataw2	Slave_dataw1	Slave_dataw0
--------------	--------------	--------------	--------------	--------------	--------------	--------------	--------------

Table 234. DATAWRITE_SRC_MODE_SUB_SLV0 register description

Slave_dataw[7:0]	Data to be written into the slave device according to the rw_0 bit in SLV0_ADD (02h) register or address to be read in source mode. Default value: 00000000
------------------	--

11.14 SM_THS (13h)

Significant motion configuration register (r/w).

Table 235. SM_THS register

SM_THS_7	SM_THS_6	SM_THS_5	SM_THS_4	SM_THS_3	SM_THS_2	SM_THS_1	SM_THS_0
----------	----------	----------	----------	----------	----------	----------	----------

Table 236. SM_THS register description

SM_THS[7:0]	Significant motion threshold. Default value: 00000110
-------------	---

11.15 STEP_COUNT_DELTA (15h)

Time period register for step detection on delta time (r/w).

Table 237. STEP_COUNT_DELTA register

SC_ DELTA_7	SC_ DELTA_6	SC_ DELTA_5	SC_ DELTA_4	SC_ DELTA_3	SC_ DELTA_2	SC_ DELTA_1	SC_ DELTA_0
----------------	----------------	----------------	----------------	----------------	----------------	----------------	----------------

Table 238. STEP_COUNT_DELTA register description

SC_DELTA[7:0]	Time period value ⁽¹⁾ (1LSB = 1.6384 s)
---------------	--

1. This value is effective if the TIMER_EN bit of the TAP_CFG register is set to 1 and the TIMER_HR bit of the WAKE_UP_DUR register is set to 0.

11.16 MAG_SI_XX (24h)

Soft-iron matrix correction register (r/w).

Table 239. MAG_SI_XX register

MAG_SI_ XX_7	MAG_SI_ XX_6	MAG_SI_ XX_5	MAG_SI_ XX_4	MAG_SI_ XX_3	MAG_SI_ XX_2	MAG_SI_ XX_1	MAG_SI_ XX_0
-----------------	-----------------	-----------------	-----------------	-----------------	-----------------	-----------------	-----------------

Table 240. MAG_SI_XX register description

MAG_SI_XX_[7:0]	Soft-iron correction row1 col1 coefficient ⁽¹⁾ . Default value: 00001000
-----------------	---

1. Value is expressed in sign-module format.

11.17 MAG_SI_XY (25h)

Soft-iron matrix correction register (r/w).

Table 241. MAG_SI_XY register

MAG_SI_ XY_7	MAG_SI_ XY_6	MAG_SI_ XY_5	MAG_SI_ XY_4	MAG_SI_ XY_3	MAG_SI_ XY_2	MAG_SI_ XY_1	MAG_SI_ XY_0
-----------------	-----------------	-----------------	-----------------	-----------------	-----------------	-----------------	-----------------

Table 242. MAG_SI_XY register description

MAG_SI_XY_[7:0]	Soft-iron correction row1 col2 coefficient ⁽¹⁾ . Default value: 00000000
-----------------	---

1. Value is expressed in sign-module format.

11.18 MAG_SI_XZ (26h)

Soft-iron matrix correction register (r/w).

Table 243. MAG_SI_XZ register

MAG_SI_ XZ_7	MAG_SI_ XZ_6	MAG_SI_ XZ_5	MAG_SI_ XZ_4	MAG_SI_ XZ_3	MAG_SI_ XZ_2	MAG_SI_ XZ_1	MAG_SI_ XZ_0
-----------------	-----------------	-----------------	-----------------	-----------------	-----------------	-----------------	-----------------

Table 244. MAG_SI_XZ register description

MAG_SI_XZ_[7:0]	Soft-iron correction row1 col3 coefficient ⁽¹⁾ . Default value: 00000000
-----------------	---

1. Value is expressed in sign-module format.

11.19 MAG_SI_YX (27h)

Soft-iron matrix correction register (r/w).

Table 245. MAG_SI_YX register

MAG_SI_YX_7	MAG_SI_YX_6	MAG_SI_YX_5	MAG_SI_YX_4	MAG_SI_YX_3	MAG_SI_YX_2	MAG_SI_YX_1	MAG_SI_YX_0
-------------	-------------	-------------	-------------	-------------	-------------	-------------	-------------

Table 246. MAG_SI_YX register description

MAG_SI_YX_[7:0]	Soft-iron correction row2 col1 coefficient ⁽¹⁾ . Default value: 00000000
-----------------	---

1. Value is expressed in sign-module format.

11.20 MAG_SI_YY (28h)

Soft-iron matrix correction register (r/w).

Table 247. MAG_SI_YY register

MAG_SI_YY_7	MAG_SI_YY_6	MAG_SI_YY_5	MAG_SI_YY_4	MAG_SI_YY_3	MAG_SI_YY_2	MAG_SI_YY_1	MAG_SI_YY_0
-------------	-------------	-------------	-------------	-------------	-------------	-------------	-------------

Table 248. MAG_SI_YY register description

MAG_SI_YY_[7:0]	Soft-iron correction row2 col2 coefficient ⁽¹⁾ . Default value: 00001000
-----------------	---

1. Value is expressed in sign-module format.

11.21 MAG_SI_YZ (29h)

Soft-iron matrix correction register (r/w).

Table 249. MAG_SI_YZ register

MAG_SI_YZ_7	MAG_SI_YZ_6	MAG_SI_YZ_5	MAG_SI_YZ_4	MAG_SI_YZ_3	MAG_SI_YZ_2	MAG_SI_YZ_1	MAG_SI_YZ_0
-------------	-------------	-------------	-------------	-------------	-------------	-------------	-------------

Table 250. MAG_SI_YZ register description

MAG_SI_YZ_[7:0]	Soft-iron correction row2 col3 coefficient ⁽¹⁾ . Default value: 00000000
-----------------	---

1. Value is expressed in sign-module format.

11.22 MAG_SI_ZX (2Ah)

Soft-iron matrix correction register (r/w).

Table 251. MAG_SI_ZX register

MAG_SI_ZX_7	MAG_SI_ZX_6	MAG_SI_ZX_5	MAG_SI_ZX_4	MAG_SI_ZX_3	MAG_SI_ZX_2	MAG_SI_ZX_1	MAG_SI_ZX_0
-------------	-------------	-------------	-------------	-------------	-------------	-------------	-------------

Table 252. MAG_SI_ZX register description

MAG_SI_ZX_[7:0]	Soft-iron correction row3 col1 coefficient ⁽¹⁾ . Default value: 00000000
-----------------	---

1. Value is expressed in sign-module format.

11.23 MAG_SI_ZY (2Bh)

Soft-iron matrix correction register (r/w).

Table 253. MAG_SI_ZY register

MAG_SI_ZY_7	MAG_SI_ZY_6	MAG_SI_ZY_5	MAG_SI_ZY_4	MAG_SI_ZY_3	MAG_SI_ZY_2	MAG_SI_ZY_1	MAG_SI_ZY_0
-------------	-------------	-------------	-------------	-------------	-------------	-------------	-------------

Table 254. MAG_SI_ZY register description

MAG_SI_ZY_[7:0]	Soft-iron correction row3 col2 coefficient ⁽¹⁾ . Default value: 00000000
-----------------	---

1. Value is expressed in sign-module format.

11.24 MAG_SI_ZZ (2Ch)

Soft-iron matrix correction register (r/w).

Table 255. MAG_SI_ZZ register

MAG_SI_ZZ_7	MAG_SI_ZZ_6	MAG_SI_ZZ_5	MAG_SI_ZZ_4	MAG_SI_ZZ_3	MAG_SI_ZZ_2	MAG_SI_ZZ_1	MAG_SI_ZZ_0
-------------	-------------	-------------	-------------	-------------	-------------	-------------	-------------

Table 256. MAG_SI_ZZ register description

MAG_SI_ZZ_[7:0]	Soft-iron correction row3 col3 coefficient ⁽¹⁾ . Default value: 00001000
-----------------	---

1. Value is expressed in sign-module format.

11.25 MAG_OFFX_L (2Dh)

Offset for X-axis hard-iron compensation register (r/w). The value is expressed as a 16-bit word in two's complement.

Table 257. MAG_OFFX_L register

MAG_OFFX_L_7	MAG_OFFX_L_6	MAG_OFFX_L_5	MAG_OFFX_L_4	MAG_OFFX_L_3	MAG_OFFX_L_2	MAG_OFFX_L_1	MAG_OFFX_L_0
--------------	--------------	--------------	--------------	--------------	--------------	--------------	--------------

Table 258. MAG_OFFX_L register description

MAG_OFFX_L_[7:0]	Offset for X-axis hard-iron compensation. Default value: 00000000
------------------	---

11.26 MAG_OFFX_H (2Eh)

Offset for X-axis hard-iron compensation register (r/w). The value is expressed as a 16-bit word in two's complement.

Table 259. MAG_OFFX_H register

MAG_OFFX_H_7	MAG_OFFX_H_6	MAG_OFFX_H_5	MAG_OFFX_H_4	MAG_OFFX_H_3	MAG_OFFX_H_2	MAG_OFFX_H_1	MAG_OFFX_H_0
--------------	--------------	--------------	--------------	--------------	--------------	--------------	--------------

Table 260. MAG_OFFX_H register description

MAG_OFFX_H_[7:0]	Offset for X-axis hard-iron compensation. Default value: 00000000
------------------	---

11.27 MAG_OFFY_L (2Fh)

Offset for Y-axis hard-iron compensation register (r/w). The value is expressed as a 16-bit word in two's complement.

Table 261. MAG_OFFY_L register

MAG_OFF Y_L_7	MAG_OFF Y_L_6	MAG_OFF Y_L_5	MAG_OFF Y_L_4	MAG_OFF Y_L_3	MAG_OFF Y_L_2	MAG_OFF Y_L_1	MAG_OFF Y_L_0
------------------	------------------	------------------	------------------	------------------	------------------	------------------	------------------

Table 262. MAG_OFFY_L register description

MAG_OFFY_L[7:0]	Offset for Y-axis hard-iron compensation. Default value: 00000000
-----------------	---

11.28 MAG_OFFY_H (30h)

Offset for Y-axis hard-iron compensation register (r/w). The value is expressed as a 16-bit word in two's complement.

Table 263. MAG_OFFY_H register

MAG_OFF Y_H_7	MAG_OFF Y_H_6	MAG_OFF Y_H_5	MAG_OFF Y_H_4	MAG_OFF Y_H_3	MAG_OFF Y_H_2	MAG_OFF Y_H_1	MAG_OFF Y_H_0
------------------	------------------	------------------	------------------	------------------	------------------	------------------	------------------

Table 264. MAG_OFFY_H register description

MAG_OFFY_H[7:0]	Offset for Y-axis hard-iron compensation. Default value: 00000000
-----------------	---

11.29 MAG_OFFZ_L (31h)

Offset for Z-axis hard-iron compensation register (r/w). The value is expressed as a 16-bit word in two's complement.

Table 265. MAG_OFFZ_L register

MAG_OFF Z_L_7	MAG_OFF Z_L_6	MAG_OFF Z_L_5	MAG_OFF Z_L_4	MAG_OFF Z_L_3	MAG_OFF Z_L_2	MAG_OFF Z_L_1	MAG_OFF Z_L_0
------------------	------------------	------------------	------------------	------------------	------------------	------------------	------------------

Table 266. MAG_OFFZ_L register description

MAG_OFFZ_L[7:0]	Offset for Z-axis hard-iron compensation. Default value: 00000000
-----------------	---

11.30 MAG_OFFZ_H (32h)

Offset for Z-axis hard-iron compensation register (r/w). The value is expressed as a 16-bit word in two's complement.

Table 267. MAG_OFFZ_H register

MAG_OFF Z_H_7	MAG_OFF Z_H_6	MAG_OFF Z_H_5	MAG_OFF Z_H_4	MAG_OFF Z_H_3	MAG_OFF Z_H_2	MAG_OFF Z_H_1	MAG_OFF Z_H_0
------------------	------------------	------------------	------------------	------------------	------------------	------------------	------------------

Table 268. MAG_OFFZ_H register description

MAG_OFFZ_H[7:0]	Offset for Z-axis hard-iron compensation. Default value: 00000000
-----------------	---

12 Soldering information

The LGA package is compliant with the ECOPACK®, RoHS and "Green" standard. It is qualified for soldering heat resistance according to JEDEC J-STD-020.

Leave "Pin 1 Indicator" unconnected during soldering.

Land pattern and soldering recommendations are available at www.st.com/mems.

13 Package information

In order to meet environmental requirements, ST offers these devices in different grades of ECOPACK® packages, depending on their level of environmental compliance. ECOPACK® specifications, grade definitions and product status are available at: www.st.com. ECOPACK is an ST trademark.

13.1 LGA-14 package information

Figure 18. LGA-14 2.5x3x0.86 14L package outline and mechanical data

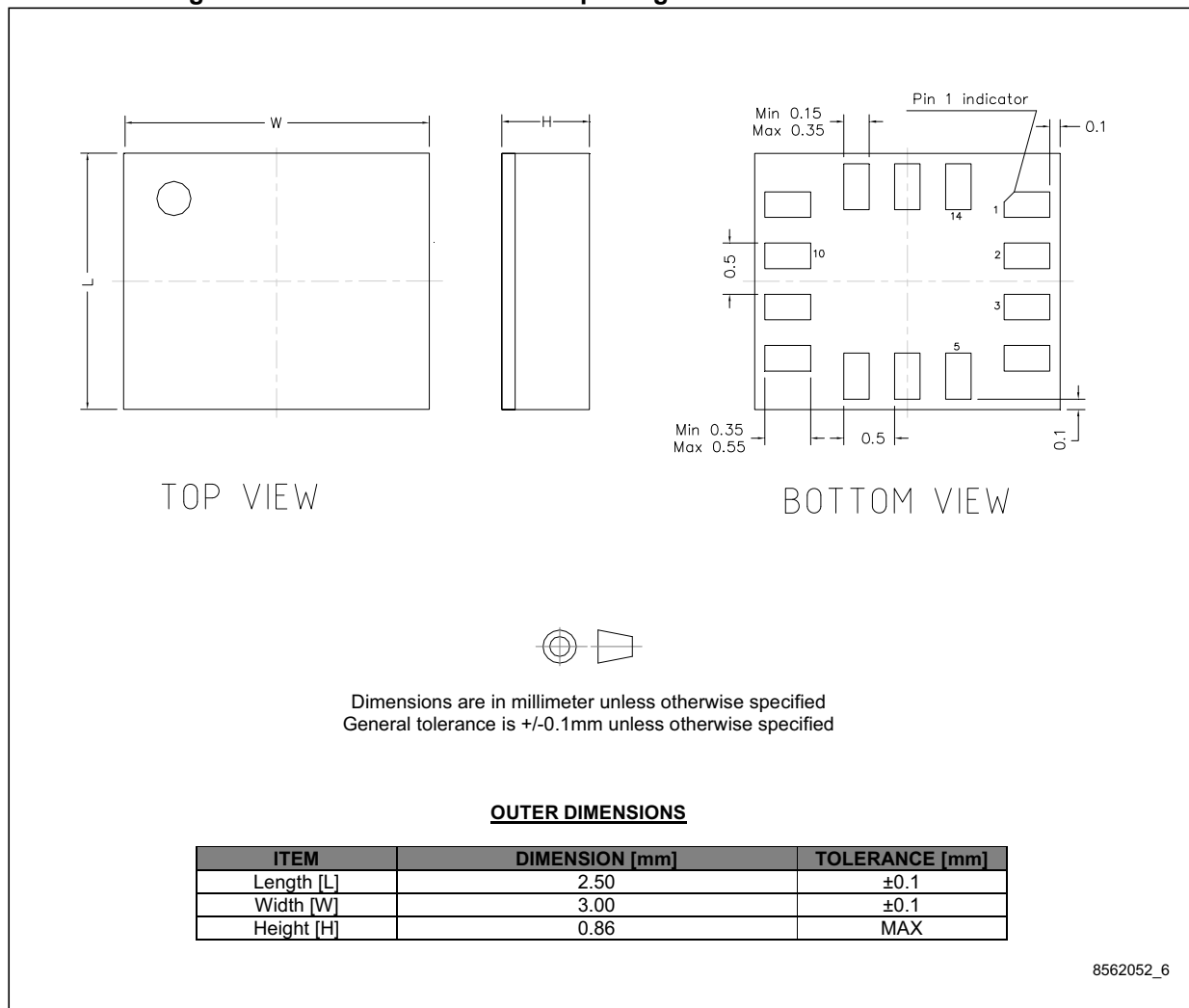

8562052_6

14 Revision history

Table 269. Document revision history

Date	Revision	Changes
14-Sep-2015	1	Initial release
15-Sep-2015	2	Updated <i>Features</i>

IMPORTANT NOTICE – PLEASE READ CAREFULLY

STMicroelectronics NV and its subsidiaries (“ST”) reserve the right to make changes, corrections, enhancements, modifications, and improvements to ST products and/or to this document at any time without notice. Purchasers should obtain the latest relevant information on ST products before placing orders. ST products are sold pursuant to ST’s terms and conditions of sale in place at the time of order acknowledgement.

Purchasers are solely responsible for the choice, selection, and use of ST products and ST assumes no liability for application assistance or the design of Purchasers’ products.

No license, express or implied, to any intellectual property right is granted by ST herein.

Resale of ST products with provisions different from the information set forth herein shall void any warranty granted by ST for such product.

ST and the ST logo are trademarks of ST. All other product or service names are the property of their respective owners.

Information in this document supersedes and replaces information previously supplied in any prior versions of this document.

© 2015 STMicroelectronics – All rights reserved