

LT023PS

Features

- Compact (diameter: 5.6mm)
- Low noise S/N: -80 dB (according to measurement method Fig 27-2)
- Wavelength: 780nm
- Single transverse mode
- Multi longitudinal mode

Applications

- Video disc players
- Fiber optic communications
- Light source for analog processing
- Measurement instruments
- Analysis instruments

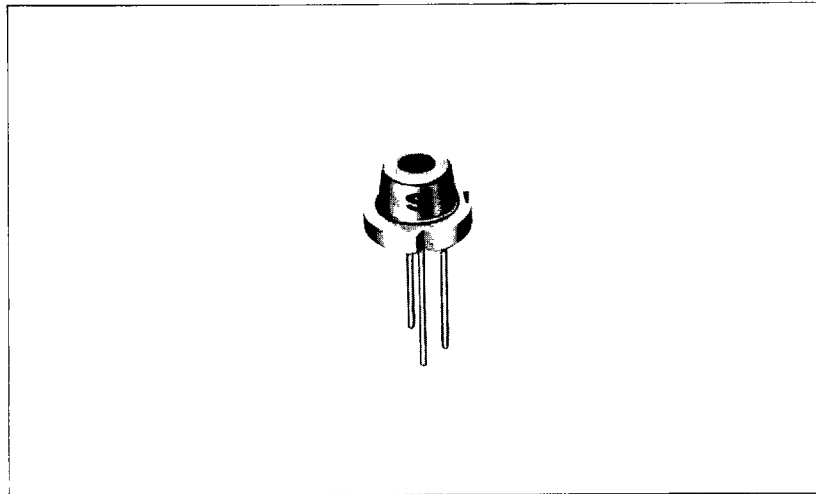

Absolute Maximum Ratings

(T_c = 25°C)

Parameter	Symbol	Ratings	Units
Optical power output	P _o	5	mW
Reverse voltage	Laser	2	V
	PIN	30	
Operating temperature* ¹	T _{opr}	-10 to +70	°C
Storage temperature* ¹	T _{stg}	-40 to +85	°C

*1 Case temperature

Electro-optical Characteristics*¹

(T_c = 25°C)

Parameter	Symbol	Condition	Ratings			Units	
			MIN	TYP	MAX		
Threshold current	I _{th}	---	---	45	60	mA	
Operating current	I _{op}	P _o = 3mW	---	55	75	mA	
Operating voltage	V _{op}	P _o = 3mW	---	1.75	2.0	V	
Wavelength* ²	λ _p	P _o = 3mW	770	780	795	nm	
Monitor current	I _m	P _o = 3mW V _R = 15V	0.08	0.20	0.42	mA	
Radiation characteristics	Angle* ³	Parallel to junction	θ _∥	8.5	11	16	deg
		Perpendicular to junction	θ _⊥	29	38	48	deg
	Ripple	P _o = 3mW	---	---	±20	%	
Emission point accuracy	Angle	Δφ _∥	P _o = 3mW	---	---	±2	deg
		Δφ _⊥	P _o = 3mW	---	---	±3	deg
	Position	Δx, Δy, Δz	---	---	---	±80	μm
Differential efficiency	η	$\frac{2\text{mW}}{I_F(3\text{mW}) - I_F(1\text{mW})}$	0.1	0.3	0.5	mW/mA	
Coherence	γ	P _o = 3mW	---	---	0.47		

*1 Initial value

*3 Angle at 50% peak intensity (full width at half-maximum)

*2 Single transverse mode

Electrical Characteristics of Photodiode

(T_c = 25°C)

Parameter	Symbol	Condition	Ratings			Units
			MIN	TYP	MAX	
Sensitivity	S	V _R = 15V	---	0.07	---	mA/mW
Dark current	I _D	V _R = 15V	---	---	150	nA
Terminal capacitance	C _t	V _R = 15V	---	9	---	pF

Common Data

Fig. 94-1 Optical Power Output Dependence of Far-Field Pattern

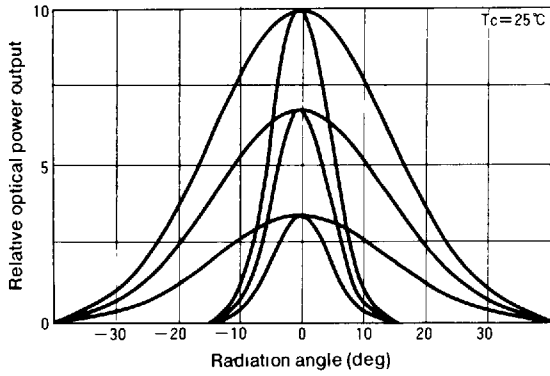

Fig. 94-4 Coupling Efficiency

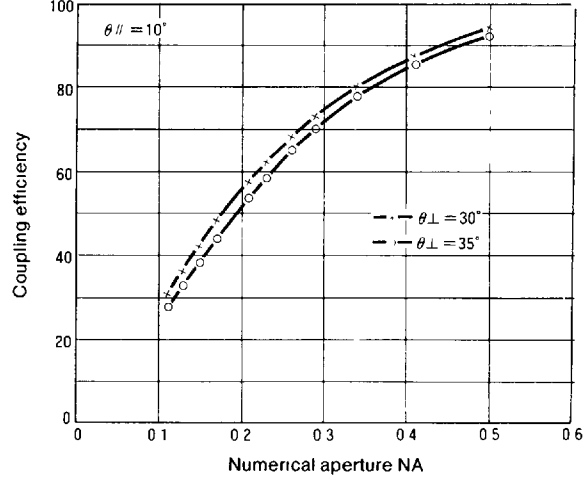

Fig. 94-2 Polarization Ratio vs. Optical Power Output (LT026 series, LT023 series)

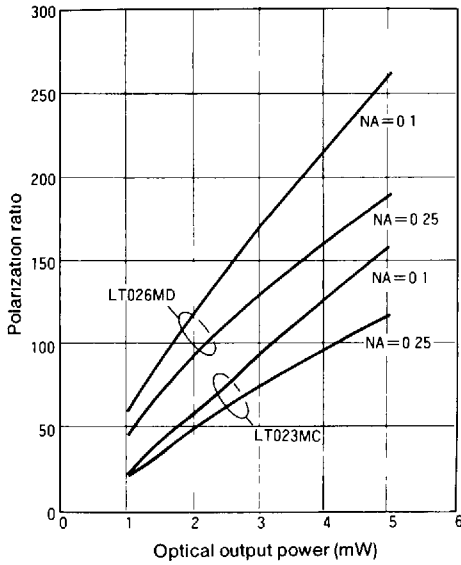

Fig. 94-5 Frequency Response

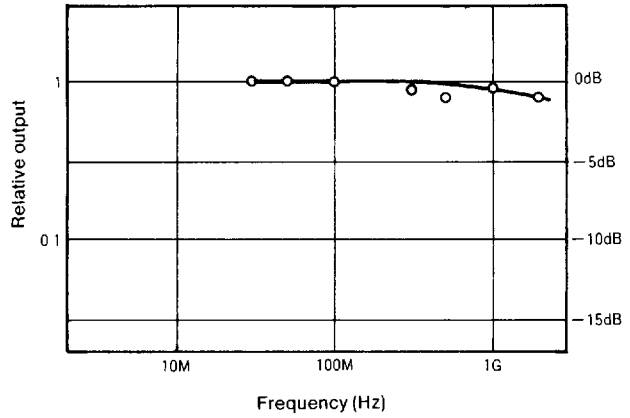
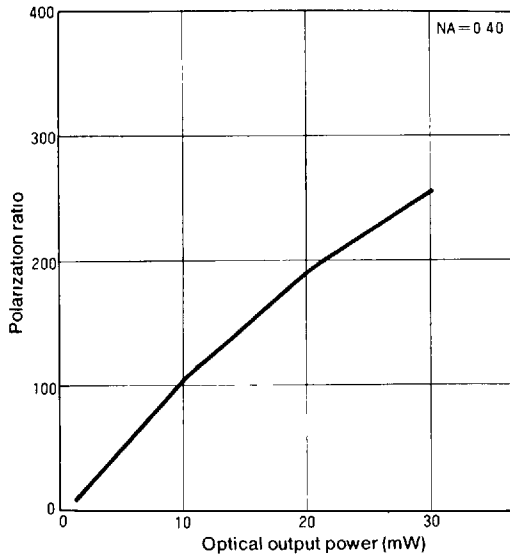

Fig. 94-3 Polarization Ratio vs. Optical Power Output (LT024 series, LT015 series)



Note All data on this page is typical only, and is not intended as a specification. The shapes of these curves can be used as a general reference, but the actual characteristics will vary from device to device.

Built-in PIN Photodiode Characteristics

Fig. 95-1 Photodiode Frequency Response Characteristic

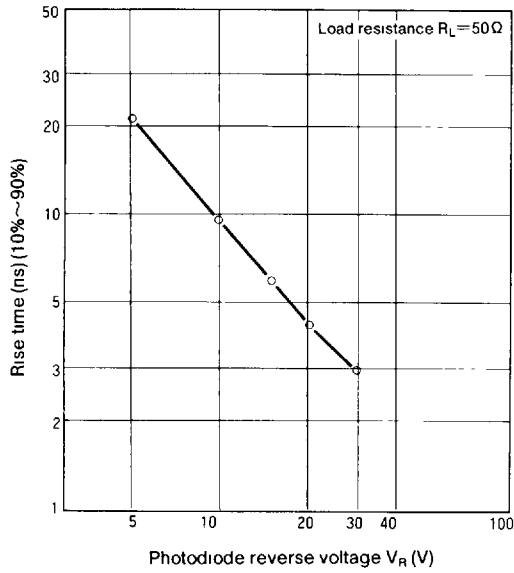
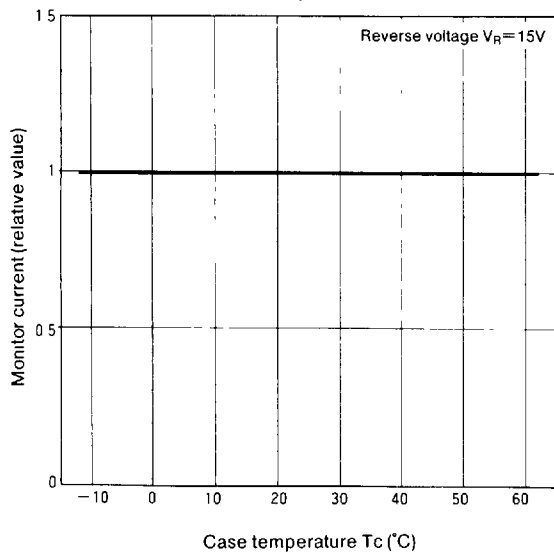

Fig. 95-2 Photodiode Temperature Characteristic



Note: All data on this page is typical only, and is not intended as a specification. The shapes of these curves can be used as a general reference, but the actual characteristics will vary from device to device.

Outline Dimensions

Unit: mm

Fig. 98-1 Standard Type (C Type)

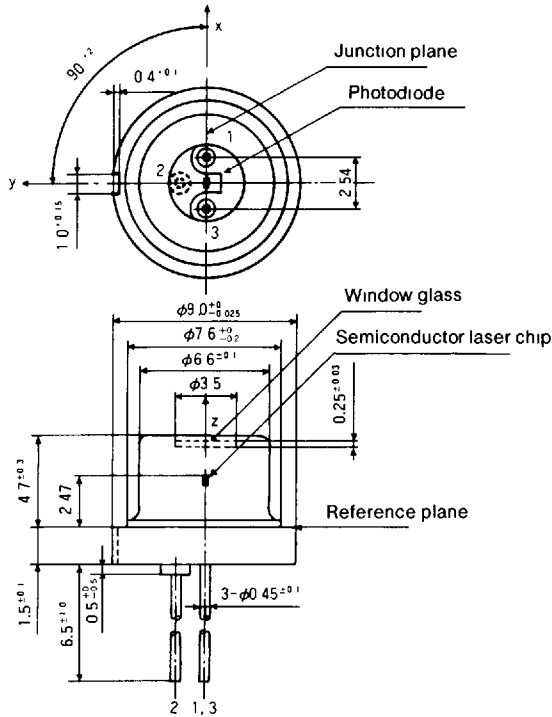

Fig. 98-2 Low-Cap Type (D Type)

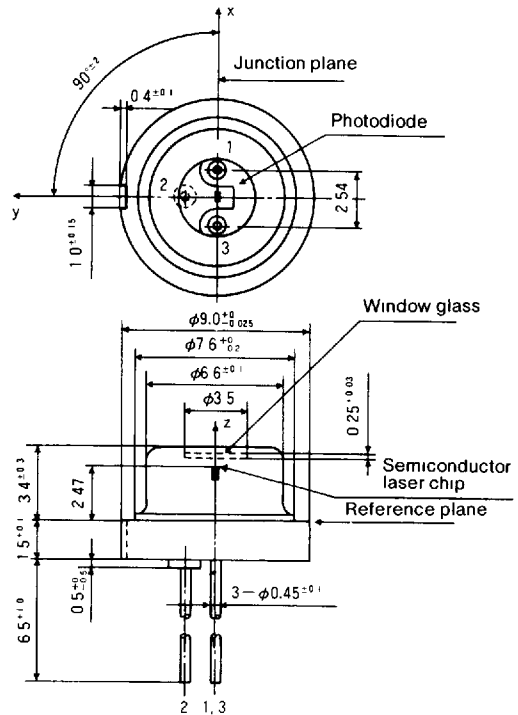

Fig. 98-3 Fin-Equipped Type (F Type)

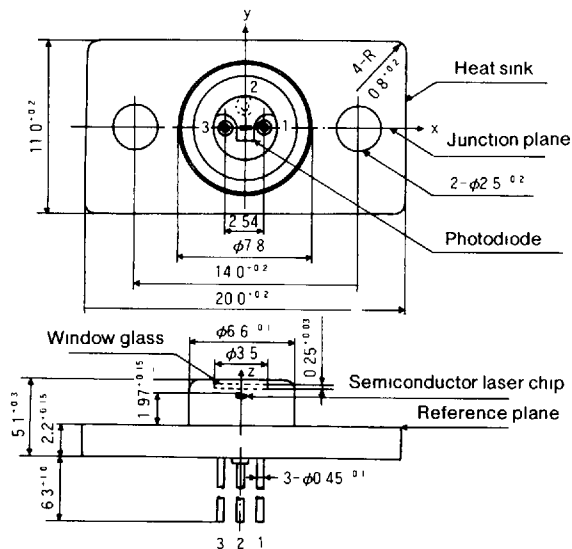
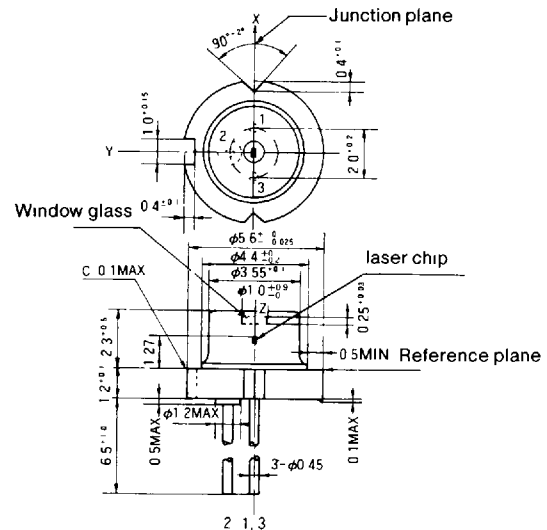

Fig. 98-4 Compact Package Type (S Type)



Terminal connections

