

FEATURES

- Greatly Reduced Conducted and Radiated EMI ($100\mu\text{V}_{\text{P-P}}$ in Typical Application)
- Low Switching Harmonic Content
- Independent Control of Switch Voltage and Current Slew Rates
- Two 1A Current Limited Power Switches
- Regulates Positive and Negative Voltages
- 20kHz to 250kHz Oscillator Frequency
- Easily Synchronized to External Clock
- Wide Input Voltage Range: 2.7V to 23V
- Low Shutdown Current: 12 μA Typical
- Easier Layout than with Conventional Switchers
- Outputs Can Be Forced to 50% Duty Cycle for Unregulated Applications

APPLICATIONS

- Precision Instrumentation Systems
- Isolated Supplies for Industrial Automation
- Medical Instruments
- Wireless Communications
- Single Board Data Acquisition Systems

LT, LTC and LT are registered trademarks of Linear Technology Corporation.

DESCRIPTION

The LT[®]1533 is a new class of switching regulator designed to reduce conducted and radiated electromagnetic interference (EMI). Ultralow noise and EMI are achieved by providing user control of the output switch slew rates. Voltage and current slew rates can be independently programmed to optimize switcher harmonic content versus efficiency. The LT1533 can reduce high frequency harmonic power by as much as 40dB with only minor losses in efficiency.

The LT1533 utilizes a dual output switch current mode architecture optimized for low noise topologies. The IC includes two 1A power switches along with all necessary oscillator, control and protection circuitry. Unique error amp circuitry can regulate both positive and negative voltages. The internal oscillator may be synchronized to an external clock for more accurate placement of switching harmonics. Protection features include cycle by cycle current limit protection, undervoltage lockout and thermal shutdown.

Low minimum supply voltage and low supply current during shutdown make the LT1533 well suited for portable applications. The part may also be forced into a 50% duty cycle mode for unregulated applications. The LT1533 is available in the 16-pin narrow SO package.

TYPICAL APPLICATION

Low Noise 5V to 12V Forward Push-Pull DC/DC Converter

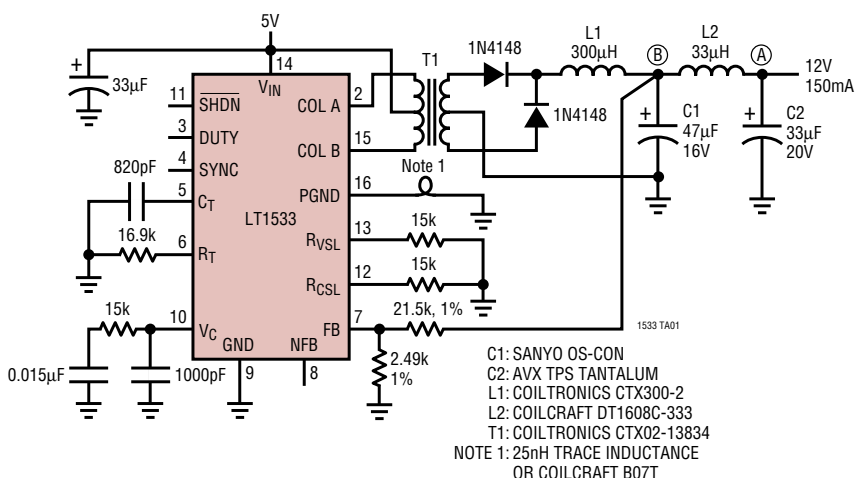

12V Output Noise (BW = 100MHz)

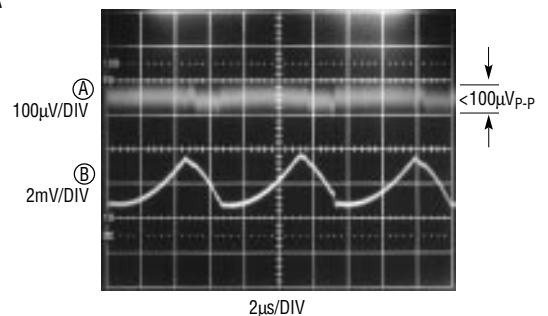

ABSOLUTE MAXIMUM RATINGS

(Note 1)

Input Voltage (V_{IN})	30V
Switch Voltage (COL A, COL B)	30V
SHDN Pin Voltage	30V
Feedback Pin Current	10mA
Negative Feedback Pin Current	± 10 mA
Storage Temperature Range	-65°C to 150°C
Maximum Junction Temperature	125°C
Operating Junction Temperature Range	
LT1533C	0°C to 100°C
LT1533I	-40°C to 100°C
Lead Temperature (Soldering, 10 sec).....	300°C

PACKAGE/ORDER INFORMATION

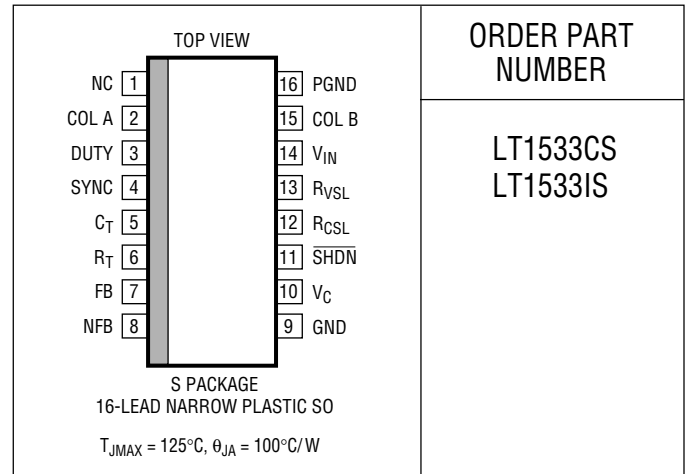

ORDER PART NUMBER

LT1533CS
LT1533IS

Consult factory for Military grade parts.

ELECTRICAL CHARACTERISTICS

$V_{IN} = 5\text{V}$, $V_C = 0.9\text{V}$, $V_{FB} = V_{REF}$. COL A, COL B, SHDN, NFB, DUTY pins open, unless otherwise noted.

SYMBOL	PARAMETER	CONDITIONS	MIN	TYP	MAX	UNITS	
Supply and Protection							
V_{IN}	Recommended Operating Range		● 2.7		23	V	
$V_{IN(MIN)}$	Minimum Input Voltage		●	2.55	2.7	V	
I_{VIN}	Supply Current	$2.7\text{V} \leq V_{IN} \leq 23\text{V}$, R_{VSL} , R_{CSL} , $R_T = 17\text{k}$	●	12	18	mA	
$I_{VIN(OFF)}$	Shutdown Supply Current	$2.7\text{V} \leq V_{IN} \leq 23\text{V}$, $V_{SHDN} = 0\text{V}$	●	12	30	μA	
V_{SHDN}	Shutdown Threshold	$2.7\text{V} \leq V_{IN} \leq 23\text{V}$	●	0.4	0.8	V	
I_{SHDN}	Shutdown Input Current			-2		μA	
Error Amplifiers							
V_{REF}	Reference Voltage	Measured at Feedback Pin	●	1.235 1.215	1.250 1.275	V V	
I_{FB}	Feedback Input Current	$V_{FB} = V_{REF}$	●	250	900	nA	
FB_{REG}	Reference Voltage Line Regulation	$2.7\text{V} \leq V_{IN} \leq 23\text{V}$	●	0.003	0.03	%/V	
V_{NFR}	Negative Feedback Reference Voltage	Measured at Negative Feedback Pin with Feedback Pin Open	●	-2.550	-2.500	-2.420	V
I_{NFR}	Negative Feedback Input Current	$V_{NFB} = V_{NFR}$	●	-37	-25	μA	
NFB_{REG}	Negative Feedback Reference Voltage Line Regulation	$2.7\text{V} \leq V_{IN} \leq 23\text{V}$	●	0.002	0.05	%/V	

ELECTRICAL CHARACTERISTICS

$V_{IN} = 5V$, $V_C = 0.9V$, $V_{FB} = V_{REF}$. COL A, COL B, \overline{SHDN} , NFB, DUTY pins open, unless otherwise noted.

SYMBOL	PARAMETER	CONDITIONS	MIN	TYP	MAX	UNITS
g_m	Error Amplifier Transconductance	$\Delta I_C = \pm 25\mu A$	1100 700	1500	1900 2300	μmho μmho
I_{ESK}	Error Amplifier Sink Current	$V_{FB} = V_{REF} + 150mV$, $V_C = 0.9V$, $V_{\overline{SHDN}} = 1V$	120	200	350	μA
I_{ESRC}	Error Amplifier Source Current	$V_{FB} = V_{REF} - 150mV$, $V_C = 0.9V$, $V_{\overline{SHDN}} = 1V$	120	200	350	μA
V_{CLH}	Error Amplifier Clamp Voltage	High Clamp, $V_{FB} = 1V$		1.33		V
V_{CLL}	Error Amplifier Clamp Voltage	Low Clamp, $V_{FB} = 1.5V$		0.1		V
A_V	Error Amplifier Voltage Gain		180	250		V/V

Oscillator and Sync

f_{MAX}	Maximum Switch Frequency			250		kHz
f_{SYNC}	Synchronization Frequency Range	$f_{OSC} = 250kHz$			375	kHz
R_{SYNC}	SYNC Pin Input Resistance			40		k Ω
V_{FBfs}	FB Pin Threshold for Frequency Shift	5% Reduction from Nominal		0.4		V

Output Switches

DC_{MAX}	Maximum Switch Duty Cycle	DUTY Pin Open, $R_{VSL} = R_{CSL} = 4.9k$, $f_{OSC} = 25kHz$ DUTY Pin Grounded, Forced 50% Duty Cycle	●	44	45.5 50.0	% %
t_{IBL}	Switch Current Limit Blanking Time			200		ns
BV	Output Switch Breakdown Voltage	$2.7V \leq V_{IN} \leq 23V$	●	25	30	V
R_{ON}	Output Switch-On Resistance	$I_{COL A}$ or $I_{COL B} = 0.75A$	●		0.5 0.85	Ω
$I_{LIM(MAX)}$	Maximum Current Limit Short-Circuit Current Limit	Duty Cycle = 15% Duty Cycle = 40%		1 0.8	1.25 1.8	A A
$\Delta I_{IN}/\Delta I_{SW}$	Supply Current Increase During Switch-On Time			16		mA/A
V_{DUTYTH}	DUTY Pin Threshold			0.35		

Slew Control

V_{SLEWR}	Output Voltage Slew Rising Edge	Either A or B, R_{VSL} , $R_{CSL} = 17k$		11		V/ μs
V_{SLEWF}	Output Voltage Slew Falling Edge	Either A or B, R_{VSL} , $R_{CSL} = 17k$		14.5		V/ μs
I_{SLEWR}	Output Current Slew Rising Edge	Either A or B, R_{VSL} , $R_{CSL} = 17k$		1.3		A/ μs
I_{SLEWF}	Output Current Slew Falling Edge	Either A or B, R_{VSL} , $R_{CSL} = 17k$		1.3		A/ μs

The ● denotes specifications that apply over the full operating temperature range.

Note 1: Absolute Maximum Ratings are those values beyond which the life of a device may be impaired.

Note 2: The LT1533 is designed to operate over the junction temperature range of $-40^\circ C$ to $125^\circ C$, but is neither tested nor guaranteed beyond $0^\circ C$ to $100^\circ C$ for C grade or $-40^\circ C$ to $100^\circ C$ for I grade.

TYPICAL PERFORMANCE CHARACTERISTICS

Minimum Input Voltage vs Temperature

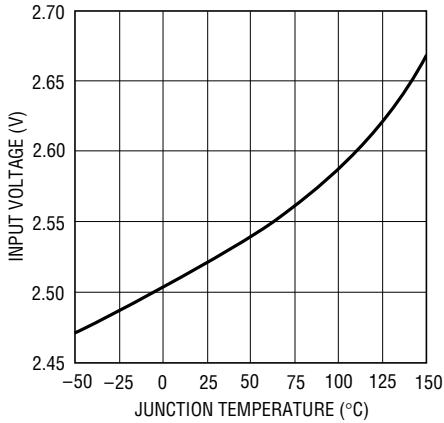

1533 G01

Change in I_{LIM} vs DC

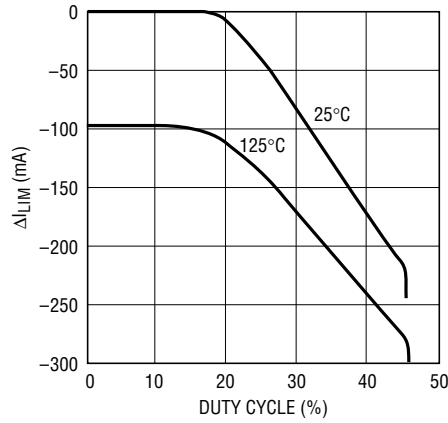

1533 G02

Switch Voltage Drop

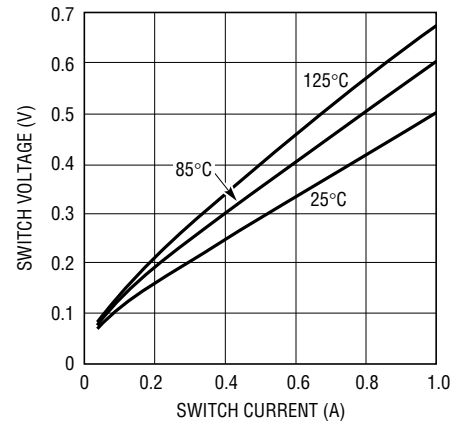

1533 G03

Feedback Voltage and Input Current vs Temperature

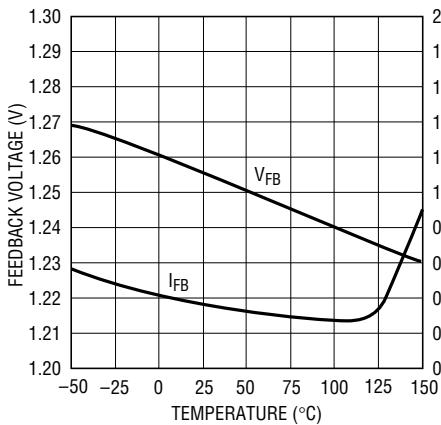

1533 G04

Negative Feedback Voltage and Input Current vs Temperature

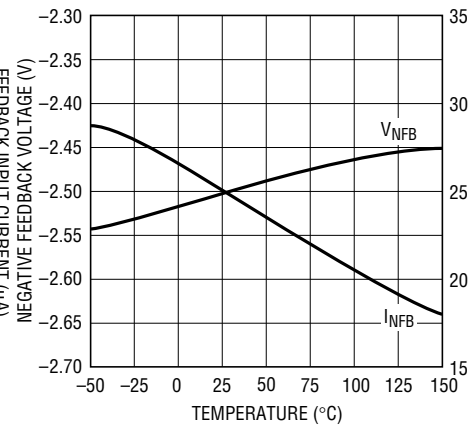

1533 G05

Error Amplifier Transconductance vs Temperature

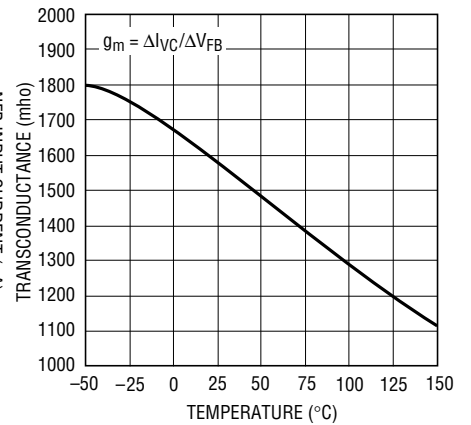

1533 G06

Switching Frequency vs Feedback Pin Voltage

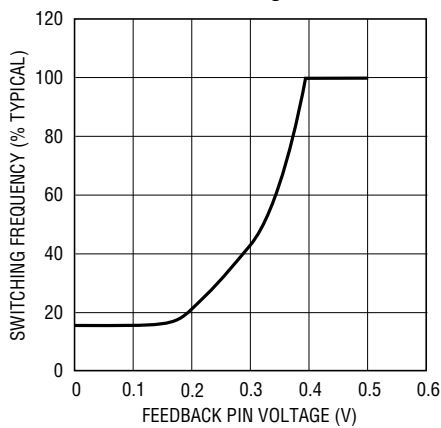

1533 G07

Error Amplifier Output Current

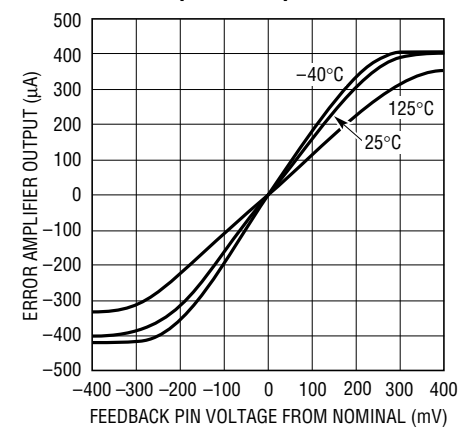

1533 G08

V_C Pin Threshold and Clamp Voltage vs Temperature

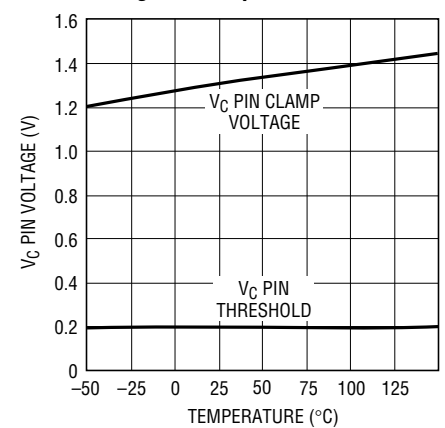

1533 G09

PIN FUNCTIONS

COL A, COL B (Pins 2, 15): These are the output collectors of the power switches. Their emitters return to PGND through a common sense resistor. COL A and COL B are alternately turned on out of phase. Large currents flow into these pins so it is desirable to keep external trace lengths short to minimize radiation. The collectors can be tied together for simple boost applications.

DUTY (Pin 3): Tying the DUTY pin to ground will force the outputs to switch with a 50% duty cycle. The DUTY pin must float if not used.

SYNC (Pin 4): The SYNC pin can be used to synchronize the oscillator to an external clock (see Oscillator Sync in Applications Information section for more details). The SYNC pin may either be floated or tied to ground if not used.

C_T (Pin 5): The oscillator capacitor pin is used in conjunction with R_T to set the oscillator frequency. For R_T = 16.9k,

$$C_{T(NF)} = 129/f_{OSC(kHz)}$$

R_T (Pin 6): The oscillator resistor pin is used to set the charge and discharge currents of the oscillator capacitor. The nominal value is 16.9k. It is possible to adjust this resistance $\pm 25\%$ to get a more accurate oscillator frequency.

FB (Pin 7): The feedback pin is used for positive voltage sensing and oscillator frequency shifting during start-up and short-circuit conditions. It is the inverting input to the error amplifier. The noninverting input of this amplifier connects internally to a 1.25V reference. This pin should be left open if not used.

NFB (Pin 8): The negative voltage feedback pin is used for sensing a negative output voltage. The pin is connected to the inverting input of the negative feedback amplifier through a 100k source resistor. The negative feedback amplifier provides a gain of -0.5 to the feedback amplifier. The nominal regulation point would be $-2.5V$ on NFB. This pin should be left open if not used.

GND (Pin 9): Signal Ground. The internal error amplifier, negative feedback amplifier, oscillator, slew control circuitry and the bandgap reference are referred to this ground. Keep the connection to the feedback divider and V_C compensation network free of large ground currents.

V_C (Pin 10): The compensation pin is used for frequency compensation and current limiting. It is the output of the error amplifier and the input of the current comparator. Loop frequency compensation can be performed with an RC network connected from the V_C pin to ground.

SHDN (Pin 11): The shutdown pin is used for disabling the switcher. Grounding this pin will disable all internal circuitry. Normally this output can be tied high (to V_{IN}) or may be left floating.

R_{CSL} (Pin 12): A resistor to ground sets the current slew rate for the collectors A and B. The minimum resistor value is 3.9k and the maximum value is 68k. Current slew will be approximately:

$$I_{SLEW(A/\mu S)} = 33/R_{CSL(k\Omega)}$$

R_{VSL} (Pin 13): A resistor to ground sets the voltage slew rate for the collectors A and B. The minimum resistor value is 3.9k and the maximum value is 68k. Voltage slew will be approximately:

$$V_{SLEW(V/\mu S)} = 220/R_{VSL(k\Omega)}$$

V_{IN} (Pin 14): Input Supply Pin. Bypass this pin with a $\geq 4.7\mu F$ low ESR capacitor. When V_{IN} is below 2.55V the part will go into undervoltage lockout where it will stop output switching and pull the V_C pin low.

PGND (Pin 16): Power Switch Ground. This ground comes from the emitters of the power switches. In normal operation this pin should have approximately 25nH inductance to ground. This can be done by trace inductance (approximately 1") or with wire or a specific inductive component. This inductance ensures stability in the current slew control loop during turn-off. Too much inductance ($> 50nH$) may produce oscillation on the output voltage slew edges.

BLOCK DIAGRAM

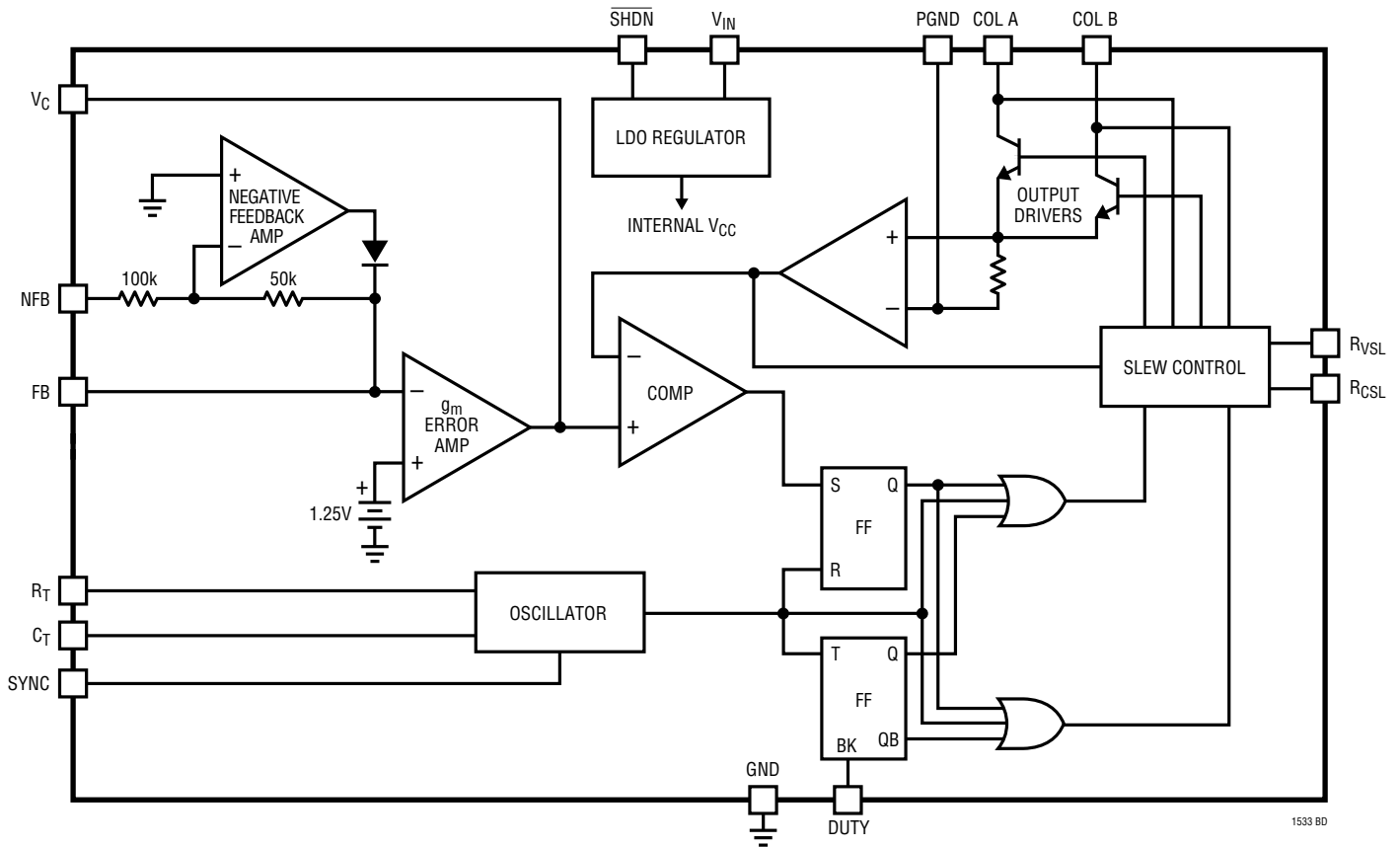

OPERATION

In noise sensitive applications, switching regulators tend to be ruled out as a power supply option due to their propensity for generating unwanted noise. When switching supplies are required due to efficiency or input/output voltage constraints, great pains must be taken to work around the noise generated by a typical supply. These steps may include precise synchronization of the power supply oscillator to an external clock, synchronizing the rest of the circuit to the power supply oscillator, or halting power supply switching during noise sensitive operations. The LT1533 greatly simplifies the task of eliminating supply noise by enabling the design of an inherently low noise switching regulator power supply.

The LT1533 is a fixed frequency, current mode switching regulator with unique circuitry to control the voltage and current slew rates of the output switches. Slew control capability provides much greater control over power sup-

ply components that can create conducted and radiated electromagnetic interference. The current mode control provides excellent AC and DC line regulation and simplifies loop compensation.

Current Mode Control

A switching cycle begins with an oscillator discharge pulse which resets the RS flip-flop, turning on one of the output drivers (refer to Block Diagram). The switch current is sensed across an internal resistor and the resulting voltage is amplified and compared to the output of the error amplifier (V_C pin). The driver is turned off once the output of the current sense amplifier exceeds the voltage on the V_C pin. The toggle flip-flop ensures that the two output drivers are enabled on alternate clock cycles. Internal slope compensation is provided to ensure stability under high duty cycle conditions.

OPERATION

Output regulation is obtained using the error amp to set the switch current trip point. The error amp is a transconductance amplifier that integrates the difference between the feedback output voltage and an internal 1.25V reference. The output of the error amp adjusts the switch current trip point to provide the required load current at the desired regulated output voltage. This method of controlling current rather than voltage provides faster input transient response, cycle by cycle current limiting for better output switch protection and greater ease in compensating the feedback loop.

The V_C pin serves three different purposes. It is used for loop compensation, current limit adjustment and soft starting. During normal operation the V_C voltage will be between 0.2V and 1.33V. An external clamp may be used for lowering the current limit. A capacitor coupled to an external clamp can be used for soft starting.

The negative voltage feedback amplifier allows for direct regulation of negative output voltages. The voltage on the NFB pin gets amplified by a gain of -0.5 and driven onto the FB input, i.e., the NFB pin regulates to $-2.5V$ while the amplifier output internally drives the FB pin to 1.25V as in normal operation. The negative feedback amplifier input impedance is 100k (typ) referred to ground.

Slew Control

Control of output voltage and current slew rates is done via two feedback loops. One loop controls the output switch collector voltage dV/dt and the other loop controls the emitter current dI/dt . Output slew control is achieved by comparing the currents generated by these two slewing events to currents created by external resistors R_{VSL} and

R_{CSL} . The two control loops are combined internally to provide a smooth transition from current slew control to voltage slew control.

Internal Regulator

Most of the control circuitry operates from an internal 2.4V low dropout regulator that is powered from V_{IN} . The internal low dropout design allows V_{IN} to vary from 2.7V to 23V with virtually no change in device performance. When the part is put into shutdown, the internal regulator is turned off, leaving only a small (12 μ A typ) current drain from V_{IN} .

Protection Features

There are three modes of protection in the LT1533. The first is overcurrent limit. This is achieved via the clamping action of the V_C pin. The second is thermal shutdown that disables both output drivers and pulls the V_C pin low in the event of excessive chip temperature. The third is under-voltage lockout that also disables both outputs and pulls the V_C pin low whenever V_{IN} drops below 2.5V.

50% Duty Cycle Mode

Since the LT1533 has dual out-of-phase outputs, it is ideal for driving push-pull transformers. For simple DC transformer applications, the part can be forced into a 50% duty cycle mode using the DUTY pin. Grounding the DUTY pin will override the internal control circuitry and force the outputs to switch with a 50% duty cycle at one-half the oscillator frequency. Slew control also applies in the 50% duty cycle mode.

APPLICATIONS INFORMATION

Reducing EMI from switching power supplies has traditionally invoked fear in designers. Many switchers are designed solely on efficiency and as such produce waveforms filled with high frequency harmonics that then propagate through the rest of the power supply.

The LT1533 provides control over two of the more important variables for controlling EMI with switching inductive

loads: switch voltage slew rate and switch current slew rate. The use of this part will reduce noise and EMI over conventional switch mode controllers. Because these variables are under control, a supply built with this part will exhibit far less tendency to create EMI and less chance of wandering into problems during production.

APPLICATIONS INFORMATION

It is beyond the scope of this data sheet to get into EMI fundamentals. AN70 contains much information concerning noise in switching regulators and should be consulted.

Oscillator Frequency

The oscillator determines the switching frequency and therefore the fundamental positioning of all harmonics. The use of good quality external components is important to ensure oscillator frequency stability. The oscillator is a sawtooth design. A current defined by external resistor R_T is used to charge and discharge the capacitor C_T . The discharge rate is approximately ten times the charge rate.

By allowing the user to have control over both components, trimming of oscillator frequency can be more easily achieved.

The external capacitance C_T is chosen by:

$$C_{T(nF)} = 2180 / [f_{OSC(kHz)} \cdot R_{T(k\Omega)}]$$

where f_{OSC} is the desired oscillator frequency in kHz.

For R_T equal to 16.9k, this simplifies to:

$$C_{T(nF)} = 129 / f_{OSC(kHz)},$$

e.g., $C_T = 1.29nF$ for $f_{OSC} = 100kHz$

Nominally R_T should be 16.9k. Since it sets up current, its temperature coefficient should be selected to compliment the capacitor. Ideally, both should have low temperature coefficients.

When the DUTY pin is high or floating, the outputs will be turned off during the discharge time of the oscillator. Due to slew rate control, turning off the outputs does not produce immediate transitions. Turn-off will require the current to ramp down and the switch voltage to ramp up. If the DUTY pin is grounded, then the outputs will turn on or off starting with the clock discharge.

If the FB pin is below 0.4V the oscillator discharge time will increase, causing the oscillation frequency to decrease by approximately 6:1. This feature helps minimize power dissipation during start-up and short-circuit conditions.

Oscillator frequency is important for noise reduction in two ways: 1) the lower the oscillator frequency the lower the harmonics of waveforms are, making it easier to filter

them, 2) the oscillator will control the placement of output frequency harmonics which can aid in specific problems where you might be trying to avoid a certain frequency bandwidth that is used for detection elsewhere.

Oscillator Sync

If a more precise frequency is desired (e.g., to accurately place harmonics) the oscillator can be synchronized to an external clock. Set the RC timing components for an oscillator frequency 10% lower than the desired sync frequency.

Drive the SYNC pin with a square wave (with greater than 1.4V amplitude). The rising edge of the sync square wave will initiate clock discharge. The sync pulse should have a minimum pulse width of 0.5 μ s.

Be careful in sync'ing to frequencies much different from the part since the internal oscillator charge slope determines slope compensation. It would be possible to get into subharmonic oscillation if the sync doesn't allow for the charge cycle of the capacitor to initiate slope compensation. In general, this will not be a problem until the sync frequency is greater than 1.5 times the oscillator free-run frequency.

Slew Rate Setting

Setting the voltage and current slew rates is easy. External resistors to ground on the R_{VSL} and R_{CSL} pins determine the slew rates. Determining what slew rate to use is more difficult. There are several ways to approach the problem.

First, start by putting a 50k resistor pot with a 3.9k series resistance on each pin. In general, the next step will be to monitor the noise that you are concerned with. Be careful with measurement technique (consult AN70). Keep probe ground leads very short.

Usually it will be desirable to keep the voltage and current slew resistors approximately the same. There are circumstances where a better optimization can be found by adjusting each separately, but as these values are separated further, a loss of independence of control will occur.

Starting from the lowest resistor setting adjust the pots until the noise level meets your guidelines. Note that

APPLICATIONS INFORMATION

slower slewing waveforms will dissipate more power so that efficiency will drop. You can also monitor this as you make your slew adjustment by measuring input and output voltage and current.

It is possible to use a single slew setting resistor. In this case the R_{VSL} and R_{CSL} pins are tied together. A resistor with a value of 2k to 34k (one half the individual resistors) can then be tied from these pins to ground.

Emitter Inductance

A small inductance in the power ground minimizes a potential dip in the output current falling edge that can occur under fast slewing, 25nH is usually sufficient. Greater than 50nH may produce unwanted oscillations in the voltage output. The inductance can be created by wire or board trace with the equivalent of one inch of straight length. A spiral board trace will require less length.

Positive Output Voltage Setting

Sensing of a positive output voltage is usually done using a resistor divider from the output to the FB pin. The positive input to the error amp is connected internally to a 1.25V bandgap reference. The FB pin will regulate to this voltage.

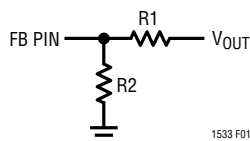

Figure 1

Referring to Figure 1, R1 is determined by:

$$R1 = R2 \left(\frac{V_{OUT}}{1.25} - 1 \right)$$

The FB bias current represents a small error and can usually be ignored for values of $R1 || R2$ up to 10k.

One word of caution. Sometimes a feedback zero is added to the control loop by placing a capacitor across R1 above. If the feedback capacitively pulls the FB pin above the

internal regulator voltage (2.4V typ), output regulation may be disrupted. A series resistance with the feedback pin can eliminate this potential problem.

Negative Output Voltage Setting

Negative output voltage can be sensed using the NFB pin. In this case regulation will occur when the NFB pin is at -2.5V. The input bias current for the NFB is $-25\mu A$ (I_{NFB}) which needs to be accounted for in setting up the divider.

Referring to Figure 2, R1 is chosen such that:

$$R1 = R2 \left(\frac{|V_{OUT}| - 2.5}{2.5 + R2 \cdot 25\mu A} \right)$$

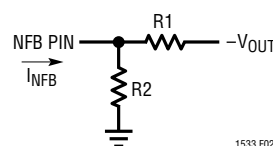

Figure 2

A suggested value for R2 is 2.5k. The NFB pin is normally left open if the FB pin is being used.

Dual Polarity Output Voltage Sensing

Certain applications may benefit from sensing both positive and negative output voltages. When doing this each output voltage resistor divider is individually set as previously described. When both FB and NFB pins are used, the LT1533 will act to prevent either output from going beyond its set output voltage. The highest output (lightest load) will dominate control of the regulator. This technique would prevent either output from going unregulated high at no load. However, this technique will also compromise output load regulation.

Shutdown

If the shutdown pin is pulled low, the regulator will turn off. The supply current will be reduced to less than 20 μA .

APPLICATIONS INFORMATION

Thermal Considerations

Computing power dissipation for this IC requires careful attention to detail. Reduced output slewing causes the part to dissipate more power than would occur with fast edges. However, much improvement in noise can be produced with modest decrease in supply efficiency.

Power dissipation is a function of topology, input voltage, switch current and slew rates. It is impractical to come up with an all-encompassing formula. It is therefore recommended that package temperature be measured in each application. The part has an internal thermal shutdown to prevent device destruction, but this should not replace careful thermal design.

1. Dissipation due to input current:

$$P_{VIN} = V_{IN} \left(11\text{mA} + \frac{I}{60} \right)$$

where I is the average switch current.

2. Dissipation due to the drivers saturation:

$$P_{VSAT} = (V_{SAT})(I)(DC_{MAX})$$

where V_{SAT} is the output saturation voltage which is approximately $0.1 + (0.4)(I)$, DC_{MAX} is the maximum duty cycle.

3. Dissipation due to output slew using approximations for slew rates:

$$P_{SLEW} = \left(\frac{(V_{IN}) \left(I^2 + \frac{\Delta I^2}{4} \right)}{(33)(10^9)} (R_{CSL}) + \frac{(I) \left(V_{IN}^2 - \frac{V_{SAT}^2}{4} \right)}{(220)(10^9)} (R_{VSL}) \right) (f_{OSC})$$

Note if V_{SAT} and ΔI are small with respect to V_{IN} and I , then:

$$P_{SLEW} = \left(\frac{(I)(R_{CSL})}{(33)(10^9)} + \frac{(V_{IN})(R_{VSL})}{(220)(10^9)} \right) (f_{OSC})(V_{IN})(I)$$

where ΔI is the ripple current in the switch, R_{CSL} and R_{VSL} are the slew resistors and f_{OSC} is the oscillator frequency.

Power dissipation P_D is the sum of these three terms. Die junction temperature is then computed as:

$$T_J = T_{AMB} + (P_D)(\theta_{JA})$$

where T_{AMB} is ambient temperature and θ_{JA} is the package thermal resistance. For the 16-pin SO θ_{JA} is $100^\circ\text{C}/\text{W}$.

For example, with $f_{OSC} = 40\text{kHz}$, $V_{IN} = 10\text{V}$, 0.4A average current and 0.1A of ripple, the maximum duty cycle is 44%. Assume slew resistors are both 17k and V_{SAT} is 0.26V , then:

$$P_D = 0.176\text{W} + 0.094\text{W} + 0.158\text{W} = 0.429\text{W}$$

In an S16 package the die junction temperature would be 43°C above ambient.

Frequency Compensation

Loop frequency compensation is accomplished by way of a series RC network on the output of the error amplifier (V_C pin). Referring to Figure 3, the main pole is formed by capacitor C_{VC} and the output impedance of the error amplifier (approximately $400\text{k}\Omega$). The series resistor R_{VC} creates a "zero" which improves loop stability and transient response. A second capacitor C_{VC2} , typically one-tenth the size of the main compensation capacitor, is sometimes used to reduce the switching frequency ripple on the V_C pin. V_C pin ripple is caused by output voltage ripple attenuated by the output divider and multiplied by the error amplifier. Without the second capacitor, V_C pin ripple is:

$$V_C \text{ PIN RIPPLE} = \frac{(1.25)(V_{RIPPLE})(g_m)(R_{VC})}{V_{OUT}}$$

where V_{RIPPLE} = Output ripple (V_{P-P})
 g_m = Error amplifier transconductance
 R_{VC} = Series resistor on V_C pin
 V_{OUT} = DC output voltage

APPLICATIONS INFORMATION

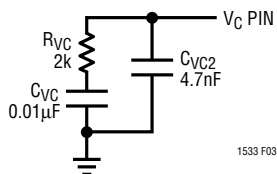

Figure 3

To prevent irregular switching, V_C pin ripple should be kept below 50mV_{p-p}. Worst-case V_C pin ripple occurs at maximum output load current and will also be increased if poor quality (high ESR) output capacitors are used. The addition of a 0.0047µF capacitor on the V_C pin reduces switching frequency ripple to only a few millivolts. A low value for R_{V_C} will also reduce V_C pin ripple, but loop phase margin may be inadequate.

Magnetics

Design of magnetics is dependent on topology. The following details the design of the magnetics for a push-pull converter. In this converter the transformer usually stores little energy. The following equations should be considered as the starting point to building a prototype.

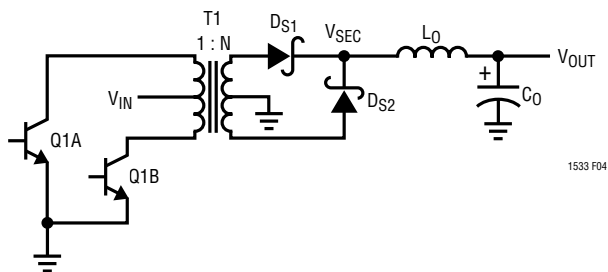

Figure 4

The following definitions will be used:

- V_{IN} = Input supply voltage
- V_{SW} = Switch-on voltage
- V_{OUT} = Desired output voltage
- I_{OUT} = Output current
- f = Oscillator frequency
- V_F = Forward drop of the rectifier

Duty cycle is the major defining equation for this topology. Note that the output L and C basically filter the chopped voltage so duty cycle controls output voltage. N is the

turns ratio of the transformer. The turns ratio must be large enough to ensure that the transformer can put out a voltage equal to the output voltage plus the diode under minimum input conditions.

$$N = \frac{V_{OUT} + V_F}{2 \cdot DC_{MAX} (V_{IN(MIN)} - V_{SW})}$$

DC_{MAX} is the maximum duty cycle of each driver with respect to the entire cycle which consists of two periods (Q1A on and Q1B on). So the effective duty cycle is $2 \cdot DC_{MAX}$. The controller, in general, determines maximum duty cycle. A 44% maximum duty cycle is a guaranteed value for this part.

Some Common Turns Ratios

V_{IN}	V_{OUT}	N
5 ±10%	12	3.6
5 ±10%	15	4.4
5 ±10%	3.3	1.1

Remember to add sufficient margin in the turns ratio to account for IR drops in the transformer windings, worst-case diode forward drop (V_F) and switch-on voltage (V_{SW}).

There are a number of ways to choose the inductance value for L_0 . We suggest as a starting point that L_0 be selected such that the converter is continuous at $I_{OUT(MAX)}/4$. If your minimum I_{OUT} is higher than this, or you are operating at low currents such that the IC and components can handle higher peak currents, then use a higher number.

Continuous operation occurs when the current in the inductor never goes to zero. Discontinuous operation occurs when the inductor current drops to zero before the start of the next cycle and can occur with small inductors and light loads. There is nothing inherently bad about discontinuous operation, however, the converter control and operation is somewhat different. The inductor is smaller for discontinuous operation but the peak currents in the switch, the transformer, the diodes, inductor and capacitor will be higher. But for low power situations these may not present a big constraint.

APPLICATIONS INFORMATION

For continuous operation the inductor ripple current must be less than twice the output current. The worst case for this is at maximum input (lowest DC) but we will evaluate at nominal input since the $I_{OUT}/4$ is somewhat arbitrary. Note when both inputs are off, inductor current splits between outputs and the diode common goes to 0V. Looking at the inductor current during off time, output ripple current is:

$$\Delta I_{OUT} = 2 \cdot I_{OUT(MIN)}$$

$$I_{OUT(MIN)} = I_{OUT(MAX)}/4$$

$$L_0 = \frac{V_{OUT}(1 - 2 \cdot DC_{NOM})}{\Delta I_{OUT} \cdot f}$$

The inductance of the transformer primary should be such that L_0 , when reflected into the primary, dominates the input current. In other words, we want the magnetizing current of the transformer small with respect to the current going through the transformer to L_0 . In general, then, the inductance of the primary should be at least five times that of L_0 . This ensures that most of the power will be passed through the transformer to the load. It also increases the power capability of the converter and reduces the peak currents that the switch will see.

$$L_{PRI} = 5 \cdot L_0/N^2$$

If the magnetizing current is below 100mA, then a smaller L_0 can be used.

With the value of L_0 set, the ripple in the inductor is:

$$\Delta I_{OUT} = \frac{V_{OUT}(1 - 2 \cdot DC)}{L_0 \cdot f}$$

However, the peak inductor current is evaluated at maximum load and maximum input voltage (minimum DC).

$$I_{LMAX} = I_{OUT(MAX)} + \frac{\Delta I_{OUT(MAX)}}{2}$$

The magnetizing ripple current can be shown to be:

$$\Delta I_{MAG} = \frac{V_{OUT} + V_F}{N \cdot L_{PRI} \cdot f}$$

and the peak current in the switch is:

$$I_{SW(PEAK)} = N \cdot I_{LMAX} + \Delta I_{MAG}$$

This should be less than the 1A current limit.

In the push-pull converter the maximum switch voltage will be $2 \cdot (V_{IN} - V_{SW})$ plus a small amount (10%) for leakage spikes. Because voltage is slew-controlled, the spikes will be less than normal. So, maximum switch voltage is:

$$V_{SW(MAX)} = 2 \cdot V_{IN} \cdot 1.1$$

This should be below the maximum rated switch voltage.

So, given the turns ratio, primary inductance and current, the transformer can be designed. As an example:

$V_{IN} = 5V \pm 10\%$, $V_{OUT} = 12V$, $I_{OUT(MAX)} = 150mA$, $V_{SW} = 0.5V$, $V_F = 0.5V$, $f = 50kHz$,

$$N = \frac{12 + 0.5}{(2 \cdot 0.44)(4.5 - 0.5)} = 3.55$$

Round up so $N = 3.6$.

For continuous operation at $I_{OUT(MIN)} = I_{OUT(MAX)}/4$, inductor ripple is:

$$\Delta I_{OUT} = 2 \cdot \frac{150mA}{4} = 75mA$$

The duty cycle for nominal input is:

$$DC_{NOM} = \frac{V_{OUT} + V_F}{(2 \cdot N)(V_{IN(NOM)} - V_{SW})}$$

$$= \frac{12 + 0.5}{(2 \cdot 3.6)(5 - 0.5)} = 38.6\%$$

$$L_{0(MIN)} = \frac{12(1 - 2 \cdot 38.6\%)}{75mA \cdot 50kHz} = 730\mu H$$

Off-the-shelf components can be used for this inductor. Say we found an 800 μH inductor (Coiltronics CTX200-1 for instance).

APPLICATIONS INFORMATION

Output ripple current at maximum input (DC = 34.7%) is:

$$\Delta I_{OUT} = \frac{12(1 - 2 \cdot 34.7\%)}{800\mu\text{H} \cdot 50\text{kHz}} = 92\text{mA}$$

The maximum inductor current is:

$$I_{LMAX} = 150\text{mA} + \frac{92\text{mA}}{2} = 196\text{mA}$$

Primary inductance should be greater than:

$$L_{PRI} = \frac{5 \cdot 800\mu\text{H}}{3.6^2} = 309\mu\text{H}$$

The magnetizing ripple current is approximately:

$$\Delta I_{MAG} = \frac{12 + 0.5}{3.6 \cdot 309\mu\text{H} \cdot 50\text{kHz}} = 225\text{mA}$$

Peak switch current is:

$$I_{SW(PEAK)} = 3.6 \cdot 196\text{mA} + 225\text{mA} = 930\text{mA}$$

which is less than the 1A maximum switch current.

Note that you can discern your magnetizing ripple by looking at the reflected inductance ripple and subtracting the switch current ripple.

$$\Delta I_{MAG} = N \cdot \Delta I_L - \Delta I_{SW}$$

With knowledge of turns ratio and primary inductance along with volt/sec requirements (to prevent saturation) the transformer can be designed.

Transformers are available from Coiltronics for some standard applications. Figure 5 lists them. Variations are available from Coiltronics at 561-241-7876. Also, see Linear Technology's Application Notes AN19, AN44 and AN70 for further information about magnetics.

Capacitors

Correct choice of input and output capacitors can be very important to low noise switcher performance. Push-pull topologies and other low noise topologies will in general have continuous currents which reduce the requirements

NOMINAL INPUT VOLTAGE	NOMINAL OUTPUT VOLTAGE AFTER LINEAR REGULATOR	OUTPUT POWER	COILTRONICS PART NUMBER	CONNECTION DIAGRAM
5V	12V	1.5W	CTX02-13716-X1	A
5V	12V	3.0W	CTX02-13665-X1	A
5V	±15V	1.5W	CTX02-13713-X1	B
5V	±15V	3.0W	CTX02-13664-X1	B
5V	12V	1.5W	CTX02-13834-X3*	A
5V	12V	10W	CTX02-13949-X1	A

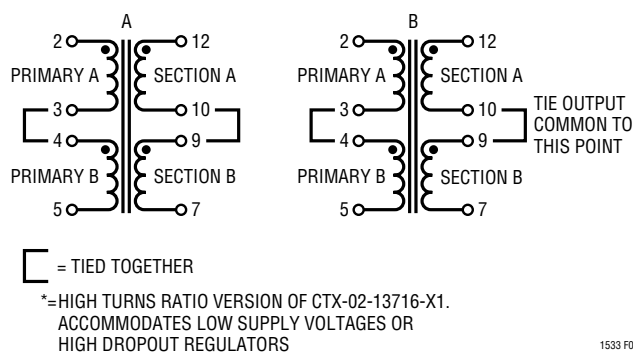

Figure 5. Transformers for Typical Applications

for capacitance. However, noise depends more on the ESR of the capacitors.

Input capacitors must also withstand surges that occur during the switching of some types of loads. Some solid tantalum capacitors can fail under these surge conditions.

Design Note 95 offers more information but the following is a brief summary of capacitor types and attributes.

Aluminum Electrolytic: Low cost and higher voltage but in general don't use with this part because of high ESR and poor high frequency performance.

Specialty Polymer Aluminum: Panasonic has come out with their series CD capacitors. While they are only available for voltages below 16V, they have very low ESR and good surge capability.

Solid Tantalum: Small size and low impedance. Typically available for voltages below 50V. Possible problem with surge currents (AVX TPS line addresses this issue).

OS-CON: Lower impedance than aluminum but only available for 25V or less. Form factor may be a problem. Sometimes their very low ESR can cause loop stability problems.

APPLICATIONS INFORMATION

Ceramic: Generally used for high frequency and high voltage bypass. If all ceramic capacitors are used, they can have such a low ESR as to cause loop stability problems. Often they can resonate with their ESL before ESR becomes effective.

Input Capacitor

The requirements for the input capacitor are less stringent for this part. Input current ripple is lower because of the push-pull action and low noise features of the part. However, the input capacitor should have low ESR at high frequencies since this will be an important factor concerning how much conducted noise is created. Values of input capacitor will typically be in the 1 μ F to 22 μ F range with ESR under 0.3 Ω .

The input capacitor can see a high surge current when a battery of high capacitance source is connected “live.” Some solid tantalum capacitors can fail under this condition. Several manufacturers have developed a line of solid tantalum capacitors specially tested for surge capability (e.g., AVX TPS series). However, even these units may fail if the input voltage approaches the maximum voltage rating of the capacitor. AVX recommends derating capacitor voltage by 2:1 for high surge applications.

Output Filter Capacitor

Output capacitors are usually chosen on the basis of ESR since this will determine output ripple. Typical required ESR will be in the 0.05 Ω to 0.3 Ω range.

The specific value for capacitance will depend on topology. A typical output capacitor is an AVX type TPS, 22 μ F and 25V with a guaranteed ESR less than 0.2 Ω . To further reduce ESR, multiple output capacitors can be used in parallel. The value in microfarads is not particularly important. A small 22 μ F tantalum capacitor will have high ESR and higher output voltage ripple. Table 1 shows some typical surface mount capacitors.

Table 1

SIZE	CAPACITOR	ESR (MAX Ω)
E CASE	AVX TPS, Sprague 593D	0.1 to 0.3
	AVX TAJ	0.7 to 0.9
D CASE	AVX TPS, Sprague 593D	0.1 to 0.3
	AVX TAJ	0.9 to 2.0
	Panasonic CD	0.05 to 0.18
C CASE	AVX TPS	0.2 (Typ)
	AVX TAJ	1.8 to 3.0
B CASE	AVX TAJ	2.5 to 10

Switching Diodes

In general, switching diodes should be Schottky diodes such as 1N5818 or MBR130 (1A/30V). Low output current applications may use 1N4148 switching diodes.

Unregulated Applications

The LT1533 can be used to create a low noise “DC transformer” unregulated power supply. DC transformers are open-loop switching regulators where the output voltage is controlled by the turns ratio of the transformer. A DC transformer provides a low cost isolated supply.

For such applications, the DUTY pin of the LT1533 should be grounded. This will force the outputs into a 50% on, 50% off mode. Note that because of slew control there will be some variance from 50%. Figure 6 shows a 5V to \pm 12V DC transformer.

One concern with this type of application is having both switch outputs transition at the same time. This can cause both primary side windings to have positive EMF added to the winding, causing the current to run away. Since this part controls slew rate this won't happen. It is possible to see slightly increased total current draw when both drivers are on, but this will be controlled and observable. Since the outputs share a common sense resistor, the outputs will turn off when the total current in both exceeds the limit set by the V_C pin.

The FB pin should be DC biased between 0.7V and 1.2V to prevent frequency shifting from occurring. This also ensures that the V_C pin is set to its upper clamp, providing peak output current.

APPLICATIONS INFORMATION

The slew rate adjustment should be made by putting a 3.9k resistor in series with a 50k pot on the R_{VSL} and R_{CSL} pins (or a 2k resistor in series with a 25k pot with both pins tied together). Monitor output noise or other system signal while increasing the resistance until desired noise performance is reached. System efficiency can also be monitored.

While this topology is not as quiet as a push-pull converter, it can provide a low cost, isolated power supply that has decreased noise relative to other solutions.

More Help

AN70 contains much information concerning LT1533 applications and measurement of noise and should be consulted. A 5V to 12V demo board is also available (DC173). AN19 and AN29 also have general knowledge concerning switching regulators. Our Application Department is always ready to lend a helping hand.

TYPICAL APPLICATIONS

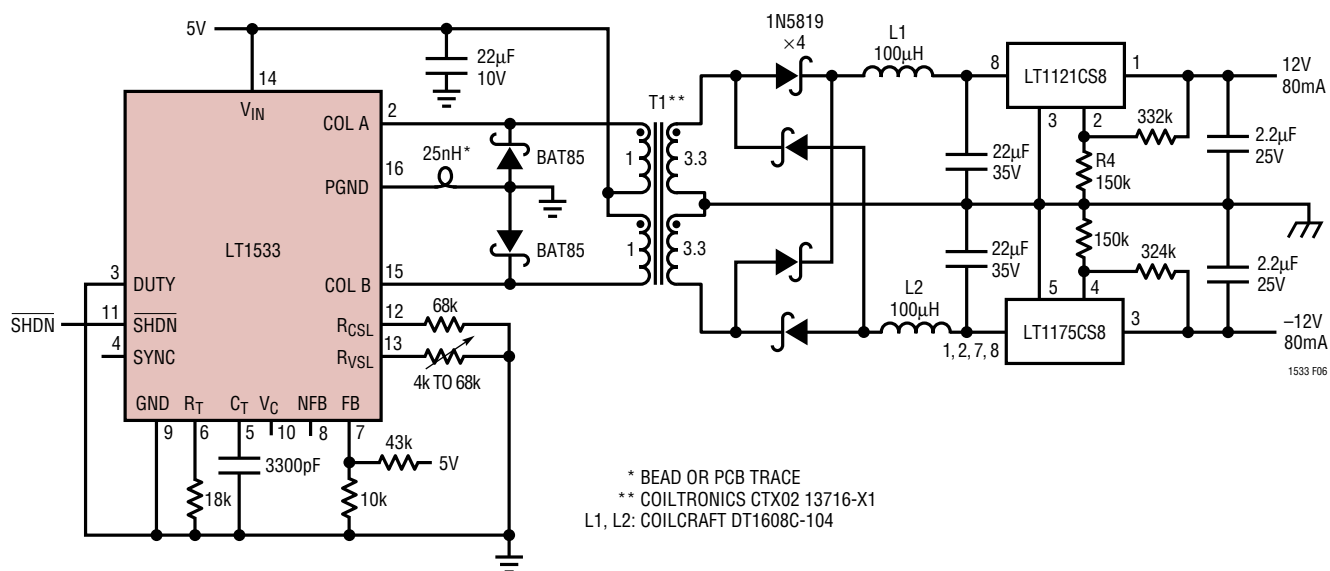
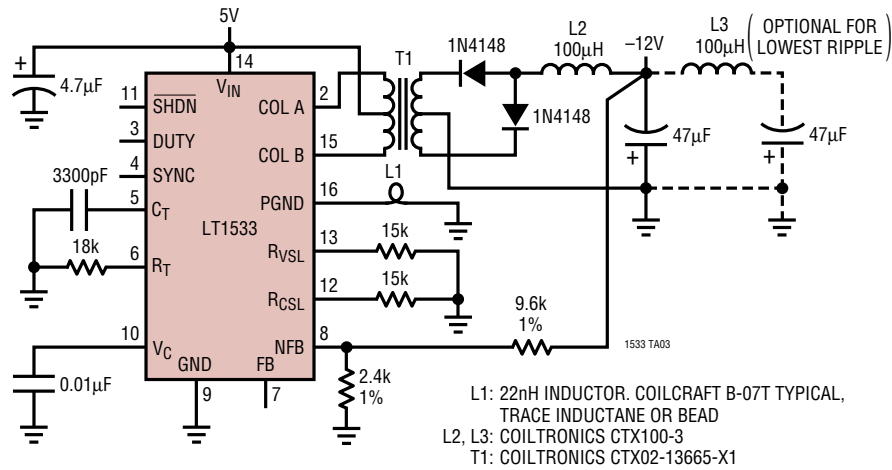

Figure 6. 5V to ±12V DC Transformer

TYPICAL APPLICATIONS

Low Noise 5V to -12V Forward Push-Pull Converter. Output Noise Is Below 100 μ V. Noise Performance Is Identical to Positive Output Version. See AN70 for Details



Electronic Equivalent of 9V Battery Operates from Three NiCd Cells. Output Noise Is Below 100 μ V. See AN70 for Details

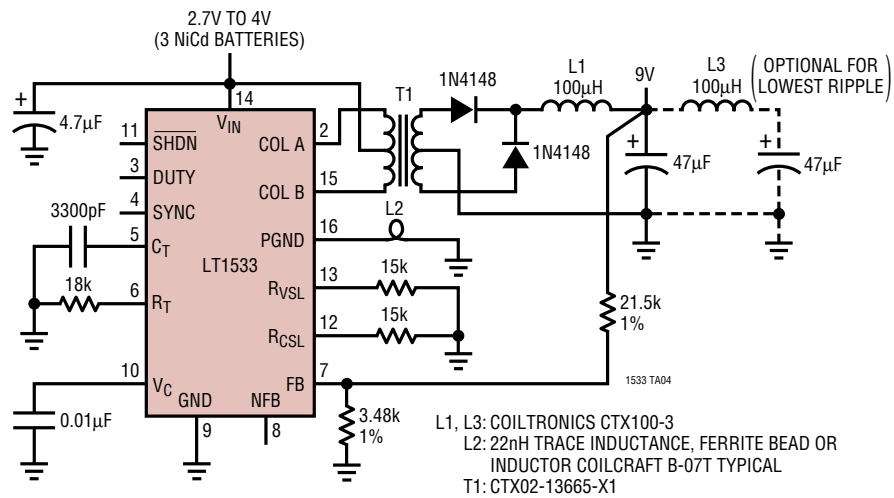

TYPICAL APPLICATIONS

Hysteretic Loop Lowers Quiescent Current to 100µA While Maintaining Low Output Noise. See AN70 for Details

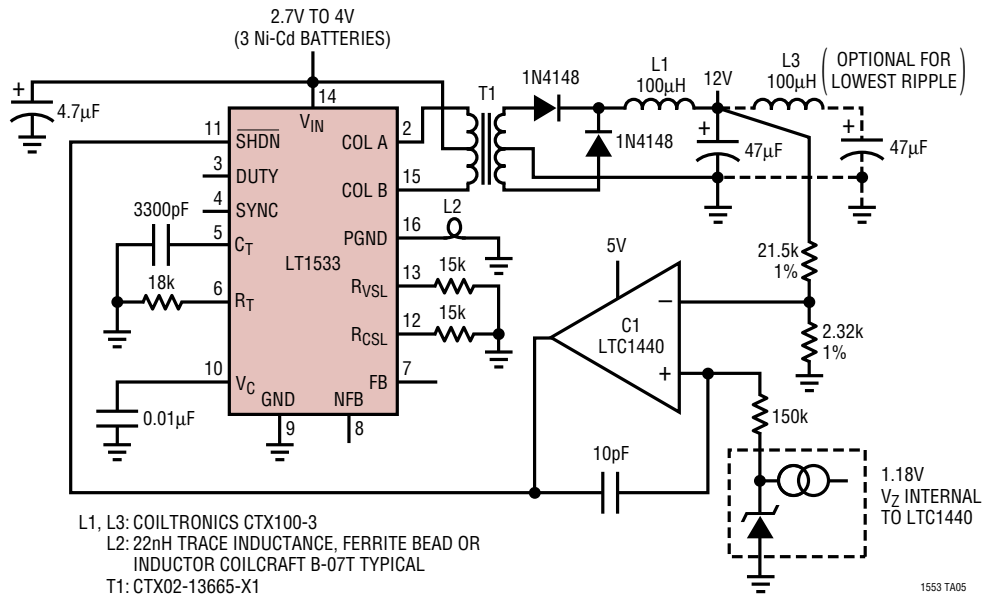

A 50V Output Low Noise Regulator. Cascoded Bipolar Transistors Accommodate 60V Transformer Swings, Permitting 24V (20V_{IN} to 30V_{IN}) Powered Operation. See AN70 for Details

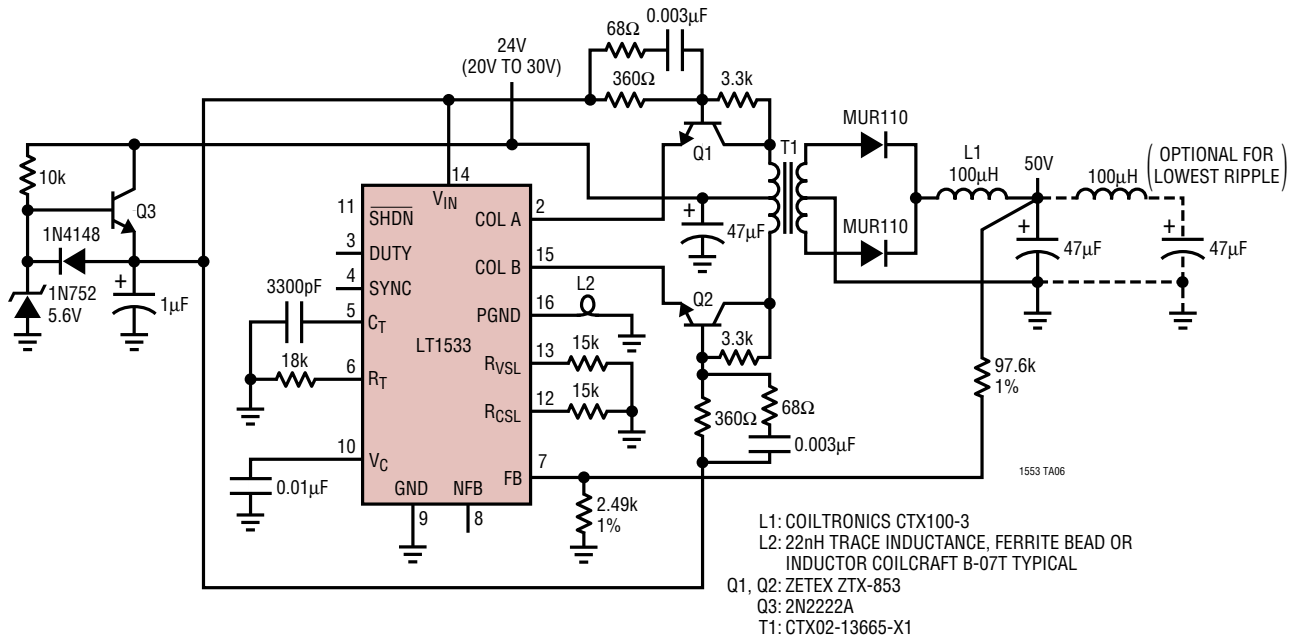

TYPICAL APPLICATIONS

A 10W Low Noise 5V to 12V Converter. Q1-Q2 Provide 5A Output Capacity While Preserving LT1533's Voltage Current Slew Control. Efficiency Is 68%. Higher Input Voltages Minimize Follower Loss, Boosting Efficiency Above 71%. See AN70 for Details

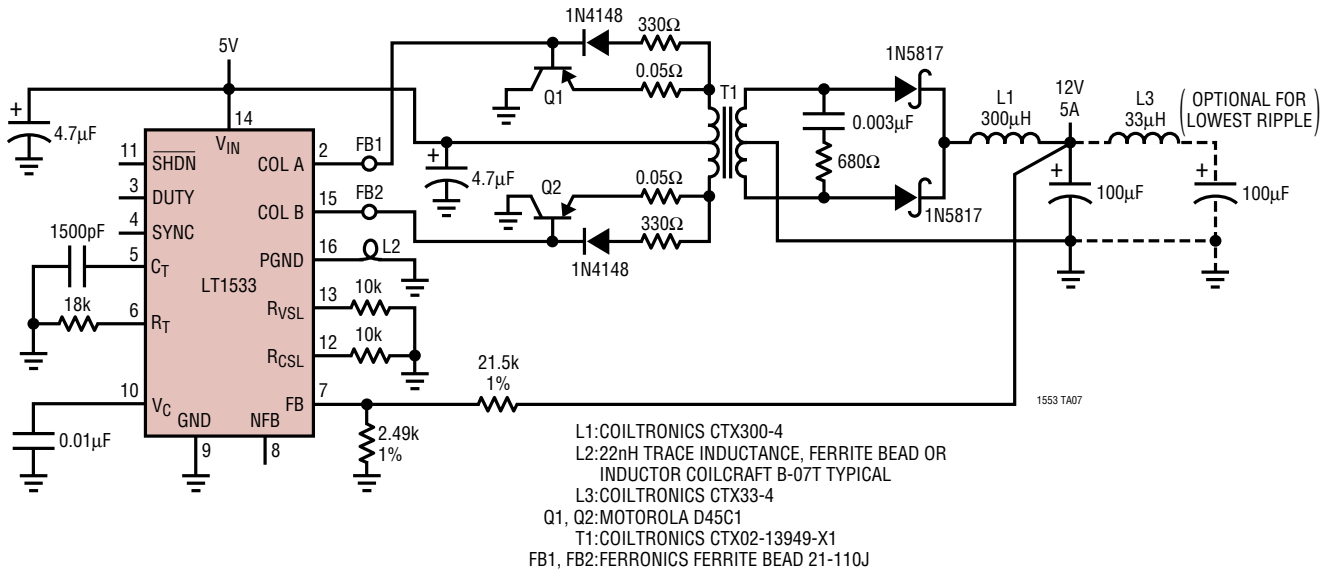

PACKAGE DESCRIPTION Dimensions in inches (millimeters) unless otherwise noted.

S Package
16-Lead Plastic Small Outline (Narrow 0.150)
 (LTC DWG # 05-08-1610)

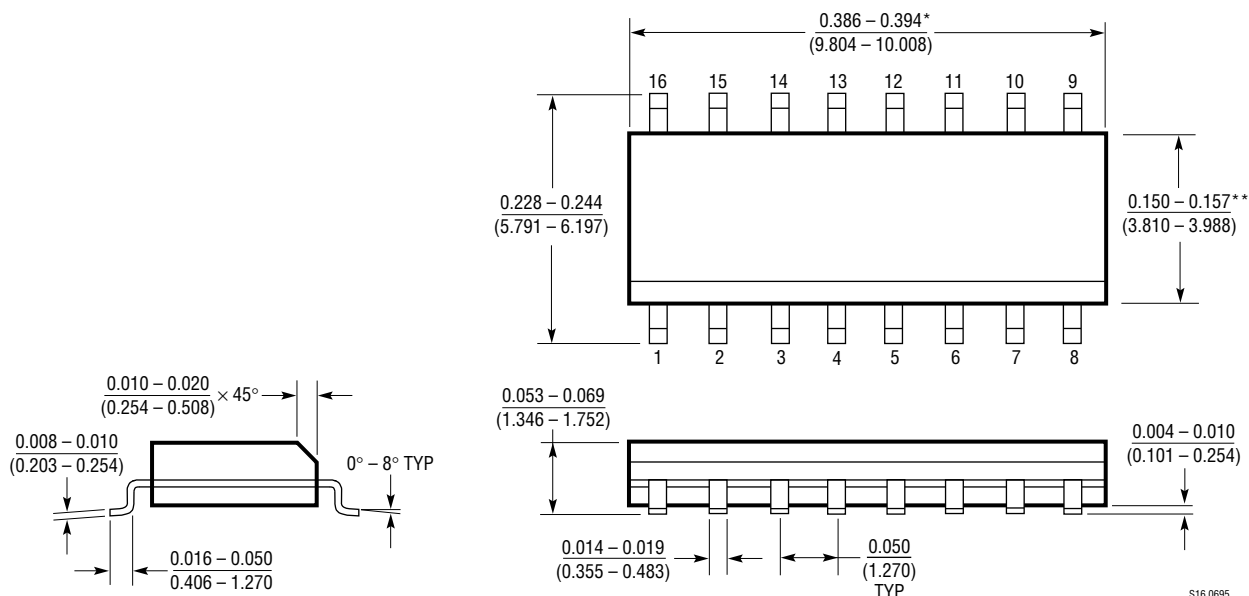

* DIMENSION DOES NOT INCLUDE MOLD FLASH. MOLD FLASH SHALL NOT EXCEED 0.006" (0.152mm) PER SIDE
 ** DIMENSION DOES NOT INCLUDE INTERLEAD FLASH. INTERLEAD FLASH SHALL NOT EXCEED 0.010" (0.254mm) PER SIDE

S16 0695

TYPICAL APPLICATION

10W Off-Line Power Supply Passes FCC Emission Requirements Without Filter Components

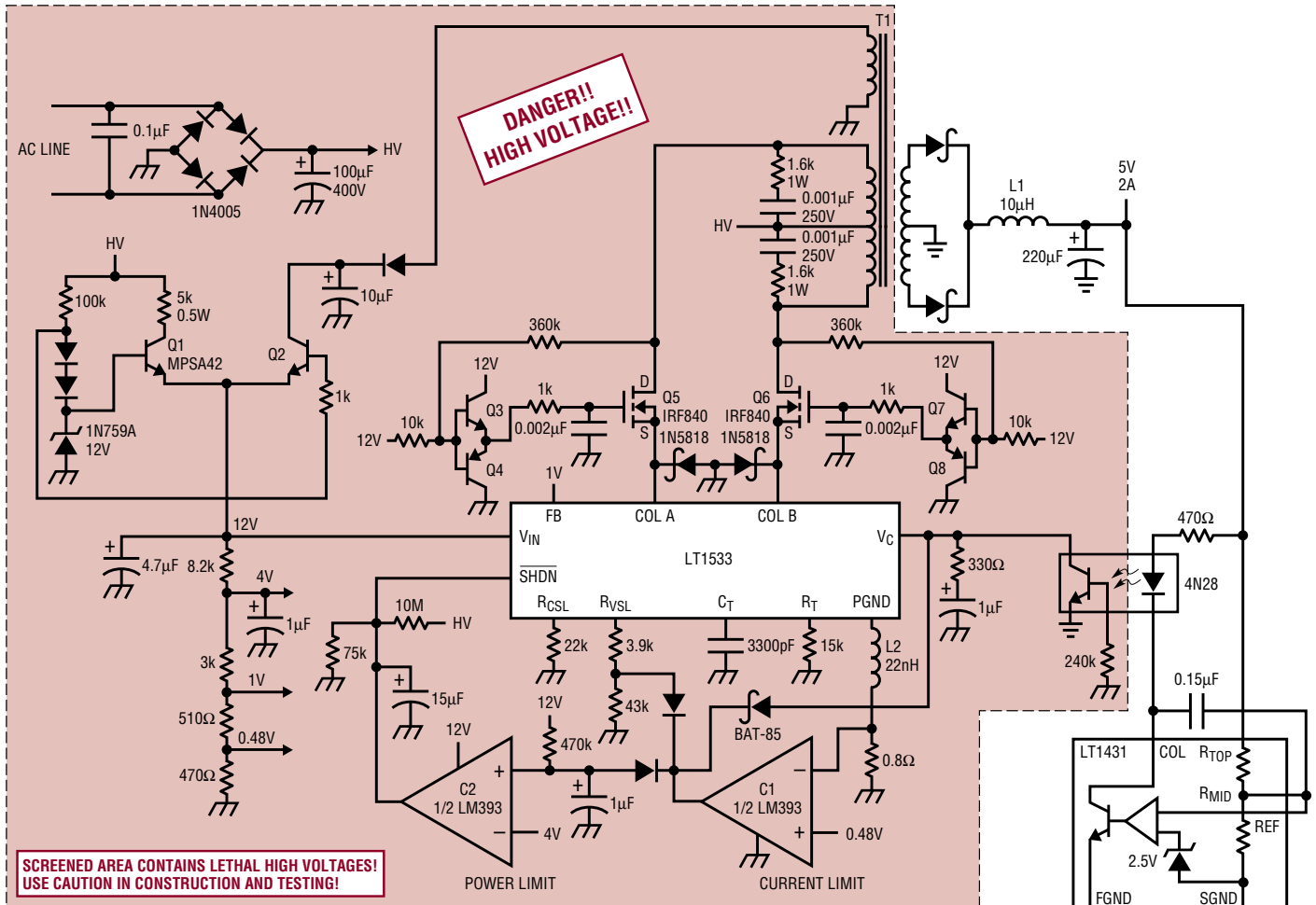

L1 = COILTRONICS UP-4
 L2 = COILCRAFT B07T
 NPN = 2N3904 UNLESS OTHERWISE NOTED
 PNP = 2N3906
 T1 = COILTRONICS CTX02-13978-X3

= 20CJQ045(I.R.) UNLESS OTHERWISE NOTED
 = AC (HOT) RETURN
 = 1N4148
 = OUTPUT COMMON

RELATED PARTS

PART NUMBER	DESCRIPTION	COMMENTS
LT1129	700mA Micropower Low Dropout Regulator	0.4V Dropout Voltage, Reverse Battery Protection
LT1175	500mA Negative Low Dropout Micropower Regulator	Positive or Negative Shutdown Logic
LT1377	1MHz High Efficiency 1.5A Switching Regulator	High Frequency, Small Inductor
LT1425	Isolated Flyback Switching Regulator	Excellent Regulation Without Transformer "Third Winding"
LTC®1436	High Efficiency Synchronous Switching Regulator	Adaptive Power™ Mode, Phase Locked Loop
LT1534	Ultralow Noise 2A Switching Regulator	Ultralow Noise Regulator for Boost Topologies

Adaptive Power is a trademark of Linear Technology Corporation.