

Constant-Current/ Constant-Voltage Battery Chargers with Preset Voltage and Termination Flag

FEATURES

- Fast Charging of Li-Ion, NiMH and NiCd Batteries
- Simple Charge Current Programming Requires Only One Low Cost, 1/32W Resistor
- High Efficiency Charger with Up to 1.5A Charge Current
- Precision 0.6% Internal Voltage Reference
- Preset Battery Voltages: 4.1V, 4.2V, 8.2V, 8.4V
- 500kHz or 200kHz Switching Frequency Minimizes Charger Size
- Low Reverse Battery Drain Current: 5 μ A
- Flag Indicates Li-Ion Charge Completion
- 5% Typical Charge Current Accuracy
- Low Shutdown Current
- LT1571-1: 200kHz, Adjustable Voltage
 LT1571-2: 200kHz, Fixed 8.2V or 8.4V
 LT1571-5: 500kHz, Fixed 4.1V or 4.2V

APPLICATIONS

- Cellular Phones, PDAs, Notebook Computers, Portable Instruments
- Cradle Chargers for Li-Ion, NiCd, NiMH and Lead-Acid Rechargeable Batteries

DESCRIPTION

The LT[®]1571 PWM battery charger is a simple, efficient solution to fast-charge rechargeable batteries including lithium-ion (Li-Ion), nickel-metal-hydride (NiMH) and nickel-cadmium (NiCd) using constant-current and/or constant-voltage control. The internal switch is capable of delivering 1.5A DC current (2A peak current). The onboard current sense resistor (0.1 Ω) allows simple charge current programming to within 5% accuracy using a low cost external resistor. The constant-voltage output can be selected for 4.1V or 4.2V per cell with 0.6% accuracy.

LT1571 can charge batteries ranging from 1V to 20V. A saturating switch operating at 200kHz (LT1571-1, LT1571-2) or 500kHz (LT1571-5) gives high efficiency and small charger size. A logic output (flag) indicates Li-Ion near full charge when the charge current drops to 20% of the programmed value. The LT1571-1 and LT1571-2 are in a 28-pin fused lead narrow SSOP power package. The LT1571-5 is in a 16-pin fused lead narrow SSOP power package.

 LTC and LT are registered trademarks of Linear Technology Corporation.

TYPICAL APPLICATION

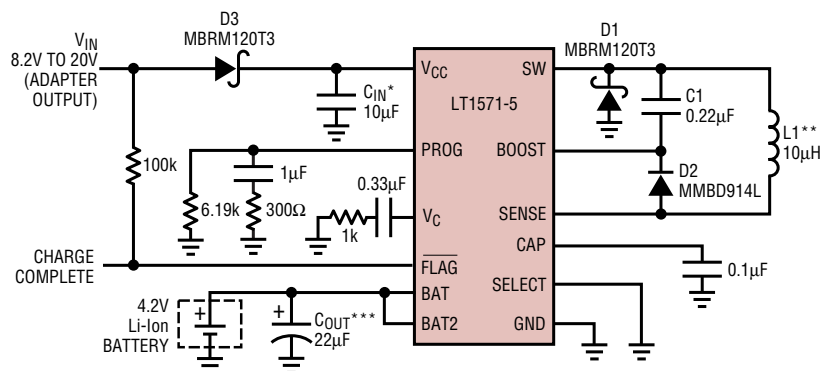

* TOKIN OR MARCON CERAMIC SURFACE MOUNT

** COILTRONICS TP3-100, 10 μ H, 2.2mm HEIGHT (0.8A CHARGING CURRENT)

COILTRONICS TP1 SERIES, 10 μ H, 1.8mm HEIGHT (<0.5A CHARGING CURRENT)

*** PANASONIC EEFCD1B220

1571 F01

Figure 1. Compact Li-Ion Cellular Phone Charger (0.8A)

LT1571 Series

ABSOLUTE MAXIMUM RATINGS (Note 1)

Supply Voltage (V_{CC})	28V	Operating Ambient	
BOOST Pin Voltage with Respect to V_{CC}	20V	Temperature Range (Note 2)	-40°C to 85°C
FLAG Pin Voltage	V_{CC}	Operating Junction	
I_{BAT} (Average)	1.5A	Temperature Range	-40°C to 125°C
Switch Current (Peak)	2A	Lead Temperature (Soldering, 10 sec)	300°C
Storage Temperature Range	-65°C to 150°C		

PACKAGE/ORDER INFORMATION

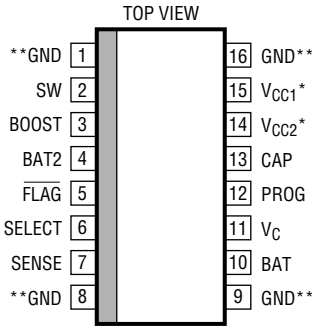
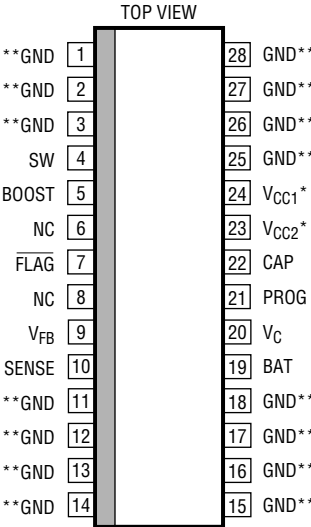
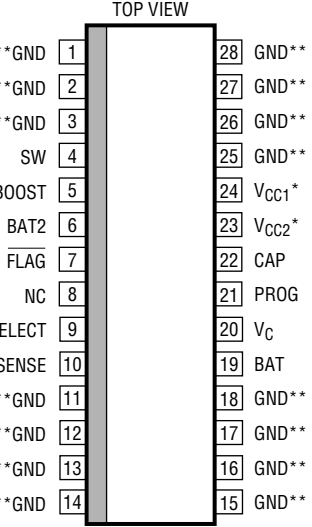
 <p>GN PACKAGE 16-LEAD NARROW PLASTIC SSOP $T_{JMAX} = 125^{\circ}C, \theta_{JA} = 75^{\circ}C/W$</p> <p>* V_{CC1} AND V_{CC2} SHOULD BE CONNECTED TOGETHER CLOSE TO THE PINS ** FOUR CORNER PINS ARE FUSED TO INTERNAL DIE ATTACH PADDLE FOR HEAT SINKING. CONNECT THESE FOUR PINS TO EXPANDED PC LANDS FOR PROPER HEAT SINKING</p>	 <p>GN PACKAGE 28-LEAD NARROW PLASTIC SSOP $T_{JMAX} = 125^{\circ}C, \theta_{JA} = 40^{\circ}C/W$</p> <p>* V_{CC1} AND V_{CC2} SHOULD BE CONNECTED TOGETHER CLOSE TO THE PINS ** ALL GND PINS ARE FUSED TO INTERNAL DIE ATTACH PADDLE FOR HEAT SINKING. CONNECT THESE PINS TO EXPANDED PC LANDS FOR PROPER HEAT SINKING 40°C/W THERMAL RESISTANCE ASSUMES AN INTERNAL GROUND PLANE DOUBLING AS A HEAT SPREADER</p>	 <p>GN PACKAGE 28-LEAD NARROW PLASTIC SSOP $T_{JMAX} = 125^{\circ}C, \theta_{JA} = 40^{\circ}C/W$</p> <p>* V_{CC1} AND V_{CC2} SHOULD BE CONNECTED TOGETHER CLOSE TO THE PINS ** ALL GND PINS ARE FUSED TO INTERNAL DIE ATTACH PADDLE FOR HEAT SINKING. CONNECT THESE PINS TO EXPANDED PC LANDS FOR PROPER HEAT SINKING 40°C/W THERMAL RESISTANCE ASSUMES AN INTERNAL GROUND PLANE DOUBLING AS A HEAT SPREADER</p>
ORDER PART NUMBER	ORDER PART NUMBER	ORDER PART NUMBER
LT1571EGN-5	LT1571EGN-1	LT1571EGN-2

Consult factory for Industrial and Military grade parts.

ELECTRICAL CHARACTERISTICS

The ● denotes specifications which apply over the full operating temperature range, otherwise specifications are $T_A = 25^\circ\text{C}$. $V_{CC} = 16\text{V}$ (LT1571-1, LT1571-2), $V_{CC} = 10\text{V}$ (LT1571-5), $V_{BAT} = 8\text{V}$ (LT1571-1, LT1571-2), $V_{BAT} = 4\text{V}$ (LT1571-5), no load on any outputs unless otherwise noted. (Note 6)

PARAMETER	CONDITIONS		MIN	TYP	MAX	UNITS	
Overall							
Supply Current	$V_{PROG} = 2.7\text{V}$	●		5.2	7	mA	
DC Battery Charging Current, I_{BAT}	$8\text{V} \leq V_{CC} \leq 26\text{V}$, $0\text{V} \leq V_{BAT} \leq 20\text{V}$ (LT1571-1)	●		0.93	1.0	1.07	A
	$R_{PROG} = 4.93\text{k}$	●		0.91		1.09	A
	$R_{PROG} = 4.93\text{k}$, $T_J < 0^\circ\text{C}$	●		1.35	1.5	1.65	A
	$R_{PROG} = 3.28\text{k}$	●		75	100	125	mA
	$R_{PROG} = 49.3\text{k}$, $T_J < 0^\circ\text{C}$	●		70		130	mA
Shutdown							
Auto Shutdown, Reverse Current from Battery (When Adapter in Figure 1 Circuit is Removed)	$V_{BAT} \leq 20\text{V}$, $0^\circ\text{C} \leq T_J \leq 70^\circ\text{C}$ (LT1571-1)			5	15	μA	
Shutdown Threshold at V_C Pin When V_{CC} is Connected			40	80		mV	
Shutdown Supply Current	$V_C \leq 40\text{mV}$			0.15	0.3	mA	
Reference							
Reference Voltage (LT1571-1)	$R_{PROG} = 4.93\text{k}$. Measured at V_{FB} , with VA Supplying I_{PROG} and Switch Off						
	$8\text{V} \leq V_{CC} \leq 26\text{V}$, $0^\circ\text{C} \leq T_J \leq 70^\circ\text{C}$		2.446	2.465	2.480	V	
	$8\text{V} \leq V_{CC} \leq 26\text{V}$, $0^\circ\text{C} \leq T_J \leq 125^\circ\text{C}$		2.441	2.465	2.489	V	
	$8\text{V} \leq V_{CC} \leq 26\text{V}$, $T_J < 0^\circ\text{C}$ (Note 5)		2.430	2.465	2.480	V	
Preset Battery Voltage							
LT1571-2: 8.2V/8.4V LT1571-5: 4.1V/4.2V	$R_{PROG} = 4.93\text{k}$. Measured at BAT2 Pin $T_J = 25^\circ\text{C}$ $8\text{V} \leq V_{CC} \leq 26\text{V}$, $0^\circ\text{C} \leq T_J \leq 125^\circ\text{C}$			0.5		%	
			-1		1	%	
Voltage Setting Resistors Tolerance (R4, R5)	Absolute Value, Not Matching		-40		40	%	
BAT2 Pin Input Current (LT1571-2, LT1571-5)	$V_{BAT2} = V_{PRESET} - 1\text{V}$	●			6	μA	
Charge Completion Flag (Comparator E6)							
Charge Completion Threshold (Note 8)	$R_{PROG} = 4.93\text{k}$		0.14	0.20	0.28	A	
	$R_{PROG} = 4.93\text{k}$, $R_{CAP} = 65.6\text{k}$		0.05	0.085	0.13	A	
Threshold on CAP Pin	Low-to-High Threshold			4	4.5	V	
	High-to-Low Threshold		0.6			V	
$\overline{\text{FLAG}}$ (Open Collector) Output Low	$V_{CAP} = 4.5\text{V}$, $I_{FLAG} \leq 1\text{mA}$	●			0.3	V	
$\overline{\text{FLAG}}$ Pin Leakage Current	$V_{CAP} = 0.6\text{V}$, $V_{CC} = 26\text{V}$	●			3	μA	
Voltage Amplifier VA							
Transconductance	Output Current from $100\mu\text{A}$ to $500\mu\text{A}$		0.3	0.6	2.5	mho	
Output Source Current	$V_{PROG} = V_{REF}$, $V_{FB} = V_{REF} + 10\text{mV}$		1.3			mA	
V_{FB} Input Bias Current (LT1571-1)	At 0.75mA Output Current	●		± 3	± 15	nA	
Overall							
Minimum Input Operating Voltage	Undervoltage Lockout	●	6.2	7	7.8	V	
Boost Pin Current	$V_{CC} - V_{BOOST} \leq 20\text{V}$	●		0.10	20	μA	
	$20\text{V} < V_{CC} - V_{BOOST} \leq 26\text{V}$	●		0.25	30	μA	
	$2\text{V} \leq V_{BOOST} - V_{CC} \leq 8\text{V}$ (Switch ON)	●		6	11	mA	
	$8\text{V} < V_{BOOST} - V_{CC} \leq 20\text{V}$ (Switch ON) (LT1571-1)	●		8	14	mA	

ELECTRICAL CHARACTERISTICS

The ● denotes specifications which apply over the full operating temperature range, otherwise specifications are $T_A = 25^\circ\text{C}$. $V_{CC} = 16\text{V}$ (LT1571-1, LT1571-2), $V_{CC} = 10\text{V}$ (LT1571-5), $V_{BAT} = 8\text{V}$ (LT1571-1, LT1571-2), $V_{BAT} = 4\text{V}$ (LT1571-5), no load on any outputs unless otherwise noted. (Note 6)

PARAMETER	CONDITIONS		MIN	TYP	MAX	UNITS
Switch						
Switch ON Resistance	$I_{SW} = 1.5\text{A}$, $V_{BOOST} - V_{SW} \geq 2\text{V}$ $I_{SW} = 1\text{A}$, $V_{BOOST} - V_{SW} < 2\text{V}$ (Unboosted)	● ●		0.3	0.5 2.0	Ω Ω
$\Delta I_{BOOST}/\Delta I_{SW}$ During Switch ON	$V_{BOOST} = (V_{CC} + 8\text{V})$, $I_{SW} \leq 1\text{A}$			20	35	mA/A
Switch OFF Leakage Current	$V_{SW} = 0\text{V}$, $V_{CC} \leq 20\text{V}$ $V_{SW} = 0\text{V}$, $20\text{V} < V_{CC} \leq 26\text{V}$			2 4	100 200	μA μA
Maximum V_{BAT} with Switch ON		●			$V_{CC} - 2$	V
Minimum I_{PROG} for Switch ON			1	4	27	μA
Minimum I_{PROG} for Switch OFF		●	1	2.4		mA
Current Sense Amplifier Inputs (SENSE, BAT)						
Sense Resistance (R_{S1})				0.08	0.12	Ω
Total Resistance from SENSE to BAT (Note 3)				0.2	0.25	Ω
BAT Bias Current (Note 4)	$V_C < 0.3\text{V}$ $V_C > 0.6\text{V}$ $V_C < 40\text{mV}$	●		-200 700	-375 1300 5	μA μA μA
Oscillator						
Switching Frequency	LT1571-1, LT1571-2 LT1571-5		180 440	200 500	220 550	kHz kHz
Switching Frequency Tolerance	All Conditions of V_{CC} , Temperature, LT1571-1, LT1571-2 LT1571-1, LT1571-2, $T_J < 0^\circ\text{C}$ LT1571-5 LT1571-5, $T_J < 0^\circ\text{C}$	● ● ●	170 160 425 400	200 500	230 230 575 575	kHz kHz kHz kHz
Maximum Duty Cycle	LT1571-1, LT1571-2 LT1571-1, LT1571-2, $T_A = 25^\circ\text{C}$ (Note 7) LT1571-5	● ● ●	87 90 77	93		% % %
Current Amplifier (CA2)						
Transconductance	$V_C = 1\text{V}$, $I_{VC} = \pm 1\mu\text{A}$		125	210	550	μmho
Maximum V_C for Switch OFF		●			0.6	V
I_{VC} Current (Out of Pin)	$V_C \geq 0.6\text{V}$ $0.2\text{V} < V_C < 0.45\text{V}$ $V_C < 40\text{mV}$ (Shutdown)				100 3 300	μA mA μA

Note 1: Absolute Maximum Ratings are those values beyond which the life of a device may be impaired.

Note 2: The LT1571 is guaranteed to meet performance specifications from 0°C to 70°C . Specifications over the -40°C to 85°C operating temperature range are assured by design, characterization and correlation with statistical process controls.

Note 3: Sense resistor R_{S1} and package bond wires.

Note 4: Current ($\approx 700\mu\text{A}$) flows into the pins during normal operation and also when an external shutdown signal on the V_C pin is greater than 0.3V . Current decreases to $\approx 200\mu\text{A}$ and flows out of the pins when external shutdown holds the V_C pin below 0.3V but above shutdown threshold. Current drops to near zero when input voltage collapses. See External Shutdown in Applications Information section.

Note 5: A linear interpolation can be used for reference voltage specification between 0°C and -40°C .

Note 6: Maximum allowable ambient temperature may be limited by power dissipation. Parts may not necessarily be operated simultaneously at maximum power dissipation and maximum ambient temperature. Temperature rise calculations must be done as shown in the Applications Information section to ensure that maximum junction temperature does not exceed the 125°C limit. With high power dissipation, maximum ambient temperature may be less than 70°C .

Note 7: 91% maximum duty cycle is guaranteed by design if V_{BAT} or V_X (see Figure 8 in Applications Information) is kept between 3V and 5V .

Note 8: See "Lithium-Ion Charging Completion" in the Applications Information section.

TYPICAL PERFORMANCE CHARACTERISTICS

Efficiency of Figure 4 Circuit

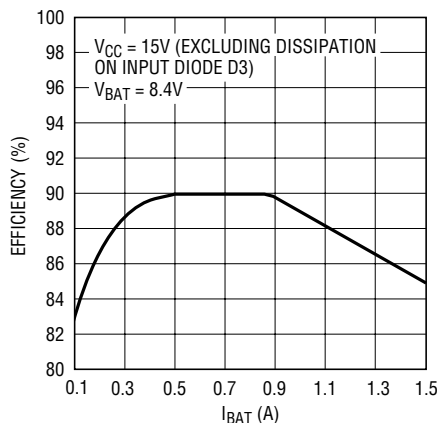

1571 G01

Reference Voltage vs Junction Temperature

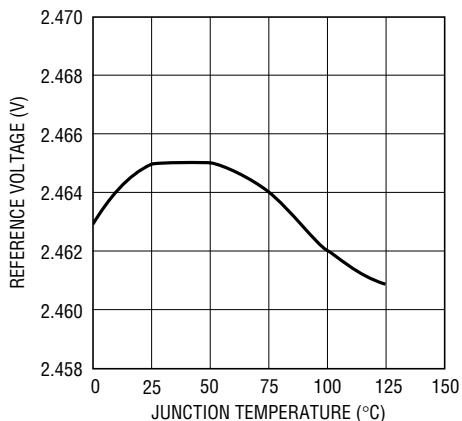

1571 G02

Boost Current vs Switch Current

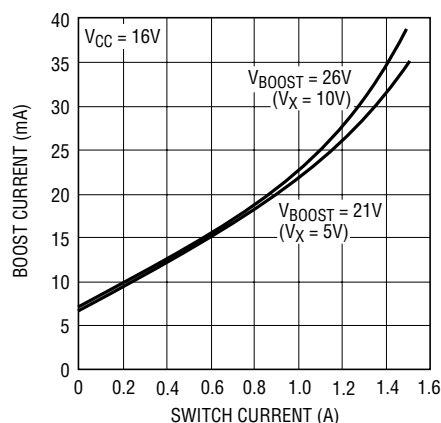

1571 G03

Switching Frequency vs Temperature

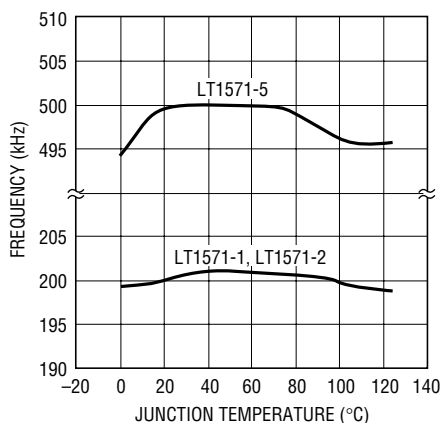

1571 G04

VREF Line Regulation

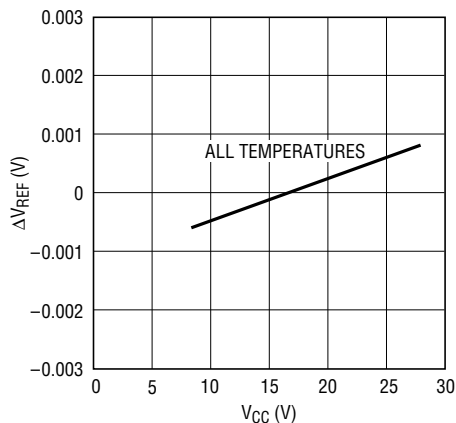

1571 G05

ΔVOVP vs IVA (Voltage Amplifier)

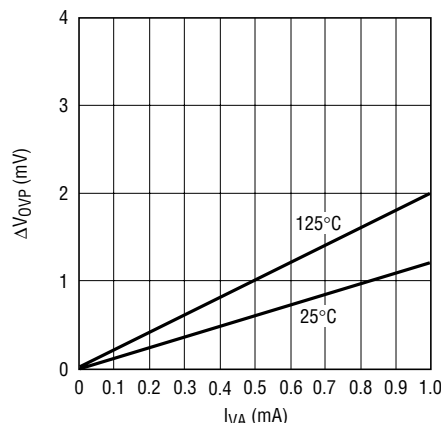

1571 G06

Maximum Duty Cycle

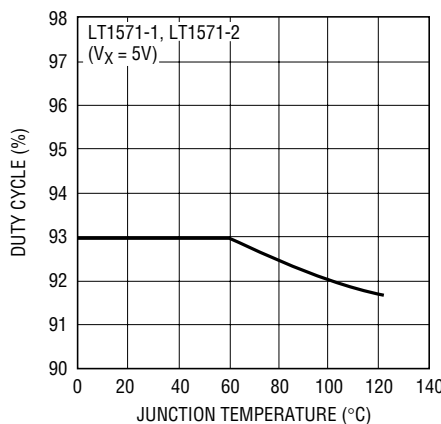

1571 G09

VC Pin Characteristic

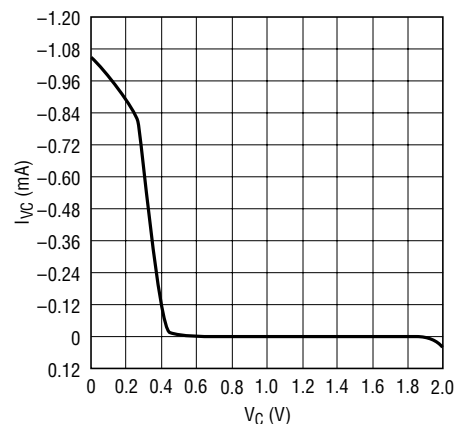

1571 G08

PROG Pin Characteristic

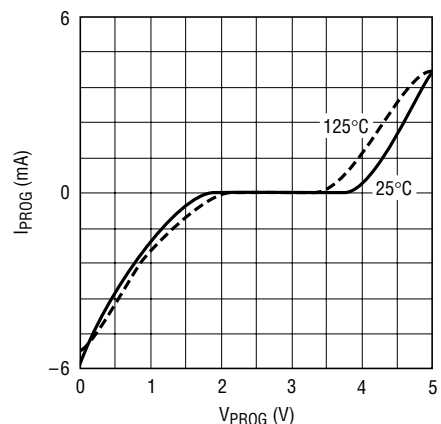

1571 G09

PIN FUNCTIONS

GND: Ground Pin.

SW: NPN Power Switch Emitter. The Schottky catch diode must be placed with very short lead length in close proximity to SW pin and GND.

V_{CC1}, V_{CC2}: Input Supply. For good bypass, a low ESR capacitor of 10 μ F or higher is required, with the lead length kept to a minimum. V_{CC} should be between 8V and 26V and at least 2V higher than V_{BAT} for V_{BAT} less than 10V, and 2.5V higher than V_{BAT} for V_{BAT} greater than 10V. Under-voltage lockout starts and switching stops when V_{CC} goes below 7V (typical). Note that there is an internal parasitic diode from SW pin to V_{CC} pin. Do not force V_{CC} below SW by more than 0.7V with battery present. All V_{CC} pins should be shorted together close to the pins.

BOOST: This pin is used to bootstrap and drive the NPN switch to a low on-voltage for low power dissipation. V_{BOOST} = V_{CC} + V_{BAT} when switch is on. For less power dissipation use V_{BOOST} = 3V to 6V (see Applications Information).

SENSE: Current Amplifier CA1 Input. Sensing can be at either terminal of the battery. Note that current sense resistor R_{S1} (0.08 Ω) is between SENSE and BAT pins.

BAT: Current Amplifier CA1 Input.

BAT2 (LT1571-2, LT1571-5): This pin is used to connect the battery to the internal preset voltage setting resistor. An internal switch disconnects the internal divider from the battery when the device is in shutdown or when input power is disconnected. This disconnect function eliminates current drain due to the resistor divider. This pin should be connected to the positive node of the battery if the internal preset divider is used. Otherwise this pin should be grounded. Maximum voltage on this pin is 20V.

PROG: This pin is for programming the charge current and for system loop compensation. Charge current is regulated to 2000 \times the current drawn from the PROG pin. During normal operation, V_{PROG} stays close to 2.465V. If it is shorted to GND, switching will stop. When

a microprocessor-controlled DAC is used to program charge current, it must be capable of sinking current at a compliance up to 2.465V.

V_C: This is the inner loop control signal of the current mode PWM. Switching starts at 0.9V. In normal operation, a higher V_C corresponds to a higher charge current. A capacitor of at least 0.1 μ F to GND filters out noise and controls the rate of soft-start. To shut down switching, pull this pin below 0.6V. Typical current out of this pin is 60 μ A. When V_C is pulled below 40mV, LT1571 supply current drops to typical 150 μ A.

SELECT (LT1571-2, LT1571-5): This pin is used to select the preset battery voltage. For the LT1571-2, leave this pin open for 8.2V and ground it for 8.4V. For the LT1571-5, leave this pin open for 4.1V and ground it for 4.2V. For other battery voltages, use the adjustable LT1571-1.

V_{FB} (LT1571-1): This is the input to the amplifier VA (see Block Diagram) with a threshold of 2.465V. Typical input current is about 3nA. When charging batteries, VA monitors the battery voltage and reduces charging current when battery voltage reaches the preset value. If it is not used (constant-current only mode), the V_{FB} pin should be grounded.

CAP: A 0.1 μ F capacitor from CAP to ground is needed to filter the sampled charge current signal. This filtered signal is used to set the $\overline{\text{FLAG}}$ pin when the charge current drops to 20% of the programmed maximum charge current. This threshold level can be set as low as 7.5% of the programmed maximum charge current by adding a resistor on the CAP pin.

FLAG: This pin is an open-collector output that is used to indicate end of charge. The $\overline{\text{FLAG}}$ pin is driven low when the charge current drops below a certain percentage of the programmed charge current as explained in the CAP pin function. A pull-up resistor is required if this function is used. This pin is capable of sinking at least 1mA. Maximum voltage on this pin is V_{CC}.

BLOCK DIAGRAM

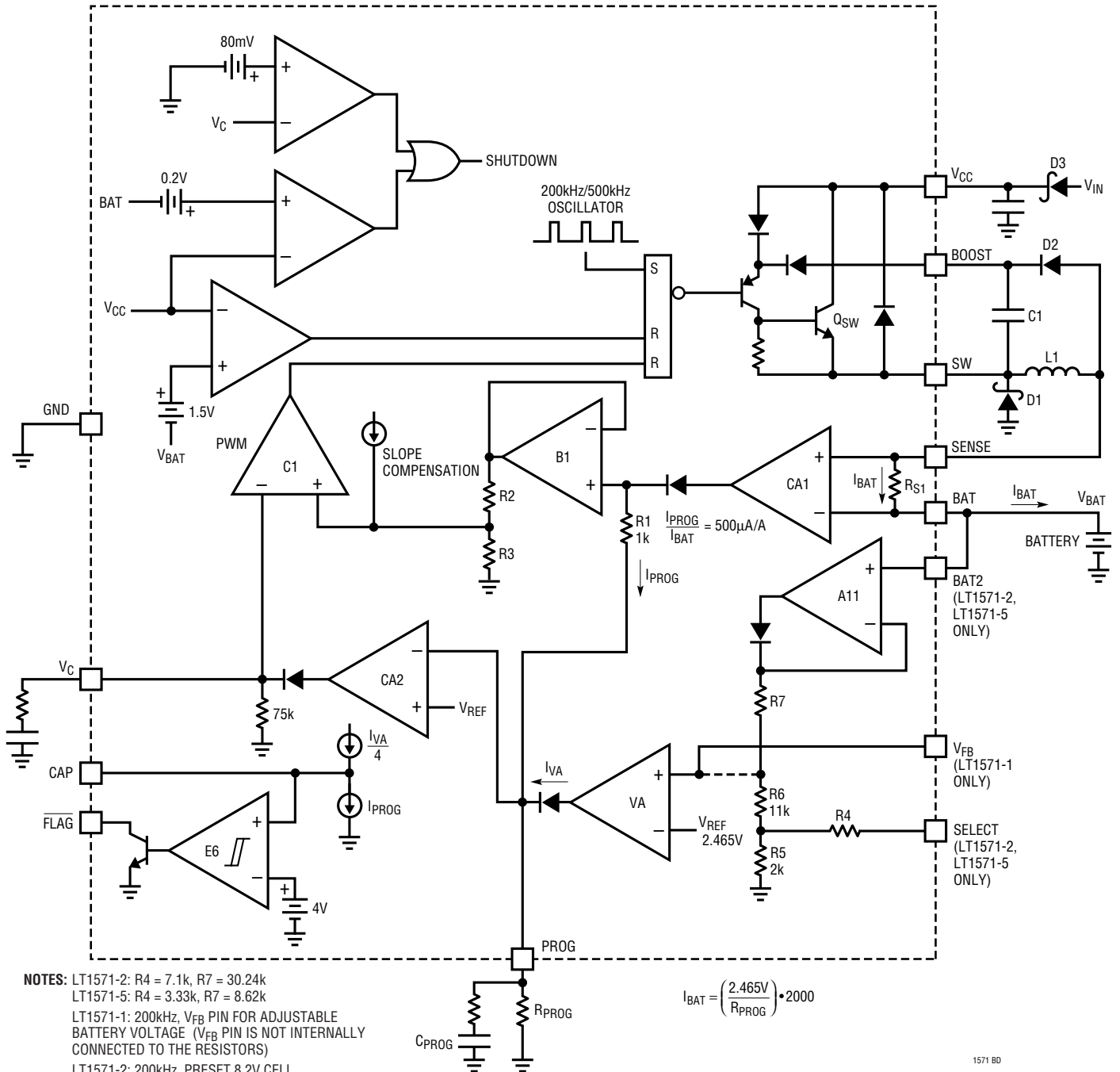

1571 BD

OPERATION

The LT1571 is a current mode PWM step-down (buck) charger. The battery charge current is programmed by a resistor R_{PROG} (or a DAC output current) at the PROG pin (see Block Diagram). Amplifier CA1 converts the charge current through R_{S1} to a much lower current I_{PROG} ($500\mu\text{A}/\text{A}$) fed into the PROG pin. Amplifier CA2 compares the output of CA1 with the programmed current and drives the PWM loop to force them to be equal. High DC accuracy is achieved with averaging capacitor C_{PROG} . Note that I_{PROG} has both AC and DC components. I_{PROG} goes through R1 and generates a ramp signal that is fed to the PWM control comparator C1 through buffer B1 and level shift resistors R2 and R3, forming the current mode inner loop. The BOOST pin drives the NPN switch (Q_{SW}) into saturation and reduces power loss. For batteries like lithium-ion that

require both constant-current and constant-voltage charging, the 0.5%, 2.465V reference and the amplifier VA reduce the charge current when battery voltage reaches the preset level. For NiMH and NiCd, VA can be used for overvoltage protection. When input voltage is removed, the V_{CC} pin drops to 0.7V below the battery voltage forcing the charger into a low-battery drain ($5\mu\text{A}$ typical) sleep mode. To shut down the charger, simply pull the V_{C} pin low with a transistor.

Comparator E6 monitors the charge level and signals through the FLAG pin when charging is in voltage mode and the charge current has reduced to 20% or less. This charge complete signal can be used to start a timer for charging termination.

APPLICATIONS INFORMATION

Input and Output Capacitors

In the charger circuits in Figures 1 and 2, the input capacitor C_{IN} is assumed to absorb all input switching ripple current in the converter, so it must have adequate ripple current rating. Worst-case RMS ripple current will be equal to one half of the output charge current. Actual capacitance value is not critical. Solid tantalum capacitors such as the AVX TPS and Sprague 593D series have high ripple current rating in a relatively small surface mount package, but *caution must be used when tantalum capacitors are used for input bypass*. High input surge currents are possible when the adapter is hot-plugged to the charger and solid tantalum capacitors have a known failure mechanism when subjected to very high turn-on surge currents. Selecting a high voltage rating on the capacitor will minimize problems. Consult with the manufacturer before use. Alternatives include new high capacity ceramic capacitors from Tokin or United Chemi-Con/MARCON, et al. OS-CON can also be used.

The output capacitor C_{OUT} is also assumed to absorb output switching ripple current. The general formula for capacitor ripple current is:

$$I_{\text{RMS}} = \frac{0.29(V_{\text{BAT}}) \left(1 - \frac{V_{\text{BAT}}}{V_{\text{CC}}}\right)}{(L1)(f)}$$

For example, with $V_{\text{CC}} = 16\text{V}$, $V_{\text{BAT}} = 8.4\text{V}$, $L1 = 33\mu\text{H}$ and $f = 200\text{kHz}$, $I_{\text{RMS}} = 0.18\text{A}$.

EMI considerations usually make it desirable to minimize ripple current in the battery leads. Beads or inductors can be added to increase battery impedance at the 200kHz switching frequency. Switching ripple current splits between the battery and the output capacitor depending on the ESR of the output capacitor and the battery impedance. If the ESR of C_{OUT} is 0.2Ω and the battery impedance is raised to 4Ω with a bead of inductor, only 5% of the ripple current will flow into the battery.

Soft-Start

The LT1571 is soft-started by the $0.33\mu\text{F}$ capacitor on V_{C} pin. On start-up, the V_{C} pin voltage will rise quickly to 0.5V, then ramp at a rate set by the internal $45\mu\text{A}$ pull-up current and the external capacitor. Charge current starts ramping up when the V_{C} pin voltage reaches 0.9V and full current

APPLICATIONS INFORMATION

is achieved with V_C at 1.1V. With a 0.33 μ F capacitor, the time to reach full charge current is about 9ms and it is assumed that input voltage to the charger will reach full value in less than 3ms. Capacitance can be increased up to 1 μ F if longer input start-up times are needed.

In any switching regulator, conventional time-based soft starting can be defeated if the input voltage rises much slower than the time-out period. This happens because the switching regulators in the battery charger and the computer power supply are typically supplying a fixed amount of power to the load. If the input voltage comes up slowly compared to the soft-start time, the regulators will try to deliver full power to the load when the input voltage is still well below its final value. If the adapter is current limited, it cannot deliver full power at reduced output voltages and the possibility exists for a quasi “latch” state where the adapter output stays in a current limited state at reduced output voltage. For instance, if maximum charger plus computer load power is 20W, a 24V adapter might be current limited at 1A. If adapter voltage is less than (20W/1A = 20V) when full power is drawn, the adapter voltage will be pulled down by the constant 20W load until it reaches a lower stable state where the switching regulators can no longer supply full load. This situation can be prevented by utilizing *undervoltage lockout*, set higher than the minimum adapter voltage where full power can be achieved.

A fixed undervoltage lockout of 7V is built into the LT1571. A higher lockout voltage can be implemented with a Zener diode D2 (see Figure 2).

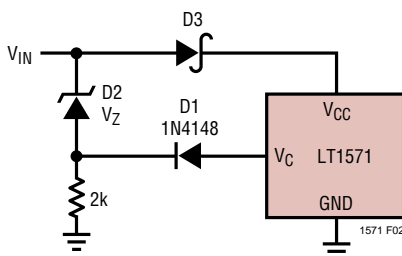

Figure 2. Undervoltage Lockout

The lockout voltage will be $V_{IN} = V_Z + 1V$.

For example, for a 24V adapter to start charging at 22V_{IN}, choose $V_Z = 21V$. When V_{IN} is less than 22V, D1 keeps V_C low and charger off.

Charge Current Programming

The basic formula for charge current is (see Block Diagram):

$$I_{BAT} = (I_{PROG})(2000) = \left(\frac{2.465V}{R_{PROG}} \right) (2000)$$

where R_{PROG} is the total resistance from PROG pin to ground.

For example, 1A charge current is needed.

$$R_{PROG} = \frac{(2.465V)(2000)}{1A} = 4.93k$$

Charge current can also be programmed by pulse width modulating I_{PROG} with a switch Q1 to R_{PROG} at a frequency higher than a few kHz (Figure 3). Charge current will be proportional to the duty cycle of Q1 with full current at 100% duty cycle.

When a microprocessor DAC output is used to control charge current, it must be capable of sinking current at a compliance up to 2.5V if connected directly to the PROG pin.

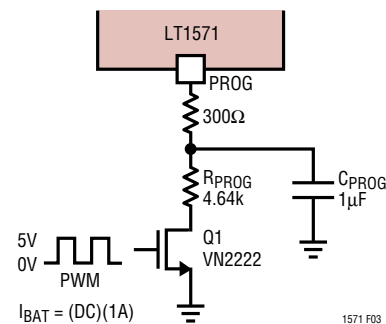

Figure 3. PWM Current Programming

APPLICATIONS INFORMATION

Lithium-Ion Charging

The circuit in Figure 4 uses the 28-pin LT1571-2 to charge lithium-ion batteries at a constant 1A until the battery voltage reaches 8.4V preset battery voltage. The charger will then automatically go into a constant-voltage mode with current decreasing to near zero over time as the battery reaches full charge.

Lithium-Ion Charge Completion

Some battery manufacturers recommend termination of constant-voltage float mode after charge current has dropped below a specified level (typically around 10% to 20% of the full current) and a further time-out period of 30 minutes to 90 minutes has elapsed. Check with manufacturer for details. The LT1571 provides a signal at the $\overline{\text{FLAG}}$ pin when the charger is in voltage mode and charge current has reduced to approximately 20% of full current. Note that full current is $(2.465\text{V} \times 2000) / R_{\text{PROG}}$. Comparator E6 in the Block Diagram compares the charge current sample I_{PROG} to the output current I_{VA} voltage amplifier VA. When the charge current drops to 20% of full current, I_{PROG} will be equal to 0.25 I_{VA} and the open-collector output $V_{\overline{\text{FLAG}}}$ will go low. This signal can be used to start an external timer or to terminate the charge. When this feature is used, a capacitor of at least 0.1 μF is required at

CAP pin to filter out the switching noise and a pull-up resistor is also needed at $\overline{\text{FLAG}}$ pin.

Charge Termination Flag Threshold Setting

The charge termination flag threshold can be reduced from the default 20% level to as low as 7.5% of the programmed full charge current. This is done by adding a resistor R_{CAP} from the CAP pin to ground (see Figure 5). The formula for selecting the R_{CAP} resistor is:

$$\text{Threshold} = 0.20 - (1.331) \frac{R_{\text{PROG}}}{R_{\text{CAP}}}$$

or

$$R_{\text{CAP}} = \frac{(1.331)R_{\text{PROG}}}{0.20 - \text{Threshold}}$$

R_{PROG} is the charge current setting resistor.

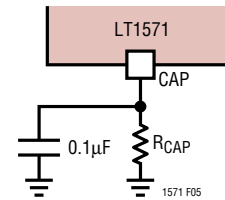
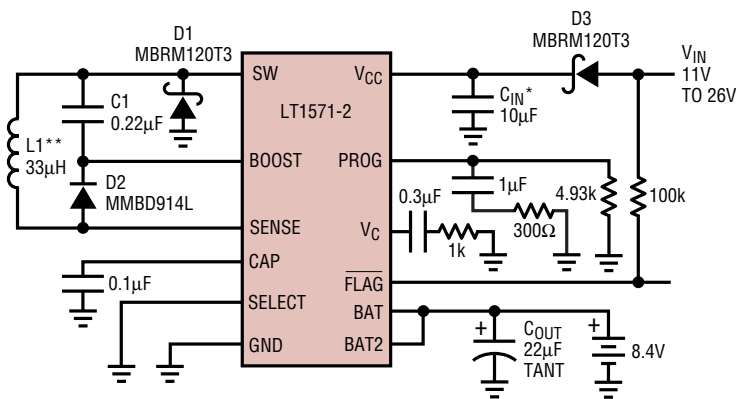

Figure 5. Reducing Charge Termination Threshold



NOTE: COMPLETE LITHIUM-ION CHARGER
 * TOKIN OR MARCON CERAMIC SURFACE MOUNT
 ** COILTRONICS CTX33-2

1571 F04

Figure 4. 200kHz Charging Lithium Batteries (Efficiency at 1A > 87%)

APPLICATIONS INFORMATION

For example, if 10% threshold is needed for the 1A charger (see Figure 4), then with $R_{\text{PROG}} = 4.93\text{k}$:

$$R_{\text{CAP}} = \frac{1.331 \cdot 4.93\text{k}}{0.20 - 0.10} = 65.6\text{k}$$

Because of low level errors, as the threshold level is reduced, the accuracy is also reduced. It is not recommended to program a level less than 7.5%.

Preset Battery Voltage Settings

The LT1571-2 operates at 200kHz and is preset for 8.2V battery voltage with SELECT pin floating and 8.4V with SELECT pin grounded.

The LT1571-5 operates at 500kHz and is preset for 4.1V battery voltage with SELECT pin floating and 4.2V with SELECT pin grounded.

BAT2 pin is for Kelvin sensing the battery voltage and should be connected to the battery.

Other Battery Voltage Settings

For battery voltages other than the preset voltages, the LT1571-1 should be used. It operates at 200kHz and the battery voltage is programmed with R3 and R4 divider at V_{FB} pin (Figure 6).

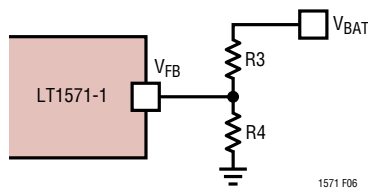

Figure 6. Programming Other Battery Voltages

Current through the R3/R4 divider is set at a compromise value of $25\mu\text{A}$ to minimize battery drain when the charger is off. The V_{FB} pin input current of 3nA contributes very little output voltage error and can be neglected.

With divider current set at $25\mu\text{A}$, $R4 = 2.465/25\mu\text{A} = 100\text{k}$ and,

$$R3 = \frac{(R4)(V_{\text{BAT}} - 2.465)}{2.465}$$

Lithium-ion batteries typically require float voltage accuracy of 1% to 2%. Accuracy of the LT1571-1 V_{FB} voltage is $\pm 0.5\%$ at 25°C and $\pm 1\%$ over full temperature. This leads to the possibility that very accurate (0.1%) resistors might be needed for R3 and R4. Actually, the temperature of the LT1571-1 rarely exceeds 50°C in float mode because charge currents have tapered off to a low level, so 0.25% resistors normally provide the required level of overall accuracy.

External Shutdown

The LT1571 can be externally shut down by pulling the V_{C} pin low with an open-drain N-FET, such as 2N7002. The V_{C} pin should be pulled below 0.6V to stop switching. When V_{C} is pulled below 40mV, LT1571 supply current drops to typical $150\mu\text{A}$.

Removing input power to the charger puts the LT1571 into a sleep mode and draws only $5\mu\text{A}$ from the battery.

Nickel-Cadmium and Nickel-Metal-Hydride Charging

The circuit in Figure 7 uses the LT1571-1 to charge NiCd or NiMH batteries up to 20V with charge currents of 0.5A when Q1 is on and 50mA when Q1 is off.

For a 2-level charger, R1 and R2 are found from:

$$I_{\text{BAT}} = \frac{(2000)(2.465)}{R_{\text{PROG}}}$$

$$R1 = \frac{(2.465)(2000)}{I_{\text{LOW}}} \quad R2 = \frac{(2.465)(2000)}{I_{\text{HI}} - I_{\text{LOW}}}$$

All battery chargers with fast-charge rates require some means to detect full charge in the battery and terminate the high charge current. NiCd batteries are typically charged at high current until the battery temperature begins to increase or until the battery voltage reaches a peak and begins to decrease ($-dV/dt$). This is an indication of near full charge. The charge current is then reduced to a much

APPLICATIONS INFORMATION

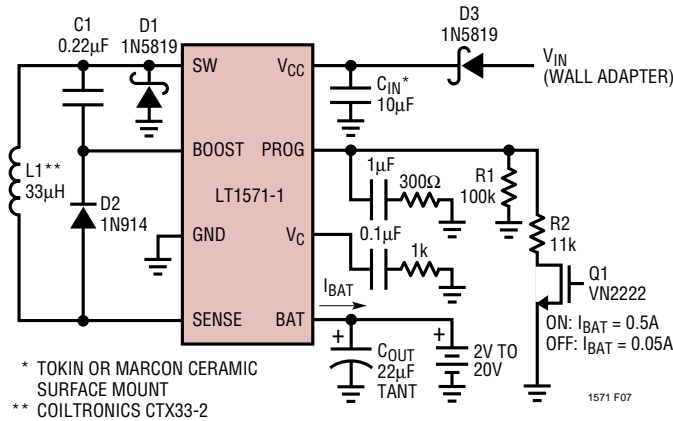

Figure 7. Charging NiMH or NiCd Batteries with Constant Current (Efficiency at 0.5A ≈ 90%)

lower value and maintained as a constant trickle charge. An intermediate “top off” current may also be used for a fixed time period to reduce total charge time.

NiMH batteries are similar in chemistry to NiCd but have two differences related to charging. First, the inflection characteristic in battery voltage as full charge is approached is not nearly as pronounced. This makes it more difficult to use $-dV/dt$ as an indicator of full charge, and an increase in temperature is more often used with a temperature sensor located in the battery pack. Secondly, constant trickle charge may not be recommended. Instead, a moderate level of current is used on a pulse basis ($\approx 1\%$ to 5% duty cycle) with the time-averaged value substituting for a constant low trickle.

Thermal Calculations

If the LT1571 is used for charge currents above 0.4A, a thermal calculation should be done to ensure that junction temperature will not exceed 125°C . Power dissipation in the IC is caused by bias and driver current, switch resistance, switch transition losses and the current sense resistor. The following equations show that maximum practical charge current for the 16-pin SSOP package (75°C/W thermal resistance) is about 1.2A for an 8.4V battery and 1.4A for a 4.2V battery. This assumes a 60°C maximum ambient temperature. The 28-pin SSOP, with a thermal resistance of 40°C/W , can provide a full 1.5A charge current in many situations.

$$P_{\text{BIAS}} = (3.5\text{mA})(V_{\text{IN}}) + 1.5\text{mA}(V_{\text{BAT}}) + \frac{(V_{\text{BAT}})^2}{V_{\text{IN}}} [7.5\text{mA} + (0.012)(I_{\text{BAT}})]$$

$$P_{\text{DRIVER}} = \frac{(I_{\text{BAT}})(V_{\text{BAT}})^2 \left(1 + \frac{V_{\text{BAT}}}{30}\right)}{55(V_{\text{IN}})}$$

$$P_{\text{SW}} = \frac{(I_{\text{BAT}})^2 (R_{\text{SW}})(V_{\text{BAT}})}{V_{\text{IN}}} + (t_{\text{OL}})(V_{\text{IN}})(I_{\text{BAT}})(f)$$

$$P_{\text{SENSE}} = (0.18\Omega)(I_{\text{BAT}})^2$$

R_{SW} = Switch ON resistance $\approx 0.35\Omega$
 t_{OL} = Effective switch overlap time $\approx 10\text{ns}$
 f = 200kHz (500kHz for LT1571-5)

Example: $V_{\text{IN}} = 15\text{V}$, $V_{\text{BAT}} = 8.4\text{V}$, $I_{\text{BAT}} = 1.2\text{A}$;

$$P_{\text{BIAS}} = (3.5\text{mA})(V_{\text{IN}}) + 1.5\text{mA}(V_{\text{BAT}}) + \frac{(V_{\text{BAT}})^2}{V_{\text{IN}}} [7.5\text{mA} + (0.012)(I_{\text{BAT}})]$$

$$P_{\text{DRIVER}} = \frac{(I_{\text{BAT}})(V_{\text{BAT}})^2 \left(1 + \frac{V_{\text{BAT}}}{30}\right)}{55(V_{\text{IN}})}$$

$$P_{\text{SW}} = \frac{(I_{\text{BAT}})^2 (R_{\text{SW}})(V_{\text{BAT}})}{V_{\text{IN}}} + (t_{\text{OL}})(V_{\text{IN}})(I_{\text{BAT}})(f)$$

$$P_{\text{SENSE}} = (0.18\Omega)(I_{\text{BAT}})^2$$

Total power in the IC is:
 $0.17 + 0.13 + 0.32 + 0.26 = 0.88\text{W}$

Temperature rise will be $(0.88\text{W})(40^{\circ}\text{C/W}) = 35^{\circ}\text{C}$. This assumes that the LT1571 is properly heat sunk by connecting all fused ground pins to the expanded traces and that the PC board has a backside or internal plane for heat spreading.

The P_{DRIVER} term can be reduced by connecting the boost diode D2 to a lower system voltage (lower than V_{BAT})

APPLICATIONS INFORMATION

instead of V_{BAT} (see Figure 8). The optimum boost voltage (V_X) is from 3V to 6V.

Then,

$$P_{DRIVER} = \frac{(I_{BAT})(V_{BAT})(V_X) \left(1 + \frac{V_X}{30}\right)}{55(V_{IN})}$$

For example, $V_X = 3.3V$,

$$P_{DRIVER} = \frac{(1.2A)(8.4V)(3.3V) \left(1 + \frac{3.3V}{30}\right)}{55(15V)} = 0.045W$$

The average I_{VX} required is:

$$\frac{P_{DRIVER}}{V_X} = \frac{0.045W}{3.3V} = 14mA$$

Total board area becomes an important factor when the area of the board drops below about 20 square inches. The graph in Figure 9 shows thermal resistance vs board area for 2-layer and 4-layer boards. Note that 4-layer boards have significantly lower thermal resistance, but both types show a rapid increase for reduced board areas. Figure 10 shows actual measured lead temperature for chargers operating at full current. Battery voltage and input voltage will affect device power dissipation, so the data sheet power calculations must be used to extrapolate these readings to other situations.

Vias should be used to connect board layers together. Planes under the charger area can be cut away from the rest of the board and connected with vias to form both a low thermal resistance system and to act as a ground plane for reduced EMI.

Higher Duty Cycle

Maximum duty cycle for the LT1571-1/LT1571-2 is typically 90% but this may be too low for some applications. For example, if an 18V $\pm 3\%$ adapter is used to charge ten NiMH cells, the charger must put out approximately 15V. A total of 1.6V is lost in the input diode, switch resistance, inductor resistance and parasitics so the required duty

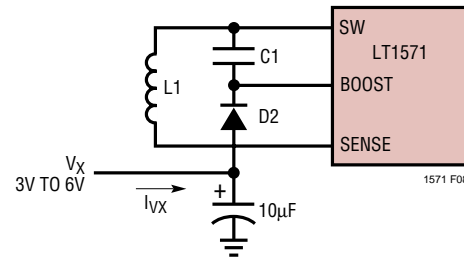

Figure 8. Lower V_{BOOST}

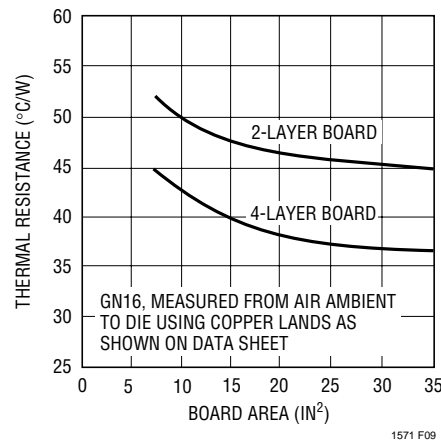

Figure 9. LT1571 Thermal Resistance

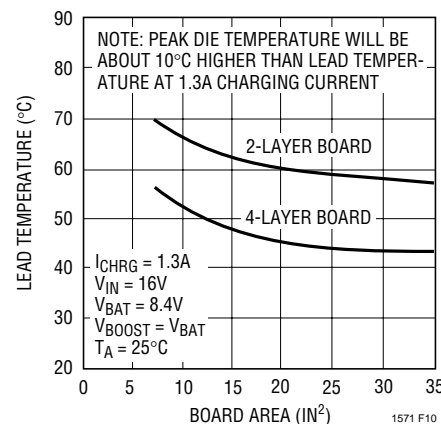

Figure 10. LT1571 Lead Temperature

cycle is $15/16.4 = 91.4\%$. The duty cycle can be extended to 93% by restricting boost voltage to 5V instead of using V_{BAT} as is normally done. This lower boost voltage V_X (see Figure 8) also reduces power dissipation in the LT1571.

APPLICATIONS INFORMATION

Lower Dropout Voltage

For even lower dropout and/or reducing heat on the board, the input diode D3 can be replaced with a FET (see Figure 11). Connect a P-channel FET in place of the input diode with its gate connected to the battery (SENSE pin) causing the FET to turn off when the input voltage goes low. The problem is that the gate must be pumped low so that the FET is fully turned on even when the input is only a volt or two above the battery voltage. Also there is a turn-off speed issue. The FET should turn off instantly when the input is dead shorted to avoid large current surges from the battery back through the charger into the FET. Gate capacitance slows turn off, so a small P-FET (Q2) discharges the gate capacitance quickly in the event of an input short. The body diode of Q2 creates the necessary pumping action to keep the gate of Q1 low during normal operation.

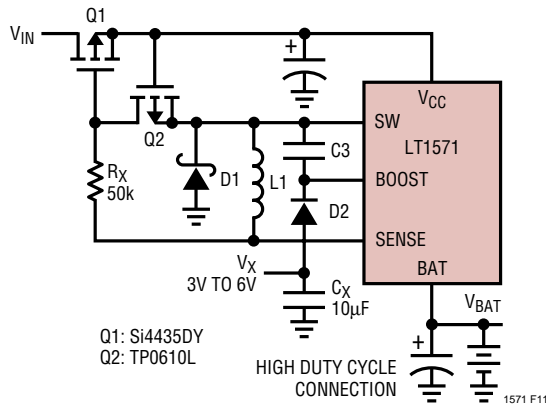

Figure 11. Replacing the Input Diode

Layout Considerations

Switch rise and fall times are under 10ns for maximum efficiency. To minimize radiation, the catch diode, SW pin and input bypass capacitor leads should be kept as short as possible. A ground plane should be used under the switching circuitry to prevent interplane coupling and to act as a thermal spreading path. All ground pins should be connected to expand traces for low thermal resistance. The fast-switching high current ground path including the switch, catch diode and input capacitor should be kept very short. Catch diode and input capacitor should be close to the chip and terminated to the same point. This path contains nanosecond rise and fall times with several amps of current. The other paths contain only DC and /or 200kHz or 500kHz triwave and are less critical. Figure 12 indicates the high speed, high current switching path. Figure 13 shows critical path layout.

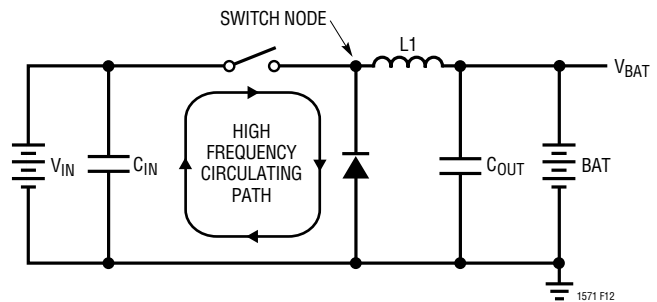

Figure 12. High Speed Switching Path

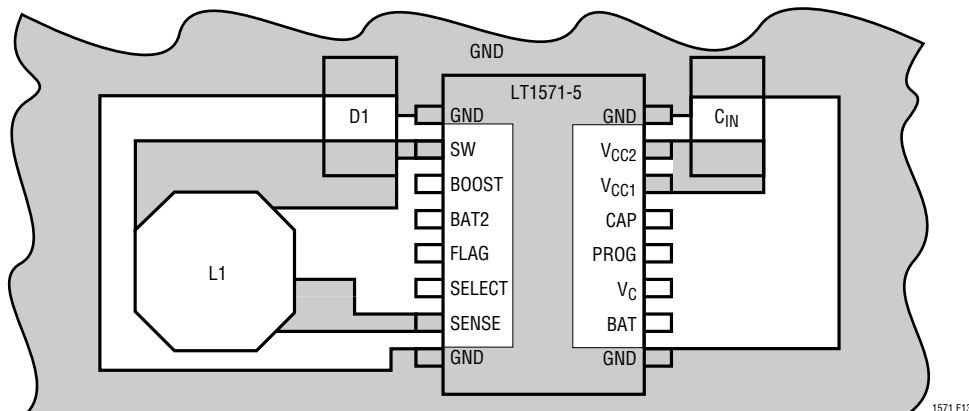
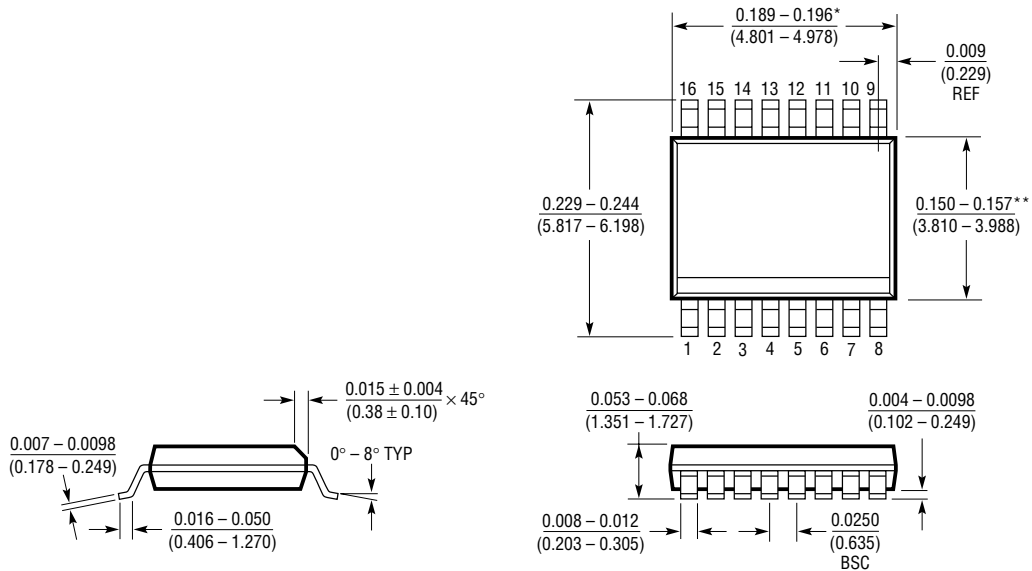

Figure 13. Critical Electrical and Thermal Path Layer for LT1571-5

PACKAGE DESCRIPTION

Dimensions in inches (millimeters) unless otherwise noted.

**GN Package
16-Lead Plastic SSOP (Narrow 0.150)**
(LTC DWG # 05-08-1641)



* DIMENSION DOES NOT INCLUDE MOLD FLASH. MOLD FLASH SHALL NOT EXCEED 0.006" (0.152mm) PER SIDE
 ** DIMENSION DOES NOT INCLUDE INTERLEAD FLASH. INTERLEAD FLASH SHALL NOT EXCEED 0.010" (0.254mm) PER SIDE

GN16 (SSOP) 1098

**GN Package
28-Lead Plastic SSOP (Narrow 0.150)**
(LTC DWG # 05-08-1641)

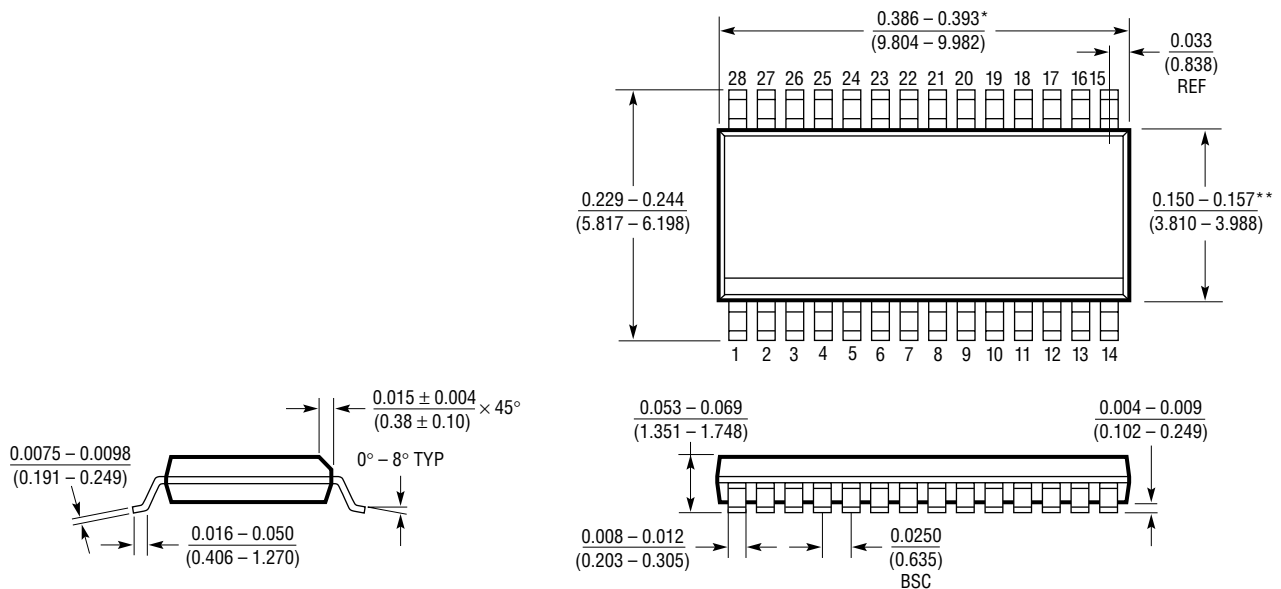

* DIMENSION DOES NOT INCLUDE MOLD FLASH. MOLD FLASH SHALL NOT EXCEED 0.006" (0.152mm) PER SIDE
 ** DIMENSION DOES NOT INCLUDE INTERLEAD FLASH. INTERLEAD FLASH SHALL NOT EXCEED 0.010" (0.254mm) PER SIDE

GN28 (SSOP) 1098

RELATED PARTS

PART NUMBER	DESCRIPTION	COMMENTS
LT1505	High Current Constant-Current/Constant-Voltage Battery Charger Controller with Input Current Limit	High Efficiency Synchronous Buck Topology, Uses External N-Channel FETs. Includes Preset Battery Voltages and Input Current Limiting
LT1510	200kHz Constant-Current/Constant-Voltage Battery Charger	Up to 1.5A Charge Current for Li-Ion, NiCd, NiMH or Lead Acid Batteries
LT1510-5	500kHz Constant-Current/Constant-Voltage Battery Charger	Up to 1A Charge Current for Li-Ion, NiCd, NiMH or Lead Acid Batteries
LT1511	200kHz Constant-Current/Constant-Voltage Battery Charger with Input Current Limit	Up to 3A Charge Current for Li-Ion, NiCd, NiMH or Lead Acid Batteries
LT1512	500kHz SEPIC Constant-Current/Constant-Voltage Battery Charger	Up to 1.5A Charge Current for Li-Ion, NiCd, NiMH or Lead-Acid Batteries. Input Voltage Can be Higher or Lower Than Battery Voltage. 2A Internal Switch
LT1513	500kHz SEPIC Constant-Current/Constant-Voltage Battery Charger	Up to 2A Charge Current for Li-Ion, NiCd, NiMH or Lead-Acid Batteries. Input Voltage Can be Higher or Lower Than Battery Voltage. 3A Internal Switch
LTC®1729	Li-Ion Battery Charger Termination Controller	Can Be Used with Battery Chargers to Provide Charge Termination, Preset Voltages, C/10 Charge Detection and Timer Functions
LTC1731	Linear Constant-Current/Constant-Voltage Charger Controller	Simple Charger Uses External FET. Features Preset Voltages, C/10 Charge Detection and Programmable Timer
LTC1759	SMBus Controlled Constant-Current/Constant-Voltage Smart Battery Charger Controller	LT1505 Charger Functionality with SMBus
LT1769	200kHz Constant-Current/Constant-Voltage Battery Charger with Input Current Limit	Up to 2A Charge Current for Li-Ion, NiCd, NiMH or Lead-Acid Batteries