

FEATURES

- Standard 8-Pin Packages
- High Power Factor Over Wide Load Range with Line Current Averaging
- International Operation Without Switches
- Instantaneous Overvoltage Protection
- Minimal Line Current Dead Zone
- Typical 250µA Start-Up Supply Current
- Rejects Line Switching Noise
- Synchronization Capability
- Low Quiescent Current: 9mA
- Fast 1.5A Peak Current Gate Driver

APPLICATIONS

- Universal Power Factor Corrected Power Supplies
- Preregulators up to 1500W

DESCRIPTION

The 8-pin LT[®]1249 provides active power factor correction for universal offline power systems with very few external parts. By using fixed high frequency PWM current averaging without the need for slope compensation, the LT1249 achieves far lower line current distortion, with a smaller magnetic element than systems that use either peak current detection or zero current switching approach, in both continuous and discontinuous modes of operation.

The LT1249 uses a multiplier containing a square gain function from the voltage amplifier to reduce the AC gain at light output load and thus maintains low line current distortion and high system stability. The LT1249 also provides filtering capability to reject line switching noise which can cause instability when fed into the multiplier. Line current dead zone is minimized with low bias voltage at the current input to the multiplier.

The LT1249 provides many protection features including peak current limiting and overvoltage protection. The switching frequency is internally set at 100kHz.

While the LT1249 simplifies PFC design with minimal parts count, the LT1248 provides flexibilities in switching frequency, overvoltage and current limit.

LT, LTC and LT are registered trademarks of Linear Technology Corporation.

BLOCK DIAGRAM

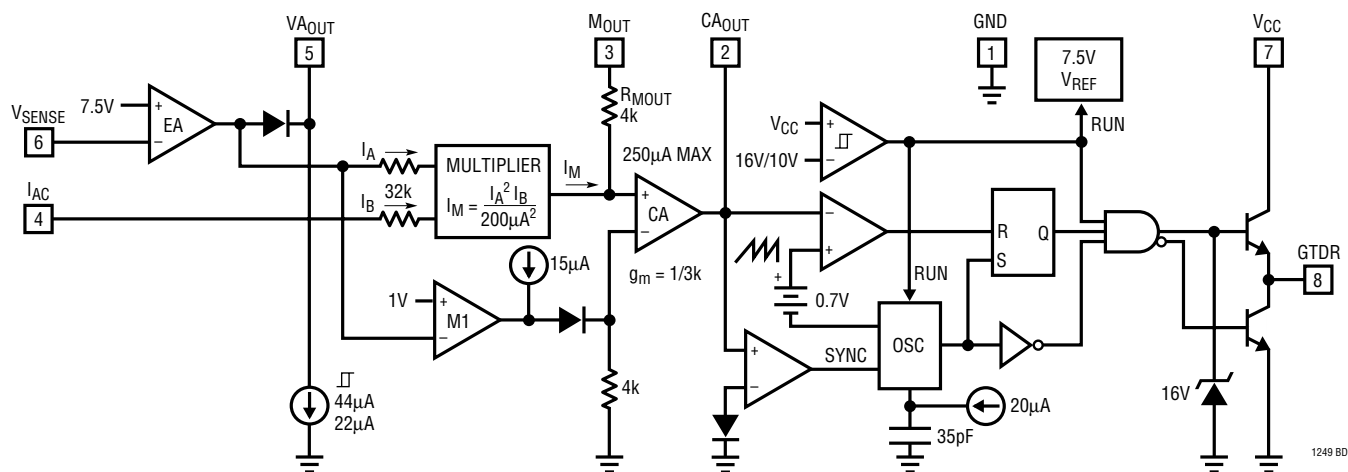

ABSOLUTE MAXIMUM RATINGS

Supply Voltage	27V
GTDR Current Continuous	0.5A
GTDR Output Energy (Per Cycle)	5 μ J
I _{AC} Input Current	20mA
V _{SENSE} Input Voltage	V _{MAX}
M _{OUT} Input Current.....	\pm 5mA
Operating Junction Temperature Range	
LT1249C	0°C to 100°C
LT1249I	-40°C to 125°C
Thermal Resistance (Junction-to-Ambient)	
N8 Package	100°C/W
S8 Package	120°C/W
Storage Temperature Range	-65°C to 150°C
Lead Temperature (Soldering, 10 sec).....	300°C

PACKAGE/ORDER INFORMATION

<p style="text-align: center;">TOP VIEW</p> <p style="text-align: center;">N8 PACKAGE 8-LEAD PDIP</p> <p style="text-align: center;">S8 PACKAGE 8-LEAD PLASTIC SO</p> <p style="text-align: center;">T_{JMAX} = 125°C, θ_{JA} = 100°C/W (N8) T_{JMAX} = 125°C, θ_{JA} = 120°C/W (S8)</p>	ORDER PART NUMBER
	LT1249CN8 LT1249IN8 LT1249CS8 LT1249IS8
	S8 PART MARKING
	1249 1249I

Consult factory for Military grade parts.

ELECTRICAL CHARACTERISTICS

The ● denotes specifications which apply over the operating temperature range, otherwise specifications are at T_A = 25°C. Maximum operating voltage (V_{MAX}) = 25V, V_{CC} = 18V, I_{AC} = 100 μ A, CA_{OUT} = 3.5V, VA_{OUT} = 5V, no load on any outputs, unless otherwise noted.

PARAMETER	CONDITIONS	MIN	TYP	MAX	UNITS	
Overall						
Supply Current (V _{CC} in Undervoltage Lockout)	V _{CC} = Lockout Voltage - 0.2V	●	0.25	0.45	mA	
Supply Current, On	11.5V \leq V _{CC} \leq V _{MAX} , CA _{OUT} = 1V	●	8	12	mA	
V _{CC} Turn-On Threshold		●	15.5	16.5	V	
V _{CC} Turn-Off Threshold		●	9.5	10.5	V	
Voltage Amplifier						
V _{SENSE} Bias Current	V _{SENSE} = 0V to 7V	●	-25	-250	nA	
Voltage Amp Gain			70	100	dB	
Voltage Amp Unity-Gain Bandwidth			1.5		MHz	
Voltage Amp Output High	0 \leq Source Current \leq 50 μ A	●	10	12	V	
Voltage Amp Output Low	0 \leq Sink Current \leq 5 μ A	●	0.1	0.4	V	
Voltage Amp Source Current		●	130	260	450	μ A
Voltage Amp Sink Current Threshold	Linear Operation, 2V < VA _{OUT} < 10V	●	33	44	57	μ A
Voltage Amp Sink Current Hysteresis	2V < VA _{OUT} < 10V	●	14	22.5	30	μ A
Current Amplifier						
Current Amp Offset Voltage		●	\pm 2	\pm 15	mV	
Current Amp Transconductance	Δ I _{CAOUT} = \pm 40 μ A	●	150	320	550	μ mho
Current Amp Voltage Gain	2.5V \leq V _{CAOUT} \leq 7.5V		500	1000	V/V	
Current Amp Source Current	V _{MOUT} = 1V, I _M = 0 μ V		100	145	220	μ A
Current Amp Sink Current	V _{MOUT} = -0.3V, I _M = 0 μ A		67	95	125	μ A
Current Amp Output High			7.4	8.1	V	
Current Amp Output Low			1.2	2	V	

ELECTRICAL CHARACTERISTICS The ● denotes specifications which apply over the operating temperature range, otherwise specifications are at $T_A = 25^\circ\text{C}$. Maximum operating voltage ($V_{\text{MAX}} = 25\text{V}$, $V_{\text{CC}} = 18\text{V}$, $I_{\text{AC}} = 100\mu\text{A}$, $CA_{\text{OUT}} = 3.5\text{V}$, $VA_{\text{OUT}} = 5\text{V}$, no load on any outputs, unless otherwise noted.

PARAMETER	CONDITIONS	MIN	TYP	MAX	UNITS	
Reference						
Reference Output Voltage	$T_A = 25^\circ\text{C}$, Measured at V_{SENSE} Pin		7.39	7.5	7.6	V
Reference Output Voltage Worst Case	All Line, Temperature	●	7.32	7.5	7.68	V
Reference Output Voltage Line Regulation	$V_{\text{LOCKOUT}} < V_{\text{CC}} < V_{\text{MAX}}$	●	-20	5	20	mV
Multiplier						
Multiplier Output Current	$I_{\text{AC}} = 100\mu\text{A}$, $VA_{\text{OUT}} = 5\text{V}$			35		μA
Multiplier Output Current Offset	$R_{\text{AC}} = 1\text{M}$ from I_{AC} to GND	●	-0.05	-0.5		μA
Multiplier Max Output Current ($I_{\text{M(MAX)}}$)	$I_{\text{AC}} = 450\mu\text{A}$, $VA_{\text{OUT}} = 7\text{V}$ (Note 2)	●	-375	-250	-150	μA
Multiplier Max Output Voltage ($I_{\text{M(MAX)}} \cdot R_{\text{MOUT}}$)	$I_{\text{AC}} = 450\mu\text{A}$, $VA_{\text{OUT}} = 7\text{V}$ (Note 2)	●	-1.25	-1.1	-0.96	V
Multiplier Gain Constant (Note 3)				0.035		V^{-2}
I_{AC} Input Resistance	I_{AC} from $50\mu\text{A}$ to 1mA		15	32	50	$\text{k}\Omega$
Oscillator						
Oscillator Frequency		●	75	100	125	kHz
Control Pin (CA_{OUT}) Threshold	Duty Cycle = 0	●	1.3	1.8	2.3	V
Synchronization Frequency Range	Synchronizing Pulse Low $\leq 0.35\text{V}$ on CA_{OUT}	●		127	160	kHz
Gate Driver						
Max GTDR Output Voltage	0mA Load, $18\text{V} < V_{\text{CC}} < V_{\text{MAX}}$ (Note 4)	●	12	15	17.5	V
GTDR Output High	-200mA Load, $11.5\text{V} \leq V_{\text{CC}} \leq 15\text{V}$	●	$V_{\text{CC}} - 3.0$			V
GTDR Output Low (Device Unpowered)	$V_{\text{CC}} = 0\text{V}$, 50mA Load (Sinking)	●		0.9	1.5	V
GTDR Output Low (Device Active)	200mA Load (Sinking)	●		0.5	1	V
Peak GTDR Current	10nF from GTDR to GND			2		A
GTDR Rise and Fall Time	1nF from GTDR to GND			25		ns
GTDR Max Duty Cycle			90	96		%

Note 1: Absolute Maximum Ratings are those values beyond which the life of a device may be impaired.

Note 2: Current amplifier is in linear mode with 0V input common mode.

Note 3: Multiplier Gain Constant: $K = \frac{I_M}{I_{\text{AC}} (VA_{\text{OUT}} - 1.5)^2}$

Note 4: Maximum GTDR output voltage is internally clamped for higher V_{CC} voltages.

TYPICAL PERFORMANCE CHARACTERISTICS

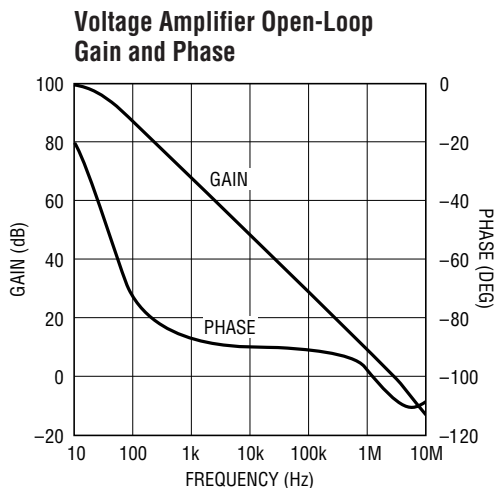

1249 G01

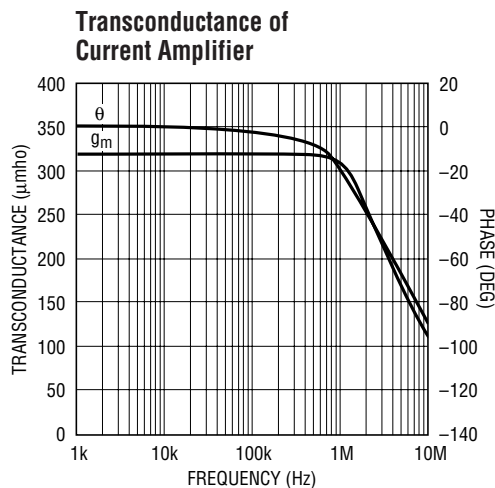

1249 G02

TYPICAL PERFORMANCE CHARACTERISTICS

Reference Voltage vs Temperature

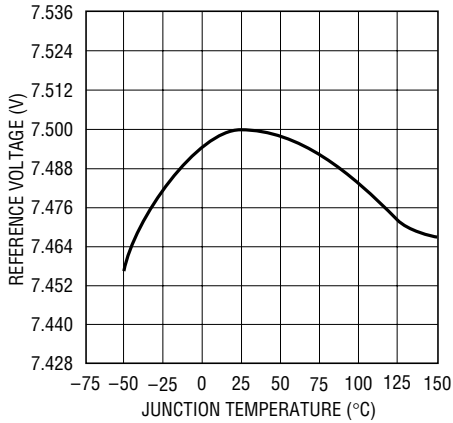

1249 G03

Multiplier Current

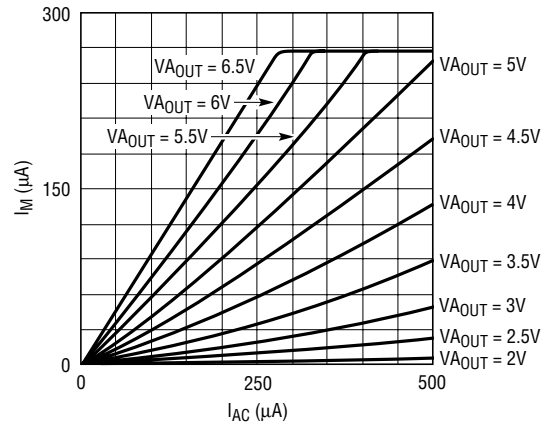

1249 G04

Supply Current vs Supply Voltage

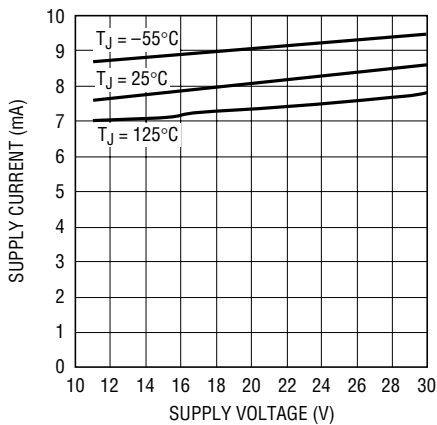

1249 G05

GTDR Source Current

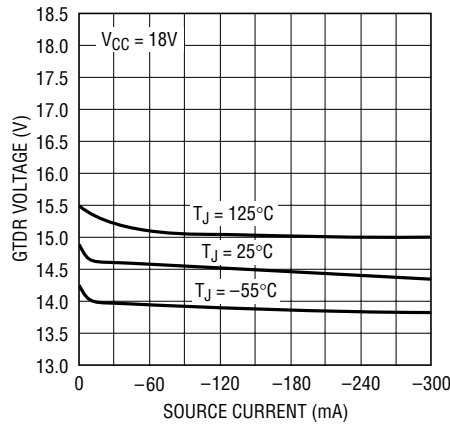

1249 G06

GTDR Sink Current

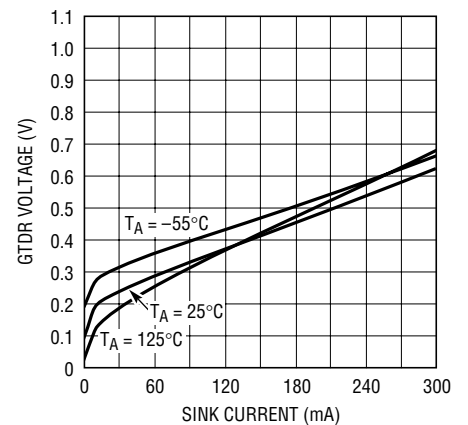

1249 G07

GTDR Rise and Fall Time

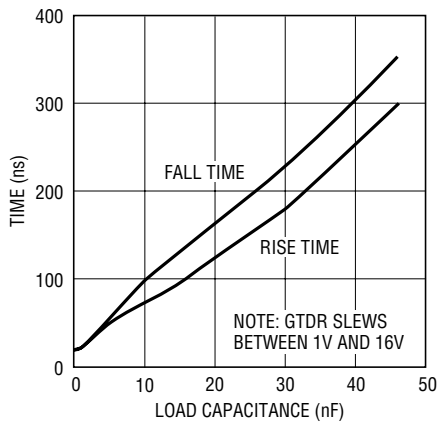

1249 G08

Start-Up Supply Current vs Supply Voltage

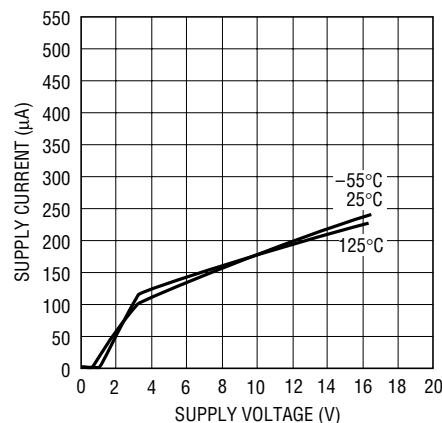

1249 G09

Switching Frequency

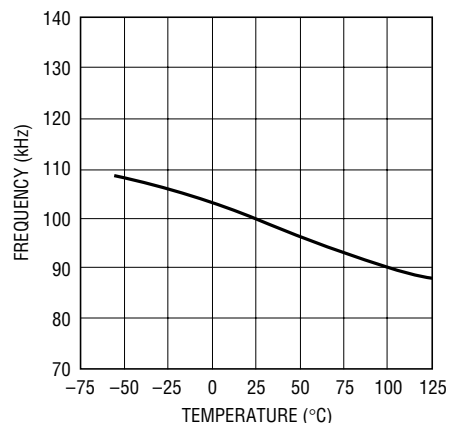

1249 G10

TYPICAL PERFORMANCE CHARACTERISTICS

Synchronization Threshold at CA_{OUT}

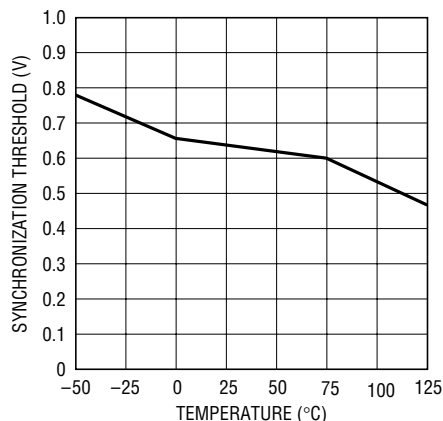

1249 G11

M_{OUT} Pin Characteristics

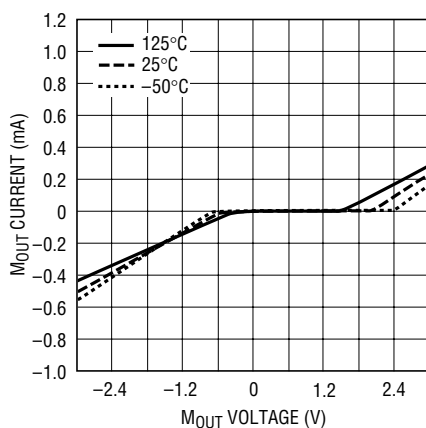

1249 G12

Transconductance of Current Amplifier Over Temperature

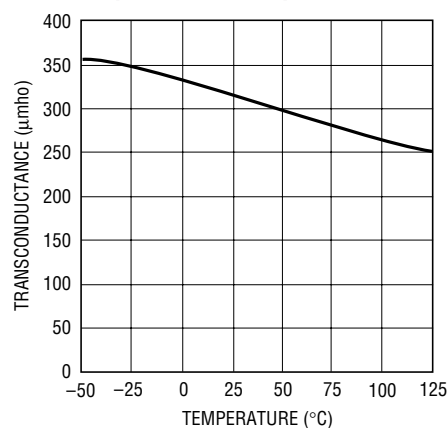

1249 G13

Voltage Amp Sink Current Limits (Threshold)

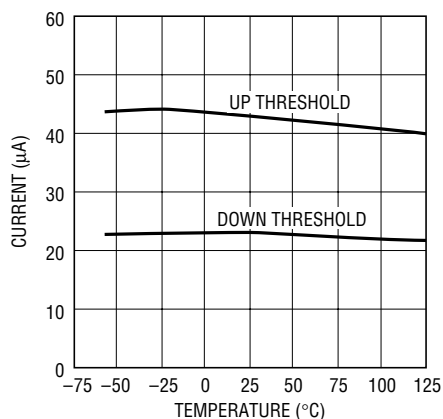

1249 G14

Maximum Multiplier Output Voltage (I_{M(MAX)} • R_{MOUT})

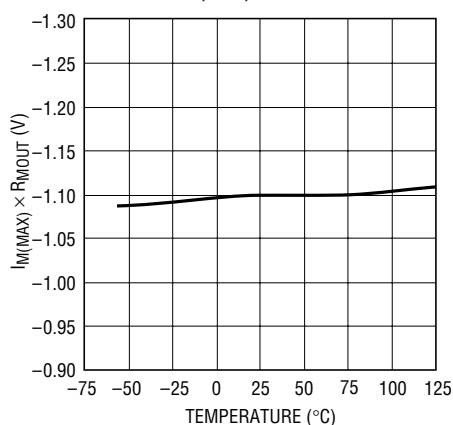

1249 G15

Maximum Duty Cycle

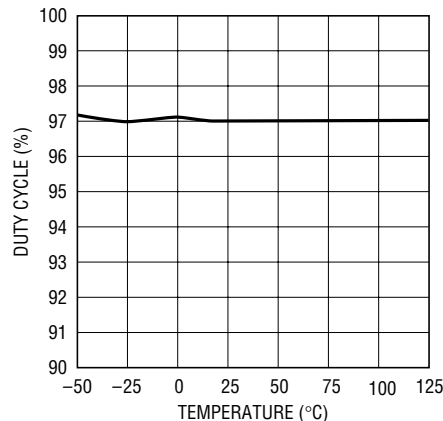

1249 G16

NOTE: THESE SINK CURRENT THRESHOLDS ARE FOR OVERVOLTAGE PROTECTION FUNCTION.

PIN FUNCTIONS

GND (Pin 1): Ground.

CA_{OUT} (Pin 2): This is the output of the current amplifier that senses and forces the line current to follow the reference signal that comes from the multiplier by commanding the pulse width modulator. When CA_{OUT} is low, the modulator has zero duty cycle.

M_{OUT} (Pin 3): The multiplier current goes out of this pin through the 4k resistor R_{MOUT}. The voltage developed across R_{MOUT} is the reference voltage of the current loop and it is limited to 1.1V. The noninverting input of the current amplifier is also tied to R_{MOUT}. In operation, M_{OUT}

is normally at negative potential and only AC signals appear at the noninverting input of the current amplifier.

I_{AC} (Pin 4): This is the AC line voltage sensing input to the multiplier. It is a current input that is biased at 2V to minimize the crossover dead zone caused by low line voltage. A 32k resistor is in series with the current input, so that a small external capacitor can be used to filter out the switching noise from the high impedance lines.

VA_{OUT} (Pin 5): This is the output of the voltage error amplifier. The output is clamped at 12V. When the output goes below 1.5V, the multiplier output current is zero.

PIN FUNCTIONS

V_{SENSE} (Pin 6): This is the inverting input to the voltage amplifier.

V_{CC} (Pin 7): This is the supply of the chip. The LT1249 has a very fast gate driver required to fast charge high power MOSFET gate capacitance. High current spikes occur during charging. For good supply bypass, a 0.1μF ceramic

capacitor in parallel with a low ESR electrolytic capacitor, 56μF or higher is required in close proximity to IC GND.

GTDR (Pin 8): The MOSFET gate driver is a 1.5A fast totem pole output. It is clamped at 15V. Capacitive loads like MOSFET gates may cause overshoot. A gate series resistor of at least 5Ω will prevent the overshoot.

APPLICATIONS INFORMATION

Error Amplifier

The error amplifier has a 100dB DC gain and 1.5MHz unity-gain frequency. It is internally clamped at 12V. The noninverting input is tied to the 7.5V reference.

Current Amplifier

The multiplier output current I_M flows out of the M_{OUT} pin through the 4k resistor R_{MOUT} and develops the reference signal to the current loop that is controlled by the current amplifier. Current gain is the ratio of R_{MOUT} to line current sense resistor. The current amplifier is a transconductance amplifier. Typical g_m is 320μmho and gain is 60dB with no load. The inverting input is internally tied to GND. The noninverting input is tied to the multiplier output. The output is internally clamped at 8V. Output resistance is about 4M; DC loading should be avoided because it will lower the gain and introduce offset voltage at the inputs which becomes a false reference signal to the current loop and can distort line current. Note that in the current averaging operation, high gain at twice the line frequency is necessary to minimize line current distortion. Because CA_{OUT} may need to swing 5V over one line cycle at high line condition, 11mV will be present at the inputs of the current amplifier if gain is rolled off to 450 at 120Hz (1nF in series with 10k at CA_{OUT}). At light load, when $(I_M)(R_{MOUT})$ can be less than 100mV, lower gain will distort the current loop reference signal and line current. If signal gain at the 100kHz switching frequency is too high, the system behaves more like a current mode system and can cause subharmonic oscillation. Therefore, the current amplifier should be compensated to have a gain of less than 15 at 100kHz and more than 300 at 120Hz.

Multiplier

The multiplier is a current multiplier with high noise immunity in a high power switching environment. The current gain is:

$$I_M = (I_{AC})(I_{EA}^2)/(200\mu A)^2, \text{ and}$$

$$I_{EA} = (V_{AOUT} - 1.5V)/25k$$

With a square function, because of the lower gain at light power load, system stability is maintained and line current distortion caused by the AC ripple fed back to the error amplifier is minimized. Note that switching ripple on the high impedance lines could get into the multiplier from the I_{AC} pin and cause instability. The LT1249 provides an internal 25k resistor in series with the low impedance multiplier current input so that only a capacitor from the I_{AC} pin to GND is needed to filter out the noise. Maximum multiplier output current is limited to 250μA. Figure 1 shows the multiplier transfer curves.

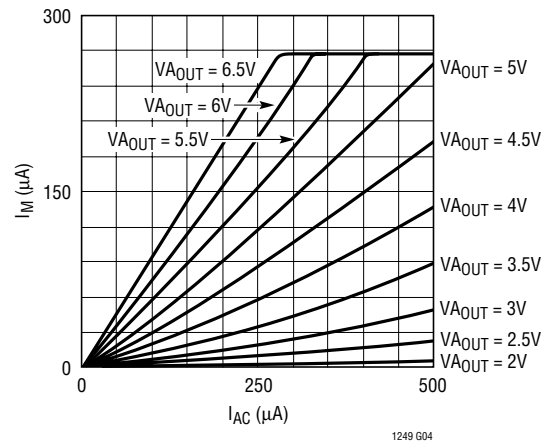

Figure 1. Multiplier Current I_M vs I_{AC} and V_{AOUT}

APPLICATIONS INFORMATION

Line Current Limiting

Maximum voltage across R_{MOUT} is internally limited to 1.1V. Therefore, line current limit is 1.1V divided by the sense resistor R_S . With a 0.2Ω sense resistor R_S line current limit is 5.5A. As a general rule, R_S is chosen according

$$R_S = \frac{(I_{M(MAX)})(R_{MOUT})(V_{LINE(MIN)})}{K(1.414)P_{OUT(MAX)}}$$

where $P_{OUT(MAX)}$ is the maximum power output and K is usually between 1.1 and 1.3 depending on efficiency and resistor tolerance. When the output is overloaded and line current reaches limit, output voltage V_{OUT} will drop to keep line current constant. System stability is still maintained by the current loop which is controlled by the current amplifier. Further load current increase results in further V_{OUT} drop and clipping of the line current, which degrades power factor.

Synchronization

The LT1249 can be externally synchronized in a frequency range of 127kHz to 160kHz. Figure 2 shows the synchronizing circuit. Synchronizing occurs when CA_{OUT} pin is pulled below 0.5V with an external transistor and a Schottky diode. The Schottky diode and the 10k pull-up resistor are necessary for the required fast slewing back up to the normal operating voltage on CA_{OUT} after the transistor is turned off. Positive slewing on CA_{OUT} should be faster than the oscillator ramp rate of $0.5V/\mu s$.

The width of the synchronizing pulse should be under 60ns. The synchronizing pulses introduce an offset voltage on the current amplifier inputs, according to:

$$\Delta V_{Os} = \frac{(ts)(fs) \left(I_C + \frac{V_C - 0.5}{R_2} \right)}{g_m}$$

ts = pulse width

fs = pulse frequency

I_C = CA_{OUT} source current ($\approx 150\mu A$)

V_C = CA_{OUT} operating voltage (1.8V to 6.8V)

R_2 = resistor for the midfrequency “zero” in the current loop

g_m = current amplifier transconductance ($\approx 320\mu mho$)

With $ts = 30ns$, $fs = 130kHz$, $V_C = 3V$ and $R_2 = 10k$, offset voltage shift is $\approx 5mV$. Note that this offset voltage will add slight distortion to line current at light load.

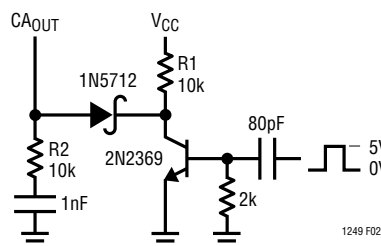

Figure 2. Synchronizing the LT1249

Overvoltage Protection

In Figure 3, R_1 and R_2 set the regulator output DC level: $V_{OUT} = V_{REF}[(R_1 + R_2)/R_2]$. With $R_1 = 1M$ and $R_2 = 20k$, V_{OUT} is 382V.

Because of the slow loop response necessary for power factor correction, output overshoot can occur with sudden load removal or reduction. To protect the power components and output load, the LT1249 voltage error amplifier senses the output voltage and quickly shuts off the current switch when overvoltage occurs. When overshoot occurs on V_{OUT} , the overcurrent from R_1 will go through VA_{OUT} because amplifier feedback keeps V_{SENSE} locked at 7.5V. When this overcurrent reaches $44\mu A$ amplifier sinking limit, the amplifier loses feedback and its output snaps low to turn the multiplier off.

Overvoltage trip level: $\Delta V_{OUT} = (44\mu A)(R_1)$

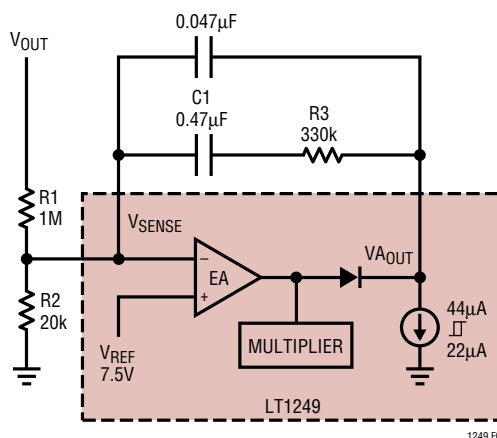

Figure 3. Overvoltage Protection

APPLICATIONS INFORMATION

The Figure 3 circuit therefore has 382V on V_{OUT} , and an overvoltage level = $(V_{OUT} + 44V)$, or 426V. With a 22 μ A hysteresis, V_{OUT} then has to drop 22V to 404V before feedback recovers and the switch turns back on.

M_{OUT} is a high impedance current output. In the current loop, offset line current is determined by multiplier offset current and input offset voltage of the current amplifier. A negative 4mV current amplifier V_{OS} translates into 20mA line current and 5W input power for 250V line if 0.2 Ω sense resistor is used. Under no load or when the load power is less than this offset input power, V_{OUT} would slowly charge up to an overvoltage state because the overvoltage comparator can only reduce multiplier output current to zero. This does not guarantee zero output current if the current amplifier has offset. To regulate V_{OUT} under this condition, the amplifier M1 (see Block Diagram), becomes active in the current loop when V_{AOUT} goes down to 1V. The M1 can put out up to 15 μ A to the 4k resistor at the inverting input to cancel the current amplifier negative V_{OS} and keep V_{OUT} error to within 2V.

Undervoltage Lockout

The LT1249 turns on when V_{CC} is higher than 16V and remains on until V_{CC} falls below 10V, whereupon the chip enters the lockout state. In the lockout state, the LT1249 only draws 250 μ A, the oscillator is off, the V_{REF} and the GTDR pins remain low to keep the power MOSFET off.

Start-Up and Supply Voltage

The LT1249 draws only 250 μ A before the chip starts at 16V on V_{CC} . To trickle start, a 90k resistor from the power line to V_{CC} supplies the trickle current and C4 holds the V_{CC} up while switching starts (see Figure 4). Then the auxiliary winding takes over and supplies the operating current. Note that D3 and the large value C3, in both Figures 4 and 5, are only necessary for systems that have sudden large load variation down to minimum load and/or very light load conditions. Under these conditions, the loop may exhibit a start/restart mode because switching remains off long enough for C4 to discharge below 10V. The C3 will hold V_{CC} up until switching resumes. For less severe load variations, D3 is replaced with a short and C3 is omitted. The turns ratio between the primary winding and the

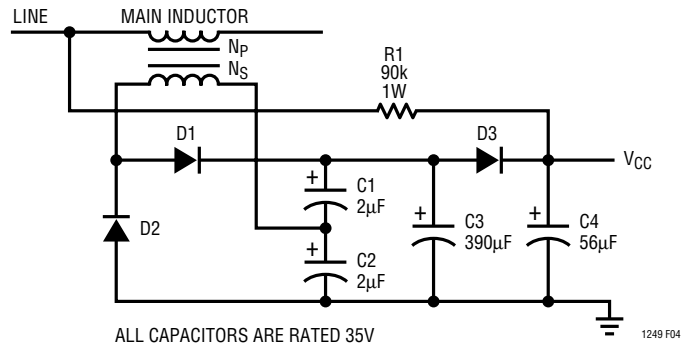

Figure 4. Power Supply for LT1249

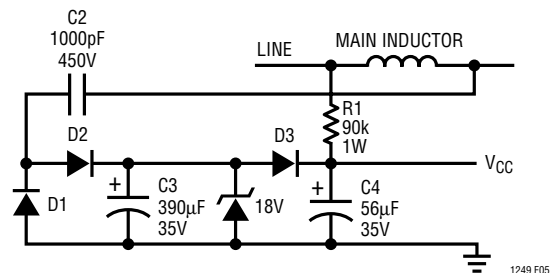

Figure 5. Power Supply for LT1249

auxiliary winding determines V_{CC} according to: $V_{OUT}/(V_{CC} - 2V) = N_P/N_S$. For 382V V_{OUT} and 18V V_{CC} , $N_P/N_S \approx 19$.

In Figure 5 a new technique for supply voltage eliminates the need for an extra inductor winding. It uses capacitor charge transfer to generate a constant current source which feeds a Zener diode. Current to the Zener is equal to $(V_{OUT} - V_Z)(C)(f)$, where V_Z is Zener voltage and f is switching frequency. For $V_{OUT} = 382V$, $V_Z = 18V$, $C = 1000pF$ and $f = 100kHz$, Zener current will be 36mA. This is enough to operate the LT1249, including the FET gate drive.

Output Capacitor

The peak-to-peak 120Hz output ripple is determined by:

$$V_{P-P} = (2)(I_{LOADDC})(Z)$$

where I_{LOADDC} : DC load current

Z: capacitor impedance at 120Hz

For 180 μ F at 300W load, $I_{LOADDC} = 300W/385V = 0.78A$,

APPLICATIONS INFORMATION

$V_{P-P} = (2)(0.78A)(7.4\Omega) = 11.5V$. If less ripple is desired, higher capacitance should be used.

The selection of the output capacitor should also be based on the operating ripple current through the capacitor.

The ripple current can be divided into three major components. The first is at 120Hz whose RMS value is related to the DC load current as follows:

$$I_{1RMS} \approx (0.71)(I_{LOADDC})$$

The second component contains the PF switching frequency ripple current and its harmonics. Analysis of this ripple is complicated because it is modulated with a 120Hz signal. However, computer numerical integration and Fourier analysis approximate the RMS value reasonably close to the bench measurements. The RMS value is about 0.82A at a typical condition of 120VAC, 200W load. This ripple is line voltage dependent, and the worst case is at low line.

$$I_{2RMS} = 0.82A \text{ at } 120VAC, 200W$$

The third component is the switching ripple from the load, if the load is a switching regulator.

$$I_{3RMS} \approx I_{LOADDC}$$

For United Chemicon KMH 400V capacitor series, ripple current multiplier for currents at 100kHz is 1.43. The equivalent 120Hz ripple current can then be found:

$$I_{RMS} = \sqrt{(I_{1RMS})^2 + \left(\frac{I_{2RMS}}{1.43}\right)^2 + \left(\frac{I_{3RMS}}{1.43}\right)^2}$$

For a typical system that runs at an average load of 200W and 385V output:

$$I_{LOADDC} = 0.52A$$

$$I_{1RMS} \approx (0.71)(0.52A) = 0.37A$$

$$I_{2RMS} \approx 0.82A \text{ at } 120VAC$$

$$I_{3RMS} \approx I_{LOADDC} = 0.52A$$

$$I_{RMS} = \sqrt{(0.37A)^2 + \left(\frac{0.82A}{1.43}\right)^2 + \left(\frac{0.52A}{1.43}\right)^2} = 0.77A$$

The 120Hz ripple current rating at 105°C ambient is 0.95A for the 180μF KMH 400V capacitor. The expected life of the output capacitor may be calculated from the thermal stress analysis:

$$L = (L_0)(2)^{\frac{(105^\circ C + \Delta T_K) - (T_{AMB} + \Delta T_O)}{10}}$$

where

L = expected life time

L_0 = hours of load life at rated ripple current and rated ambient temperature

ΔT_K = capacitor internal temperature rise at rated condition. $\Delta T_K = (I^2R)/(KA)$, where I is the rated current, R is capacitor ESR, and KA is a volume constant.

T_{AMB} = operating ambient temperature

ΔT_O = capacitor internal temperature rise at operating condition

In our example, $L_0 = 2000$ hours and $\Delta T_K = 10^\circ C$ at rated 0.95A. ΔT_O can then be calculated from:

$$\Delta T_O = \left(\frac{I_{RMS}}{0.95A}\right)^2 (\Delta T_K) = \left(\frac{0.77A}{0.95A}\right)^2 (10^\circ C) = 6.6^\circ C$$

Assuming the operating ambient temperature is 60°C, the approximate life time is:

$$L_0 \approx (2000)(2)^{\frac{(105^\circ C + 10^\circ C) - (60^\circ C + 6.6^\circ C)}{10}} \approx 57,000 \text{ Hrs.}$$

For longer life, capacitor with higher ripple current rating or parallel capacitors should be used.

Protection Against Abnormal Current Surge Conditions

The LT1249 has an upper limit on the allowed voltage across the current sense resistor. The voltage into the M_{OUT} pin connected to this resistor must not exceed $-6V$ while the chip is running and $-12V$ under any conditions. The LT1249 gate drive will malfunction if the M_{OUT} pin voltage exceeds $-6V$ while V_{CC} is powered, destroying the power FET. The 12V absolute limit is imposed by ESD clamps on the M_{OUT} pin. Large currents will flow at

APPLICATIONS INFORMATION

voltages above 8V and the 12V limit is only for surge conditions.

In normal operation, the voltage into M_{OUT} does not exceed 1.1V, but under surge conditions, the voltage could temporarily go higher. To date, no field failures due to surges have been reported for normal LT1249 configurations, but if the possibility exists for extremely large current surges, please read the following discussion.

Offline switching power supplies can create large current surges because of the high value storage capacitor used. The surge can be the result of closing the line switch near the peak of the AC line voltage, or because of a large transient in the line itself. These surges are well known in the power supply business, and are normally controlled with a negative temperature coefficient thermistor in series with the rectifier bridge. When power is switched on, the thermistor is cold (high resistance) and surges are limited. Current flow in the thermistor causes it to heat and resistance drops to the point where overall efficiency loss in the resistor is acceptable.

This basic protection mechanism can be partially defeated if the power supply is switched off for a few seconds, then turned back on. The thermistor has not had time to cool significantly and if the subsequent turn-on catches the AC line near its peak, the resulting surge is much higher than normal. Even if this surge current generates a voltage greater than 6V (but less than 12V) across the sense

resistor, the standard LT1249 application will not be affected because the chip is not yet powered. Problems are only created if the V_{CC} pin is powered from some external housekeeping supply that remains powered when bridge power is switched off.

A huge line voltage surge, *beyond the normal worst-case limits*, can also create a large current surge. The peak of the line voltage must significantly exceed the storage capacitor voltage (typically 380V) for this to occur, so peak line voltage would probably have to exceed 450V. Such excessive surges might occur if a very large mains load was suddenly removed, with a resulting line “kickback”. If the surge results in voltage at the M_{OUT} pin greater than 6V, it must also last more than 30 μ s (three switch cycles) to cause FET problems.

External Clamp

The external clamp shown in Figure 6 will protect the LT1249 M_{OUT} pin against extremely large line current surges (see above). Protection is provided for all V_{CC} power methods. The 100 Ω resistor and three diodes limit the peak negative voltage into M_{OUT} to less than 3V. Current sense gain is attenuated by only 100 Ω /4000 Ω = 2.5%. Three diodes are used because the peak negative voltage into M_{OUT} in normal operation could go as high as -1.1V and the diodes should not conduct more than a few microamps under this condition.

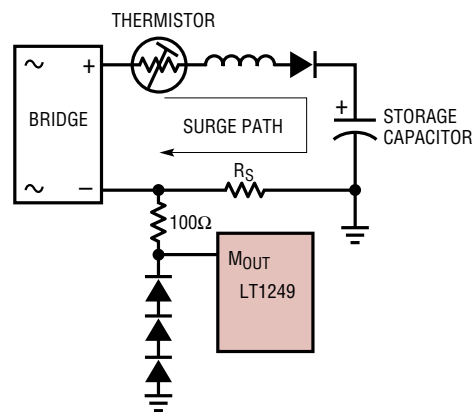
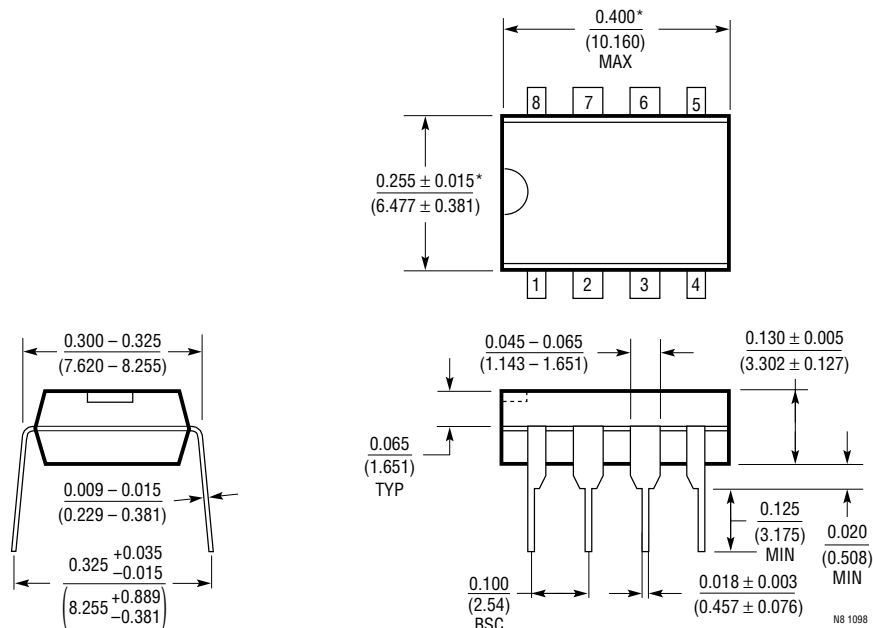

Figure 6. Protecting M_{OUT} from Extremely High Current Surges

PACKAGE DESCRIPTION

Dimensions in inches (millimeters) unless otherwise noted.

**N8 Package
8-Lead PDIP (Narrow 0.300)**
(LTC DWG # 05-08-1510)



*THESE DIMENSIONS DO NOT INCLUDE MOLD FLASH OR PROTRUSIONS.
MOLD FLASH OR PROTRUSIONS SHALL NOT EXCEED 0.010 INCH (0.254mm)

**S8 Package
8-Lead Plastic Small Outline (Narrow 0.150)**
(LTC DWG # 05-08-1610)

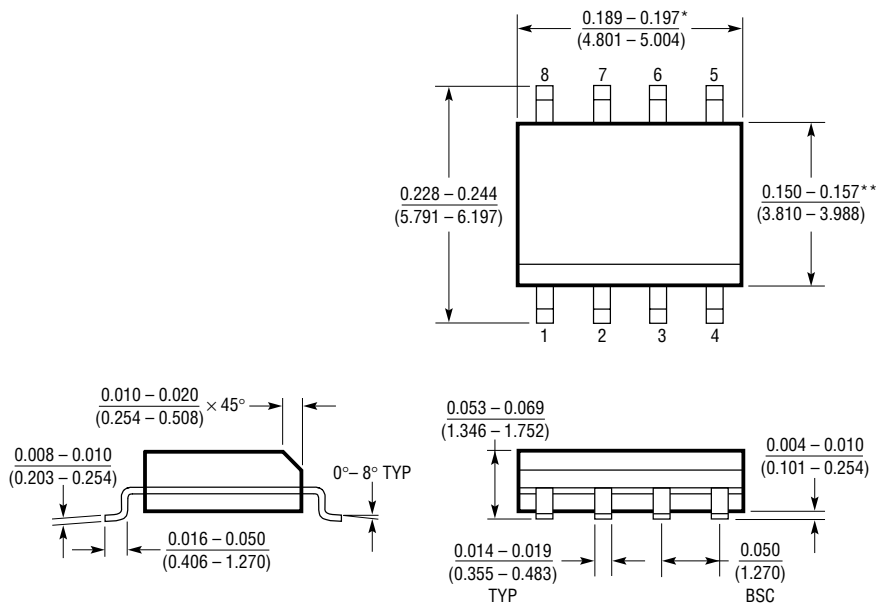

*DIMENSION DOES NOT INCLUDE MOLD FLASH. MOLD FLASH SHALL NOT EXCEED 0.006" (0.152mm) PER SIDE

**DIMENSION DOES NOT INCLUDE INTERLEAD FLASH. INTERLEAD FLASH SHALL NOT EXCEED 0.010" (0.254mm) PER SIDE

S08 1298

TYPICAL APPLICATION

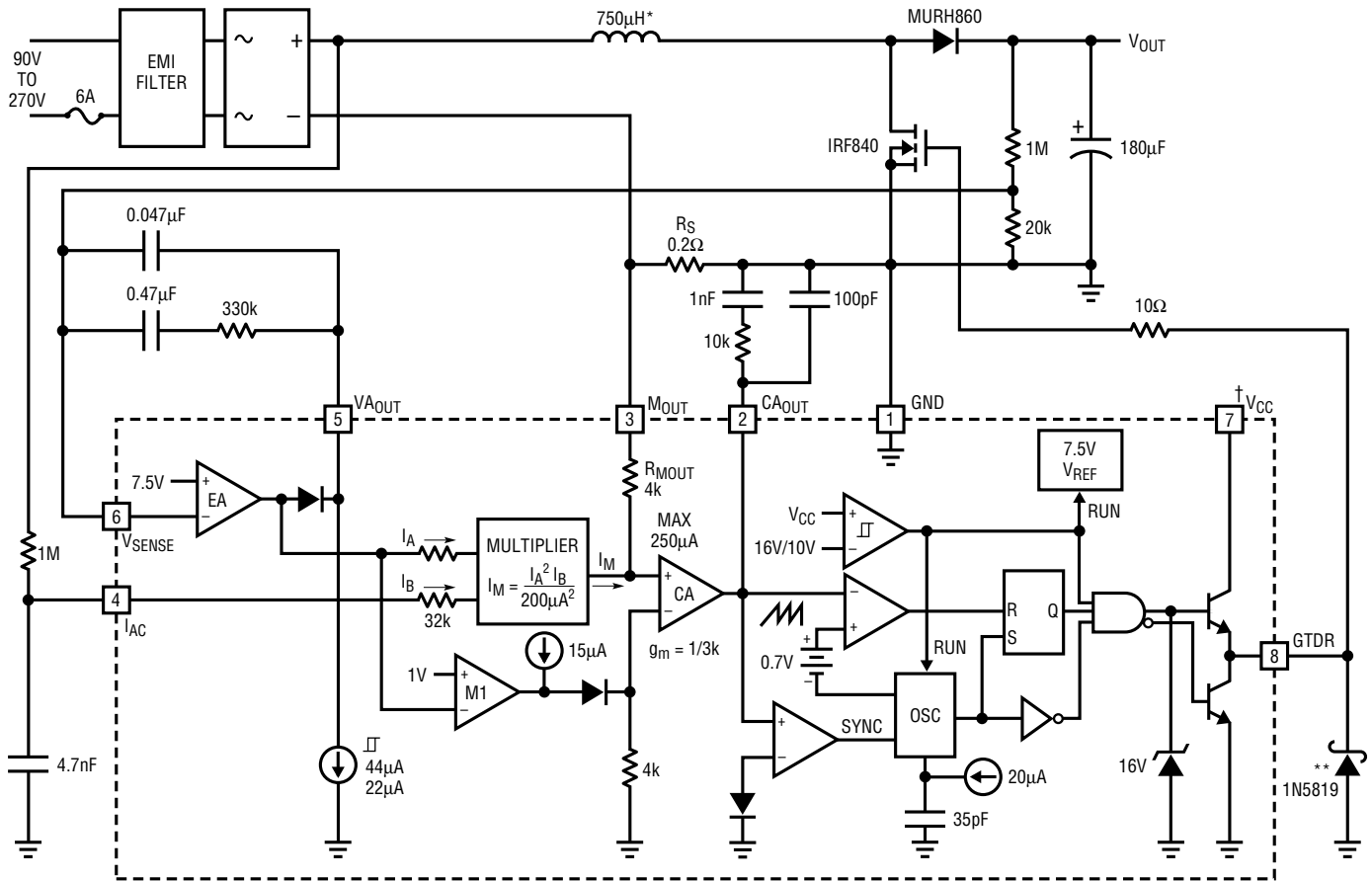

* 1. COILTRONICS CTX02-12236 (TYPE 52 CORE)
AIR MOVEMENT NEEDED AT POWER LEVEL GREATER THAN 250W.

2. COILTRONICS CTX02-12295 (MAGNETICS Kool Mµ® 77930 CORE)

** THIS SCHOTTKY DIODE IS TO CLAMP GTDR WHEN MOS SWITCH TURNS OFF. PARASITIC INDUCTANCE AND GATE CAPACITANCE MAY TURN ON CHIP SUBSTRATE DIODE AND CAUSE ERRATIC OPERATIONS IF GTDR IS NOT CLAMPED.

† SEE APPLICATIONS INFORMATION SECTION FOR CIRCUITRY TO SUPPLY POWER TO VCC.

1249 TA01

RELATED PARTS

PART NUMBER	DESCRIPTION	COMMENTS
LT1103	Off-Line Switching Regulator	Universal Off-Line Inputs with Outputs to 100W
LT1248	Full Feature Average Current Mode Power Factor Controller	Provides All Features in 16-Lead Package
LT1508	Power Factor and PWM Controller	Simplified PFC Design
LT1509	Power Factor and PWM Controller	Complete Solution for Universal Off-Line Switching Power Supplies

Kool Mµ is a registered trademark of Magnetics, Inc.