

# Dot Matrix LED Unit for Indoor Use LT1461ED(Chip On Board Type)

## ■ Features

- No. of dots : 16X16dots
- Outline dimensions : 64X64mm
- Dot size :  $\phi$ 2.8mm
- Dot pitch : 4.0mm
- Radiation color : Yellow-green+Red(dichromatic type)
- Driving method : 1/16 duty dynamic drive



LT1461ED

## ■ Absolute Maximum Ratings

(Ta=25°C)

Parameter	Symbol	Rating	Unit
Supply voltage for IC	VCC	6.0	V
Supply voltage for LED	VLED	6.0	V
Input voltage	VI	-0.3 to +5.5	V
Turn-on time	ton	1	ms
Operating temperature	Topr	-10 to +45	°C
Storage temperature	Tstg	-20 to +70	°C
Power dissipation	P	13	W

## ■ Optical Characteristics

(VCC=5V, VLED=5V, Ta=25°C)

Parameter	Symbol	TYP	Unit
Luminance	Red	90	cd/m <sup>2</sup>
	Yellow-green	90	
Viewing angle	2 $\theta$ <sup>1/2</sup>	80	°
Peak emission wavelength	Red	635	nm
	Yellow-green	565	

## ■ Terminal Functions

Connector	Symbol	Function
Power supply (CN1)	VLED	Supply voltage for LED (+5V)
	VCC	Supply voltage for IC (+5V)
	GND1	Ground for IC
	GND2	Ground for LED
Input signal (CN2)	A0 to A3	Address specification signal for row driver
	RDATA	Serial data input for red (H=ON, L=OFF)
	GDATA	Serial data input for yellow-green (H=ON, L=OFF)
	LATCH	Latch signal of display data. L: Contents are latched.
	ENABLE	Controls ON/OFF of LED (H: LED OFF)
	CLOCK	Clock signal for data transmission in the shift-register. (L→H: serial data is shifted.)
Output signal (CN3)	GND1	Ground for signal. (Connected to ground for IC)
	A0 to A3	Buffered input signal
	RDATA	Input signal generated through 16-bit shift register or buffer
	GDATA	Input signal generated through 16-bit shift register or buffer
	LATCH	Buffered input signal
	ENABLE	Buffered input signal
	CLOCK	Buffered input signal
GND1	Ground for signal. (Connected to ground for IC)	

Each signal is used as input signal for next unit.

\* As for the terminal number, refer to the outline dimensions.

## ■ Electrical Characteristics

(VCC=5V, VLED=5V, Ta=25°C)

Parameter	Symbol	MIN.	TYP.	MAX.	Unit
Supply voltage for IC	VCC	4.75	5.0	5.25	V
Supply voltage for LED	VLED	—	5.0	5.25	V
IC current dissipation*1	ICC	—	50	—	mA
LED current dissipation*1	ILED	—	1.8	—	A
Input voltage	VIH	3.5	—	—	V
	VIL	—	—	1.5	V
Input current	IiH	—	—	0.1	$\mu$ A
	IiL	—	—	0.12	mA
Clock frequency	fCLK	—	—	4	MHz
Frame frequency	fFR	80	—	625	Hz

\*1 Under the condition that dichromatic all dots are lit.

## ■ Timing Chart

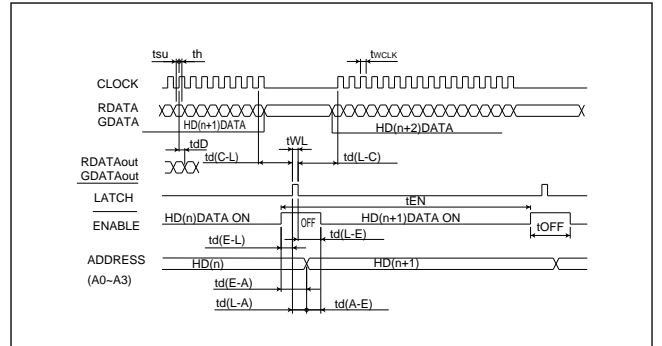

## ■ Block Diagram

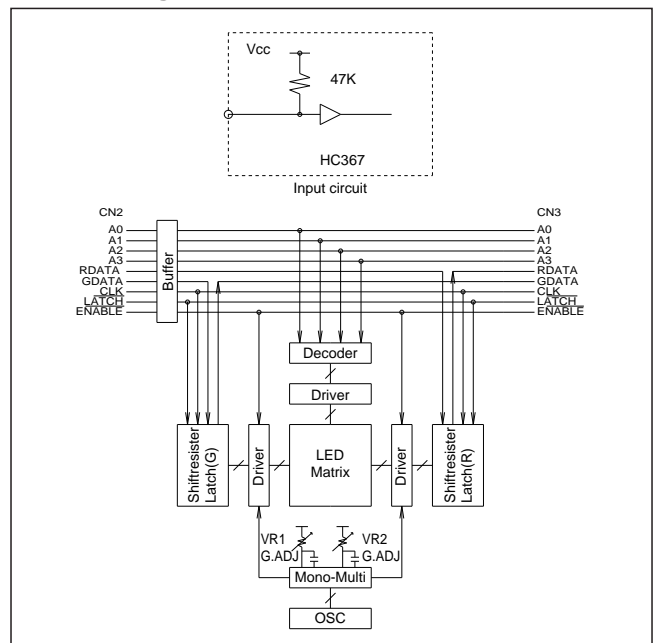

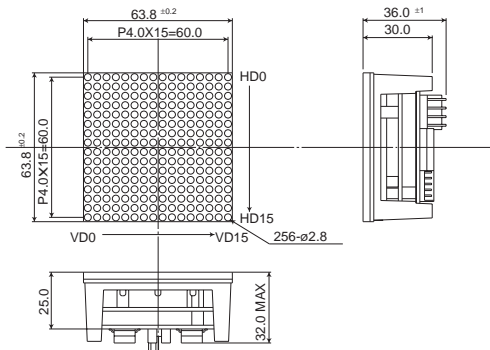

## Pin connection

CN1  
(Power supply)

1	V <sub>LED</sub>
2	V <sub>CC</sub>
3	GND1
4	GND2

CN2  
(Input signal)

1	A <sub>0</sub>
2	A <sub>1</sub>
3	A <sub>2</sub>
4	A <sub>3</sub>
5	RDATA
6	GDATA
7	LATCH
8	ENABLE
9	CLOCK
10	GND1

CN3  
(Output signal)

1	A <sub>0</sub>
2	A <sub>1</sub>
3	A <sub>2</sub>
4	A <sub>3</sub>
5	RDATA
6	GDATA
7	LATCH
8	ENABLE
9	CLOCK
10	GND1