

# Product Information

ISSUE DATE : 98-12-23  
MODEL : LT150X1-151

NOTE : This product information is subject to change after 3 months of issuing date.

PREPARED BY : AMLCD Application Engineering Group

**SAMSUNG ELECTRONICS CO., LTD.**

**SAMSUNG**

ELECTRONICS

## CONTENTS

|  |              |
|--|--------------|
| General Description  | ----- ( 3 )  |
| 1. Electrical Absolute Characteristics                               | ----- ( 4 )  |
| 1.1 TFT LCD Module   |              |
| 1.2 Back-light Unit  |              |
| 2. Optical Characteristics   | ----- ( 5 )  |
| 3. Electrical Characteristics  | ----- ( 8 )  |
| 3.1 TFT LCD Module   |              |
| 3.2 Back-light Unit  |              |
| 4. Block Diagram   | ----- ( 11 ) |
| 4.1 TFT LCD Module   |              |
| 4.2 Back-light Unit  |              |
| 5. Input Terminal Pin Assignment                                     | ----- ( 12 ) |
| 5.1 Input signal & Power   |              |
| 5.2 Back-light Unit  |              |
| 5.3 Input Signal, Basic Display Colors and Gray Scale of Each Colors |              |
| 6. Interface Timing  | ----- ( 15 ) |
| 6.1 Timing Parameters (Sync & DE mode)                               |              |
| 6.2 Timing Diagrams of interface Signal (Sync & DE mode)             |              |
| 6.3 Timing Parameters (DE only mode)                                 |              |
| 6.4 Timing Diagrams of interface signal (DE only mode)               |              |
| 6.5 Power ON/OFF Sequence  |              |
| 7. Outline Dimension   | ----- ( 20 ) |
| 8. General Precautions   | ----- ( 21 ) |
| 8.1 Handling   |              |
| 8.2 Storage  |              |
| 8.3 Operation  |              |
| 8.4 Others   |              |

## GENERAL DESCRIPTION

### DESCRIPTION

LT150X1-151 is a color active matrix TFT (Thin Film Transistor) liquid crystal display (LCD) that uses amorphous silicon TFT switching devices. This model is composed of a TFT LCD panel, a driver circuit and a back-light system. The resolution of 15.0- inch contains 1,024 x 768 pixels and can display up to 262,144 colors. 6 o'clock direction is the optimum viewing angle.

### FEATURES

- High contrast ratio, High aperture structure
- Wide viewing angle
- High-speed response
- XGA(1024x768 pixels) resolution
- Low power consumption
- 2 Dual CCFTs (Cold Cathode Fluorescent Tube)
- Sync&DE (Data Enable) Mode and DE only Mode
- TTL Interface with 2 pixels / clock

### APPLICATIONS

- Desktop monitors
- Display terminals for AV application products
- Monitors for Industrial machine

### GENERAL SPECIFICATIONS

| ITEM              | SPECIFICATION                              | UNIT  | NOTE |
|-------------------|--|-------|------|
| Display area      | 304.128(H) x228.096(V) (15 inch diagonal ) | mm    |      |
| Driver element    | a-Si TFT active matrix                     |       |      |
| Display colors    | 262,144                                    |       |      |
| Number of pixel   | 1024 x 768                                 | pixel |      |
| Pixel arrangement | RGB vertical stripe                        |       |      |
| Pixel pitch       | 0.297(H) x 0.297(W)                        | mm    |      |
| Display Mode      | Normally white                             |       |      |
| Surface treatment | Haze 13 , Hard - Coating (3H)              |       |      |



ELECTRONICS

## Mechanical Information

| ITEM        |                | MIN. | TYP. | MAX. | NOTE |
|-------------|----------------|------|------|------|------|
| Module size | Horizontal (H) | -    | 368  | -    | mm   |
|             | Vertical (V)   | -    | 275  | -    | mm   |
|             | Depth (D)      | -    | -    | 20   | mm   |
| Weight      |                | -    | -    | 1550 | g    |

## 1. ELECTRICAL ABSOLUTE RATINGS

### 1.1 TFT LCD MODULE

( $V_{SS} = GND = 0\text{ V}$ )

| ITEM                 | SYMBOL   | MIN.         | MAX. | UNIT | NOTE |
|----------------------|----------|--------------|------|------|------|
| Power Supply Voltage | $V_{DD}$ | $V_{SS}-0.3$ | 6.0  | V    | (1)  |

NOTE (1) Within  $T_a$  ( $25 \pm 2\text{ }^\circ\text{C}$ )

### 1.2 BACK-LIGHT UNIT

$T_a = 25 \pm 2\text{ }^\circ\text{C}$

| ITEM           | SYMBOL | MIN. | MAX. | UNIT. | NOTE    |
|----------------|--------|------|------|-------|---------|
| Lamp current   | $I_L$  | 4.0  | 12.0 | mArms | (1),(2) |
| Lamp frequency | $f_L$  | 30   | 80   | KHz   | (1)     |

NOTE (1) Permanent damage to the device may occur if maximum values are exceeded.  
Functional operation should be restricted to the conditions described under Normal Operating Conditions.

(2) Specified values are for a dual lamp (Refer to the Note(1) in the page 10 for further information.).



## 2. OPTICAL CHARACTERISTICS

The following items are measured under stable conditions. The optical characteristics should be measured in a dark room or equivalent state with the methods shown in Note (4).

Measuring equipment : TOPCON BM-5A

\* Ta = 25 ± 2 °C , V<sub>DD</sub> = 5V, fv= 60Hz, fdCLK=32.5MHz, IL = 11.2 mArms

| ITEM                                     | SYMBOL         | CONDITION   | MIN.           | TYP.  | MAX.  | UNIT    | NOTE              |          |
|--|----------------|---|----------------|-------|-------|---------|-------------------|----------|
| Contrast Ratio<br>(Center of screen)     | CR             | φ = 0,<br>θ = 0<br><br>Normal<br>Viewing<br>Angle | -              | 200   | -     |         | (1), (2), (4)     |          |
| Response<br>Time at Ta                   | Rising         |   | T <sub>R</sub> | -     | 20    | -       | msec              | (1), (3) |
|  | Falling        |   | T <sub>F</sub> | -     | 30    | -       |                   |          |
| Luminance of White<br>(Center of screen) | Y <sub>L</sub> |   |                | -     | 200   | -       | cd/m <sup>2</sup> | (1), (4) |
| Color<br>Chromaticity<br>( CIE )         | Red            |   | R <sub>X</sub> | -     | 0.619 | -       |                   | (1), (4) |
|  |                |   | R <sub>Y</sub> | -     | 0.343 | -       |                   |          |
|  | Green          |   | G <sub>X</sub> | -     | 0.298 | -       |                   |          |
|  |                |   | G <sub>Y</sub> | -     | 0.595 | -       |                   |          |
|  | Blue           |   | B <sub>X</sub> | -     | 0.146 | -       |                   |          |
|  |                |   | B <sub>Y</sub> | -     | 0.104 | -       |                   |          |
|  | White          | W <sub>X</sub>                                    | -              | 0.294 | -     |         |                   |          |
|  |                | W <sub>Y</sub>                                    | -              | 0.325 | -     |         |                   |          |
| Viewing<br>Angle                         | Hor.           | θ <sub>L</sub>                                    | 60             | -     | -     | Degrees |                   |          |
|  |                | θ <sub>R</sub>                                    | 60             | -     | -     |         |                   |          |
|  | Ver.           | φ <sub>H</sub>                                    | 55             | -     | -     |         |                   |          |
|  |                | φ <sub>L</sub>                                    | 55             | -     | -     |         |                   |          |

**SAMSUNG**

ELECTRONICS

Note 1) Definition of Viewing Angle : Viewing angle range (5 ± CR )

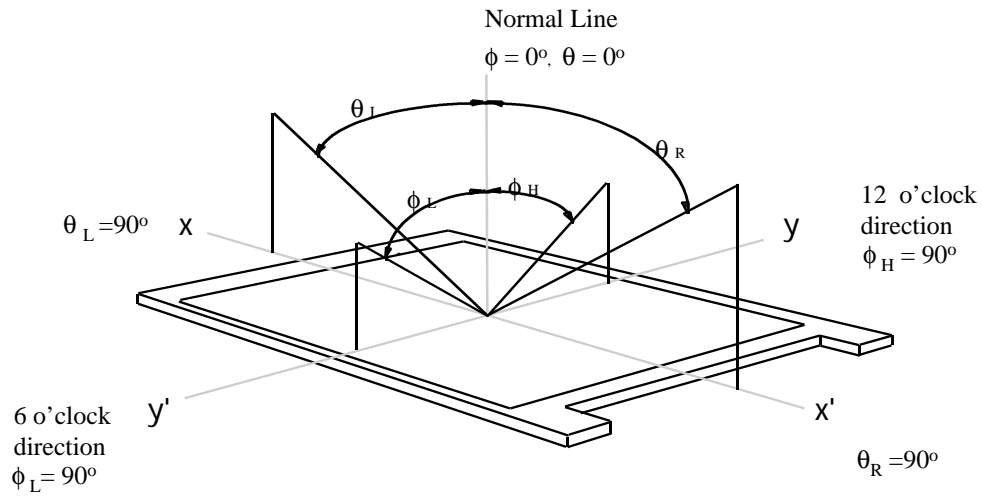

Note 2) Definition of Contrast Ratio (CR) : Ratio of gray max (Gmax) ,gray min (Gmin) at the center point of panel.

$$CR = \frac{\text{Luminance with all pixels white (Gmax)}}{\text{Luminance with all pixels black (Gmin)}}$$

Note 3) Definition of Response time : Sum of  $T_R$  , $T_F$

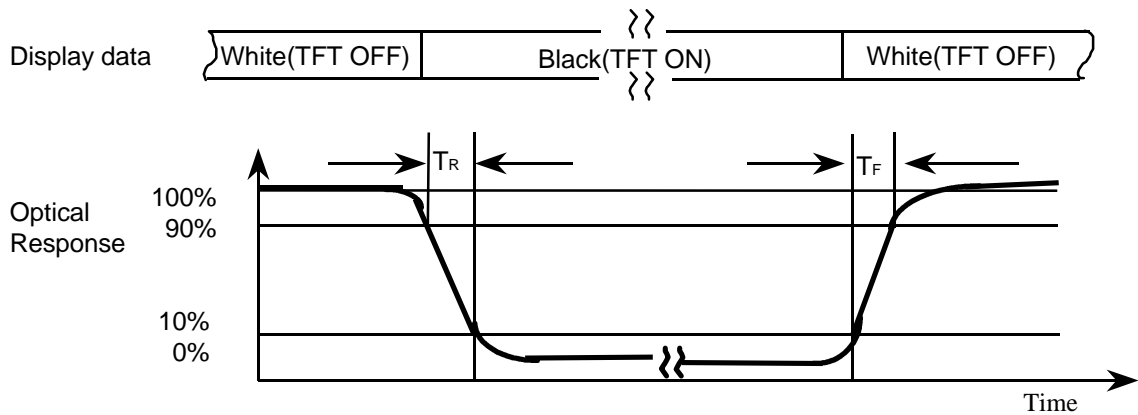

Note 4) After stabilizing and leaving the panel alone at a given temperature for 30 min , the measurement should be executed. Measurement should be executed in a stable, windless, and dark room. 30 min after lighting the back-light. This should be measured in the center of screen.  
Dual lamp current : 11.2mA (5.6mA x 2 ,Refer to the note(1) in the page 10 for further information.)  
Environment condition :  $T_a = 25 \pm 2 \text{ }^\circ\text{C}$

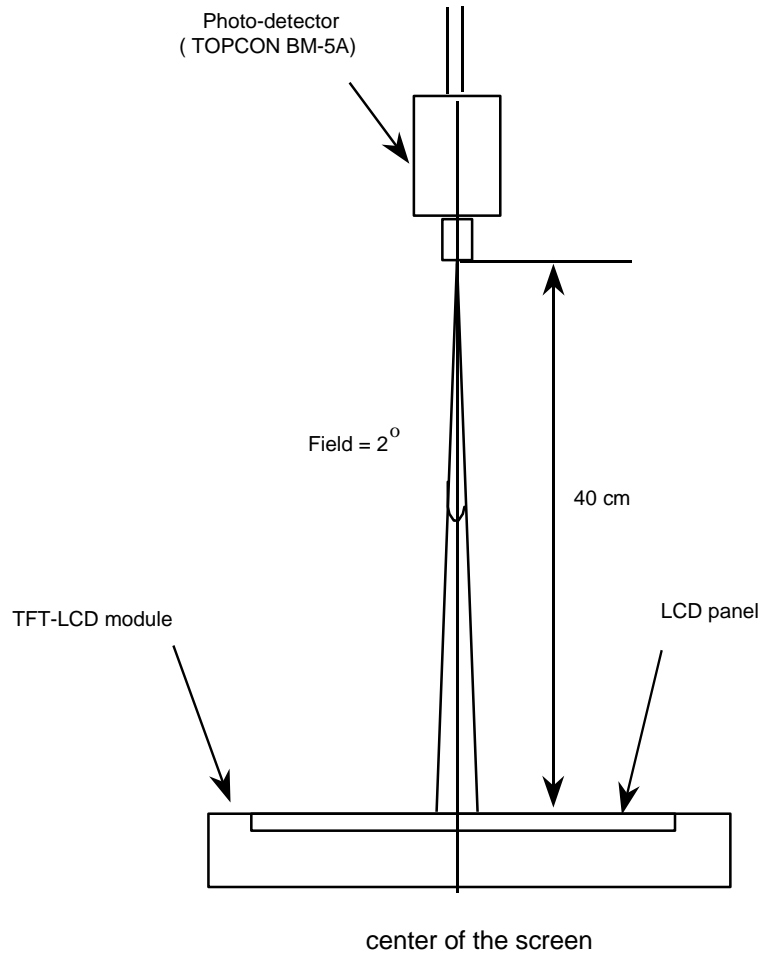

Optical characteristics measurement setup

### 3. ELECTRICAL CHARACTERISTICS

#### 3.1 TFT LCD MODULE

Ta= 25 ± 2 °C

| ITEM                    | SYMBOL            | MIN             | TYP  | MAX  | UNIT            | NOTE |          |
|-------------------------|-------------------|-----------------|------|------|-----------------|------|----------|
| Voltage of Power Supply | V <sub>DD</sub>   | 4.75            | 5.0  | 5.25 | V               |      |          |
| Input Voltage           | High              | V <sub>IH</sub> | 2.64 | -    | V <sub>DD</sub> | (1)  |          |
|                         | Low               | V <sub>IL</sub> | GND  | -    | 0.6             |      |          |
| Current of Power Supply | White             | I <sub>DD</sub> | -    | 360  | -               | mA   | (2)(4)*a |
|                         | Mosaic            |                 | -    | 380  | -               | mA   | (2)(4)*b |
|                         | V.stripe          |                 | -    | 590  | 640             | mA   | (2)(4)*c |
| Vsync Frequency         | f <sub>v</sub>    | -               | 60   | -    | Hz              |      |          |
| Hsync Frequency         | f <sub>H</sub>    | -               | 48.3 | -    | kHz             |      |          |
| Main Frequency          | f <sub>DCLK</sub> | -               | 32.5 | -    | MHz             | (3)  |          |
| Rush Current            | I <sub>rush</sub> | -               | -    | 2.5  | A               | (5)  |          |

Note (1) MCLK , Vsync , Hsync , DE , RA0 ~ RA5 , GA0 ~ GA5 , BA0 ~ BA5 , RB0 ~ RB5 , GB0 ~ GB5 , BB0 ~ BB5

(2) f<sub>v</sub>=60Hz, f<sub>DCLK</sub> =32.5MHZ, V<sub>DD</sub> = 5.0V, DC Current.

(3) 2 Pixels/clock

(4) Power dissipation check pattern

\*a) Black Pattern



Display Brightest Gray Level

Display Darkest Gray Level

\*b) Mosaic Pattern

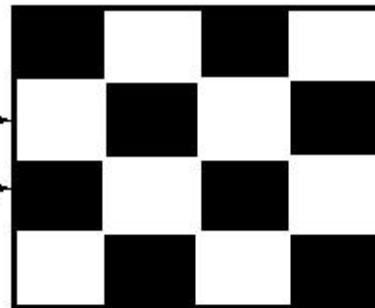



c) Vertical Power Pattern

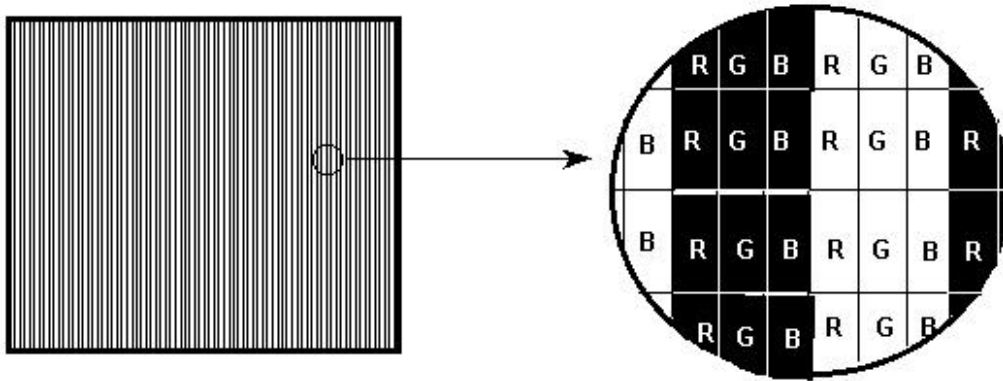

(5) Measurement Conditions

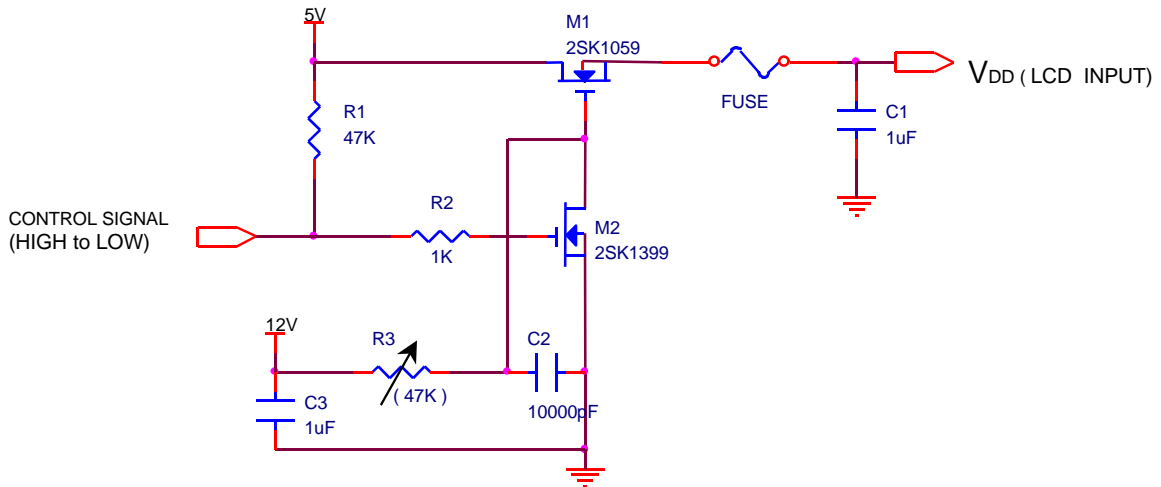

Note : Control Signal : High(+5V) -->Low(Ground)

All Signal lines to panel except for power 5V : Ground

The rising time of supplied voltage is controlled to 470us by R3 and C2 value.

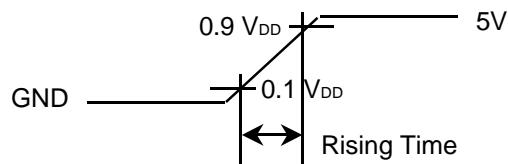

ELECTRONICS

### 3.2 BACK-LIGHT UNIT

The back-light system is an edge-lighting type with 2 dual CCFTs(Cold Cathode Fluorescent Tube). The characters of two dual lamps are shown in the following tables.

Ta= 25 ± 2 °C

| ITEM                | SYMBOL | MIN    | TYP  | MAX         | UNIT              | NOTE |
|---------------------|--------|--------|------|-------------|-------------------|------|
| Lamp Current        | IL     | 4.0    | 11.2 | 11.6        | mA <sub>rms</sub> | (1)  |
| Lamp Voltage        | VL     | -      | 690  | -           | V <sub>rms</sub>  |      |
| Lamp Frequency      | fL     | -      | 55   | -           | kHz               | (2)  |
| Operating Life Time | Hr     | 20,000 | -    | -           | Hour              | (3)  |
| Startup Voltage     | Vs     | -      | -    | 1100 (25°C) | V <sub>rms</sub>  | (4)  |
|                     |        |        |      | 1420 (0°C)  |                   |      |

**Note)** The waveform of the inverter output voltage must be area symmetric and the design of the inverter must have specifications for the modularized lamp.

The performance of the back-light, for example life time or brightness, is much influenced by the characteristics of the DC-AC inverter for the lamp. So all the parameters of an inverter should be carefully designed so as not to produce too much leakage current from high-voltage output of the inverter.

When you design or order the inverter, please make sure that a poor lighting caused by the mismatch of the back-light and the inverter(miss lighting, flicker, etc.) never occur. When you confirm it, the module should be operated in the same condition as it is installed in your instrument.

- Note (1) ✓ Dual lamp current is measured with current meter for high frequency as shown below.  
 ✓ Refer to the block diagram of the back-light unit in the next page for more information.  
 ✓ Specified values are for a dual lamp.

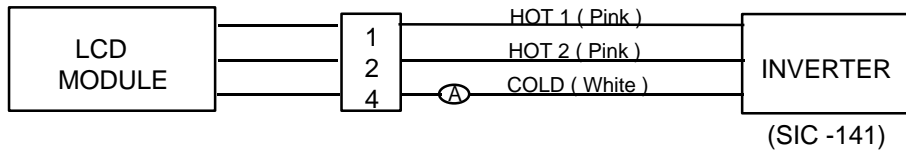

- (2) Lamp frequency may produce interference with horizontal synchronous frequency and this may cause line flow on the display. Therefore lamp frequency shall be detached from the horizontal synchronous frequency and its harmonics as far as possible in order to avoid interference.
- (3) Life time (Hr) of a lamp is defined as the time in which it continues to operate under the condition of Ta = 25 ± 2 °C and IL = 10 mA<sub>rms</sub> until the brightness becomes 50% or lower than it's original value.
- (4) The voltage above this value should be applied to the lamps for more than 1 second to startup. Otherwise the lamps may not to be turned on.



ELECTRONICS

## 4. BLOCK DIAGRAM

### 4.1 TFT LCD MODULE

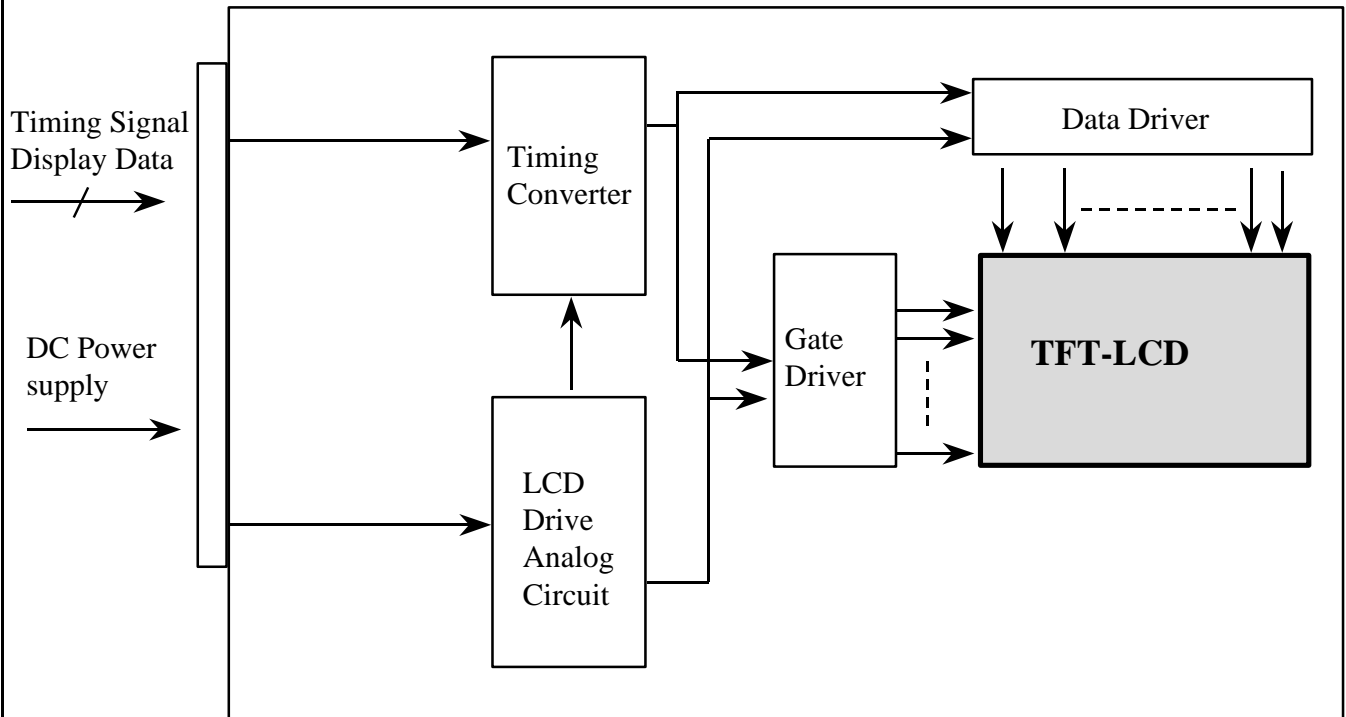

### 4.2 BACK-LIGHT UNIT

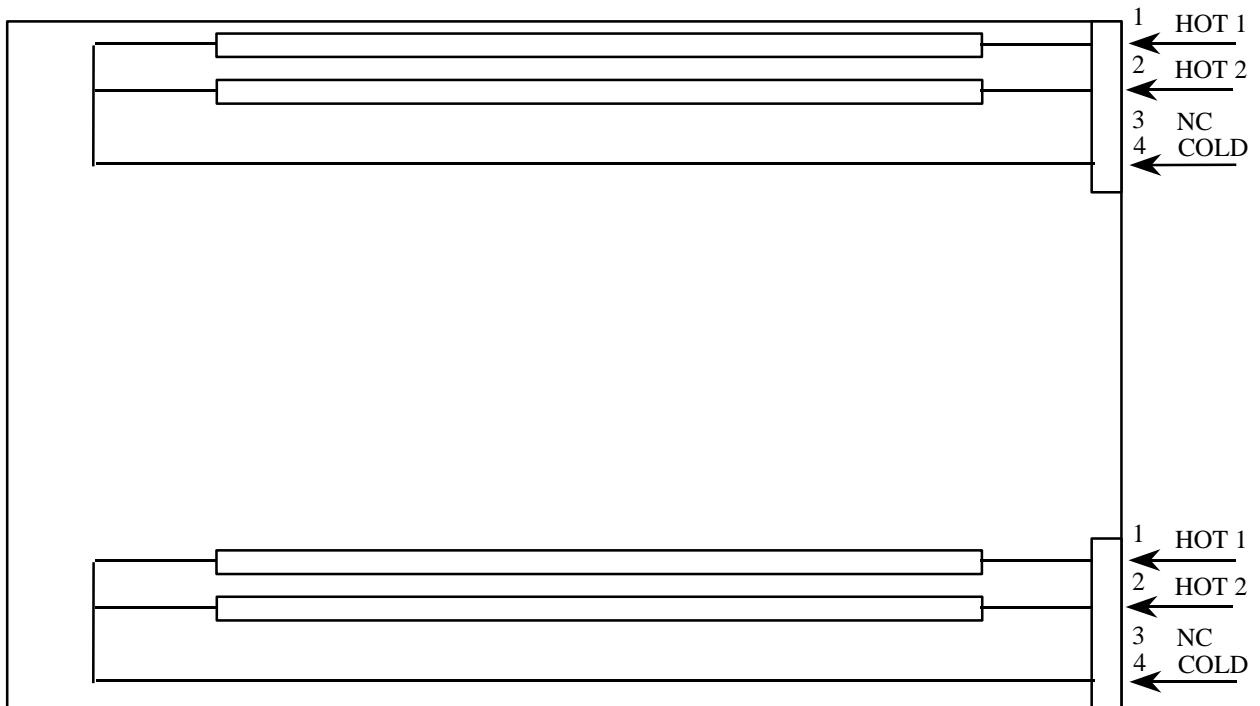

ELECTRONICS

## 5. INPUT TERMINAL PIN ASSIGNMENT

### 5.1. TFT LCD MODULE (Interface Signal & Power)

Connector : Hirose DF14A-30P-1.25H

Matching Socket : Hirose DF14-30S-1.25C

| Pin NO. | Symbol   | Function               | Polarity | Remark |
|---------|----------|------------------------|----------|--------|
| 1       | VDD      | Power Supply [+5.0V]   | -        | -      |
| 2       | VDD      | Power Supply [+5.0V]   | -        | -      |
| 3       | GND      | Ground                 | -        | -      |
| 4       | MCLK     | Data Clock             | -        | (1)    |
| 5       | GND      | Ground                 | -        | -      |
| 6       | VSYNC    | Vertical Sync Signal   | Negative | -      |
| 7       | HSYNC    | Horizontal Sync Signal | Negative | -      |
| 8       | DE       | Data Enable            | Positive | -      |
| 9       | GND      | Ground                 | -        | -      |
| 10      | RA0(ODD) | Red Data [LSB] - ODD   | Positive | -      |
| 11      | RA1      | Red Data               | Positive | -      |
| 12      | RA2      | Red Data               | Positive | -      |
| 13      | RA3      | Red Data               | Positive | -      |
| 14      | RA4      | Red Data               | Positive | -      |
| 15      | RA5      | Red Data [MSB] -ODD    | Positive | -      |
| 16      | GND      | Ground                 | -        | -      |
| 17      | GA0(ODD) | Green Data [LSB] - ODD | Positive | -      |
| 18      | GA1      | Green Data             | Positive | -      |
| 19      | GA2      | Green Data             | Positive | -      |
| 20      | GA3      | Green Data             | Positive | -      |
| 21      | GA4      | Green Data             | Positive | -      |
| 22      | GA5      | Green Data [MSB] -ODD  | Positive | -      |
| 23      | GND      | Ground                 | -        | -      |
| 24      | BA0(ODD) | Blue Data [LSB] -ODD   | Positive | -      |
| 25      | BA1      | Blue Data              | Positive | -      |
| 26      | BA2      | Blue Data              | Positive | -      |
| 27      | BA3      | Blue Data              | Positive | -      |
| 28      | BA4      | Blue Data              | Positive | -      |
| 29      | BA5      | Blue Data [MSB] -ODD   | Positive | -      |
| 30      | GND      | Ground                 | -        | -      |



ELECTRONICS

Connector : Hirose DF14A-25P-1.25H

Matching Socket : Hirose DF14-25S-1.25C

| Pin NO. | Symbol    | Function               | Polarity | Remark |
|---------|-----------|------------------------|----------|--------|
| 1       | GND       | Ground                 | -        | -      |
| 2       | RB0(EVEN) | Red Data [LSB] -EVEN   | Positive | -      |
| 3       | RB1       | Red Data               | Positive | -      |
| 4       | RB2       | Red Data               | Positive | -      |
| 5       | NC(GND)   | No Connection          | -        | -      |
| 6       | RB3       | Red Data               | Positive | -      |
| 7       | RB4       | Red Data               | Positive | -      |
| 8       | RB5       | Red Data [MSB] -EVEN   | Positive | -      |
| 9       | GND       | Ground                 | -        | -      |
| 10      | GB0(EVEN) | Green Data [LSB] -EVEN | Positive | -      |
| 11      | GB1       | Green Data             | Positive | -      |
| 12      | GB2       | Green Data             | Positive | -      |
| 13      | NC(GND)   | No Connection          | -        | -      |
| 14      | GB3       | Green Data             | Positive | -      |
| 15      | GB4       | Green Data             | Positive | -      |
| 16      | GB5       | Green Data [MSB] -EVEN | Positive | -      |
| 17      | GND       | Ground                 | -        | -      |
| 18      | BB0(EVEN) | Blue Data [LSB] -EVEN  | Positive | -      |
| 19      | BB1       | Blue Data              | Positive | -      |
| 20      | BB2       | Blue Data              | Positive | -      |
| 21      | NC        | No Connection          | -        | -      |
| 22      | BB3       | Blue Data              | Positive | -      |
| 23      | BB4       | Blue Data              | Positive | -      |
| 24      | BB5       | Blue Data [MSB] -EVEN  | Positive | -      |
| 25      | GND       | Ground                 | -        | -      |

**Note** (1) Display data is sampled at the falling edge of data clock.

## 5.2 BACK-LIGHT UNIT

| PIN No.            | INPUT [ ch1 ] , [ ch2 ] | Color | Function      |
|--------------------|-------------------------|-------|---------------|
| 1                  | HOT 1                   | Pink  | High Voltage  |
| 2                  | HOT 2                   | Pink  | High Voltage  |
| 3                  | N.C                     | -     | No Connection |
| 4                  | COLD                    | White | Ground        |
| Connector Part No. | JST BHR-04VS-1          |       |               |



ELECTRONICS

### 5.3 Input Signal, Basic Display Colors and Gray Scale of Each Colors

| COLOR               | DISPLAY | DATA SIGNAL |    |    |    |    |       |    |    |    |    |      |    |    |    |    |    | GRAY SCALE LEVEL |        |
|---------------------|---------|-------------|----|----|----|----|-------|----|----|----|----|------|----|----|----|----|----|------------------|--------|
|                     |         | RED         |    |    |    |    | GREEN |    |    |    |    | BLUE |    |    |    |    |    |                  |        |
|                     |         | R0          | R1 | R2 | R3 | R4 | R5    | G0 | G1 | G2 | G3 | G4   | G5 | B0 | B1 | B2 | B3 |                  | B4     |
| BASIC COLOR         | BLACK   | 0           | 0  | 0  | 0  | 0  | 0     | 0  | 0  | 0  | 0  | 0    | 0  | 0  | 0  | 0  | 0  | 0                | -      |
|                     | BLUE    | 0           | 0  | 0  | 0  | 0  | 0     | 0  | 0  | 0  | 0  | 0    | 1  | 1  | 1  | 1  | 1  | 1                | -      |
|                     | GREEN   | 0           | 0  | 0  | 0  | 0  | 0     | 1  | 1  | 1  | 1  | 1    | 1  | 0  | 0  | 0  | 0  | 0                | -      |
|                     | CYAN    | 0           | 0  | 0  | 0  | 0  | 0     | 1  | 1  | 1  | 1  | 1    | 1  | 1  | 1  | 1  | 1  | 1                | -      |
|                     | RED     | 1           | 1  | 1  | 1  | 1  | 1     | 0  | 0  | 0  | 0  | 0    | 0  | 0  | 0  | 0  | 0  | 0                | -      |
|                     | MAGENTA | 1           | 1  | 1  | 1  | 1  | 1     | 0  | 0  | 0  | 0  | 0    | 0  | 1  | 1  | 1  | 1  | 1                | -      |
|                     | YELLOW  | 1           | 1  | 1  | 1  | 1  | 1     | 1  | 1  | 1  | 1  | 1    | 1  | 0  | 0  | 0  | 0  | 0                | -      |
|                     | WHITE   | 1           | 1  | 1  | 1  | 1  | 1     | 1  | 1  | 1  | 1  | 1    | 1  | 1  | 1  | 1  | 1  | 1                | -      |
| GRAY SCALE OF RED   | BLACK   | 0           | 0  | 0  | 0  | 0  | 0     | 0  | 0  | 0  | 0  | 0    | 0  | 0  | 0  | 0  | 0  | 0                | R0     |
|                     | DARK ↑  | 1           | 0  | 0  | 0  | 0  | 0     | 0  | 0  | 0  | 0  | 0    | 0  | 0  | 0  | 0  | 0  | 0                | R1     |
|                     |         | 0           | 1  | 0  | 0  | 0  | 0     | 0  | 0  | 0  | 0  | 0    | 0  | 0  | 0  | 0  | 0  | 0                | R2     |
|                     |         | :           | :  | :  | :  | :  | :     | :  | :  | :  | :  | :    | :  | :  | :  | :  | :  | :                | R3~R60 |
|                     |         | :           | :  | :  | :  | :  | :     | :  | :  | :  | :  | :    | :  | :  | :  | :  | :  | :                |        |
|                     | ↓ LIGHT | 1           | 0  | 1  | 1  | 1  | 1     | 0  | 0  | 0  | 0  | 0    | 0  | 0  | 0  | 0  | 0  | 0                | R61    |
|                     |         | 0           | 1  | 1  | 1  | 1  | 1     | 0  | 0  | 0  | 0  | 0    | 0  | 0  | 0  | 0  | 0  | 0                | R62    |
|                     | RED     | 1           | 1  | 1  | 1  | 1  | 1     | 0  | 0  | 0  | 0  | 0    | 0  | 0  | 0  | 0  | 0  | 0                | R63    |
| GRAY SCALE OF GREEN | BLACK   | 0           | 0  | 0  | 0  | 0  | 0     | 0  | 0  | 0  | 0  | 0    | 0  | 0  | 0  | 0  | 0  | 0                | G0     |
|                     | DARK ↑  | 0           | 0  | 0  | 0  | 0  | 0     | 1  | 0  | 0  | 0  | 0    | 0  | 0  | 0  | 0  | 0  | 0                | G1     |
|                     |         | 0           | 0  | 0  | 0  | 0  | 0     | 0  | 1  | 0  | 0  | 0    | 0  | 0  | 0  | 0  | 0  | 0                | G2     |
|                     |         | :           | :  | :  | :  | :  | :     | :  | :  | :  | :  | :    | :  | :  | :  | :  | :  | :                | G3~G60 |
|                     |         | :           | :  | :  | :  | :  | :     | :  | :  | :  | :  | :    | :  | :  | :  | :  | :  | :                |        |
|                     | ↓ LIGHT | 0           | 0  | 0  | 0  | 0  | 0     | 1  | 0  | 1  | 1  | 1    | 1  | 0  | 0  | 0  | 0  | 0                | G61    |
|                     |         | 0           | 0  | 0  | 0  | 0  | 0     | 0  | 1  | 1  | 1  | 1    | 1  | 0  | 0  | 0  | 0  | 0                | G62    |
|                     | GREEN   | 0           | 0  | 0  | 0  | 0  | 0     | 1  | 1  | 1  | 1  | 1    | 1  | 0  | 0  | 0  | 0  | 0                | G63    |
| GRAY SCALE OF BLUE  | BLACK   | 0           | 0  | 0  | 0  | 0  | 0     | 0  | 0  | 0  | 0  | 0    | 0  | 0  | 0  | 0  | 0  | 0                | B0     |
|                     | DARK ↑  | 0           | 0  | 0  | 0  | 0  | 0     | 0  | 0  | 0  | 0  | 0    | 0  | 1  | 0  | 0  | 0  | 0                | B1     |
|                     |         | 0           | 0  | 0  | 0  | 0  | 0     | 0  | 0  | 0  | 0  | 0    | 0  | 0  | 1  | 0  | 0  | 0                | B2     |
|                     |         | :           | :  | :  | :  | :  | :     | :  | :  | :  | :  | :    | :  | :  | :  | :  | :  | :                | B3~B60 |
|                     |         | :           | :  | :  | :  | :  | :     | :  | :  | :  | :  | :    | :  | :  | :  | :  | :  | :                |        |
|                     | ↓ LIGHT | 0           | 0  | 0  | 0  | 0  | 0     | 0  | 0  | 0  | 0  | 0    | 0  | 0  | 1  | 0  | 1  | 1                | B61    |
|                     |         | 0           | 0  | 0  | 0  | 0  | 0     | 0  | 0  | 0  | 0  | 0    | 0  | 0  | 1  | 1  | 1  | 1                | B62    |
|                     | BLUE    | 0           | 0  | 0  | 0  | 0  | 0     | 0  | 0  | 0  | 0  | 0    | 0  | 1  | 1  | 1  | 1  | 1                | B63    |

Note) ✓ Definition of Gray :

Rn : Red Gray, Gn : Green Gray, Bn : Blue Gray (n = Gray level)

✓ Input Signal : 0 = Low level voltage, 1 = High level voltage



## 6. INTERFACE TIMING

### 6.1 Timing Parameters ( SYNC&DE Mode )

| Signal            | Item           | Symbol             | MIN | TYP        | MAX | Unit         | Note |
|-------------------|----------------|--------------------|-----|------------|-----|--------------|------|
| Clock             | Frequency      | 1 / T <sub>c</sub> | -   | 32.5       | -   | MHz          |      |
|                   | High Time      | T <sub>CH</sub>    | 4   | -          | -   | nsec         |      |
|                   | Low Time       | T <sub>CL</sub>    | 4   | -          | -   | nsec         |      |
| Data              | Setup Time     | T <sub>DS</sub>    | 4   | -          | -   | nsec         |      |
|                   | Hold Time      | T <sub>DH</sub>    | 4   | -          | -   | nsec         |      |
| Data Enable       | Setup Time     | T <sub>ES</sub>    | 4   | -          | -   | nsec         | (1)  |
| Horizontal Sync   | Cycle          | T <sub>H</sub>     | -   | 20.68      | -   | usec         |      |
|                   |                |                    | -   | 672        | -   | clocks       |      |
|                   | Pulse Width    | T <sub>HP</sub>    | -   | 68         | -   | clocks       |      |
| Vertical Sync     | Cycle          | T <sub>V</sub>     | 772 | 16.7   806 | -   | msec   lines |      |
|                   | Pulse Width    | T <sub>VP</sub>    | 1   | -          | 35  | lines        |      |
| Horizontal Signal | Display Start  | T <sub>HS</sub>    | 148 | 148        | 148 | clocks       |      |
|                   | Display period | T <sub>HD</sub>    | 512 | 512        | 512 | clocks       |      |
| Vertical Signal   | Display Start  | T <sub>VS</sub>    | -   | 35         | -   | lines        |      |
|                   | Display Period | T <sub>VD</sub>    | 768 | 768        | 768 | lines        |      |

- Note (1) ✓ The duration of DE [DTMG] signal must be longer than 1 clock period at every horizontal sync. Period  
 ✓ In case DE is fixed "Low", Panel operates by Sync only mode.  
 In this case, DE signal shouldn't be kept "High" during operation.

## 6.2 Timing diagrams of interface signal (SYNC&DE mode)

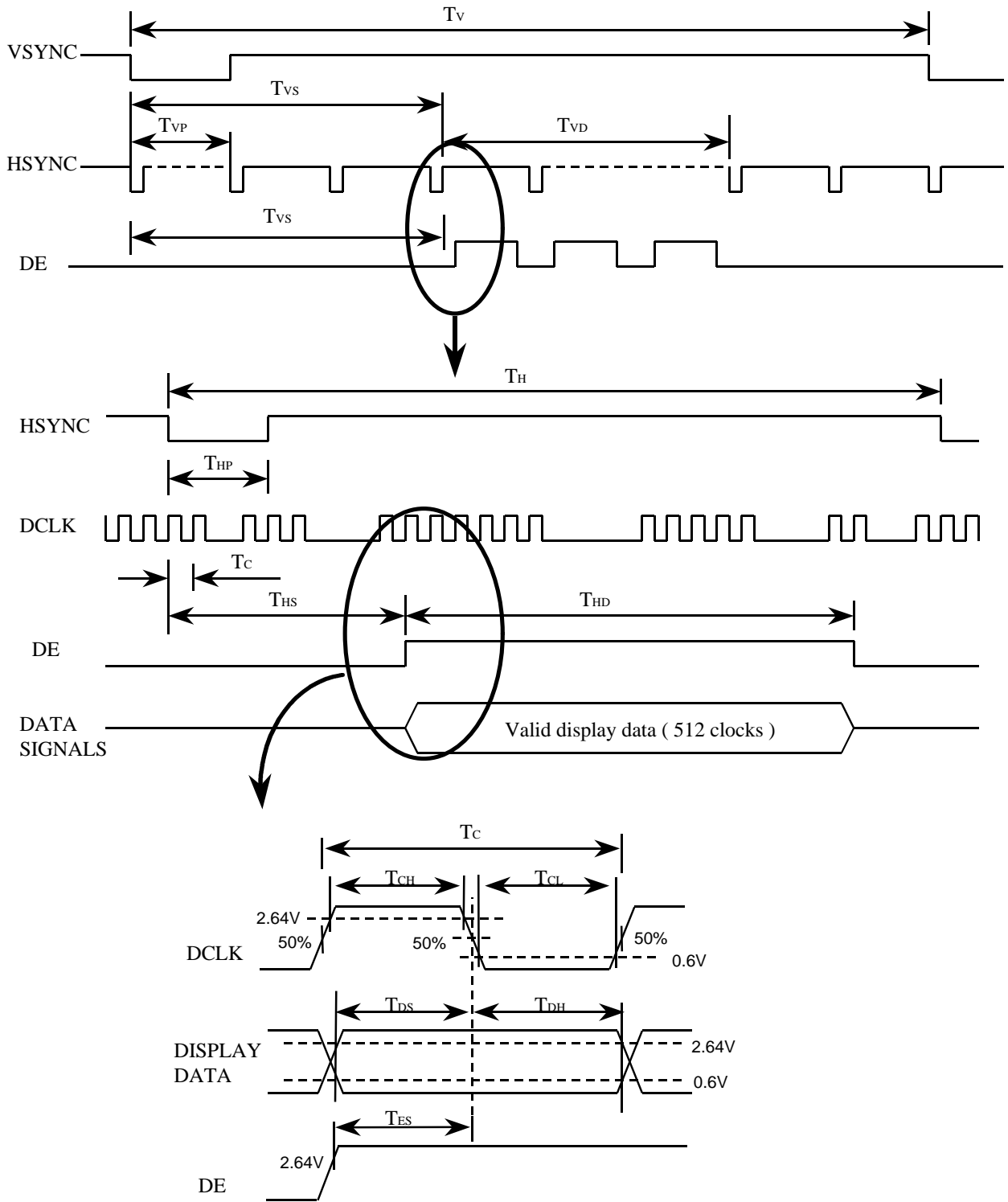



### 6.3 Timing Parameters ( DE only mode )

| Signal                         | Item           | Symbol    | MIN | TYP        | MAX | Unit         | Note |
|--------------------------------|----------------|-----------|-----|------------|-----|--------------|------|
| Clock                          | Frequency      | $1 / T_c$ | -   | 32.5       | -   | MHz          |      |
|                                | High Time      | $T_{CH}$  | 4   | -          | -   | nsec         |      |
|                                | Low Time       | $T_{CL}$  | 4   | -          | -   | nsec         |      |
| Data                           | Setup Time     | $T_{DS}$  | 4   | -          | -   | nsec         |      |
|                                | Hold Time      | $T_{DH}$  | 4   | -          | -   | nsec         |      |
| Data Enable                    | Setup Time     | $T_{ES}$  | 4   | -          | -   | nsec         | (1)  |
| Frame Frequency                | Cycle          | $T_V$     | 772 | 16.7   806 | -   | msec   lines |      |
| Vertical Active Display Term   | Display Period | $T_{VD}$  | 768 | 768        | 768 | lines        |      |
| One Line Scanning Time         | Cycle          | $T_H$     | -   | 672        | -   | clocks       |      |
| Horizontal Active Display Term | Display Period | $T_{HD}$  | 512 | 512        | 512 | clocks       |      |

**Note (1) When LT150X1-151 model is operated by DE only mode, Hsync and Vsync input signals should be fixed to “Low” for stable operation. Otherwise, the module could operate abnormally.**



### 6.4 Timing diagrams of interface signal ( DE only mode )

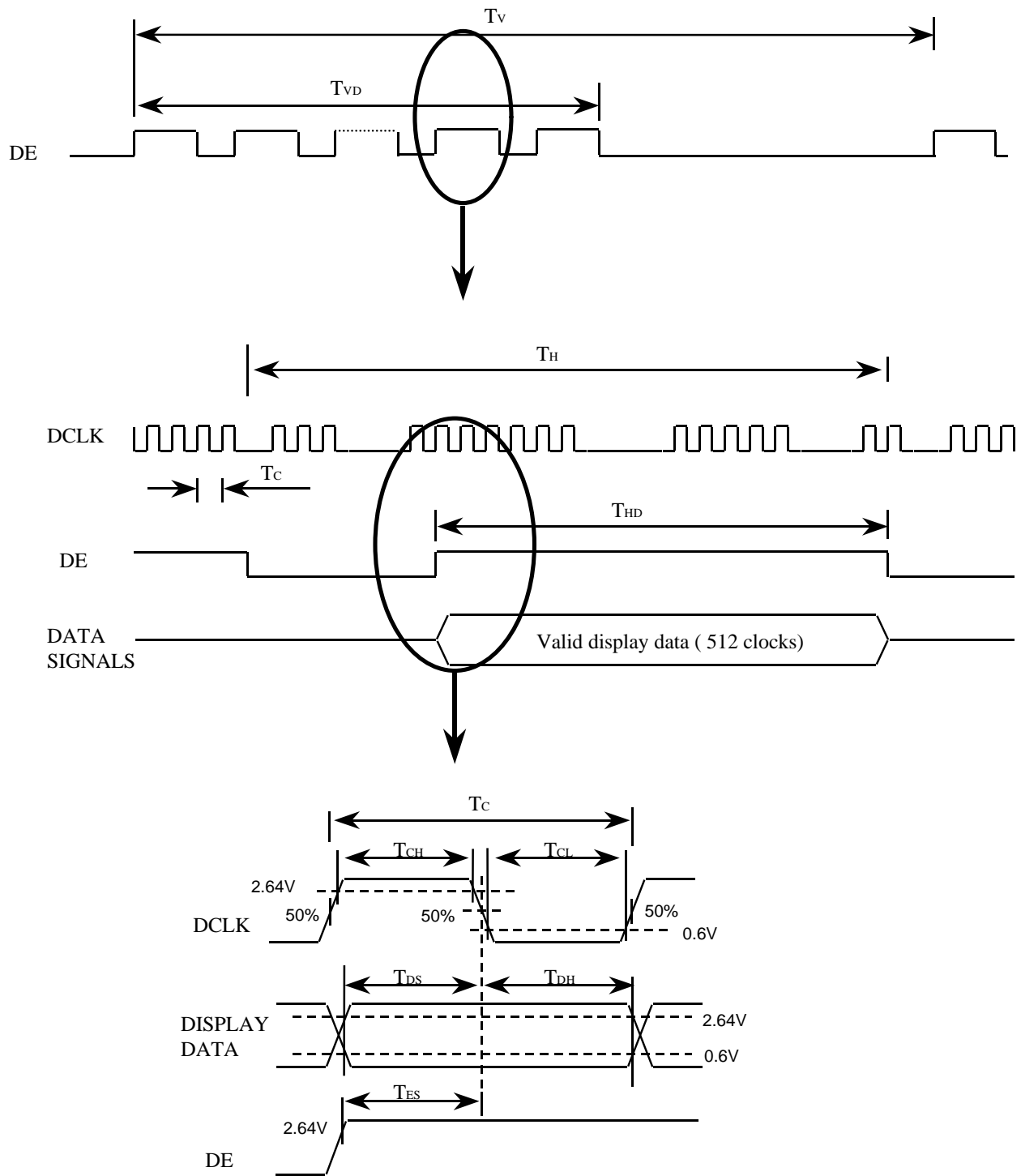

## 6.5 Power ON/OFF Sequence

: To prevent a latch-up or DC operation of the LCD module, the power on/off sequence should be as the diagram below.

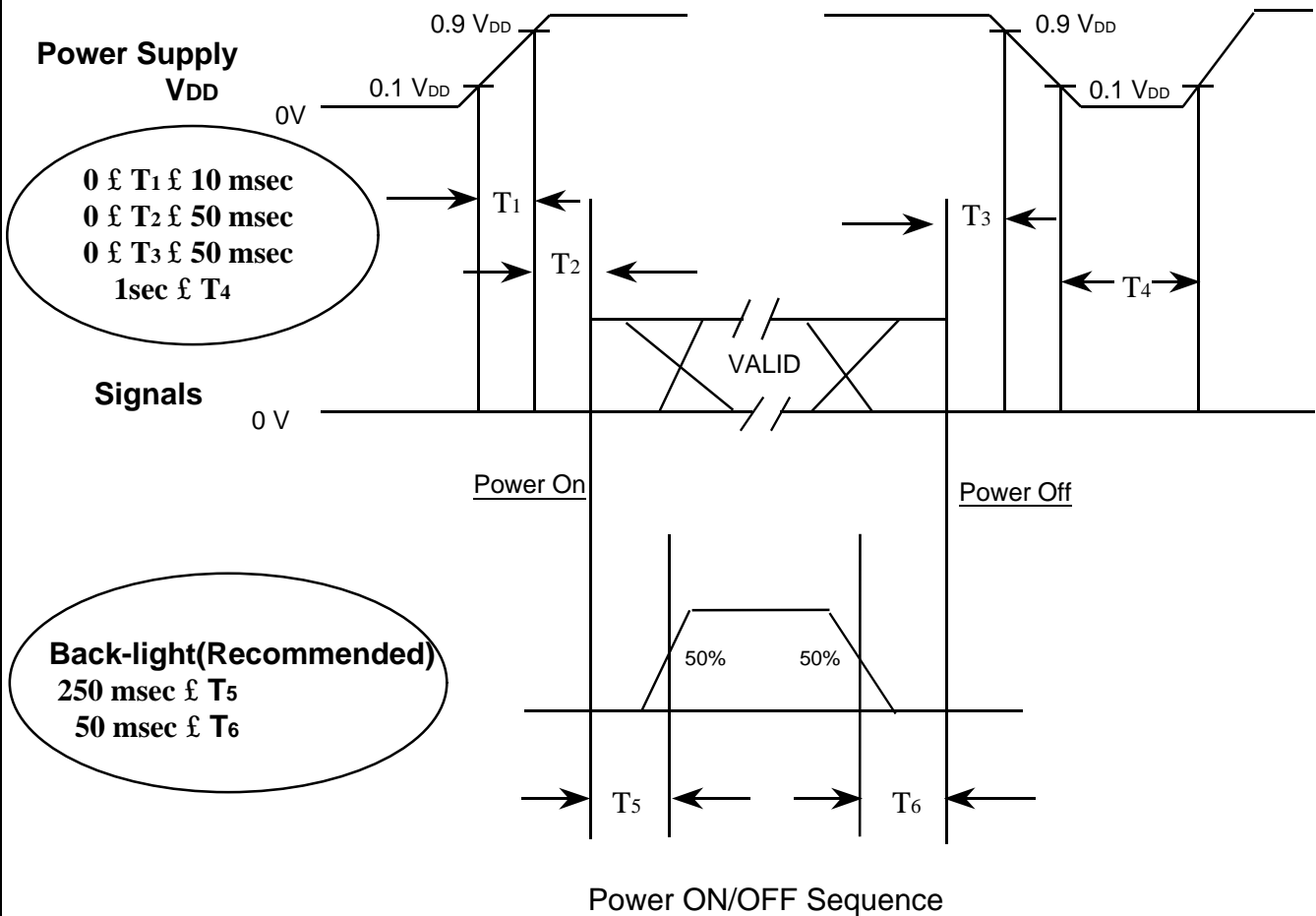

Power ON/OFF Sequence

### NOTE.

- (1) The supply voltage of the external system for the module input should be the same as the definition of V<sub>DD</sub>.
- (2) Apply the lamp voltage within the LCD operation range. When the back-light turns on before the LCD operation or the LCD turns off before the back-light turns off, the display may momentarily become white.
- (3) In case of V<sub>DD</sub> = off level, please keep the level of input signals on the low or keep a high impedance.
- (4) T<sub>4</sub> should be measured after the module has been fully discharged between power off and on period.
- (5) Interface signal shall not be kept at high impedance when the power is on.



## 8. GENERAL PRECAUTIONS

### 8.1 Handling

- (a) When the module is assembled, It should be attached to the system firmly using every mounting holes. Be careful not to twist and bend the modules.
- (b) Refrain from strong mechanical shock and / or any force to the module. In addition to damage, this may cause improper operation or damage to the module and CCFT back-light.
- (c) Note that polarizers are very fragile and could be easily damaged. Do not press or scratch the surface harder than a HB pencil lead.
- (d) Wipe off water droplets or oil immediately. If you leave the droplets for a long time, Staining and discoloration may occur.
- (e) If the surface of the polarizer is dirty, clean it using some absorbent cotton or soft cloth.
- (f) The desirable cleaners are water, IPA(Isopropyl Alcohol) or Hexane.  
Do not use Ketone type materials(ex. Acetone), Ethyl alcohol, Toluene, Ethyl acid or Methyl chloride. It might permanent damage to the polarizer due to chemical reaction.
- (g) If the liquid crystal material leaks from the panel, it should be kept away from the eyes or mouth . In case of contact with hands, legs or clothes, it must be washed away thoroughly with soap.
- (h) Protect the module from static , it may cause damage to the CMOS Gate Array IC.
- (i) Use finger-stalls with soft gloves in order to keep display clean during the incoming inspection and assembly process.
- (j) Do not disassemble the module.
- (k) Do not pull or fold the lamp wire.
- (l) Do not adjust the variable resistor which is located on the back side.
- (m) Pins of I/F connector shall not be touched directly with bare hands.

## 8.2 Storage

- (a) Do not leave the module in high temperature, and high humidity for a long time. It is highly recommended to store the module with temperature from 0 to 35 °C and relative humidity of less than 70%.
- (b) Do not store the TFT-LCD module in direct sunlight.
- (c) The module shall be stored in a dark place. It is prohibited to apply sunlight or fluorescent light during the store.

## 8.3 Operation

- (a) Do not connect,disconnect the module in the “ Power On” condition.
- (b) Power supply should always be turned on/off by the item 6.5 “ Power on/off sequence “.
- (c) Module has high frequency circuits. Sufficient suppression to the electromagnetic interference shall be done by system manufacturers. Grounding and shielding methods may be important to minimize the interference.
- (d) The cable between the back-light connector and its inverter power supply shall be a minimized length and be connected directly . The longer cable between the back-light and the inverter may cause lower luminance of lamp(CCFT) and may require higher startup voltage(Vs).

## 8.4 Others

- (a) Ultra-violet ray filter is necessary for outdoor operation.
- (b) Avoid condensation of water. It may result in improper operation or disconnection of electrode.
- (c) Do not exceed the absolute maximum rating value. ( the supply voltage variation, input voltage variation, variation in part contents and environmental temperature, so on) Otherwise the module may be damaged.
- (d) If the module displays the same pattern continuously for a long period of time,it can be the situation when the image “sticks” to the screen.
- (e) This module has its circuitry PCB's on the rear side and should be handled carefully in order not to be stressed.