

Full Color Dot Matrix LED Unit for Indoor Use LT1550W(Chip Type)

(Under development)

■ Features

- No. of dots : 16X32dots
- Outline dimensions : 64X128mm
- Dot size : 3.0X3.0mm
- Dot pitch : 4.0mm
- Radiation color : Blue+Yellow-green+Red(Full color)
- Driving method : 1/16 duty dynamic drive

■ Absolute Maximum Ratings

(Ta=25°C)

Parameter	Symbol	Rating	Unit
Supply voltage for IC	VCC	-0.3 to +5.5	V
Supply voltage for LED	VLED	-0.3 to (+6.5)	V
Input voltage	VI	-0.3 to VCC+0.3	V
Turn-on time	ton	1	ms
Operating temperature	Topr	-10 to +60	°C
Storage temperature	Tstg	-20 to +70	°C
Power dissipation	P	62	W

■ Optical Characteristics

(Ta=25°C, VCC=5V, V(R, G)=5V, V(B)=8V)

Parameter	Symbol	TYP.	Unit
Luminance	Red	(100)	cd/m ²
	Yellow-green	(150)	
	Blue	(70)	
Peak emission wavelength	Red	635	nm
	Yellow-green	565	
	Blue	430	
Spectrum radiation bandwidth	Red	35	nm
	Yellow-green	30	
	Blue	65	

■ Terminal Functions

Connector	Symbol	Function
Power supply (CN1)	V(R,G)	Supply voltage for LED(Red, Yellow-green)+5V
	V(B)	Supply voltage for LED(Blue)+(+8V±10%)
	VCC	Supply voltage for IC+5V
	GND	Ground
Input signal (CN2)	A0 to A3	Address specification signal for row driver
	RDATA GDATA BDATA	Serial data input for each color(H:ON, L:OFF)
	LATCH	Latch signal of display data(H: Serial data is converted to parallel data.L: Contents are latched.)
	RENABLE GENABLE BENABLE	Controls ON/OFF of each color of LED (H: LED OFF)
	CLOCK	Clock signal for data transmission in the shift-register.(L→H: serial data is shifted.)
Output signal (CN3)	GND	Ground for signal
	A0 to A3	Buffered input signal
	RDATA GDATA BDATA	Input signal generated through 32-bit shift register
	LATCH	Buffered input signal
	RENABLE GENABLE BENABLE	Buffered input signal
Output signal (CN3)	CLOCK	Buffered input signal
	GND	Ground for signal

Each signal is used as input signal for next unit.

* As for the terminal number, refer to the outline dimensions.

■ Electrical Characteristics

(Ta=25°C, VCC=5V, V(R, G)=5V, V(B)=8V)

Parameter	Symbol	MIN	TYP	MAX	Unit
Supply voltage for IC	VCC	4.75	5.0	5.25	V
Supply voltage for LED	VLED	(5.75)	(6.0)	(6.25)	
IC current dissipation	ICC	—	200	260	mA
Input voltage	VIH	3.5	—	—	V
	VIL	—	—	1.5	V
Input current	I _{IH} ^{*3}	—	—	0.1	μA
	I _{IL} ^{*4}	—	—	0.12	mA
Clock frequency	fCLK	—	—	10	MHz
Frame frequency	fFR	70	250	1000	Hz

*1 Red, *2 Yellow-green, Blue, *3 VIH=5, *4 VIL=0V

■ Timing Chart

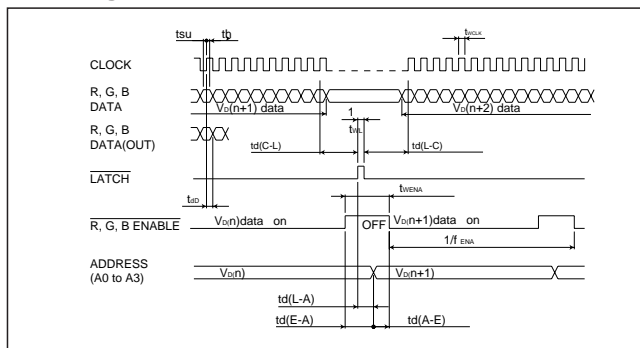

■ Block Diagram

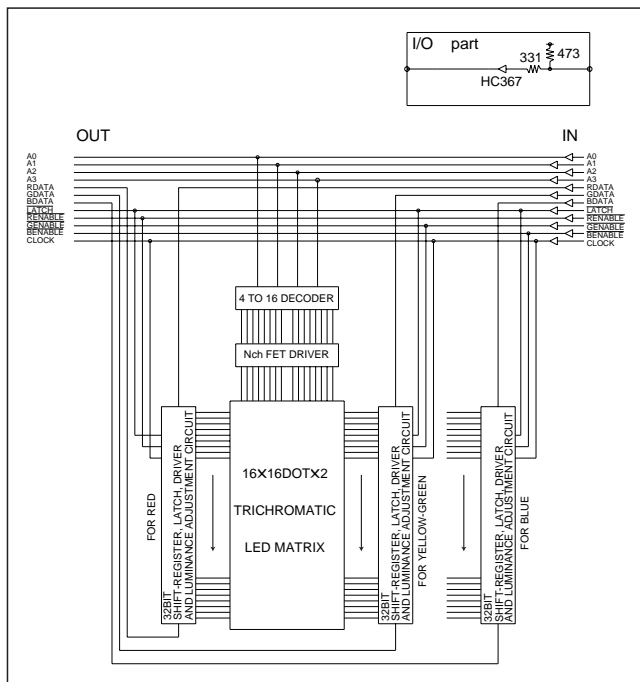

15

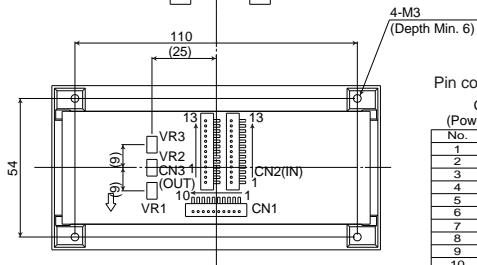
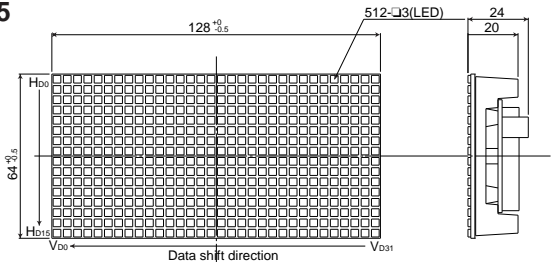

Pin connection

CN1

(Power supply)

No.	Name
1	V(B)
2	V(B)
3	V(R,G)
4	V(R,G)
5	VCC
6	GND
7	GND
8	GND
9	GND
10	GND

CN2
(Input signal)CN3
(Output signal)

No.	Name	No.	Name
1	A0	1	A0
2	A1	2	A1
3	A2	3	A2
4	A3	4	A3
5	RDATA	5	RDATA
6	GDATA	6	GDATA
7	BDATA	7	BDATA
8	LATCH	8	LATCH
9	RENABLE	9	RENABL
10	GENABLE	10	GENABL
11	BENABLE	11	BENABL
12	CLOCK	12	CLOCK
13	GND	13	GND