

Low Noise Bias Generator in 2mm × 2mm DFN

FEATURES

- Generates Low Noise Bias Voltage from Single Cell Li-Ion Battery
- Output Current: Up to 40mA
- Low Output Ripple and Noise: <math><500\mu\text{V}_{\text{P-P}}</math>
- Boost Regulator
 - 1MHz Operation (LT3048)
 - 2.2MHz Operation (LT3048-XX)
 - Integrated Schottky Diode
- Low Dropout Linear Regulator
 - 1.235V Feedback Voltage (LT3048)
 - Low Noise: <math><120\mu\text{V}_{\text{RMS}}</math> (10Hz to 100kHz)
 - 0.1% Load Regulation
- Fixed 3.3V, 5V, 12V, 15V and Adjustable Output Options
- Short-Circuit and Thermal Protection
- Load Disconnect in Shutdown
- Available in 2mm × 2mm DFN Package

APPLICATIONS

- Sensor Bias
- Op Amp Supply

DESCRIPTION

The LT[®]3048 series generate low noise, low ripple bias supplies from input voltages of 2.7V to 4.8V.

The LT3048 includes a boost regulator and a LDO linear regulator. The boost regulator provides power to the linear regulator.

The boost regulator output voltage is regulated to 1.1V above the LDO output, optimizing LDO ripple rejection and transient response. Fixed frequency operation and current mode control allow the use of very small inductors and results in low, predictable output ripple.

The linear regulator in the LT3048 generates a programmable output and the LT3048-XX generate fixed output voltages. High power supply ripple rejection combined with a low noise internal reference results in less than 500 $\mu\text{V}_{\text{P-P}}$ output ripple and noise.

The LT3048 is available in a 8-lead 2mm × 2mm DFN package.

All registered trademarks and trademarks are the property of their respective owners.

TYPICAL APPLICATION

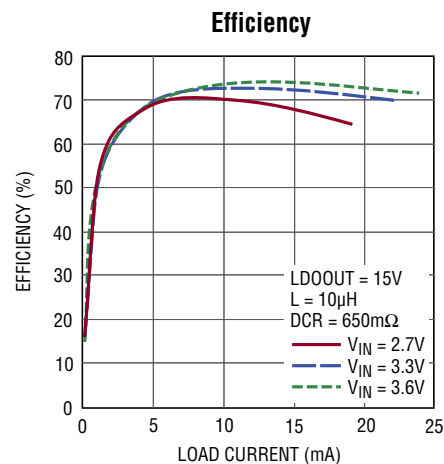
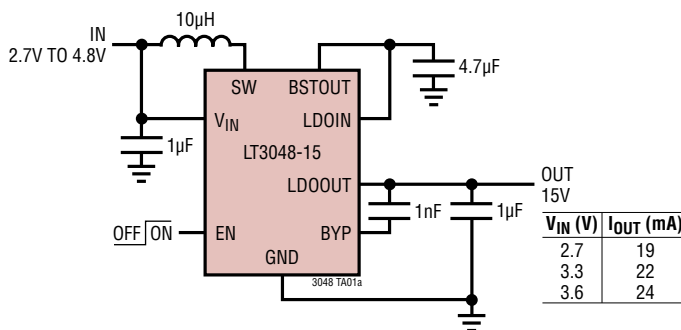

LT3048 Series

ABSOLUTE MAXIMUM RATINGS

(Note 1)

V_{IN}	6V
SW	25V
BSTOUT	23V
LDOIN	22V
LDOOUT	22V
FB	6V
BYP	$\pm 0.3V$
EN	6V

Operating Junction Temperature Range (Note 2)

E-Grade	$-40^{\circ}C$ to $125^{\circ}C$
I-Grade	$-40^{\circ}C$ to $125^{\circ}C$
Maximum Junction Temperature	$125^{\circ}C$
Storage Temperature Range	$-65^{\circ}C$ to $150^{\circ}C$

PIN CONFIGURATION

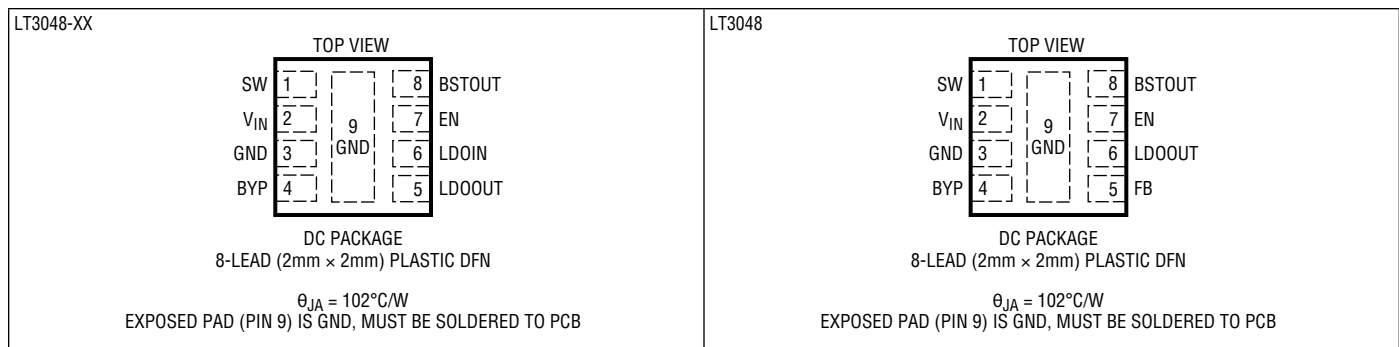

ORDER INFORMATION

LEAD FREE FINISH	TAPE AND REEL	PART MARKING	PACKAGE DESCRIPTION	TEMPERATURE RANGE
LT3048EDC#PBF	LT3048EDC#TRPBF	LGRR	8-Lead (2mm × 2mm) Plastic DFN	$-40^{\circ}C$ to $125^{\circ}C$
LT3048IDC#PBF	LT3048IDC#TRPBF	LGRR	8-Lead (2mm × 2mm) Plastic DFN	$-40^{\circ}C$ to $125^{\circ}C$
LT3048EDC-15#PBF	LT3048EDC-15#TRPBF	LGKK	8-Lead (2mm × 2mm) Plastic DFN	$-40^{\circ}C$ to $125^{\circ}C$
LT3048IDC-15#PBF	LT3048IDC-15#TRPBF	LGKK	8-Lead (2mm × 2mm) Plastic DFN	$-40^{\circ}C$ to $125^{\circ}C$
LT3048EDC-12#PBF	LT3048EDC-12#TRPBF	LGQQ	8-Lead (2mm × 2mm) Plastic DFN	$-40^{\circ}C$ to $125^{\circ}C$
LT3048IDC-12#PBF	LT3048IDC-12#TRPBF	LGQQ	8-Lead (2mm × 2mm) Plastic DFN	$-40^{\circ}C$ to $125^{\circ}C$
LT3048EDC-5#PBF	LT3048EDC-5#TRPBF	LGQR	8-Lead (2mm × 2mm) Plastic DFN	$-40^{\circ}C$ to $125^{\circ}C$
LT3048IDC-5#PBF	LT3048IDC-5#TRPBF	LGQR	8-Lead (2mm × 2mm) Plastic DFN	$-40^{\circ}C$ to $125^{\circ}C$
LT3048EDC-3.3#PBF	LT3048EDC-3.3#TRPBF	LGQS	8-Lead (2mm × 2mm) Plastic DFN	$-40^{\circ}C$ to $125^{\circ}C$
LT3048IDC-3.3#PBF	LT3048IDC-3.3#TRPBF	LGQS	8-Lead (2mm × 2mm) Plastic DFN	$-40^{\circ}C$ to $125^{\circ}C$

Contact the factory for parts specified with wider operating temperature ranges.

[Tape and reel specifications](#). Some packages are available in 500 unit reels through designated sales channels with #TRMPBF suffix.

ELECTRICAL CHARACTERISTICS

The ● denotes the specifications which apply over the full operating temperature range, otherwise specifications are at $T_A = 25^\circ\text{C}$. $V_{IN} = 3.6\text{V}$, $EN/UVLO = 3\text{V}$, unless otherwise noted. Parameter applies to all options unless specified.

PARAMETER	CONDITIONS		MIN	TYP	MAX	UNITS
V_{IN} Operating Range			2.7		4.8	V
Boost Regulator						
BSTOUT-LDOOUT Regulation Voltage		●	1	1.1	1.2	V
BSTOUT- V_{IN} Regulation Voltage	$LDOOUT < V_{IN}$			1.1		V
V_{IN} Quiescent Current	Not Switching $EN \leq 0.4\text{V}$			475 0.1	600 1	μA μA
Switching Frequency	LT3048	●	0.75 0.7	1.00 1.00	1.25 1.30	MHz MHz
	LT3048-XX	●	1.7 1.6	2.2 2.2	2.7 2.8	MHz MHz
Maximum Duty Cycle	LT3048		93	95		%
	LT3048-XX		86	90		%
Switch Current Limit	(Note 3)		300	400	500	mA
Switch V_{CESAT}	$I_{SW} = 200\text{mA}$			220		mV
Diode Forward Drop	$I_{DIODE} = 100\text{mA}$			0.84		V
EN Voltage High			1.25			V
EN Voltage Low					0.4	V
LDO Linear Regulator						
LDO Quiescent Current	LT3048: Supplied by LDOIN			14	20	μA
	LT3048-XX: Supplied by BSTOUT			14	20	μA
FB Pin Current				60		nA
FB Regulation Voltage	LT3048: $I_{LOAD} = 100\mu\text{A}$, FB = LDOOUT		1.216	1.235	1.254	V
	LT3048: $100\mu\text{A} \leq I_{LOAD} \leq 40\text{mA}$	●	1.210	1.235	1.260	V
FB Load Regulation	LT3048: $\Delta I_{LOAD} = 100\mu\text{A}$ to 40mA			2	6	mV
LDOOUT Regulation Voltage	LT3048-15: $I_{LOAD} = 100\mu\text{A}$		14.775	15.00	15.225	V
	LT3048-15: $100\mu\text{A} \leq I_{LOAD} \leq 40\text{mA}$	●	14.625	15.00	15.375	V
	LT3048-12: $I_{LOAD} = 100\mu\text{A}$		11.82	12.00	12.18	V
	LT3048-12: $100\mu\text{A} \leq I_{LOAD} \leq 40\text{mA}$	●	11.70	12.00	12.30	V
	LT3048-5: $I_{LOAD} = 100\mu\text{A}$		4.925	5.00	5.075	V
	LT3048-5: $100\mu\text{A} \leq I_{LOAD} \leq 40\text{mA}$	●	4.875	5.00	5.125	V
	LT3048-3.3: $I_{LOAD} = 100\mu\text{A}$		3.250	3.300	3.350	V
	LT3048-3.3: $100\mu\text{A} \leq I_{LOAD} \leq 40\text{mA}$	●	3.217	3.300	3.383	V
LDOOUT Load Regulation	LT3048-15: $\Delta I_{LOAD} = 100\mu\text{A}$ to 40mA			20	45	mV
	LT3048-12: $\Delta I_{LOAD} = 100\mu\text{A}$ to 40mA			20	45	mV
	LT3048-5: $\Delta I_{LOAD} = 100\mu\text{A}$ to 40mA			12	25	mV
	LT3048-3.3: $\Delta I_{LOAD} = 100\mu\text{A}$ to 40mA			9	18	mV

LT3048 Series

ELECTRICAL CHARACTERISTICS The ● denotes the specifications which apply over the full operating temperature range, otherwise specifications are at $T_A = 25^\circ\text{C}$. $V_{IN} = 3.6\text{V}$, $EN/UVLO = 3\text{V}$, unless otherwise noted. Parameter applies to all options unless specified.

PARAMETER	CONDITIONS	MIN	TYP	MAX	UNITS
LDOOUT Voltage Noise BW = 10Hz to 100kHz $C_{OUT} = 1\mu\text{F}$	LT3048: $C_{BYP} = 0\text{nF}$, $I_{LOAD} = 40\text{mA}$, LDOOUT = 1.235V		38		μV_{RMS}
	LT3048: $C_{BYP} = 1\text{nF}$, $I_{LOAD} = 40\text{mA}$, LDOOUT = 1.235V		25		μV_{RMS}
	LT3048-15: $C_{BYP} = 0\text{nF}$, $I_{LOAD} = 24\text{mA}$		250		μV_{RMS}
	LT3048-15: $C_{BYP} = 1\text{nF}$, $I_{LOAD} = 24\text{mA}$		60		μV_{RMS}
	LT3048-12: $C_{BYP} = 0\text{nF}$, $I_{LOAD} = 31\text{mA}$		225		μV_{RMS}
	LT3048-12: $C_{BYP} = 1\text{nF}$, $I_{LOAD} = 31\text{mA}$		60		μV_{RMS}
	LT3048-5: $C_{BYP} = 0\text{nF}$, $I_{LOAD} = 40\text{mA}$		145		μV_{RMS}
	LT3048-5: $C_{BYP} = 1\text{nF}$, $I_{LOAD} = 40\text{mA}$		50		μV_{RMS}
	LT3048-3.3: $C_{BYP} = 0\text{nF}$, $I_{LOAD} = 40\text{mA}$		120		μV_{RMS}
	LT3048-3.3: $C_{BYP} = 1\text{nF}$, $I_{LOAD} = 40\text{mA}$		42		μV_{RMS}
Ripple Rejection	LT3048: $f_{\text{RIPPLE}} = 1.0\text{MHz}$, $I_{LOAD} = 40\text{mA}$		60		dB
	LT3048: $f_{\text{RIPPLE}} = 2.2\text{MHz}$, $I_{LOAD} = 40\text{mA}$		53		dB
Current Limit		●	45	80	mA

Note 1: Stresses beyond those listed under Absolute Maximum Ratings may cause permanent damage to the device. Exposure to any Absolute Maximum Rating condition for extended periods may affect device reliability and lifetime.

Note 2: The LT3048E is guaranteed to meet performance specifications from 0°C to 125°C junction temperature. Specifications over the -40°C to 125°C operating junction temperature range are assured by design, characterization and correlation with statistical process controls. The

LT3048I is guaranteed over the full -40°C to 125°C operating junction temperature range. High junction temperatures degrade operating lifetimes. Operating lifetime is derated at junction temperatures greater than 125°C .

Note 3: Current limit guaranteed by design and/or correlation to static test. Slope compensation reduces current limit at higher duty cycle.

TYPICAL PERFORMANCE CHARACTERISTICS

LT3048 FB Voltage

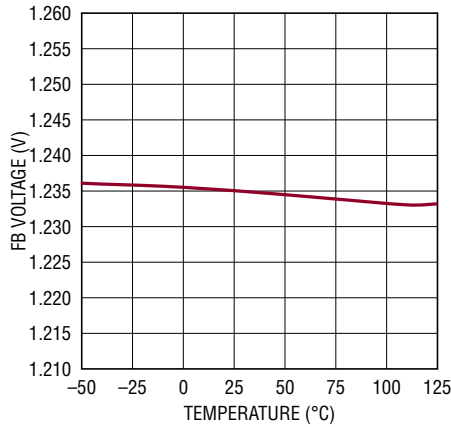

3048 G01

LT3048 FB Load Regulation

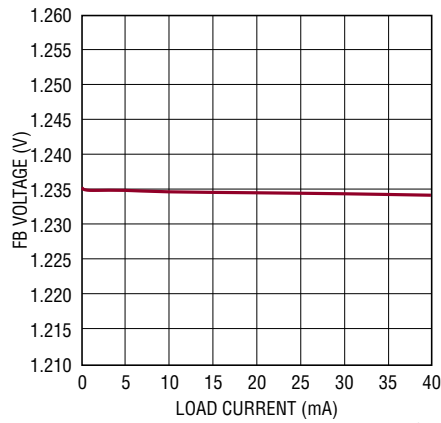

3048 G02

LT3048 Switching Frequency

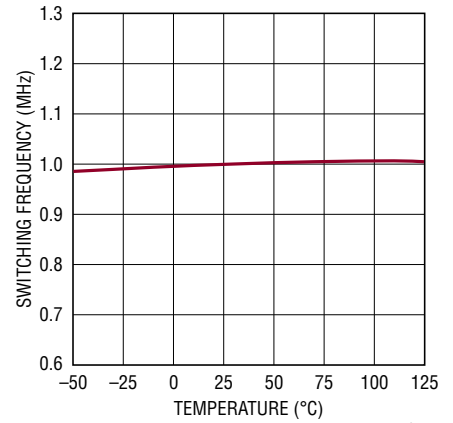

3048 G03

LT3048 LDOOUT Noise

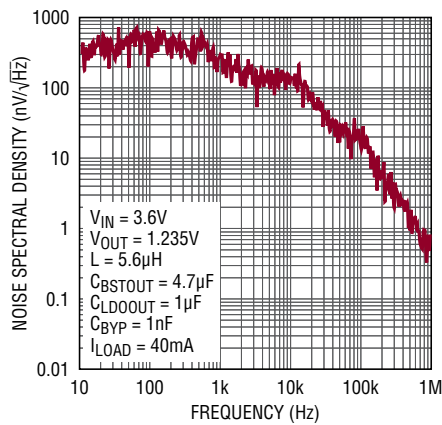

3048 G04

LT3048-15 Efficiency

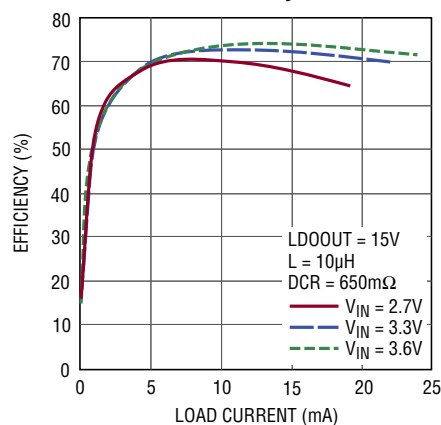

3048 G05

LT3048-15 LDOOUT Load Regulation

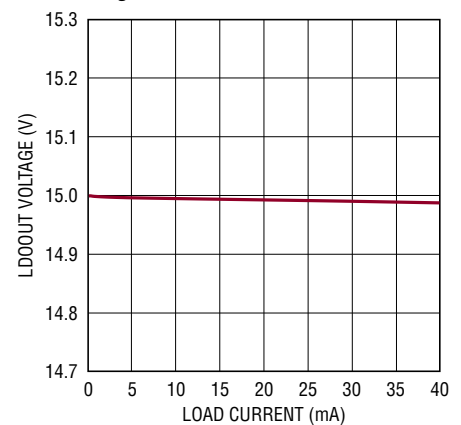

3048 G06

LT3048-15 LDOOUT Voltage

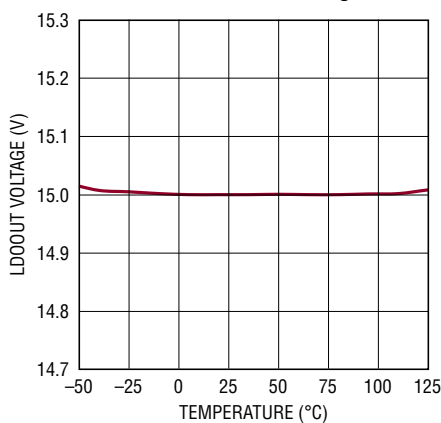

3048 G07

LT3048-15 Transient Response

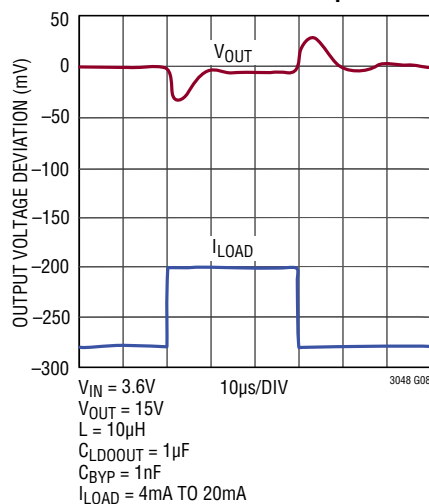

3048 G08

LT3048-15 LDOOUT Noise

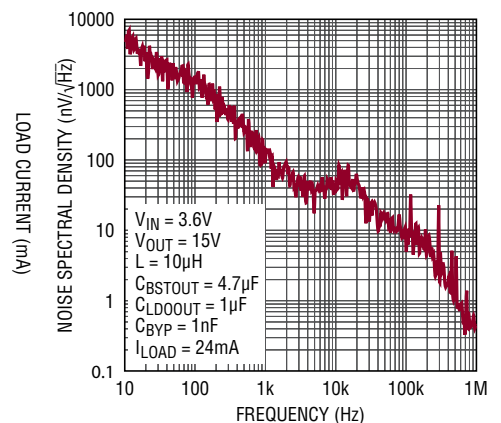

3048 G09

TYPICAL PERFORMANCE CHARACTERISTICS

Operating Waveforms: DCM

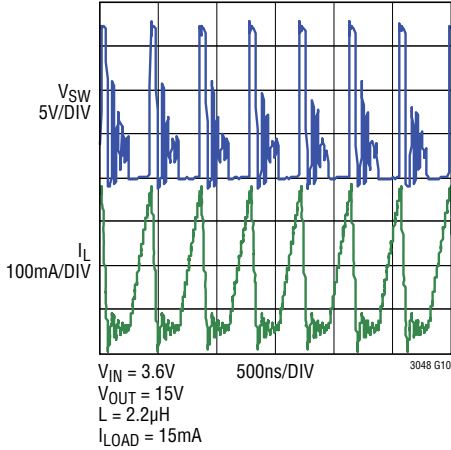

Operating Waveforms: CCM

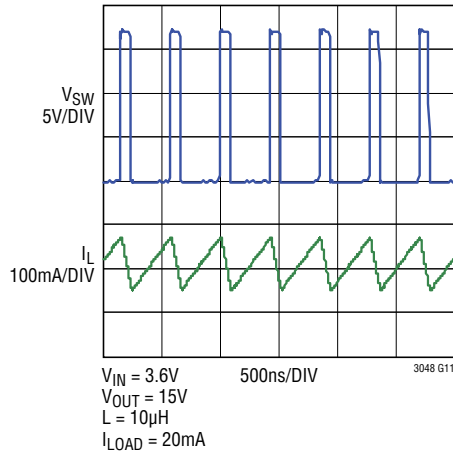

LT3048-12 Efficiency

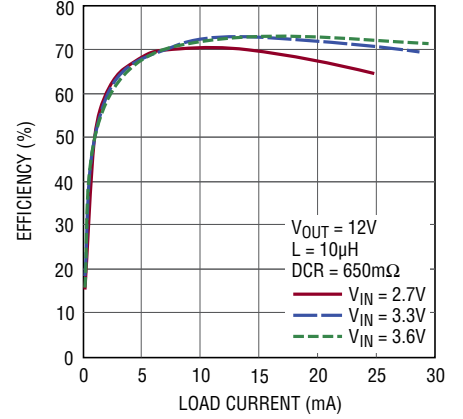

LT3048-12 LDOOUT Load Regulation

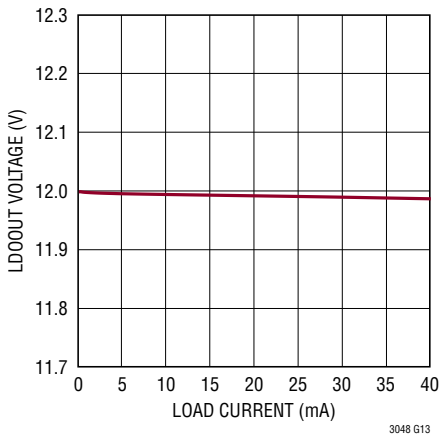

LT3048-12 LDOOUT Voltage

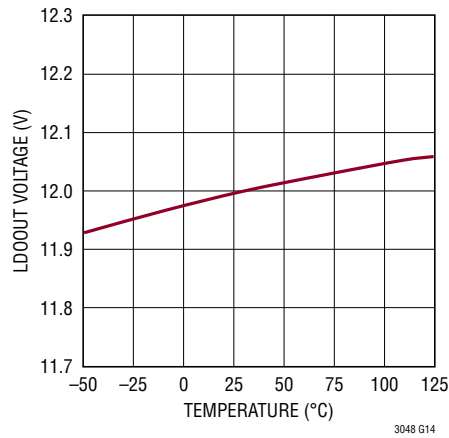

LT3048-12 LDOOUT Noise

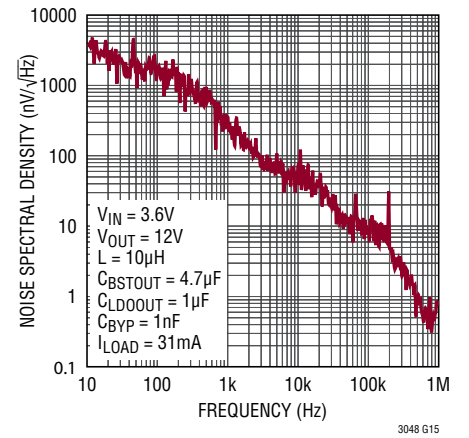

LT3048-5 Efficiency

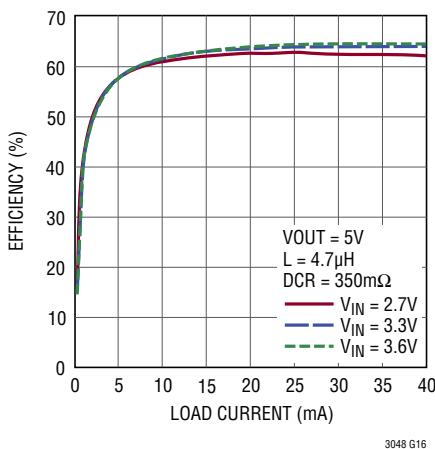

LT3048-5 LDOOUT Load Regulation

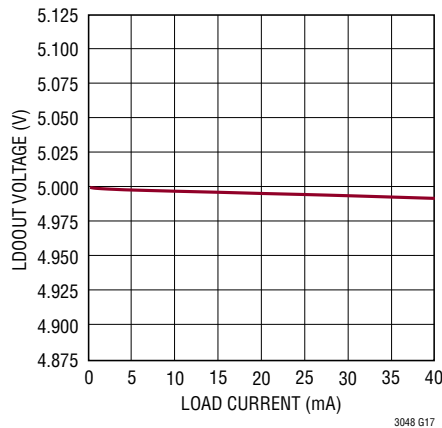

LT3048-5 LDOOUT Voltage

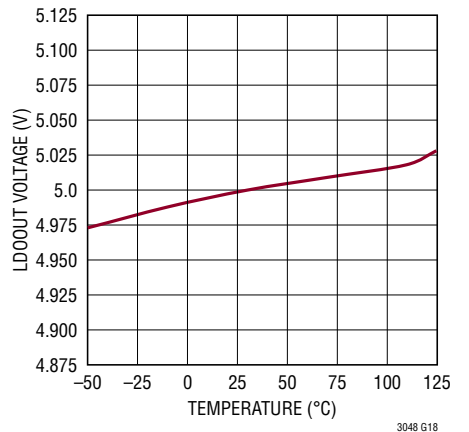

TYPICAL PERFORMANCE CHARACTERISTICS

LT3048-5 LDOOUT Noise

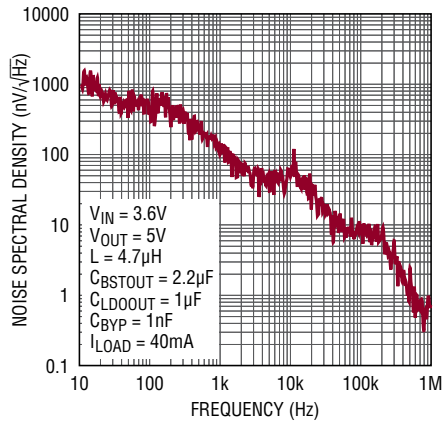

LT3048-3.3 Efficiency

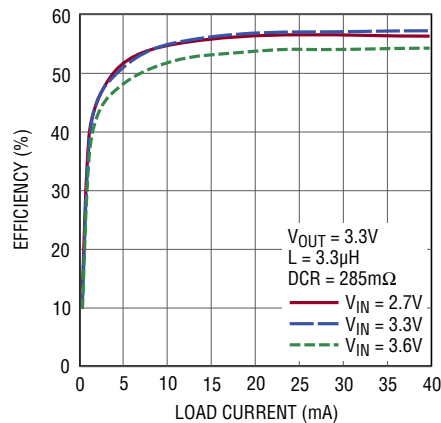

LT3048-3.3 LDOOUT Load Regulation

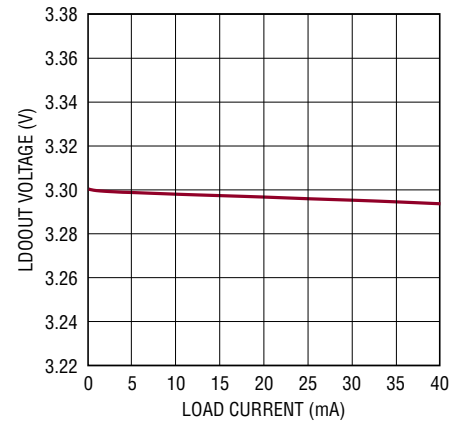

LT3048-3.3 LDOOUT Voltage

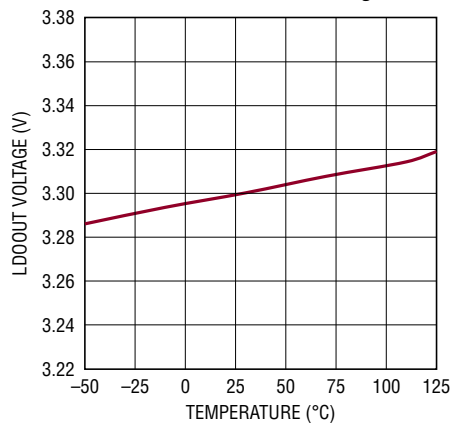

LT3048-3.3 LDOOUT Noise

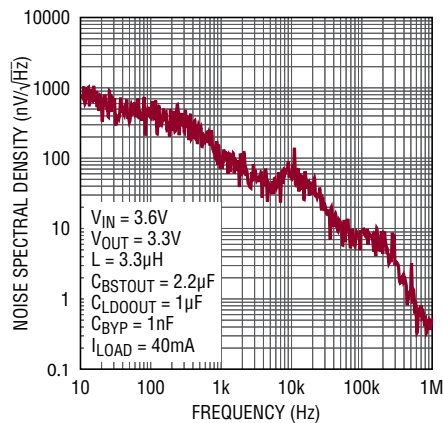

LDOOUT Current Limit

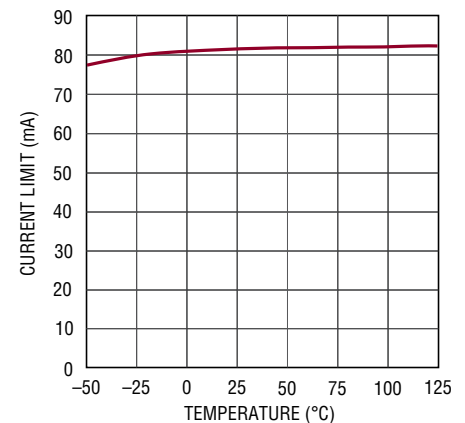

Boost Switch Current Limit

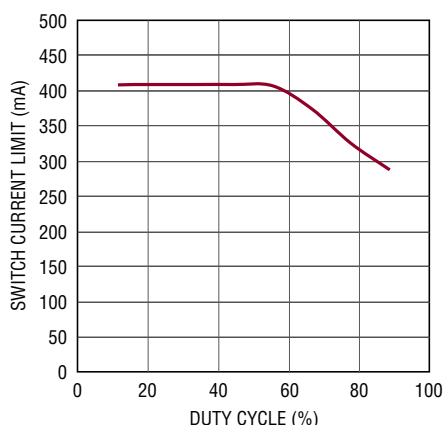

Boost Switch Current Limit

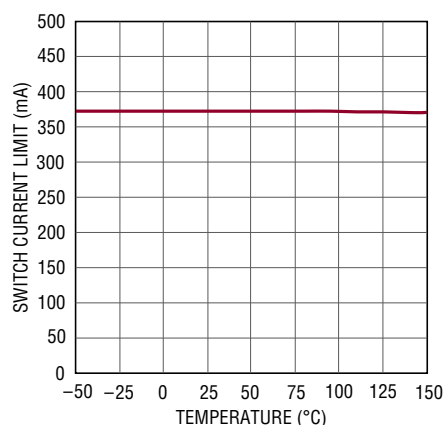

LT3048-XX Switching Frequency

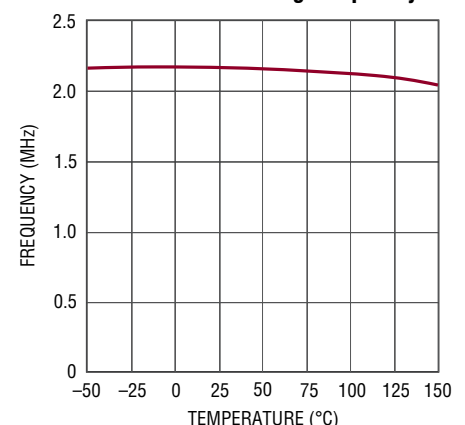

PIN FUNCTIONS

LT3048

SW (Pin 1): Boost Regulator Switch Node. This is the collector of the internal power transistor and the anode of the internal Schottky diode.

V_{IN} (Pin 2): Input Supply. Provides operating current to the boost regulator. Bypass to ground.

GND (Pin 3): Ground. This pin must be soldered to PCB ground. The exposed pad must also be soldered to PCB ground.

BYP (Pin 4): Bypass. Add an optional capacitor from LDOOUT to BYP to reduce noise at LDOOUT; otherwise leave BYP unconnected. A capacitor also soft-starts the linear regulator.

FB (Pin 5): The LT3048 regulates the FB pin to 1.235V. Connect the feedback resistor divider tap to this pin.

LDOOUT (Pin 6): LDO Linear Regulator Output. This pin is programmed by the feedback resistor divider. Bypass to ground with a minimum of 1 μ F.

EN (Pin 7): Enable. Logic input to enable the boost and linear regulator.

BSTOUT (Pin 8): Boost Regulator Output. This pin is connected to the internal Schottky diode and is regulated to 1.1V above LDOOUT. Bypass to ground.

GND (Exposed Pad Pin 9): The internal boost power switch is connected to the exposed pad. Tie to ground.

LT3048-XX

SW (Pin 1): Boost Regulator Switch Node. This is the collector of the internal power transistor and the anode of the internal Schottky diode.

V_{IN} (Pin 2): Input Supply. Provides operating current to the boost regulator. Bypass to ground.

GND (Pin 3): Ground. This pin must be soldered to PCB ground. The exposed pad must also be soldered to PCB ground.

BYP (Pin 4): Bypass. Add an optional capacitor from LDOOUT to BYP to reduce noise at LDOOUT; otherwise leave BYP unconnected. A capacitor also soft-starts the linear regulator.

LDOOUT (Pin 5): LDO Linear Regulator Output. This pin is regulated to a fixed voltage. Bypass to ground with a minimum of 1 μ F.

LDOIN (Pin 6): LDO Linear Regulator Input. Normally connected to BSTOUT. Bypass to ground.

EN (Pin 7): Enable. Logic input to enable the boost and linear regulator.

BSTOUT (Pin 8): Boost Regulator Output. This pin is connected to the internal Schottky diode and is regulated to 1.1V above LDOOUT. Bypass to ground.

GND (Exposed Pad Pin 9): The internal boost power switch is connected to the exposed pad. Tie to ground.

OPERATION

The LT3048 combines a boost regulator with a low drop-out linear regulator to produce a programmable output from a lower input voltage. The LT3048-15, LT3048-12, LT3048-5, LT3048-3.3 regulate to 15V, 12V, 5V and 3.3V, respectively. With EN below 0.4V, all circuits are turned off, Q2 disconnects the load from the input, and current consumption is less than 1µA. Driving EN high enables the oscillator and all bias circuits including voltage reference and regulation amplifiers.

The boost regulator uses peak current mode operation, providing cycle-by-cycle current regulation and limiting,

fast transient response, and good stability. The error amplifier, A1, regulates BSTOUT (and LDOIN) to 1.1V above LDOOUT or V_{IN} , whichever is higher.

Regulating 1.1V between LDOIN and LDOOUT allows the linear regulator to provide good transient response and ripple rejection, while maintaining good efficiency. This regulation loop also minimizes total power dissipation in fault conditions. If the output is overloaded, the linear regulator will enter current limit, LDOOUT voltage will decrease. By reducing the boost regulator output voltage, the voltage across Q2 will be reduced, limiting dissipation in Q2. Thermal shutdown provides additional protection.

APPLICATIONS INFORMATION

Capacitor Selection

A 4.7µF ceramic capacitor should be sufficient for the boost regulator output bypass. Low ESR (equivalent series resistance) ceramic capacitors should be used at the outputs of the regulator to minimize the output ripple voltage. Use only X5R or X7R dielectrics, as these materials retain their capacitance over wider voltage and temperature ranges better than other dielectrics.

Table 1. Ceramic Capacitor Manufacturers

MANUFACTURER	PHONE	WEB
Taiyo Yuden	(408) 573-4150	www.t-yuden.com
AVX	(803) 448-9411	www.avxcorp.com
Murata	(714) 852-2001	www.murata.com

FB Resistor Network

The output voltage is programmed with a resistor divider between the output and FB pin. Choose the 1% resistors according to:

$$R1 = R2 \left(\frac{V_{OUT}}{1.235V} - 1 \right)$$

R2 should be 200k or less to avoid bias current errors.

Inductor Selection

A 5.6µH inductor will suffice for most LT3048 applications. See Table 2 for recommended inductor values. Smaller value inductors can be used at the cost of reduced maximum load current. Figure 2 shows the maximum load current as a function of output voltage. The inductor's RMS current rating must be greater than the maximum input current. To keep efficiency high, the DCR (series resistance) should be minimized. Table 3 lists several vendors.

Table 2. Recommended Inductor Values

PART #	INDUCTANCE
LT3048	5.6µH
LT3048-15	10µH
LT3048-12	10µH
LT3048-5	4.7µH
LT3048-3.3	3.3µH

Table 3. Inductor Manufacturers

VENDOR	URL
Coilcraft	www.coilcraft.com
Sumida	www.sumida.com
Toko	www.toko.com
Würth Elektronik	www.we-online.com

APPLICATIONS INFORMATION

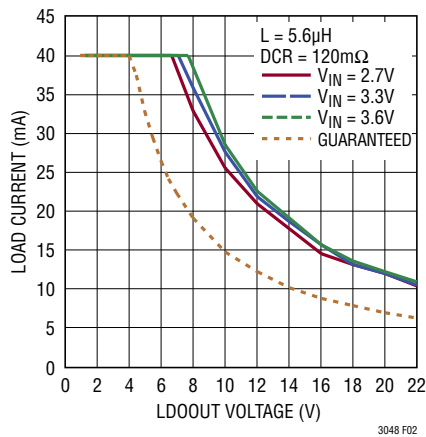

Figure 2. LT3048 Typical and Guaranteed Load Current vs. Output Voltage

Reducing Output Noise With A Bypass Capacitor

The LT3048 relies on the power supply rejection of the linear regulator to reduce switching regulator noise at LDOOUT. The linear regulator also contributes thermal noise to the output. The thermal noise can be reduced, and transient response improved, by adding a capacitor between LDOOUT and BYP. A typical value is 1nF. This capacitor increases start-up time of the regulator.

Recommended PCB Layout

Figure 3 shows the recommended layout for LT3048 circuits. Most important is careful placement of the BSTOUT bypass capacitor C2. High frequency AC current flows in a loop formed by C2, internal power transistor Q1 and boost diode D2. Keep this loop small. Also be sure to place an unbroken ground plane below this loop, on the highest copper layer below the surface. This prevents the AC loop from coupling to LDOOUT and other nearby circuitry. Keep the SW node as small as possible.

LDO Stability and Output Capacitance

The LT3048 linear regulator requires an output capacitor for stability. It is designed to be stable with most low ESR capacitors (typically ceramic, tantalum or low ESR electrolytic). A minimum output capacitor of 1µF with an ESR of 1Ω or less is recommended to prevent oscillations. Larger values of output capacitance decrease peak

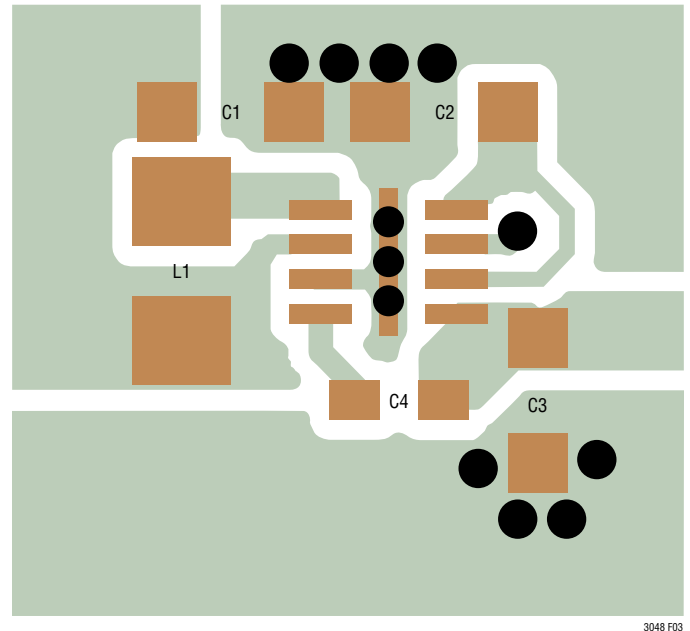

Figure 3. Recommended PCB Layout

deviations and provide improved transient response for larger load current changes. Bypass capacitors, used to decouple individual components powered by the LT3048, increase the effective output capacitor value.

Give consideration to the use of ceramic capacitors as they are manufactured with a variety of dielectrics, each with different behavior across temperature and applied voltage. The most common dielectrics used are specified with EIA codes of Z5U, Y5V, X5R and X7R. Typical voltage and temperature coefficients are shown in Figures 4 and 5. The X5R and X7R dielectrics have more stable characteristics and are most suitable for use as the output capacitor. The X7R type has better stability across temperature, while the X5R is less expensive and is available in higher values. Care still must be exercised when using X5R and X7R capacitors; the codes only specify operating temperature range and maximum capacitance change over temperature. Capacitance change due to DC bias with X5R and X7R capacitors can be significant enough to drop capacitor values below appropriate levels. Capacitor DC bias characteristics tend to improve as case size increases, but expected capacitance at operating voltage should be verified.

APPLICATIONS INFORMATION

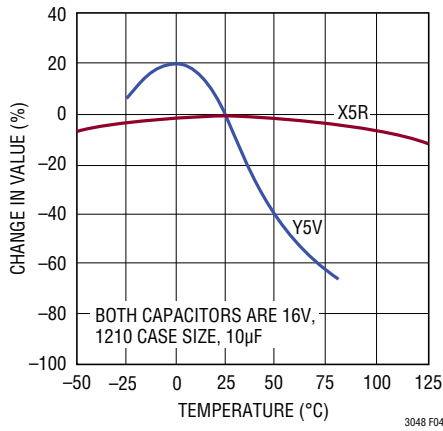

Figure 4. Ceramic Capacitor Temperature Characteristics

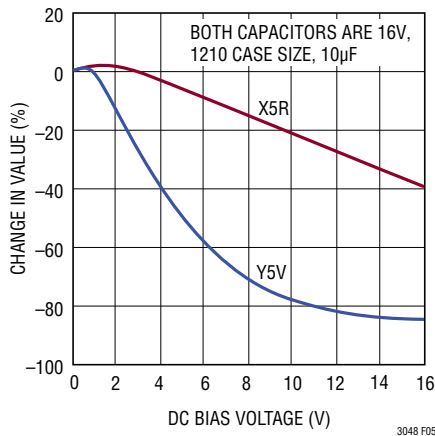

Figure 5. Ceramic Capacitor DC Bias Characteristics

Voltage and temperature coefficients are not the only sources of problems. Some ceramic capacitors have a piezoelectric response. A piezoelectric device generates voltage across its terminals due to mechanical stress. In a ceramic capacitor, the stress can be induced by vibrations in the system or thermal transients.

Wide Input Voltage Applications

The LT3048 can be used in wide input voltage applications. The input supply voltage to the LT3048 must be between 2.7V and 4.8V and capable of at least 10mA. The inductor can run off a separate voltage supply (PV_{IN}). This technique allows the output to be powered from 1V to 23V (see Figure 6).

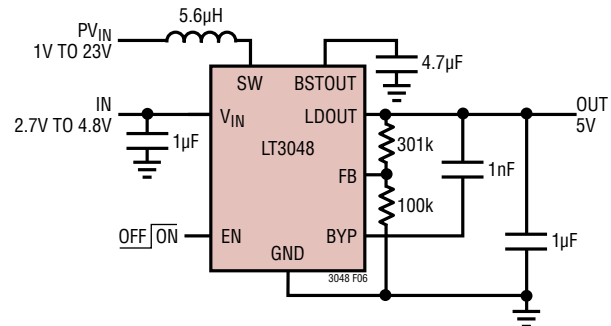
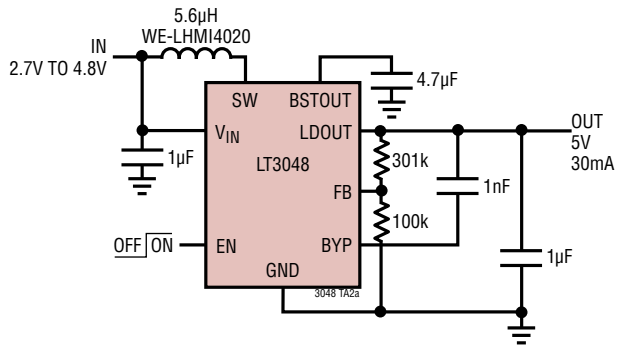

Figure 6. Connecting the Inductor to a Separate Voltage Supply

APPLICATIONS INFORMATION

LT3048



LT3048 Efficiency

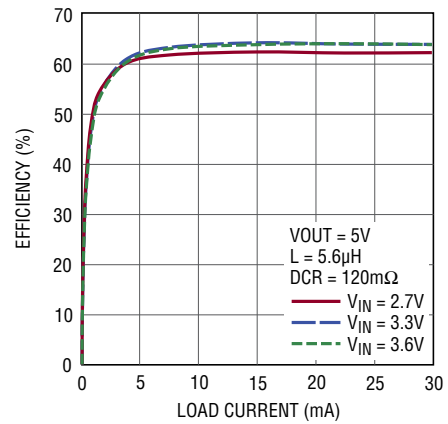

3048 TA02b

LT3048-15

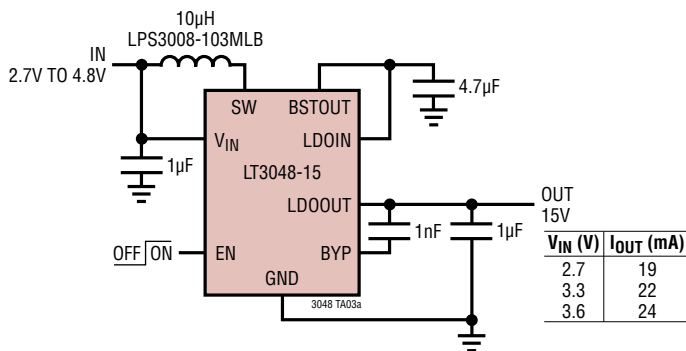

LT3048-15: Efficiency

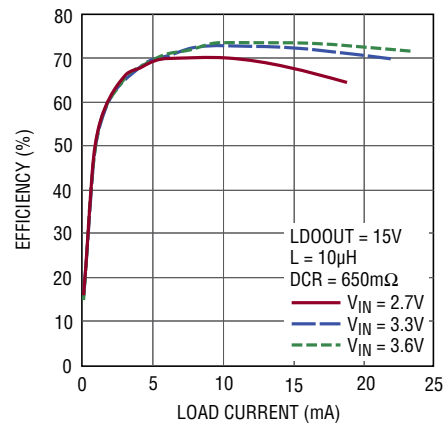

3048 TA03b

LT3048-12

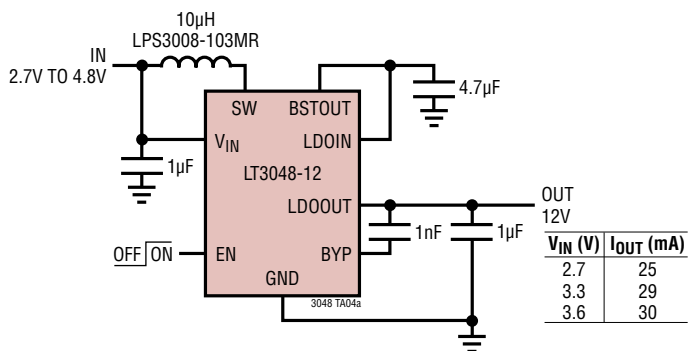

LT3048-12: Efficiency

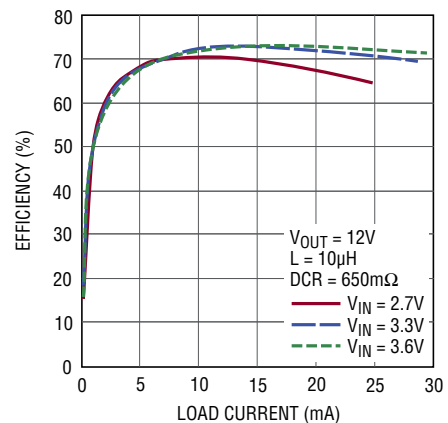

3048 TA04b

PACKAGE DESCRIPTION

DC8 Package
8-Lead Plastic DFN (2mm × 2mm)
 (Reference LTC DWG # 05-08-1939 Rev 0)
Exposed Pad Variation AA

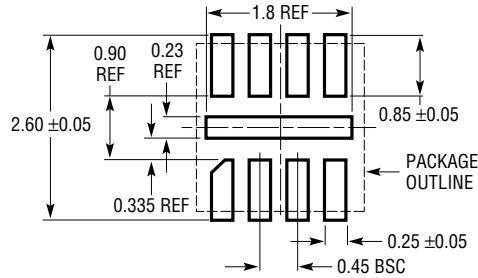

RECOMMENDED SOLDER PAD PITCH AND DIMENSIONS
 APPLY SOLDER MASK TO AREAS THAT ARE NOT SOLDERED

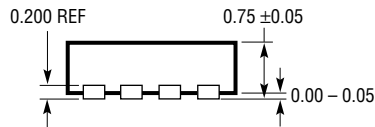
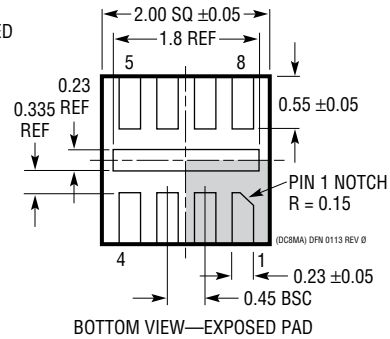
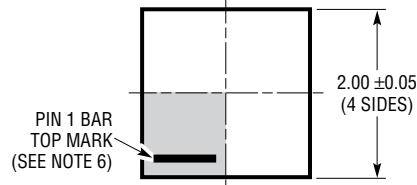

NOTE:

1. DRAWING IS NOT A JEDEC PACKAGE OUTLINE
2. DRAWING NOT TO SCALE
3. ALL DIMENSIONS ARE IN MILLIMETERS
4. DIMENSIONS OF EXPOSED PAD ON BOTTOM OF PACKAGE DO NOT INCLUDE MOLD FLASH. MOLD FLASH, IF PRESENT, SHALL NOT EXCEED 0.15mm ON ANY SIDE
5. EXPOSED PAD SHALL BE SOLDER PLATED
6. SHADED AREA IS ONLY A REFERENCE FOR PIN 1 LOCATION ON THE TOP AND BOTTOM OF PACKAGE

REVISION HISTORY

REV	DATE	DESCRIPTION	PAGE NUMBER
A	2/15	Clarified to Include All Fixed and Adjustable Output Options	1 – 16
B	12/18	Correct Typical Performance Characteristics Graphs Y Axis Values and Alignment: LT3048 & LT3048-XX Switching Frequency vs. Temperature, LT3048-12 LDOOUT Load Reg vs. Load Current & LT3048-12 LDOOUT Voltage vs. Temperature	5, 6, 7
		Correct FB Pin Function Feedback Voltage Value; Change From 1.25V to 1.235V	8
		Add LT3095 to Related Parts Section	16

TYPICAL APPLICATIONS

LT3048-5

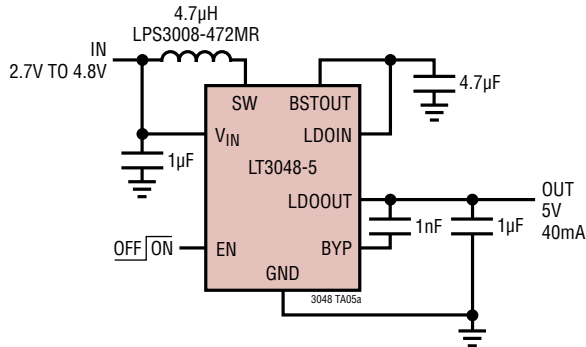

LT3048-5: Efficiency

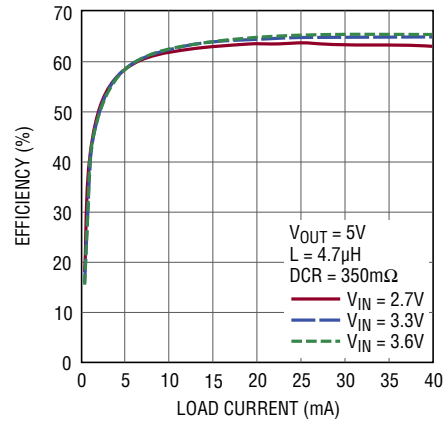

3048 TA05b

LT3048-3.3

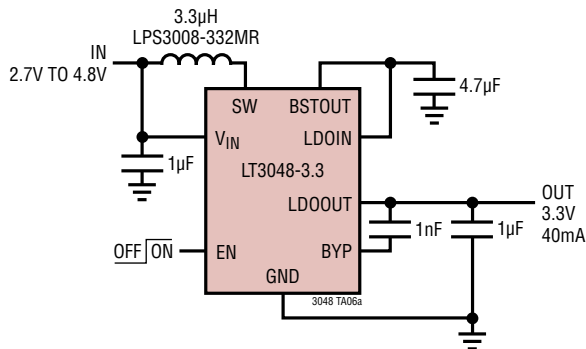

LT3048-3.3: Efficiency

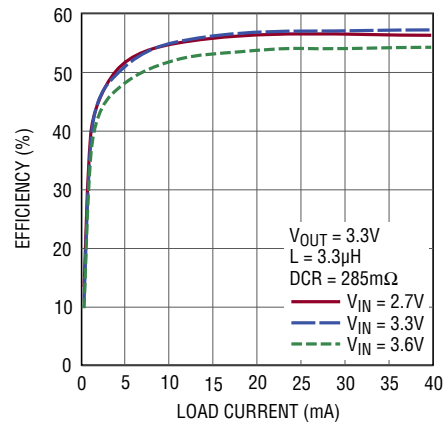

3048 TA06b

RELATED PARTS

PART NUMBER	DESCRIPTION	COMMENTS
LT3460	300mA, 38V I_{SW} , 1.3MHz, High Efficiency Step-Up DC/DC Converter	V_{IN} : 2.5V to 16V, $V_{OUT(MAX)}$ = 36V, I_Q = 2mA, I_{SD} < 1µA, SC70, ThinSOT™ Package
LT3461/LT3461A	300mA, 38V I_{SW} , 1.3MHz, High Efficiency Step-Up DC/DC Converters	V_{IN} : 2.5V to 16V, $V_{OUT(MAX)}$ = 38V, I_Q = 2.8mA, I_{SD} < 1µA, SC70, ThinSOT Packages
LT3464	120mA, 38V I_{SW} , High Efficiency Step-Up DC/DC Converter with Integrated Schottky, Output Disconnect	V_{IN} : 2.3V to 10V, $V_{OUT(MAX)}$ = 34V, I_Q = 25µA, I_{SD} < 1µA, ThinSOT Package
LT1613	550mA I_{SW} , 1.4MHz, High Efficiency Step-Up DC/DC Converter	V_{IN} : 0.9V to 10V, $V_{OUT(MAX)}$ = 34V, I_Q = 3mA, I_{SD} < 1µA, ThinSOT Package
LT1761	20V, 100mA (I_{OUT}) Low Noise LDO	V_{IN} : 1.8V to 20V, $V_{OUT(MIN)}$ = 1.22V, I_Q = 20µA, I_{SD} < 1µA, ThinSOT Package
LT3009	20V, 20mA (I_{OUT}) Low Noise LDO	V_{IN} : 1.6V to 20V, $V_{OUT(MIN)}$ = 0.6V, I_Q = 3µA, I_{SD} < 1µA, SC70, 2mm × 2mm DFN-6 Packages
LT3095	Dual-Channel Low Noise Bias Generators	V_{IN} : 3V to 20V, V_{OUT} : 1V to 20V, f_{SW} = 450kHz to 2MHz, Low Noise = 4µV _{RMS} (10Hz to 100kHz), 3mm × 5mm 24-Lead QFN-Package