

CONTENT

1. Application	-----	Sheet 3
2. General Specification	-----	Sheet 3
3. Absolute Maximum Ratings	-----	Sheet 4
4.Environmental condition	-----	Sheet 4
5. Electro-optical Specification (Ta=25)	-----	Sheet 5
5-1 Measuring method for transmittance	-----	Sheet 6
5-2 Measuring method for contrast	-----	Sheet 7
5-3 Measuring method for viewing angle	-----	Sheet 8
5-4 Measuring method for response time	-----	Sheet 9
6. Electrical Specification	-----	Sheet 10
(1) Contents	-----	Sheet 10
(2) Pixel arrangement and I / O interface pin assignment	-----	Sheet 10
(3) Interface	-----	Sheet 11
(4) Electrical specification	-----	Sheet 12
(5) Signal polarity and phase	-----	Sheet 13
(6) Timing characteristics of input signals	-----	Sheet 14
(7) Sequence for power - on / off and signal on / off	-----	Sheet 17
(8) Back light	-----	Sheet 18
7. Product Specification	-----	Sheet20
(1) Test Condition	-----	Sheet 20
(2) Line Defect	-----	Sheet 20
(3) Point Defect	-----	Sheet 20
(4) Bubble in polarizer	-----	Sheet 21
(5) Display's non - uniformity	-----	Sheet 21
8. Reliability specification	-----	Sheet 22
9. Serial number label	-----	Sheet 23
10. The package specification	-----	Sheet 24
11. Caution and Handling Precaution	-----	Sheet 25
12. Device outside view	-----	Sheet 28

1. Application

This specification is applied to the 18cm(7 inch) wide , full colors and 480×RGB×234 dots color TFT Liquid Crystal Display Module manufactured by Toshiba Matsushita Display Technology Co.,Ltd.

Controller circuit, inverter for lamp are not included in this module.

Production Code (Part No) : LTA070B311A

2. General Specification

CHARACTERISTIC ITEM	SPECIFICATION
1.Display technology	a-Si TFT active-matrix
2.Display mode	NW (normally white)
3.Module outer dimension (note2-1)	166.0(W) × 100.0(H) × 7.0(D) (Made by all SECC case)
4.Effective display area	154.08 × 86.58 mm
5.Number of dots	480(W) × 3(RGB) × 234(H)
6.Color-filter-array	RGB vertical stripes
7.Weight	185 g ±10 g
8.Backlight	CCFL with 3 wave-length spectrum L Type Combined use for CCFL, Harison and Stnley lamp.
9.Front surface treatment	AG coat (with WV film) Haze Ratio=7.2% (Typ)
10.Polarizer protective sheet	None
11.Appearance	There are not remarkable defects.
12.Metal frame condition	Not be connected to inner circuit

note 2-1: Detailed dimensions are shown as per "12. Device outside view".

3. Absolute Maximum Ratings

CHARACTERISTICS	SYMBOL	CONDITION	MIN.	MAX.	UNIT	REMARKS
Logic voltage	VDD	Ta=25	-0.3	6.5	V	
Source driver voltage	VEE	Ta=25	-0.3	6.5	V	
Logic signal voltage	VIN	Ta=25	-0.3	VDD+0.3	V	
Analog input voltage	VANA	Ta=25	-0.3	VEE+0.3	V	note 3-1
Gate driver positive voltage	VGON	Ta=25	-0.3	45	V	
Gate driver negative voltage	VSS	Ta=25	VGON-45	VGON+0.3	V	
Back light input voltage	VBL	Ta=25	-	3000	ACVrms	
Panel surface temp	-	-	-30	80		

note 3-1...Analog input voltages mean seven kinds of voltage such as VB, RED, GREEN, BLUE .

Attention)

Absolute maximum ratings are the limited value which must not be applied to the product even a second, and the product may have a permanent damage when it is exceeded.

Accordingly, please pay attention to the surge of input voltage, fluctuation and/or ripple of supply voltage, ambient temperature and so on.

4.Environmental Conditions

ITEM	SPECIFICATION	REMARKS
Operating Temperature (Panel surface temp.)	-20 ~ 70	note4-1,note4-2
Storage Temperature (Panel surface temp.)	-30 ~ 80	note4-2

note 4-1...This value guarantees only operation, but doesn't guarantee all the contents of Electro-optical specification.

Electro-optical specification can be guaranteed at the condition that ambient temperature is 25 .

note 4-2...Please refer to section 11. "Caution and Handling Precaution".

5. Electro-optical Specification

CHARACTERISTICS	SYM BOL	CONDITION			STANDARD VALUE			UNIT	measure ment method
				C.	MIN.	TYP.	MAX.		
1. Brightness *note	B	0°	0°	/	300	400	-	cd/m ²	5-1
2. Contrast Ratio	Cmax	best angle			60	150	-	-	5-2
3. White color chromaticity	X	0°	0°	/	0.27	0.31	0.35	-	5-1
	Y	0°	0°	/	0.29	0.33	0.37	-	
4. Brightness uniformity	-	0°	0°	/	0.7	-	-	-	5-1
5. Vertical viewing Angle	u	-	0°	10	40	60	-	°	5-3
	D	-	0°	10	20	30	-	°	
6. Horizontal Viewing Angle	L	0°	-	10	45	60	-	°	5-3
	R	0°	-	10	45	60	-	°	
7. Response Time	r	0°	0°	/	-	11	22	ms	5-4
	d	0°	0°	/	-	22	44	ms	
6 CF Haze ratio	/				6.9	7.2	7.5	%	Spec. of the polarizer

* note : Fluorescent lamp current is 6.5mA.

Measuring condition:

Measuring surroundings :Dark room or its coordinate

Measuring temperature :25±2 (Brightness)

:25±5 (others)

Measuring humidity :40 ~ 70%RH

Adjust operating voltage to get optimum contrast at the center of the display.
(more than 30 minutes after turning on back light)

Use inverter :HIU-742A; 16.5pF

Main viewing angle direction (Contrast ratio becomes max.)

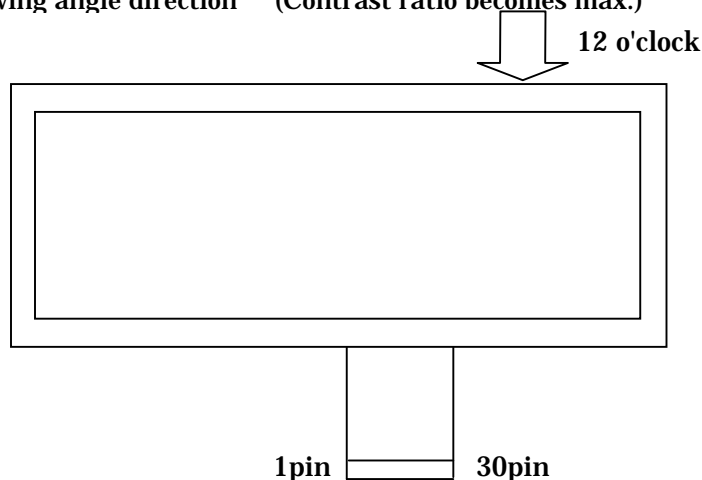

Connecting surface of FPC
is back side.

5-1. Measuring method for brightness

(1) Measuring instrument

TOPCON BM-5A (measuring field = 1°)

(2) Measuring point

Center of the display area (=0° , =0°)

: viewing angle against vertical axis

: viewing angle against horizontal axis

(3) Measuring method

Measure the brightness B(cd/m²) and white color chromaticity X,Y supplying signal voltage to get maximum brightness at the display pattern to be all white.

The distance from screen to "BM-5A" is 500mm.

Measure it after a lapse of at least 30 min. since a back light is turned on.

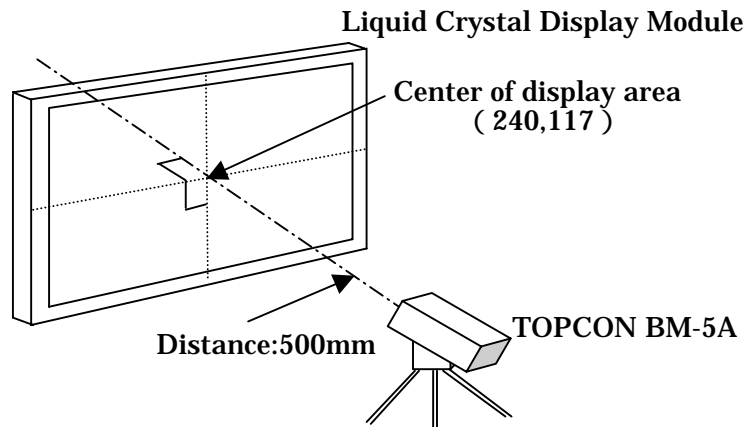

Definition of the brightness uniformity

Measure 5 points (S0 ~ S4) and define the brightness uniformity using the following formula.

Brightness uniformity = (The minimum brightness among S1 ~ S4)/S0

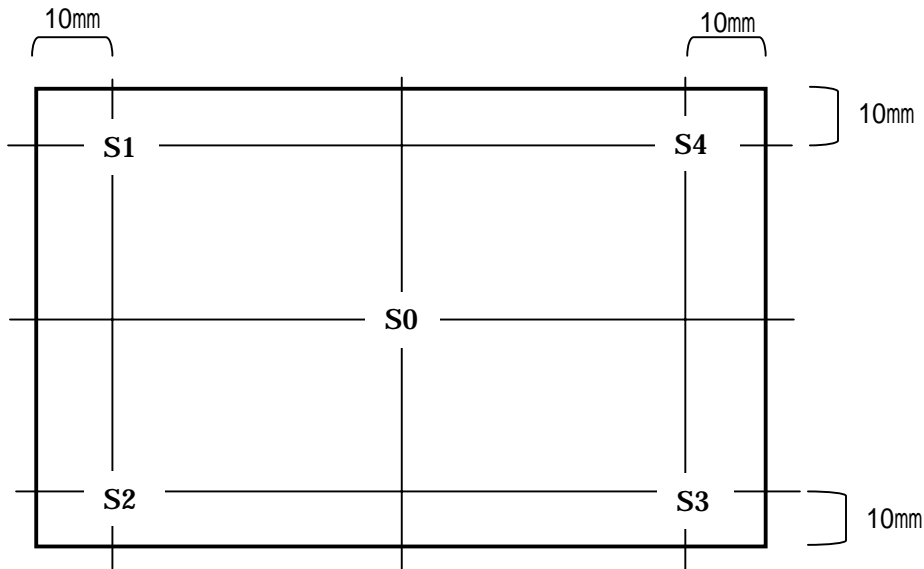

5-2. Measuring method for contrast

(1) Measuring instrument

TOPCON BM-5A (measuring field = 1°)

(2) Measuring point

Center of the display area : Exactly same point as that of measuring brightness.

(3) Measuring method

- Set the LCD module at $\theta = 0$, $\phi = 0$
 - : viewing angle in vertical axis
 - : viewing angle in horizontal axis

0 , 0 are the best angle to get the maximum contrast.
 - Measure maximum brightness "Y1"(Vlc=0v) and minimum brightness "Y2"(Vlc=5v).
 - The contrast ratio C is Y1/Y2.
- Where, Vlc means the effective voltage applied to liquid crystal in LCD panel.

5-3. Measuring method for viewing angle

(1) Measuring instrument

ELDIM : EZ contrast

(2) Measuring point

Center of the display area

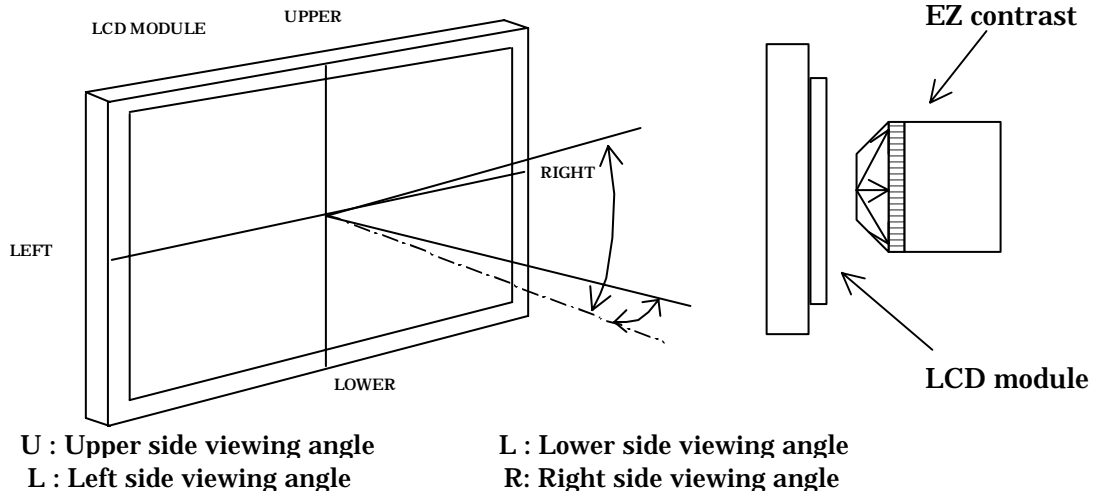

Record upper, lower, right, left angles of contrast 10 from circular chart data of EZ contrast.

5-4. Measuring method for response time

(1) Measuring instrument

Ohtsuka Electric. LCD evaluation equipment LCD-7000

Measuring spot size(aperture size) is 12mm.

(2) Measuring point

Center of the display area

(3) Measuring method

- Set LCD module at $\theta = 0^\circ$ and $\phi = 0^\circ$
- Apply the signal voltage at maximum contrast ratio and switch LCD-cell off/on/off.
(make screen white, then black and white)

When normalizing each brightness level corresponding to the display signal "OFF" and "ON" as shown in the figure below, the rise time r is defined as the time until the brightness level goes down

to 10% from 90% after display signal changed from OFF to ON and also fall-time d is defined as the time until the brightness level goes up to 90% from 10% after display signal changes from "ON" to "OFF".

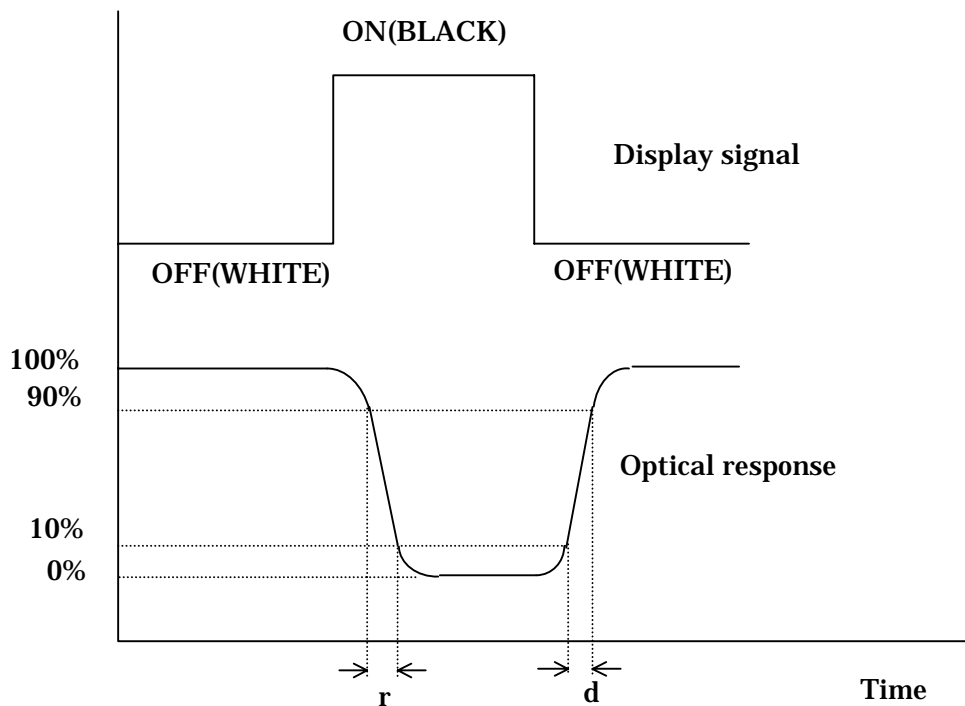

6. Electrical Specification**(1)Contents**

Item	Contents	Remark
Screen size	18 cm (7 inch) wide	
Display mode	TN type full color (Transmitting type)	Normally white
Driving method	a-Si TFT active-matrix line-at-a-time scan	
Pixel arrangement	RGB stripe arrangement	
Input video signal	RGB line-inverted	(Fig 6-1) Sheet 15
Control voltage	CMOS level	(Fig 6-2) Sheet 16
Backlight	Light-guiding plate with L type lamp	Sheet 18,19

(2)Pixel arrangement and I/O interface pin assignment

	1	2	3	4	5	6	1438	1439	1440
1	R	G	B	R	G	B	R	G	B
2	R	G	B	R	G	B	R	G	B
3	R	G	B	R	G	B	R	G	B
...
233	R	G	B	R	G	B	R	G	B
234	R	G	B	R	G	B	R	G	B

1pin

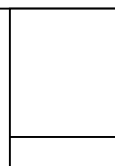

30pin

Connecting surface of FPC is back side
Surface treatment is gilding.

(3)Interface

Pin NO	SYMBOL	Function
1	VCOM	Voltage applied to color filter substrate
2	STH1	Source scanning start signal 1
3	VB	Source output current adjustment
4	RED	Red video signal
5	GREEN	Green video signal
6	BLUE	Blue video signal
7	OEH	Source driver output enable
8	VDD	Power line for logic
9	MOD	Sampling mode change (H: Simultaneous, L: Sequential)
10	CLK1	Source driver clock input 1
11	CLK2	Source driver clock input 2 (Set "H" at Simultaneous Mode)
12	CLK3	Source driver clock input 3 (Set "H" at Simultaneous Mode)
13	RL	Right / Left scanning change
14	STH2	Source scanning start Signal 2
15	VEE	Power line for source driver IC
16	GND	Ground
17	VCOM	Voltage applied to color filter substrate
18	STV2	Gate scanning start signal 2
19	OEV3	Gate driver output enable 3
20	OEV2	Gate driver output enable 2
21	OEV1	Gate driver output enable 1
22	CPV	Gate driver scanning clock pulse
23	U/D	Up/Down scanning change
24	STV1	Gate scanning start signal 1
25	NC	Non connect
26	VSS	Gate driver negative voltage
27	GND	Ground
28	VDD	Power line for logic
29	NC	Non connect
30	VGON	Gate driver positive voltage

Connector : IL - FPR Series (0.5mm pitch 30p) (JAE) gilded type

4)Electrical Specification

Under TFT LCD Module operating condition

ITEM	SYMBOL	MIN.	TYP.	MAX.	UNIT	REMARKS
IC logic voltage	VDD	2.70	3.00 ~ 3.30	3.60	V	
Source driver IC voltage	VEE	4.50	5.00	5.50	V	
Logic signal input voltage	VIL	0	-	0.20*VDD	V	
	VIH	0.80*VDD	-	VDD	V	
Black input voltage(+)	VSB+	(0.20)	0.75	(VSW+)	V	R,G,B, VEE=5V
White input voltage(+)	VSW+	(VSB+)	4.25	(4.80)	V	R,G,B, VEE=5V
Black input voltage(-)	VSB-	(VSW-)	4.25	(4.80)	V	R,G,B, VEE=5V
White input voltage(-)	VSW-	(0.20)	0.75	(VSB-)	V	R,G,B, VEE=5V
Source signal width	VSPP	-	3.50	VEE-0.4	V	R,G,B, note 6-4
Source driver center voltage	VSC	2.30	VEE/2	2.70	V	R,G,B
Source output current adjustment	VB	2.10	2.30	2.50	V	VEE=5.0V
					V	VSPP=3.5V
					V	VCPP=7.0V
Gate driver positive voltage	VGON	16.00	17.00	18.00	V	
Gate driver negative voltage	VSS	-14.00	-13.00	-12.00	V	
V center applied to color filter sub.	VCOM	-0.50	0.50	1.50	V	note 6-2
V amplitude applied to color filter sub.	VCPP	3.00	7.00	9.00	Vpp	note 6-1, 6-4
Logic supply current	IDD	-	1.79	3.60	mA	VDD=3.3V, note 6-3
Source driver IC supply current	IEE	-	19.60	39.20	mA	VEE=5.0V, VB=2.5V, note 6-3
Gate driver IC positive supply current	IGH	-	0.12	1.00	mA	VGON=17.0V, note 6-3
Gate driver IC negative supply current	ISS	-	-0.30	-1.00	mA	VSS=-13.0V, note 6-3

note 6-1...Brightness level is adjusted by varying this amplitude.

note 6-2...Please adjust VCOM voltage between -1.5V and +2.5V to make the flicker level be minimum.

note 6-3...Current value is an average level , not a peak level.

note 6-4... $VSPP/2+VCPP/2 < 5.5(V)$ Please keep this condition for picture quality.

Attention) Electrical specification guarantees the normal operation of the product. In case of using the product over electrical specification, the normal operation is not guaranteed even within absolute maximum ratings.

The function of STV1 and STV2 is changed as follows by the U/D terminal (up/down scanning)

UD	STV1	STV2
H (VDD)	Signal Input	Signal Output
L(0V)	Signal Output	Signal Input

The function of STH1 and STH2 is changed as follows by the RL terminal (Right/Left scanning)

RL	STH1	STH2
H (VDD)	Signal Input	Signal Output
L(0V)	Signal Output	Signal Input

(5)Signal polarity and phase

It is needed to modulate RGB Video signal (inverted polarity line by line), the voltage applied to color filter substrate (Vcom) synchronizing inversion timing.

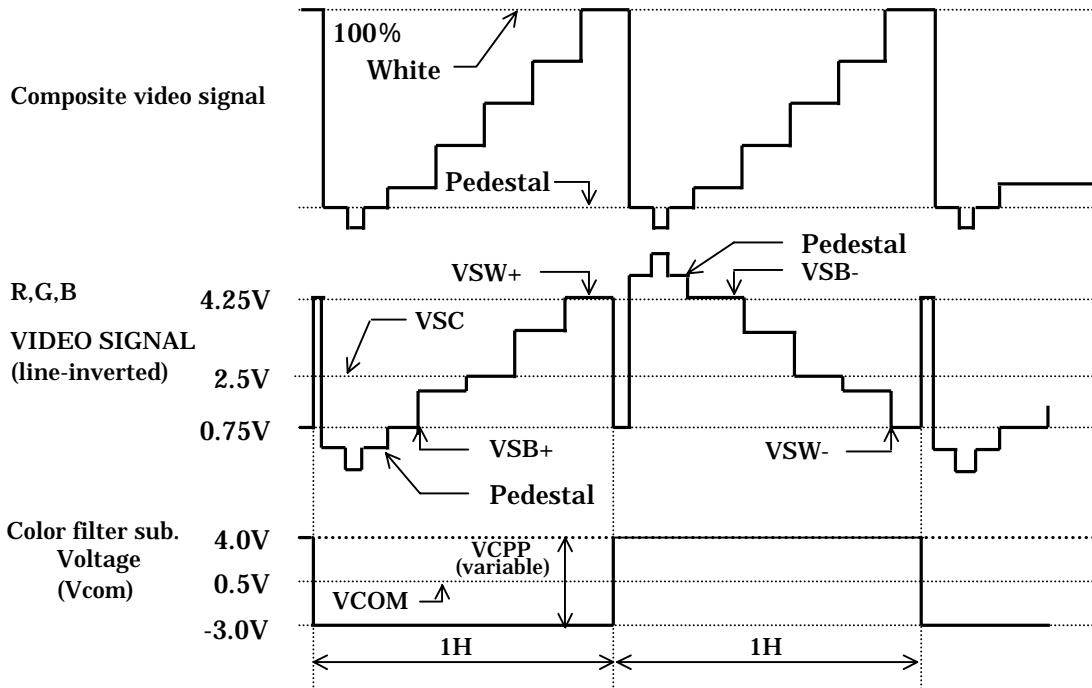

note · Please adjust the brightness level by varying the amplitude of Vcpp.

Relation of Black/White display and signal Voltages

video signal	Vcom	
	H level	L level
higher voltage	Black	White
lower voltage	White	Black

(6) Timing characteristics of input signals

CHARACTERISTICS	SYMBOL	MIN	TYP	MAX	UNIT	REMARKS
1 Field scanning period	t1V	-	262.5	-	H	
1 Line scanning period	t1H	-	63.5	-	μs	
Source driver operating frequency	fhc	1.00	9.56	10.00	MHz	full scan mode
	fhc			(14.4)	MHz	side panel area
Signal sampling pulse width	tchw	100.0	104.6	1000.0	ns	
Signal sampling pulse delay	tchd	31.4	34.9	38.4	ns	
Signal sampling pulse width(H)	tchwh	47.1	52.3	57.5	ns	tchd 12,23
Signal sampling pulse width(L)	tchwl	47.1	52.3	57.5	ns	
Source start signal pulse width	tshw	30.0	104.6	208.0*	ns	*shset=tshhld
Source start signal setup time	tshset	10.0	52.3	-	ns	
Source start signal hold time	tshhld	20.0	52.3	-	ns	
Source output enable pulse width	tohw	7.5	8.0	8.5	μs	
Source start signal rising time	tss	1.45	9.85	10.96	μs	
Video input signal start point	tvsv	1.59	10.0	11.11	μs	
Phase difference between OEH & CPV	toc	1.5	2.3	-	μs	
Gate clock period	tcvsw	10.0	63.5	-	μs	
Gate clock pulse width (H)	tcvwh	5.0	10.3	58.5	μs	
Gate clock pulse width (L)	tsvwl	5.0	53.2	58.5	μs	
Gate start signal pulse width	tsvw	5.0	63.5	126.0*	μs	**tsvset=tsvhld
Gate start signal setup time	tsvset	2.0	31.75	-	μs	
Gate start signal hold time	tsvhld	2.0	31.75	-	μs	
Phase difference between OEH & STH	tosp	0.0	0.5	-	μs	
Phase difference between SYNC & OEH	tohs	-	1.4	1.9	μs	

- note) · Rise time (tr) and fall time (tf) of source driver logic signal are less than 6ns.
· Rise time (tr) and fall time (tf) of gate driver logic signal are less than 50ns.
· Rise time (tr) and fall time (tf) of OEH are less than 200ns.
· Rise time (tr) and fall time (tf) of OEV are less than 200ns.
· Rise time (tr) and fall time (tf) is defined as the time from 0% to 63.2%.

(Fig.6-1) Video signal timing chart

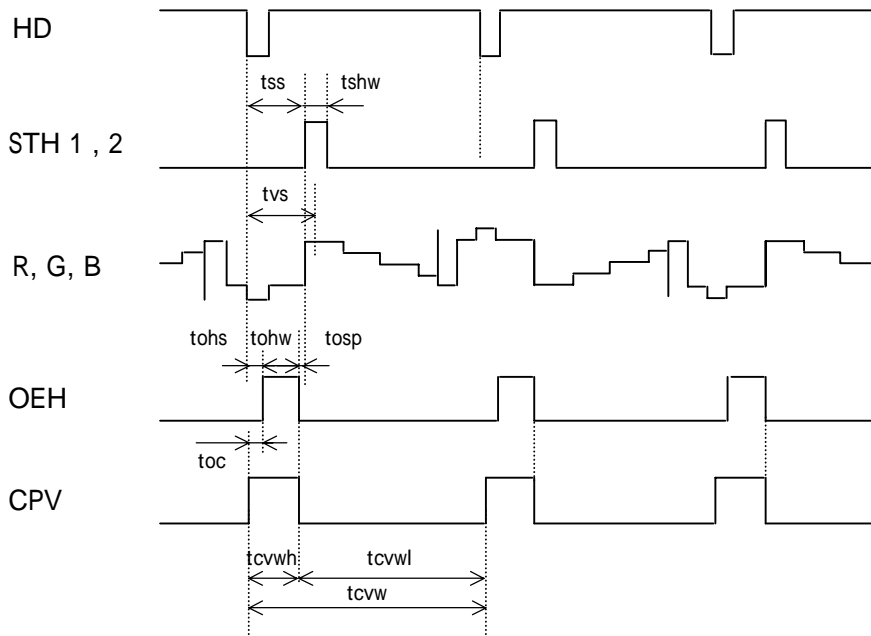
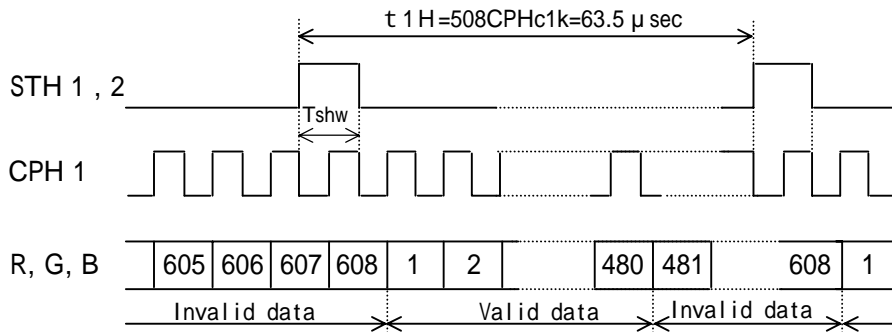
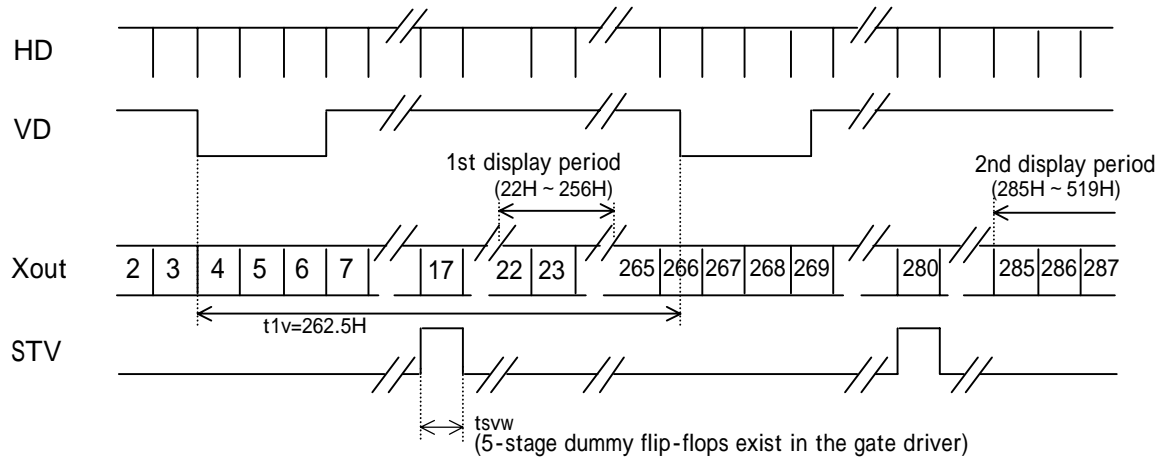

(Fig. 6-2)Control signal timing diagram

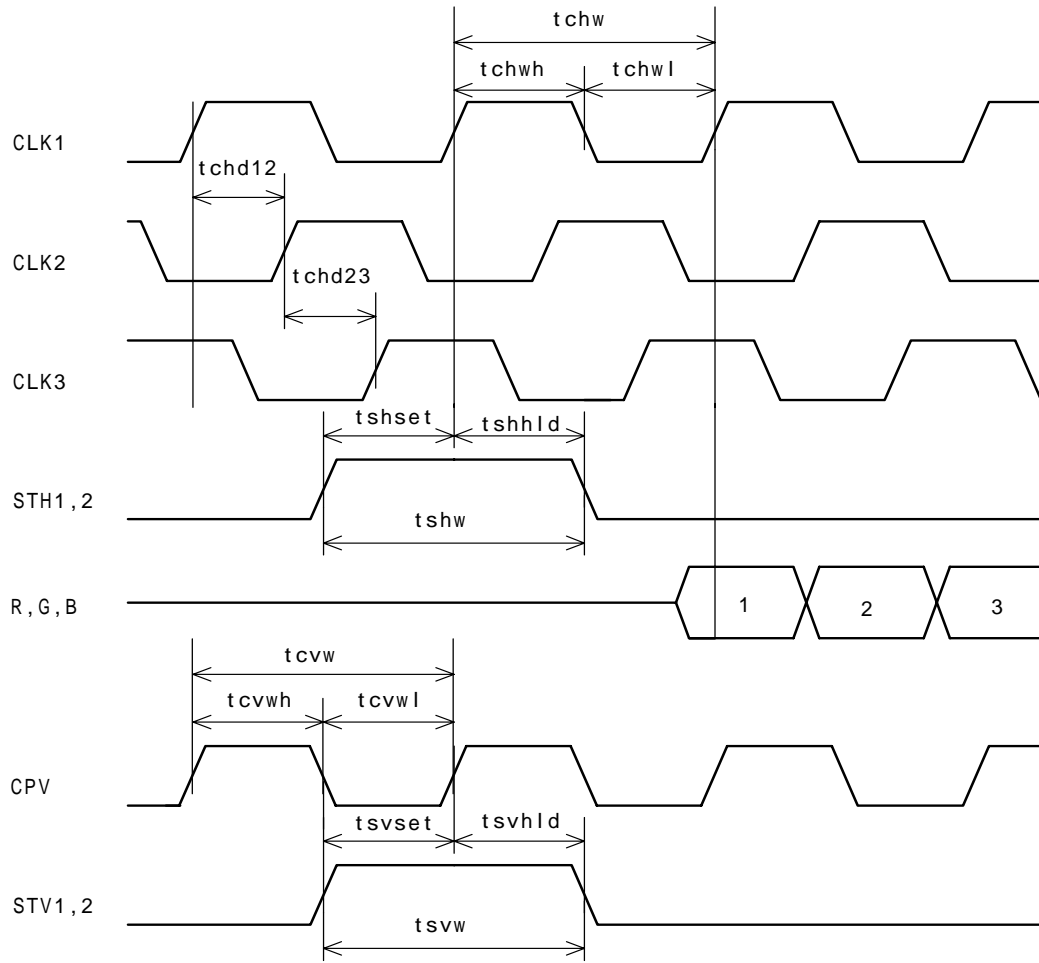

(7)Sequence for power-on /off and signal on / off

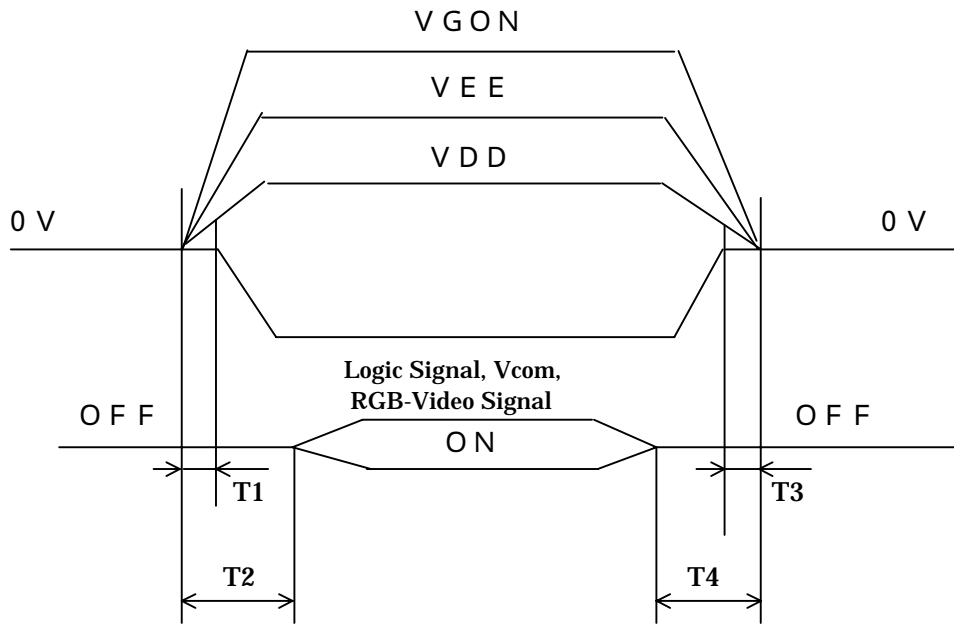

1) 10 ms $T1 < T2, 0 < T3 < T4$ 10 ms

2) Please use the schottky Barrier Diode among VDD ,VEE and VGON, shown as follows.

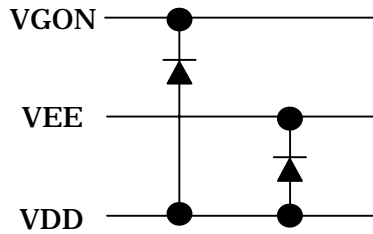

(8) Backlight

CHARACTERISTICS	SYMBOL	MIN	TYP	MAX	UNIT	REMARKS
Lamp current	IL	3.0	6.5	7.0	mArms	
Lamp voltage	VL	-	550	-	Vrms	
Lamp power consumption	PL	-	3.6	-	W _{rms}	
Possible lighting frequency	FL	-	30 ~ 70	-	kHz	
Starting voltage	VS	-	-	1800	Vrms	Ta=0
Life time	-	10000	-	-	Hour	

Attention)

- *1 Panel surface temperature should be kept less than contents of "3. Absolute Maximum Ratings".
- *2 Inverter should be designed to be subject to the conditions below:
- (1) Both the area and the peak under the positive and negative cycles of the waveform of the lamp current and lamp voltage should be symmetric.
(The symmetric ratio should be larger than 90%)
 - (2) There should not be any spikes in the waveform.
 - (3) The waveform should be close to a sine wave whenever possible.
 - (4) Lamp current should not exceed the "MAX" value under the "Operating Temperature" (It is prohibited to exceed the "MAX" value even if it is operated in the non-guaranteed temperature). When lamp current exceed the maximum value for a long time, it may cause a smoking and ignition. Therefore, it is recommended that the inverter have the current limited circuit that is used as a protection circuit and/or the lamp current-controlled inverter.
 - (5) Please check the lamp current not to exceed the "MAX" value in the inverter open/short test.
 - (6) The "MIN" of "Lamp current " is the necessary value which must not be applied to the product for an stable working condition.
Please pay attention to keep the "MIN" of "Lamp current" for a light dimmer.
- *3 The lamp frequency should be selected as different as possible from display horizontal synchronous signal (Including harmonic frequency of this scanning frequency) to avoid "Beat "interference which may be observed on the screen as horizontal stripes like moving wave.
This phenomenon is caused by interference between lamp (CCFL) lighting frequency and LCD horizontal synchronous signal.
- *4 "Life time" is defined as a lamp maker's warranty value which applied to CCFL only.
"Life time" is defined as the lamp brightness decrease to 50% original brightness at IL=MAX; continuous lighting, Ta=25 .

*5 Values of "Lamp Voltage", "Lamp power consumption" and "Starting voltage" are defined on condition of the LCD module derived by Toshiba Matsushita Display Technology Co.,Ltd. standard inverter (Harison HIU-742A; 16.5pF).

The "MAX" of "Starting voltage "means the minimum voltage to light normally in the LCD module.

However this isn't the values that we can assure stability of starting lamp on condition that the module is installed in your set.

It is careful that "Starting voltage" is changed by an increase of stray capacitance in your set, inverter method, value of ballast capacitor in your inverter and so on.

Especially, the value of "Starting voltage" is higher in low temperature condition than in normal temperature condition, because impedance of CCFL is increased.

So, please check your set in low temperature condition.

*6 Please do not bring the high voltage wire into contact with metallic frame and the GND lead wire, so as to ensure the safety and decrease the difference of brightness.

*7 "Starting Voltage" and "Lamp voltage" are defined as follows.

(1) Starting voltage

*Use inverter : HIU-742A; 16.5pF

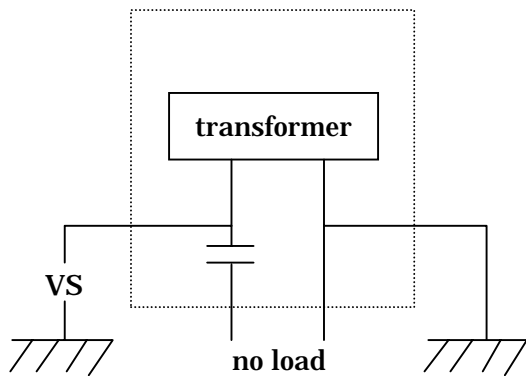

(2) Lamp voltage

*Use inverter : HIU-742A; 16.5pF

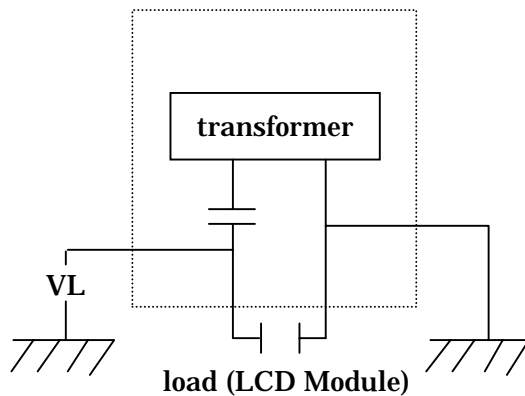

Lamp Connector

Use Connector : BHR - 02VS - 1 (JST)

Pin No.	SYMBOL	FUNCTION	REMARKS
1	L	CCFL power supply (Ground)	cable color : White
2	H	CCFL Power supply (High Voltage)	cable color : Red

7. Product specification**(1)Test Condition**

Environment ...Dark room or its coordinate, temperature :25±5 , Humidity :40 ~ 70%RH
 Supply voltage...Standard Value
 Input Signal ... Standard Value
 Back Light...Flat light source

(2)Line Defect Nothing

(3)Point Defect

ITEM		SPECIFICATION		UNIT	REMARK
(1)Brighten Spot *7-1	R	2		dot	P means pixel.
	G	2			
(2)Black Spot *7-2		10			
(3)Foreign object		P 3	20	*7-3	
		3 < P 7	4	unit	
		7 < P	None		
Acceptable defect numbers		Total count of No. , , , and blue brighten spot should be 10			
Relative position		Distance between two countable level brighten spots should be over 5mm. Acceptable number of adjacent brighten spots should be less than 2. Acceptable number of adjacent black spots should be less than or equal to 2. In the case of (3) even within acceptable numbers, the distance between two countable defects should be over 5 mm.			

note)

- In the test condition , the brightness level at the surface of LCD panel is 400±100cd/m², the distance for inspection is 30cm .
- Brighten spot is defined as the spot which is constantly lighted on when black image is displayed in the LCD panel screen.
- Black spot is defined as the spot which is constantly lighted off when white image is displayed in the LCD panel screen.

*7-1 Countable level as brighten spot or black spot is over 50% of each dot .

As for adjacent brighten spot,less than two dots are counted as one.

As for adjacent black spot, less than or equal to two dots are counted as one .

*7-2 This includes the defect in the LCD panel cell being able to recognize when LCD panel is operated.

*7-3 This is not recognizable level ,so if necessary, discussion will be held when appropriate limiting sample is found.

(4)Bubble between polarizer and LCD glass, Dent (Apply to both side of AR and CF)

Size	Zone		Unit
	Affective display area	Part of BM	
D : Average diameter (mm)	5	Ignore	pcs
D < 0 . 3	0		

Note

1. Above criteria assumes inconspicuous of defect.
2. Limiting sample will be established if necessary.

(5)Peeling of polarizer

Zone		Unit
Affective display area	Part of BM	
0	Ignore	pcs

Note

1. Above criteria assumes inconspicuous of defect.
2. Limiting sample will be established if necessary.

(6)Non uniformity

1. Non uniformity is not recognized through 2.5% ND filter at white raster, black, gray pattern.
2. Limiting sample will be established if necessary.

(7)Appearance defect (glass scratches and so on)

1. Limiting sample will be established if necessary.

(8)Inspection area

Inspection area of BM area is 1mm perimeter of affective display area.

8. Reliability specification

TEST ITEM	TEST CONDITION	JUDGMENT
(1) Operation at high temperature	70 192h (LCD panel surface temperature)	After test, display should maintain the contents (2) ~ (5) of "7. Product specification".
(2) Operation at low temperature	-20 192h (ambient temperature)	
(3) Operation at high temperature and high humidity	55 90% 192h (ambient temperature)	
(4) High temperature exposure	80 192h	
(5) Low temperature exposure	-30 192h	
(6) Heat shock	-20 / 70 (0.5h/0.5h)50 cycles	
(7) Electrostatic withstanding voltage	Panel surface :150pF ± 15 kV 150 (direct discharge ,five times) FPC input terminal : 100pF ±200V 0	Operate normally after test
(8) Product drop test	490m/s ² , 11msec half-sine pulse Once for each direction of X, Y and Z.	
(9) Product vibration test	10 ~ 57 Hz : width 0.075mm 58 ~ 500 Hz: 9.8m/s ² peak 11 minutes / cycle 3 hours (one hour each for X,Y and Z.)	
(10) Packaged vibration test	5 ~ 50 Hz Z direction 9.8m/s ² /54 minutes X,Y direction 4.9m/s ² /27 minutes	Operate normally after test. There are not remarkable defects.
(11) Packaged drop test	Bottom surface : 40cm Others : 25cm Once for four surfaces, two sides, one corner	

note) · The test (1) is performed at the backlight on condition.

Lamp current is 7.0mA.

· The test (2) ~ (11) is performed at the backlight off condition.

· The test (3) is performed at non dew condensed condition.

· Judgment is performed after one hour exposure at room temperature after test.

9 .Serial number label

(1) Position and sticking

Label is stuck to the place displayed as below.

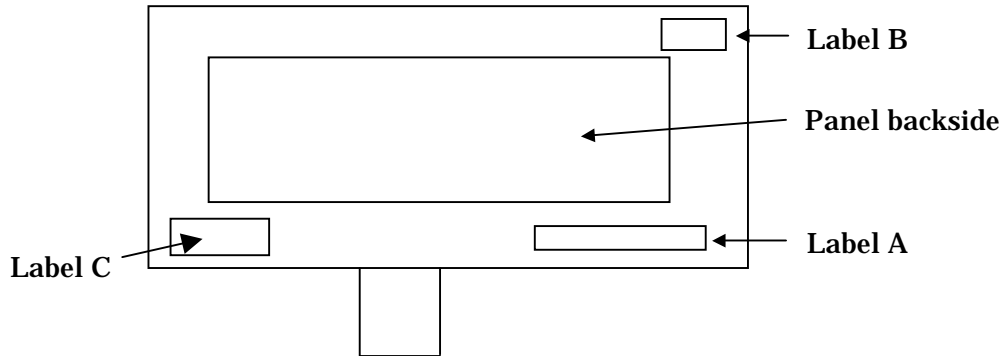

(2)Display contents

1)Label A

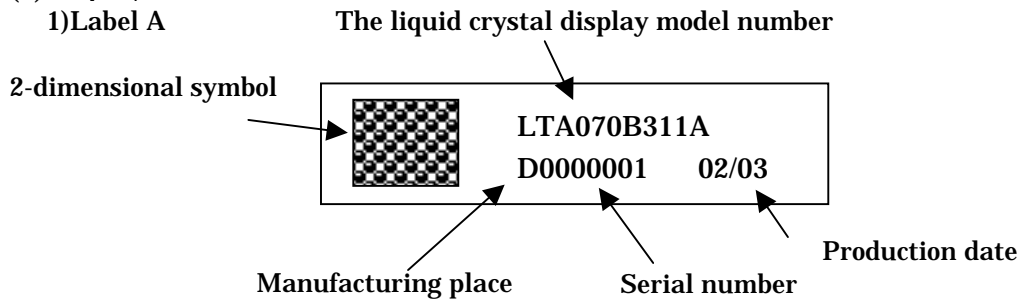

Serial number . . . This is described by a number of six figures beginning with 1
 (ex) 1st 000001

~
 158th 000158

The delivered device doesn't always have a successive serial number.
 The display of manufacturing place is as follows according to the mark before serial number.

- a) A : Aichi
- b) D : Utsunomiya

Product year and month . . . This means the year and month of the LCD device production.
 (ex) 2002 November 02/11

2) Label B



3) Label C : Backlight lot label

10. The Package Specification

- (1) The LCD device is put into the packing bag with anti - electrostatics treatment , and then it is put into the outer case at the condition that the maximum quantity is 30.
- (2) Below mentioned contents are directly printed on the outer case , or the label which describes below mentioned contents is stuck to the outer case.

Customer	
Cust. Part. No.	
Part. No.	LTA070B311A
Quantity	(EX) 30
Lot No.	(EX) 02.11.15

(3)The drawing for packaging

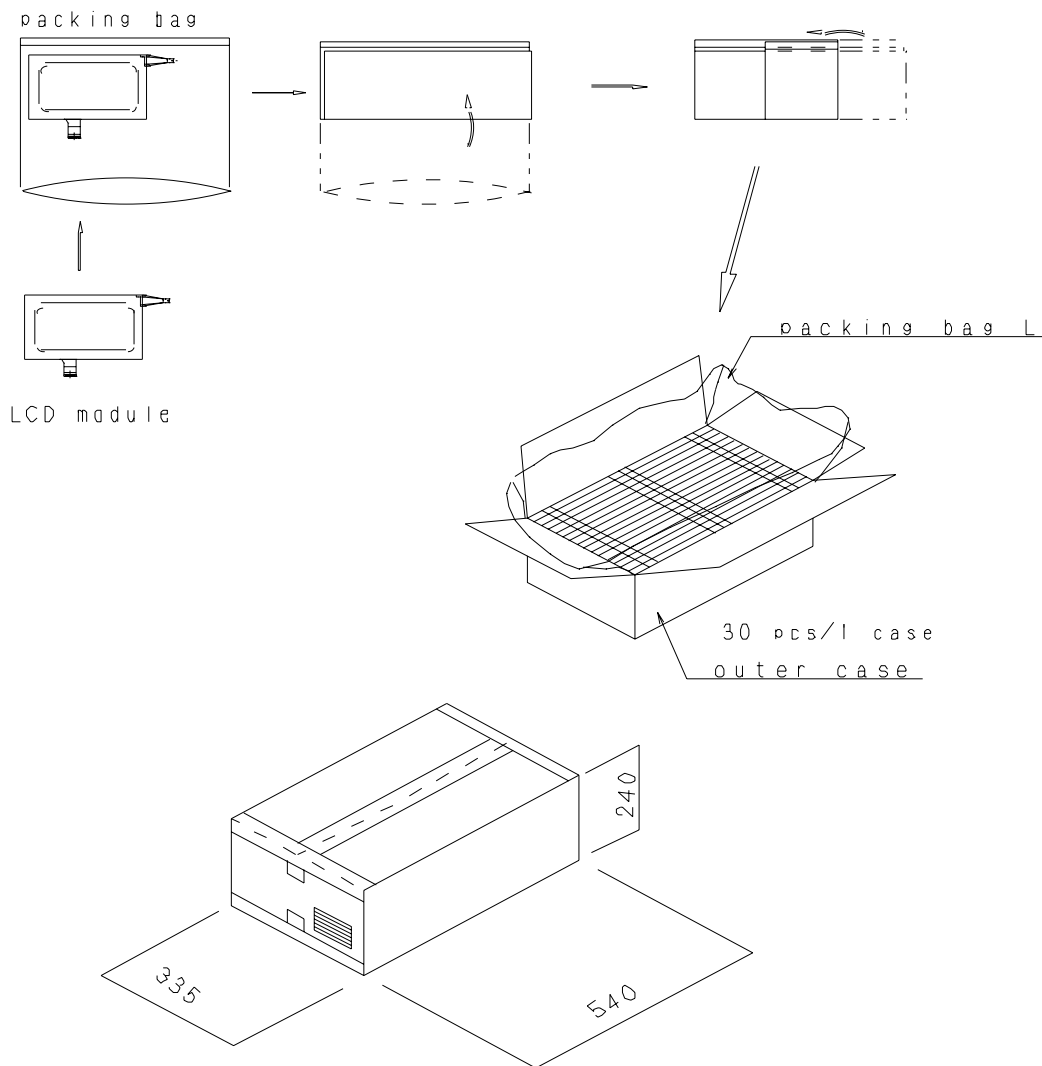

Caution and Handling Precaution

For your end user's safety, it is strongly advised that the items with " " should be included in the instruction manual of the system which may be issued by your organization.

For Safety

Warning

- (1) Toshiba's Standard LCD modules have not been customized for operation in extreme environments or for use in applications where performance failures could be life-threatening or otherwise catastrophic. Since they must never be installed in aircraft navigation control systems (such as, but not limited to Traffic Collision System and Air Traffic Indicator), in military defense or weapons systems, in critical industrial process-control systems (e.g., those involved in the production of nuclear energy), or in critical medical device or patient life-support systems.
- (2) DISCONNECT POWER SUPPLY before handling LCD module.
DO NOT TOUCH the parts inside LCD module and the fluorescent lamp's (hereinafter called "FL") connector or cable in order to prevent electric shock, because high voltage is supplied to these parts from the inverter unit while power supply is turned on.
- (3) Make sure to insert the module FL connector to the inverter connector in correct position. If incorrect, this may cause smoke or burn of electrical parts by high voltage of FL circuit. If there is a possibility that the connector has been inserted incorrectly, please re-insert the connector only after you confirm the module and FL power is completely off.
DO NOT USE the mating FL connector which Toshiba does not specify. Otherwise, Toshiba shall not be liable for any damages caused by the connector.

Caution

- (1) DO NOT DISASSEMBLE OR MODIFY the module.
Sensitive parts inside LCD module may be damaged, and dusts or scratches may mar the displays. Toshiba does not warrant the module, if customer disassembled or modified them.
- * (2) DO NOT INGEST liquid crystal material, DO NOT INHALE this material, and DO NOT PERMIT this material to contact the skin, if LCD panel is broken and liquid crystal material spills out.
In the event of inadvertent contact, immediately rinse the mouth or eyes with adequate water.
If this material should inadvertently contact the skin or clothing, wash immediately with alcohol and then rinse thoroughly with water.
- * (3) BE CAREFUL WITH CHIPS OF GLASS that may cause injuring fingers or skin, when the glass is broken.
- (4) DO NOT EXCEED the absolute maximum rating values under the worst probable conditions caused by the supply voltage variation, input voltage variation, variation in parts constants, ambient temperature, etc., otherwise LCD module may be damaged.
- (5) Suitable protection circuit should be applied for each system design.
DO NOT MODIFY the fuse used in the module. It may cause overheat and/or burning if dusts or metal particles are on the PCBs in the LCD module.
- (6) Always comply all applicable environmental regulations, when disposing of LCD module.

For Designing the System

- (1) LCD module should be assembled to the system by using all mounting holes specified in the this specification and with the specified screws.
- (2) Power supply lines should be designed as follows.

Power supplies should always be turned on before the input signals are supplied to LCD module, and the input signals should be disconnected before power supplies are turned off.
- (3) Make sure to connect correctly high-voltage wire and low-voltage wire between FL tube and inverter unit.
- (4) Input FL starting voltage should be longer than one second. If it were not, it may cause unstable operation of FL.
- (5) In case of severe environmental condition like outdoor usage, a proper transparent protective cover over LCD module is recommended to apply in order to prevent scratches, and invasion of dusts, water, etc., from the system's window onto LCD module.

Ultra-violet ray cut filter is recommended to apply onto LCD module for outdoor operation. Strong ultra-violet ray may cause damage the panel.

For Installation in Assembly

- (1) The C-MOS LSIs used in LCD module are very sensitive to ESD (electro-static Discharge). Ambient humidity of working area is recommended to be higher than 50%RH.

Person handling LCD modules should be grounded with wrist band. Tools like soldering iron and screw driver, and working benches should be grounded.

The grounding should be done through a resistor of 0.5-1M ohms in order to prevent spark of ESD.
- (2) When remove protection film from LCD panel, peel off the film slowly (more than three seconds) from the edge of the panel, using a soft-pointed tweezers covered by teflon or adherent tape.
- (3) Reduce dust level in working area. Especially the level of metal particle should be decreased.

Use finger stalls or soft and dust-free gloves in order to keep clean appearance of LCD module when handled for incoming inspection and assembly.
- * (4) When LCD panel becomes dirty, wipe off the panel surface softly with absorbent cotton or another soft cloth.

If necessary, breathe upon the panel surface and then wipe off immediately and softly again.

If the dirt can not be wiped off, absorbent cotton wetted a little with GALDEN (product name) can be used for wiping the panel.

Be careful not to spill this solvent into the inside of LCD module. Driver ICs and PCB area used inside LCD module may be damaged by the solvent.
- * (5) AVOID THE DEWING OF WATER CONDENSATION.

Wipe off a spot or spots of water of mist on LCD panel softly with absorbent cotton or another cloth as soon as possible if happened, otherwise discoloration or stain may be caused. If water invade into LCD module, it may cause LCD module damages.
- * (6) DO NOT APPLY MECHANICAL FORCES.

Do not bend or twist LCD module even momentary when LCD module is installed an enclosure of the system. Bending or twisting LCD module may cause its damages. Make sure to design the enclosure that bending/twisting forces are not applied to LCD module when it is installed in the system.

Refrain from strong mechanical shock like dropping from the working bench or knocking against hard object. These may cause the panel crack, damage of FL or other mis-operation.
- * (7) Refrain from excessive force like pushing the surface of LCD panel. This may cause damage of the panel or electrical parts on PCB.

*(8) Do not put heavy object such as tools, books, etc., and do not pile up LCD modules.

Be careful not to touch surface of the polarizer laminated to the panel with any hard and sharp object. The polarizer is so soft that it can be easily scratched, even the protect film covers it.

(9) When inserting or disconnecting the connectors to LCD module, be sure not to apply force against PCB, not connecting cables, otherwise internal connection of PCB and TAB drivers may be damages.

Do not fasten screws with catching interface cables or FL cables between LCD module and the enclosure.

These may cause bending of LCD module, or damaging cable insulating cover.

(10) Be careful not to pull the FL cables in order to avoid mechanical damage in FL lamp and soldering area.

(11) Power supplies should always be turned off in assembling process.

Do not connect or disconnect the power cables and connectors with power applied to LCD module.

This may cause damage of module circuit.

The signal should be applied after power supplies are turned on. And the signal should be removed before power supplies are turned off.

For Transportation and Storage

(1) Do not store LCD module in high temperature, especially in high humidity for a long time approximately more than one month).

It is recommended to store LCD module where the temperature is in the range of 0 to 35 degrees Celsius and the relative humidity is lower than 70%.

(2) Store LCD module without exposure to direct sunlight or fluorescent lamps in order to prevent the module from strong ultra violet ray.

*(3) Avoid condensation of water on LCD module, otherwise it may cause mis-operation or defects.

Keep away LCD module from such ambient.

(4) In case of transportation of storage after opening the original packing. LCD module are recommended to be repacked into the original packaging with the same method, especially with same kind of desiccant.

