

ELECTRONICS

DATE : December. 1, 2005

SAMSUNG TFT-LCD

**MODEL NO. : LTA120W1-T01**

NOTE :

Any Modification of Spec is not allowed without SEC's permission.

APPROVED BY : S.C.OH

PREPARED BY : Mobile Display Development Team, AMLCD Division

**SAMSUNG ELECTRONICS CO., LTD.**

Doc.No.	LTA120W1-T01	Rev.No	05 - 000 - G - 051201	Page	1 /25
---------	--------------	--------	-----------------------	------	-------

## CONTENTS

General Description	----- ( 3 )
1. Absolute Maximum Ratings	----- ( 4 )
1.1 Absolute Ratings Of Environment	
1.2 Electrical Absolute Ratings	
2. Optical Characteristics	----- ( 6 )
3. Electrical Characteristics	----- ( 9 )
3.1 TFT LCD Module	
3.2 Back-light Unit	
4. Block Diagram	----- ( 11 )
4.1 TFT LCD Module	
4.2 Back-light Unit	
5. Input Terminal Pin Assignment	----- ( 12 )
5.1 Input Signal & Power	
5.2 Back-light Unit	
5.3 Input Signals, Basic Display Colors and Gray Scale of Each Color.	
5.4 Pixel format	
5.5 Display Direction Signal	
6. Interface Timing	----- ( 16 )
6.1 Timing Parameters	
6.2 Timing Diagrams of interface Signal	
6.3 Power ON/OFF Sequence	
7. Outline Dimension	----- ( 20 )
8. General Precautions	----- ( 21 )
9. Packing	----- ( 23 )
10. Marking & Others	----- ( 24 )

Doc.No.	LTA120W1-T01	Rev.No	05 - 000 - G - 051201	Page	2 /25
---------	--------------	--------	-----------------------	------	-------

## GENERAL DESCRIPTION

### DESCRIPTION

LTA120W1-T01 is a color active matrix TFT (Thin Film Transistor) liquid crystal display (LCD) that uses amorphous silicon TFT as a switching devices. This model is composed of a TFT LCD panel, a driver circuit and a back-light system. The resolution of a 10.0 " contains 800 x 480 pixels and can display up to 262,144 colors. 6 o'clock direction is the optimum viewing angle.

### FEATURES

- Thin and light weight
- High contrast ratio, Wide view angle, High-speed response
- Wide VGA (800x480 pixels) resolution
- Low power consumption
- Single CCFL(Cold Cathode Fluorescent Light)

### APPLICATIONS

- Notebook PC and desktop monitors
- Display terminals for AV application products
- Monitors for Industrial machine

### GENERAL INFORMATION

ITEM	SPECIFICATION	UNIT	NOTE
Display area	261.6(H) x 156.96(V) (12.0" diagonal )	mm	A/R=15:9
Driver element	a-Si TFT active matrix		
Display colors	262,144		
Number of pixel	800(R,G,B) x 480 (Wide VGA)	pixel	
Pixel arrangement	RGB vertical stripe		
Pixel pitch	0.3270(H) x 0.3270(V) (TYP.)	mm	
Display Mode	Normally white		

Doc.No.	LTA120W1-T01	Rev.No	05 - 000 - G - 051201	Page	3 /25
---------	--------------	--------	-----------------------	------	-------

## MECHANICAL INFORMATION

ITEM		MIN.	TYP.	MAX.	NOTE
Module size	Horizontal (H)	282.5	283.0	283.5	
	Vertical (V)	172.5	173.0	173.5	
	Depth (D)		6.3	6.6	
Weight		-	-	520	

## 1. ABSOLUTE MAXIMUM RATINGS

## 1.1 ABSOLUTE RATINGS OF ENVIRONMENT

ITEM	SYMBOL	MIN.	MAX.	UNIT	NOTE
Storage temperature	$T_{STG}$	-25	60	°C	(1)
Operating temperature (Temperature of glass surface)	$T_{OPR}$	0	50	°C	(1) Lamp Current =6.0mA

Note (1) Temperature and relative humidity range are shown in the figure below.

95 % RH Max. (  $40\text{ }^{\circ}\text{C} \geq T_a$  )

Maximum wet - bulb temperature at  $39\text{ }^{\circ}\text{C}$  or less. (  $T_a > 40\text{ }^{\circ}\text{C}$  ) No condensation.

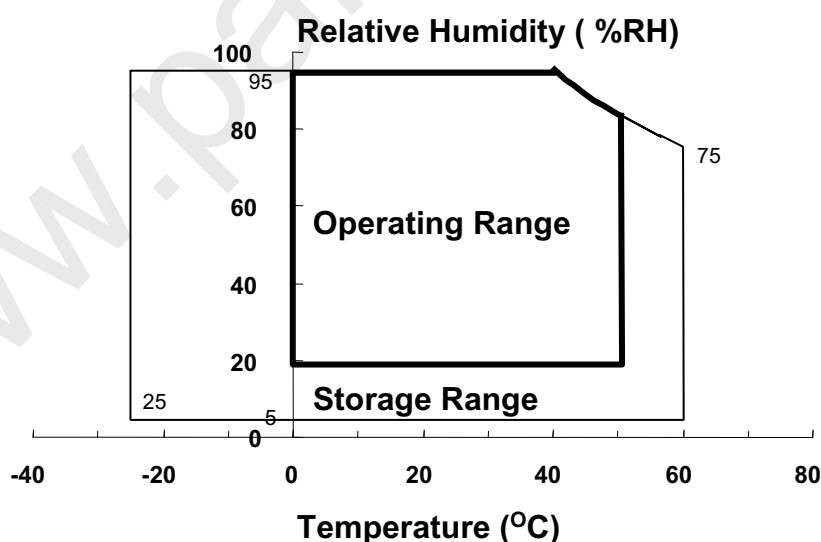

## 1.2 ELECTRICAL ABSOLUTE RATINGS

## (1) TFT LCD MODULE

ITEM	SYMBOL	MIN.	MAX.	UNIT	NOTE
Power Supply Voltage	DVDD	-0.3	7.0	V	
Power Supply Voltage	AVDD	-0.3	7.0	V	
Gate IC Voltage (+)	VGG	-0.3	VEE+45	V	
Gate IC Voltage(-)	VEE	DVDD-42	-0.3	V	
Gate IC Voltage	VGG-VEE	-	42	V	
Logic Input Voltage	VIND	-0.3	DVDD+0.3	V	
Analog Input Voltage	VINA	-0.3	AVDD+0.3	V	GAM1~11

## (2) BACK-LIGHT UNIT

Ta = 25 ± 2 °C

ITEM	SYMBOL	MIN.	TYP	MAX.	UNIT.	NOTE
Lamp current	IL	3.0	-	7.0	mArms	
Lamp frequency	fL	40		60	KHz	(1)
		40		80		(2)

NOTE (1) Electrical-optical characteristics is ± 10 % can be guaranteed.

(2) Life time and reliability can be guaranteed.

## 2. OPTICAL CHARACTERISTICS

The following items are measured under stable conditions. The optical characteristics should be measured in a dark room or equivalent state with the methods shown in Note (5).

Measuring equipment : TOPCON BM-5A

\* Ta = 25 ± 2°C , fv= 60Hz, f<sub>DCLK</sub>=32MHz, IL = 6.0 mA

ITEM		SYMBOL	CONDITION	MIN.	TYP.	MAX.	UNIT	NOTE
Contrast Ratio (5 Points)		CR		-	300	-		(1), (2)
Response Time at Ta	Rising	T <sub>R</sub>		-	10	15	msec	(1), (3)
	Falling	T <sub>F</sub>		-	20	25		
Average Luminance of White (5 Points)		Y <sub>L,AVE</sub>	$\phi = 0,$	-	350	-	cd/m <sup>2</sup>	(4) 6.0mA <sub>rms</sub>
Color Chromaticity ( CIE 1931 )	Red	R <sub>X</sub>	$\theta = 0$	0.566	0.596	0.626	Measured by PR 650	(1), (5)
		R <sub>Y</sub>	Normal Viewing Angle	0.311	0.341	0.371		
	Green	G <sub>X</sub>		0.286	0.316	0.346		
		G <sub>Y</sub>		0.497	0.527	0.557		
	Blue	B <sub>X</sub>		0.123	0.153	0.183		
		B <sub>Y</sub>		0.109	0.139	0.169		
	White	W <sub>X</sub>		0.287	0.317	0.347		
		W <sub>Y</sub>	0.302	0.332	0.362			
Viewing Angle	Hor.	$\theta_L$	CR( at center point) ≥ 10	-	60	-	Degrees	(1),(5)
		$\theta_R$		-	60	-		
	Ver.	$\phi_H$		-	45	-		
		$\phi_L$		-	45	-		

Note 1) Definition of Viewing Angle : Viewing angle range( $10 \leq C/R$ )

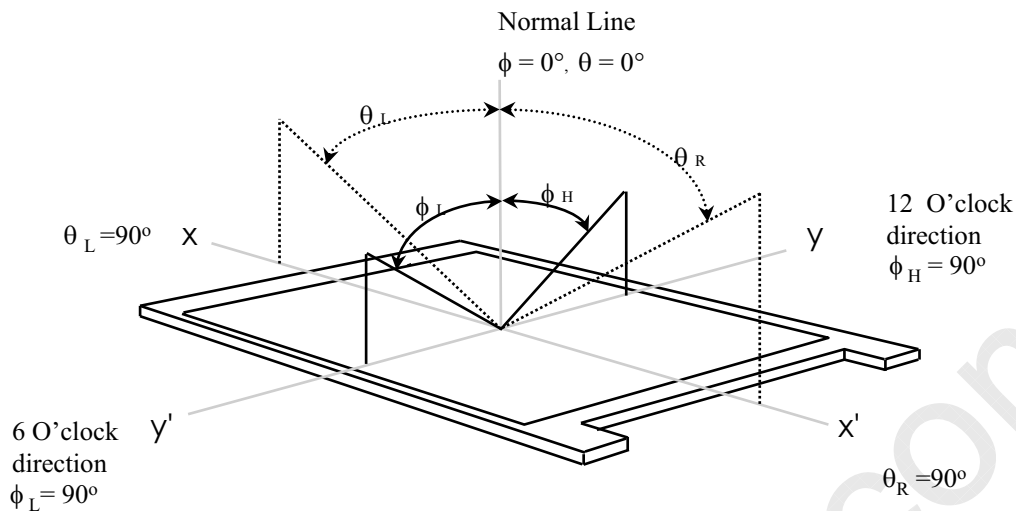

Note 2) Definition of Contrast Ratio (CR) : Ratio of gray max (Gmax) ,gray min (Gmin) at 5 points(1, 3, 5, 7, 9)

$$CR = \frac{CR(1) + CR(3) + CR(5) + CR(7) + CR(9)}{5}$$

POINTS : (1) , (3) , (5) , (7) , (9) at FIGURE OF NOTE 4)

Note 3) Definition of Response time :

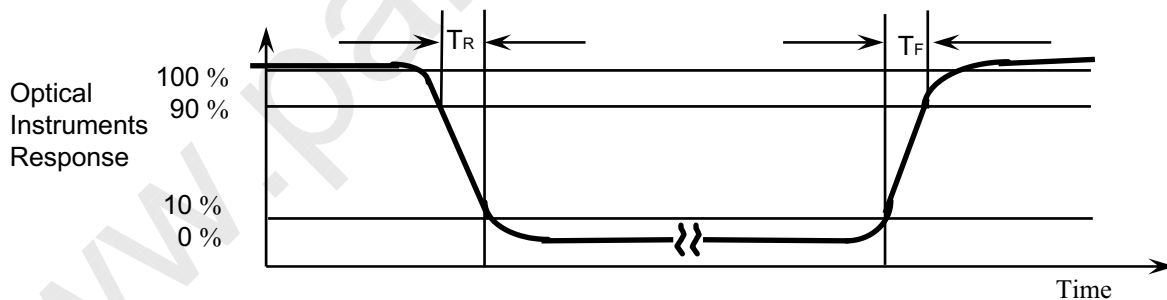
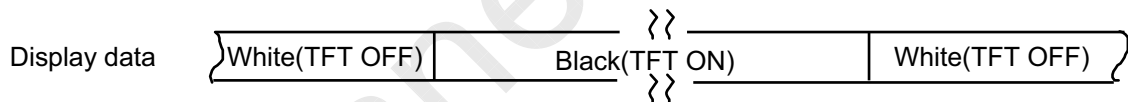

Note 4) Definition of Average Luminance of White : measure the luminance of white at 5 points.

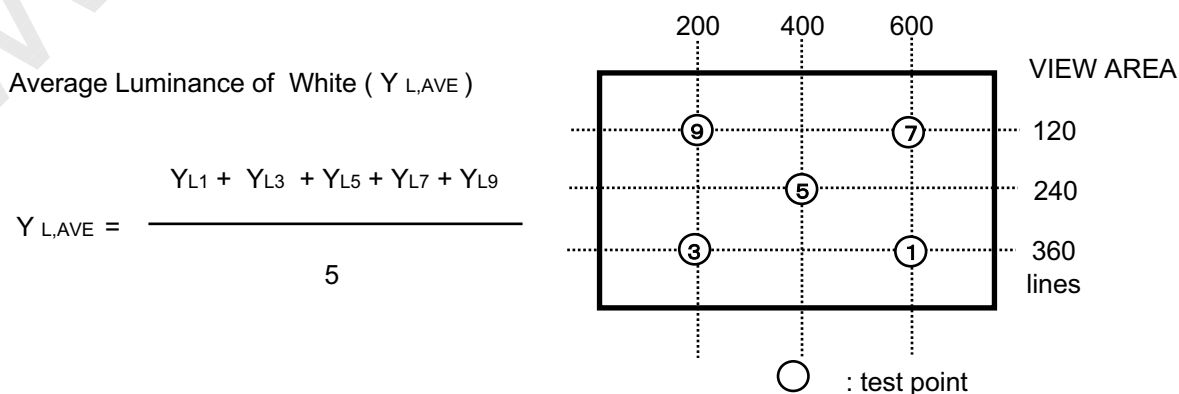

Note 5) After stabilizing and leaving the panel alone at a given temperature for 30 minutes, the measurement should be executed. Measurement should be executed in a stable, windless, and dark room. 30 minutes after lighting the back-light. This should be measured in the center of screen.

Lamp current : 6.0 mA

Environment condition :  $T_a = 25 \pm 2 \text{ }^\circ\text{C}$

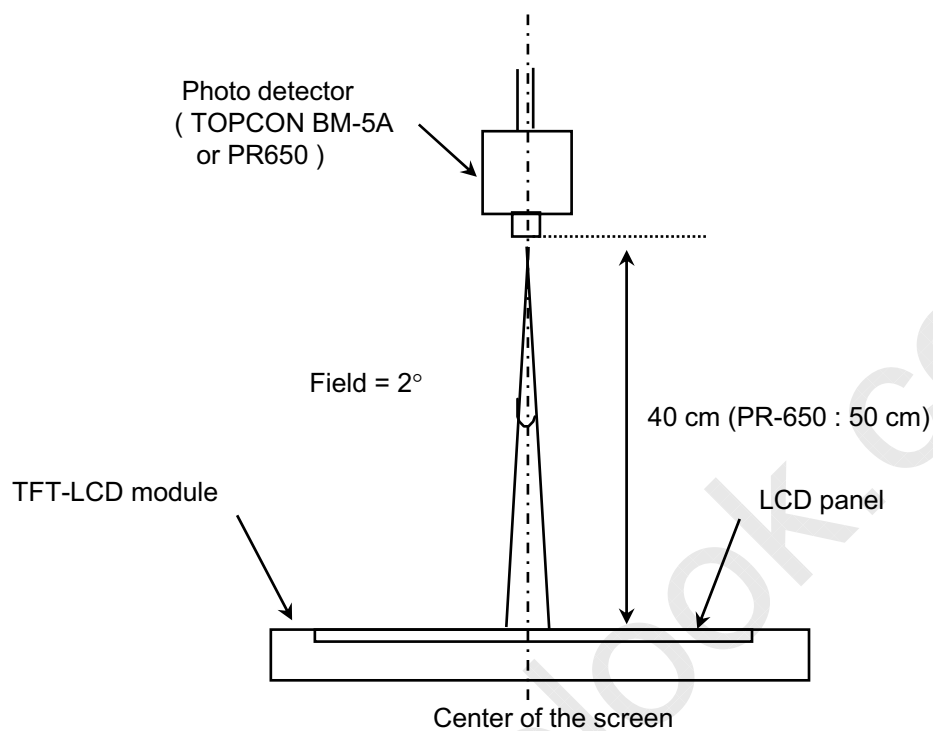

Optical characteristics measurement setup

Doc.No.	LTA120W1-T01	Rev.No	05 - 000 - G - 051201	Page	8 /25
---------	--------------	--------	-----------------------	------	-------



### 3. ELECTRICAL CHARACTERISTICS

#### 3.1 TFT LCD MODULE

 $T_a=25\pm 2\text{ }^{\circ}\text{C}$ 

ITEM		SYMBOL	MIN	TYP	MAX	UNIT	NOTE	
Voltage of Power Supply		DVDD	3.0	3.3	3.6	V		
		AVDD	—	5.0	—	V		
		VGG	—	20	—	V		
		VEE	DC	—	-9.5	—	V	
			AC	—	5	—	Vp-p	
Input Voltage for Logic signals	High	VIH	$0.7 \times DVDD$	—	DVDD	V		
	Low	VIL	0	—	$0.3 \times DVDD$	V		
Input Reference Voltage		VREF	0.1	—	$AVDD-0.1$	V	(1)	
Common Voltage	AC	VCOM	—	5.1	—	Vp-p		
	DC		—	2.2	—	V		
Current of Power Supply (2)		IDV	—	5	10	mA	DVDD=3.3V	
		IAV	—	30	50	mA	AVDD=5.0V	
		IGG	—	0.2	1.0	mA	VGG=20V	
		IEE	—	0.2	1.0	mA	VEE=-12V	

Note (1) Reference voltage should be adjusted depend on VCOM inversion.

Gamma 1 is the opposite phase with VCOM but Gamma11 is same with it .

(2) The Display pattern is white pattern.

### 3.2 BACKLIGHT UNIT

The back-light system is an edge - lighting type with a single CCFT ( Cold Cathode Fluorescent Tube ). The characteristics of a single lamp are shown in the following tables.

INVERTER : SEM SIC-130T

Ta = 25 ± 2°C

ITEM	SYMB	MIN	TYP	MAX	UNIT	NOTE
Lamp Current	I <sub>L</sub>	3.0	6.0	7.0	mArms	(1)
Lamp Voltage	V <sub>L</sub>	-	920	-	V <sub>rms</sub>	(1)
Lamp Frequency	f <sub>L</sub>	40	-	60	KHz	(2)
Power Consumption	P <sub>L</sub>	-	5.52	-	W	(3)
Operating Life Time	H <sub>r</sub>	10,000	-	-	Hour	(4)
Startup Voltage	V <sub>s</sub>	-	-	1560 (25°C)	V <sub>rms</sub>	(5)
				2030 (0°C)		

**Note) The waveform of the inverter output voltage must be area symmetric and the design of the inverter must have specifications for the modularized lamp.**

The performance of the back-light, for example life time or brightness, is much influenced by the characteristics of the DC-AC inverter for the lamp. So all the parameters of an inverter should be carefully designed so as not to produce too much leakage current from high-voltage output of the inverter. When you design or order the inverter, please make sure that a poor lighting caused by the mismatch of the back-light and the inverter(miss lighting, flicker, etc.) never occur. When you confirm it, the module should be operated in the same condition as it is installed in your instrument.

Note (1) Lamp current is measured with a high frequency current meter as shown below.

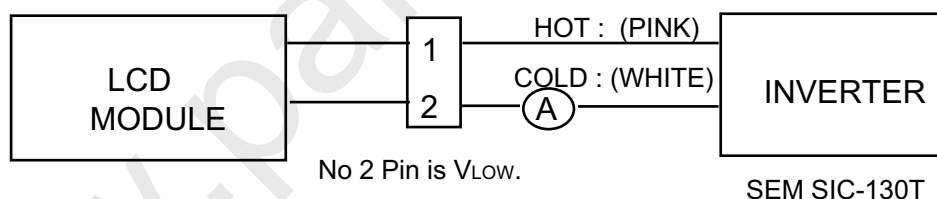

(2) Lamp frequency may produce interference with horizontal synchronous frequency and this may cause line flow on the display. Therefore lamp frequency should be detached from the horizontal synchronous frequency and its harmonics as far as possible in order to avoid interference.

(3) refer to I<sub>L</sub> X V<sub>L</sub> to calculate.

(4) Life time (Hr) of a lamp can be defined as the time in which it continues to operate under the condition Ta = 25 ± 2°C and I<sub>L</sub> = 6.0 mArms until one of the following event occurs.

1. When the brightness becomes 50% or lower than it's original.
2. When the Effective ignition length becomes 80% or lower than it's original value.  
(Effective ignition length is defined as an area that has less than 70% brightness compared to the brightness in the center point.)

(5) The voltage above this value should be applied to the lamp for more than 1 second to startup. Otherwise the lamp may not be turned on.

Doc.No.	LTA120W1-T01	Rev.No	05 - 000 - G - 051201	Page	10/25
---------	--------------	--------	-----------------------	------	-------

## 4. BLOCK DIAGRAM

### 4.1 TFT LCD MODULE

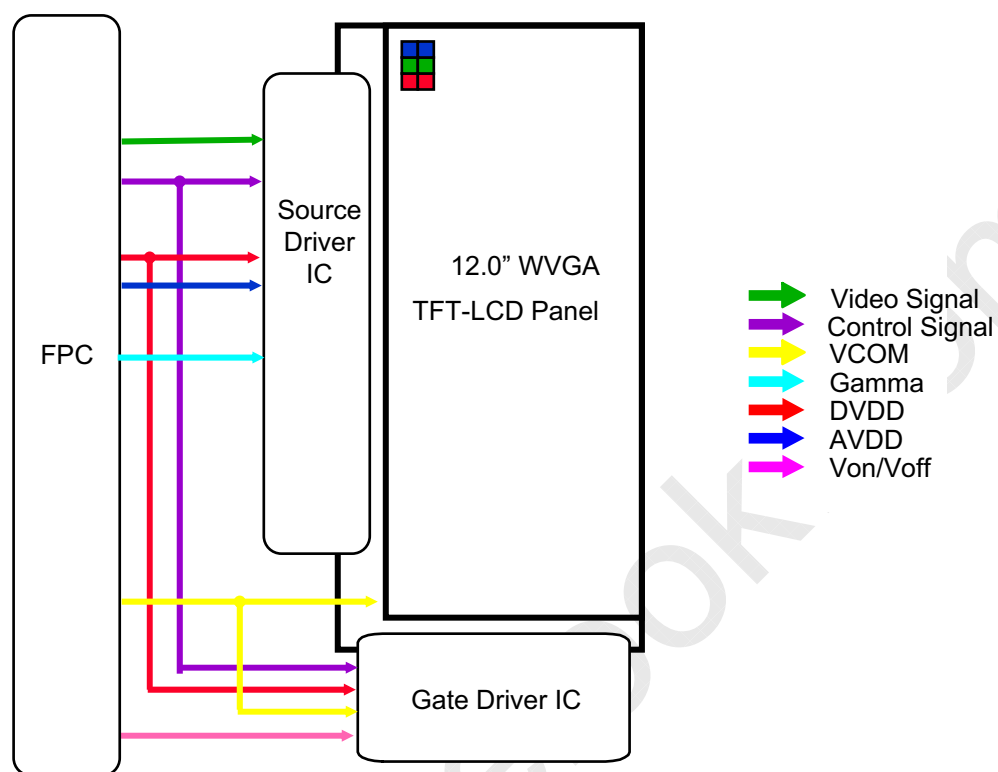

### 4.2 BACKLIGHT UNIT

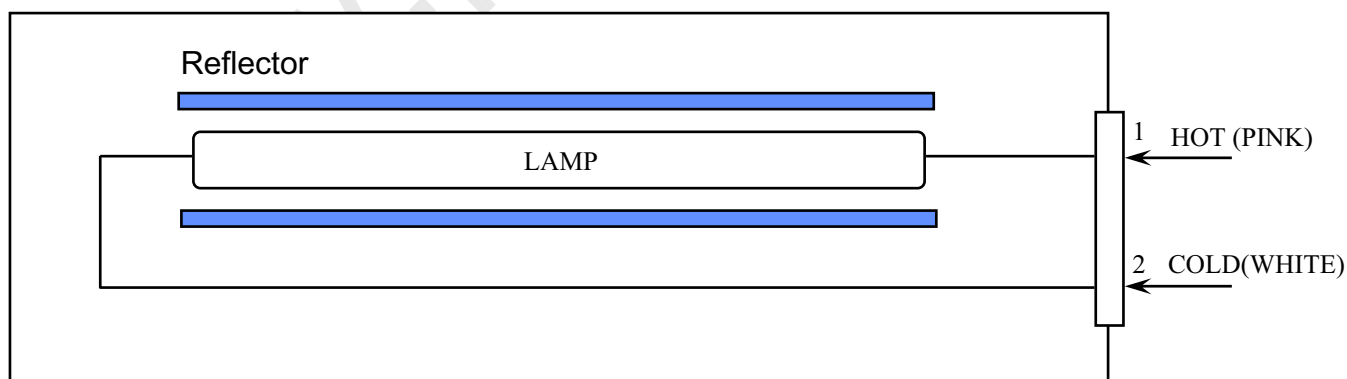

Note) The output of the inverter may change according to the material of the reflector.

## 5. INPUT TERMINAL PIN ASSIGNMENT

### 5.1. Interface Signal & Power (TTL, Connector : UJU FPC 30 pin)

Connector #1 PIN NO	SYMBOL	FUNCTION	Connector #2 PIN NO	SYMBOL	FUNCTION
1	N.C	No Connection	1	GND	Power Ground
2	DIO2	Down Shift Vertical Signal (STV_L)	2	D15	GREEN DATA(MSB)
3	OE	Output Enable	3	D14	GREEN DATA
4	CPV	Vertical Clock Pulse	4	D13	GREEN DATA
5	DIO1	Up Shift Vertical Signal(STV_H)	5	D12	GREEN DATA
6	GND	Power Ground	6	D11	GREEN DATA
7	N.C	No Connection	7	D10	GREEN DATA(LSB)
8	VDD	Power Supply [ +3.3V ]	8	PLSR	Right Shift Horizontal Signal(STH_R)
9	N.C	No Connection	9	INV	POWER GND
10	VOFF	Gate Off Voltage	10	GND	Power Ground
11	N.C	No Connection	11	CLK	Horizontal Clock Pulse
12	VON	Gate On Voltage	12	DVDD	Power Supply [ +3.3V ]
13	N.C	No Connection	13	PRSL	Left Shift Horizontal Signal(STH_L)
14	U/D	DIO1/DIO2 Shift Direction Select	14	TP	Load Output Signal
15	VCOM	Common Voltage	15	D25	BLUE DATA(MSB)
16	GND	Power Ground	16	D24	BLUE DATA
17	AVDD	Power Supply [ +5.0V ]	17	D23	BLUE DATA
18	GAM10	Gamma Voltage 10	18	D22	BLUE DATA
19	GAM8	Gamma Voltage 8	19	D21	BLUE DATA
20	GAM6	Gamma Voltage 6	20	D20	BLUE DATA(LSB)
21	GAM4	Gamma Voltage 4	21	R/L	PLSR/PRSL Shift Direction Select
22	GAM2	Gamma Voltage 2	22	GAM1	Gamma Voltage 1
23	GND	Power Ground	23	GAM3	Gamma Voltage 3
24	D05	RED DATA(MSB)	24	GAM5	Gamma Voltage 5
25	D04	RED DATA	25	GAM7	Gamma Voltage 7
26	D03	RED DATA	26	GAM9	Gamma Voltage 9
27	D02	RED DATA	27	GAM11	Gamma Voltage 11
28	D01	RED DATA	28	AVDD	Power Supply [ +5.0V ]
29	D00	RED DATA(LSB)	29	GND	Power Ground
30	GND	Power Ground	30	VCOM	Common Voltage

## 5.2 BACK LIGHT UNIT

Connector : JST BHSR - 02VS -1  
Mating Connector : JST SM02B-BHSS-1

Pin NO.	Symbol	Color	Function
1	HOT	PINK	High Voltage
2	COLD	WHITE	Low Voltage

www.panelook.com

### 5.3 Input Signal, Basic Display Colors and Gray Scale of Each Colors

COLOR	DISPLAY	DATA SIGNAL															GRAY SCALE LEVEL		
		RED					GREEN					BLUE							
		R0	R1	R2	R3	R4	R5	G0	G1	G2	G3	G4	G5	B0	B1	B2		B3	B4
BASIC COLOR	BLACK	0	0	0	0	0	0	0	0	0	0	0	0	0	0	0	0	0	-
	BLUE	0	0	0	0	0	0	0	0	0	0	0	0	1	1	1	1	1	-
	GREEN	0	0	0	0	0	0	1	1	1	1	1	1	0	0	0	0	0	-
	CYAN	0	0	0	0	0	0	1	1	1	1	1	1	1	1	1	1	1	-
	RED	1	1	1	1	1	1	0	0	0	0	0	0	0	0	0	0	0	-
	MAGENTA	1	1	1	1	1	1	0	0	0	0	0	0	1	1	1	1	1	-
	YELLOW	1	1	1	1	1	1	1	1	1	1	1	1	0	0	0	0	0	-
	WHITE	1	1	1	1	1	1	1	1	1	1	1	1	1	1	1	1	1	-
GRAY SCALE OF RED	BLACK	0	0	0	0	0	0	0	0	0	0	0	0	0	0	0	0	0	R0
	DARK ↑	1	0	0	0	0	0	0	0	0	0	0	0	0	0	0	0	0	R1
		0	1	0	0	0	0	0	0	0	0	0	0	0	0	0	0	0	R2
		:	:	:	:	:	:	:	:	:	:	:	:	:	:	:	:	:	R3~R60
	:	:	:	:	:	:	:	:	:	:	:	:	:	:	:	:	:		
	LIGHT ↓	1	0	1	1	1	1	0	0	0	0	0	0	0	0	0	0	0	R61
		0	1	1	1	1	1	0	0	0	0	0	0	0	0	0	0	0	R62
	RED	1	1	1	1	1	1	0	0	0	0	0	0	0	0	0	0	0	R63
GRAY SCALE OF GREEN	BLACK	0	0	0	0	0	0	0	0	0	0	0	0	0	0	0	0	0	G0
	DARK ↑	0	0	0	0	0	0	1	0	0	0	0	0	0	0	0	0	0	G1
		0	0	0	0	0	0	0	1	0	0	0	0	0	0	0	0	0	G2
		:	:	:	:	:	:	:	:	:	:	:	:	:	:	:	:	:	G3~G60
	:	:	:	:	:	:	:	:	:	:	:	:	:	:	:	:	:		
	LIGHT ↓	0	0	0	0	0	0	1	0	1	1	1	1	0	0	0	0	0	G61
		0	0	0	0	0	0	0	1	1	1	1	1	0	0	0	0	0	G62
	GREEN	0	0	0	0	0	0	1	1	1	1	1	1	0	0	0	0	0	G63
GRAY SCALE OF BLUE	BLACK	0	0	0	0	0	0	0	0	0	0	0	0	0	0	0	0	0	B0
	DARK ↑	0	0	0	0	0	0	0	0	0	0	0	0	1	0	0	0	0	B1
		0	0	0	0	0	0	0	0	0	0	0	0	0	1	0	0	0	B2
		:	:	:	:	:	:	:	:	:	:	:	:	:	:	:	:	:	B3~B60
	:	:	:	:	:	:	:	:	:	:	:	:	:	:	:	:	:		
	LIGHT ↓	0	0	0	0	0	0	0	0	0	0	0	0	1	0	1	1	1	B61
		0	0	0	0	0	0	0	0	0	0	0	0	0	1	1	1	1	B62
	BLUE	0	0	0	0	0	0	0	0	0	0	0	0	1	1	1	1	1	B63

**Note**

(1) Definition of Gray : Rn : Red Gray, Gn : Green Gray, Bn : Blue Gray (n = Gray level)

(2) Input Signal : 0 = Low level voltage, 1 = High level voltage

<b>Doc.No.</b>	<b>LTA120W1-T01</b>	<b>Rev.No</b>	<b>05 - 000 - G - 051201</b>	<b>Page</b>	<b>14/25</b>
----------------	---------------------	---------------	------------------------------	-------------	--------------

### 5.4 PIXEL FORMAT

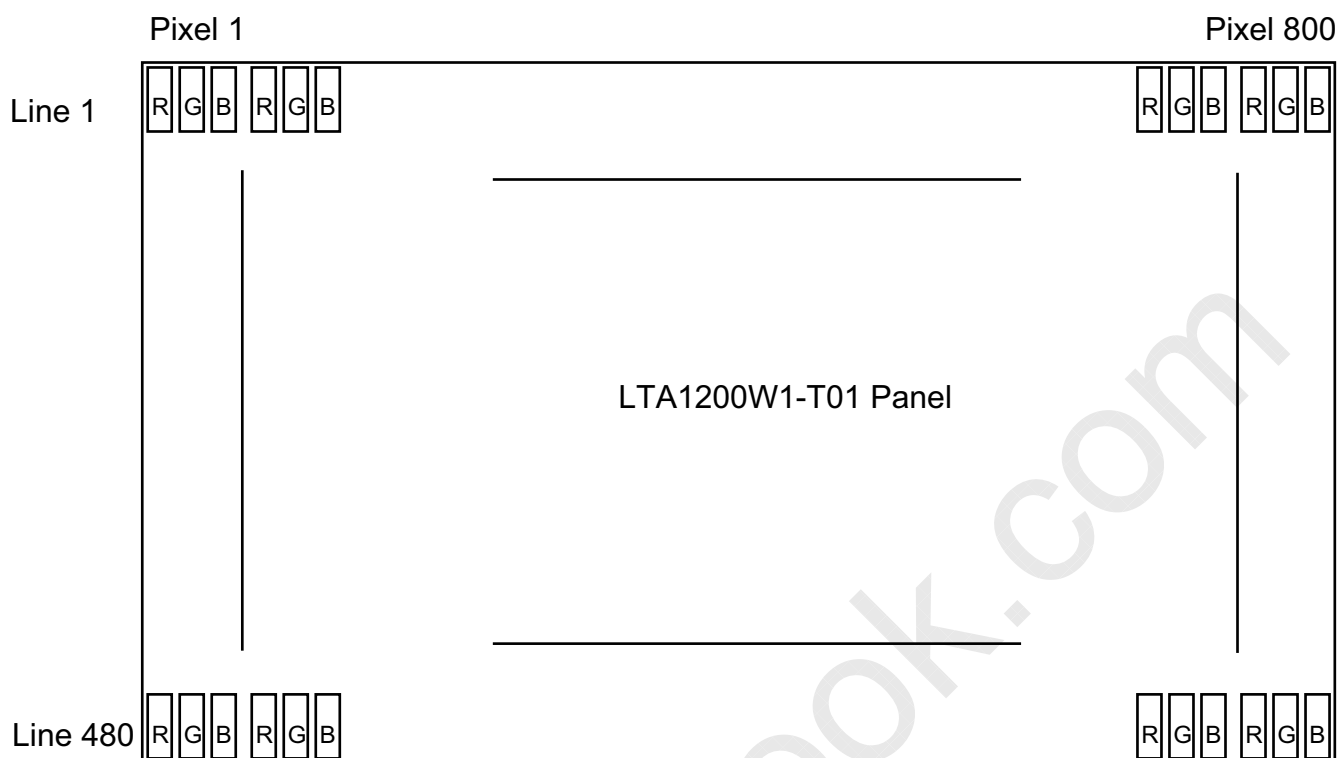

### 5.5 Display Direction Signal

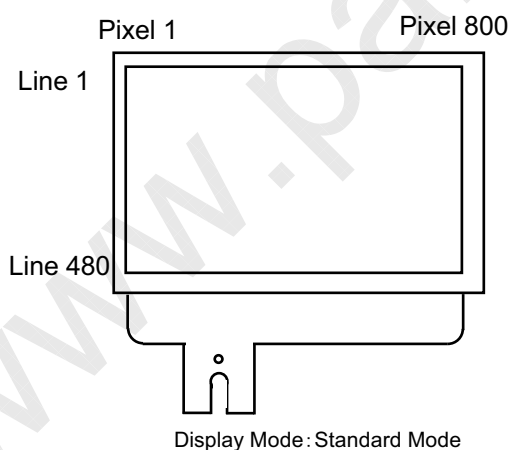

Display Mode	RL	UD
Standard	H	L
RL Reversal	L	L
UD Reversal	H	H
RL/UD Reversal	L	H

## 6. INTERFACE TIMING

### 6.1 Timing Parameters

(Ta=25°C)

	Item	Symbol	MIN	TYP	MAX	Unit
Source	Clock frequency	tp		33.2	40	MHz
	Clock High Time	twcH	5			ns
	Clock Low Time	twcL	5			ns
	Shift Signal	PLSR/PRSL		31.5		kHz
	Data Setup Time	tst1	5			ns
	Data Hold Time	thd1	1			ns
	Shift Signal Setup Time	tst2	5			ns
	Shift Signal Hold Time	thd2	1			ns
	Shift Signal H Time	twsH	1			CLK
	TP-CLK Setup Time	tst4	5			ns
	TP-CLK Hold Time	thd4	1			ns
	Last Data Timing	tng2			1	CLK
	TP Signal H Time	twldH	2			CLK
Gate	Shift Signal	DIO1/DIO2		60		Hz
	CPV Cycle	tcpv	2			μs
	CPV High Time	twH	300			ns
	CPV Low Time	twL	250			ns
	DIO Setup Time	tsu	500			ns
	DIO Hold Time	th	500			ns



### 6.2 Timing diagrams of interface signal

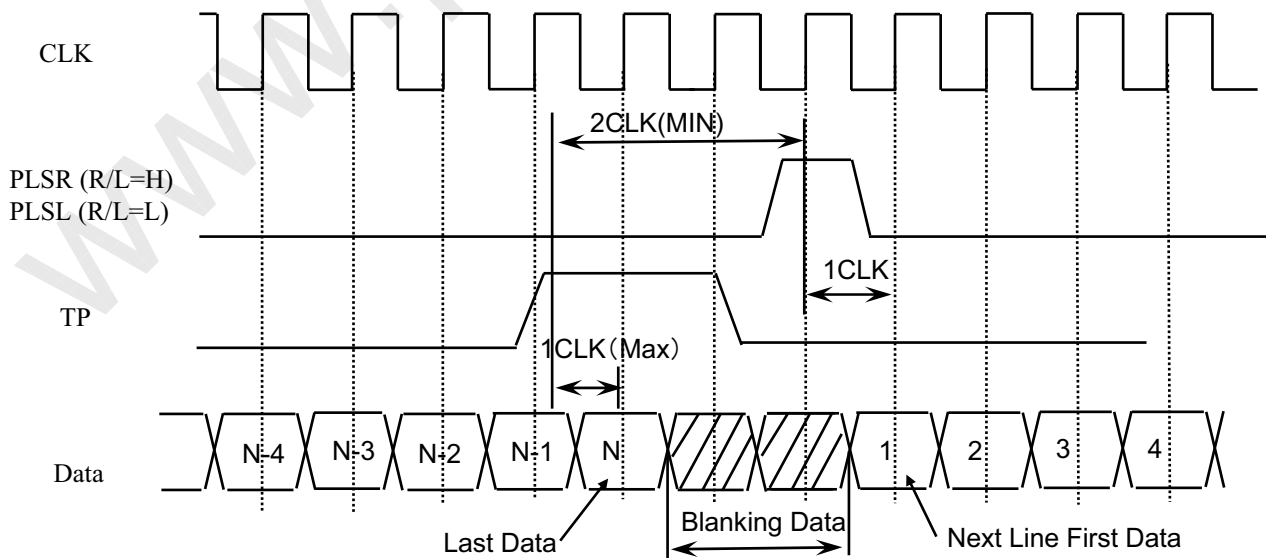
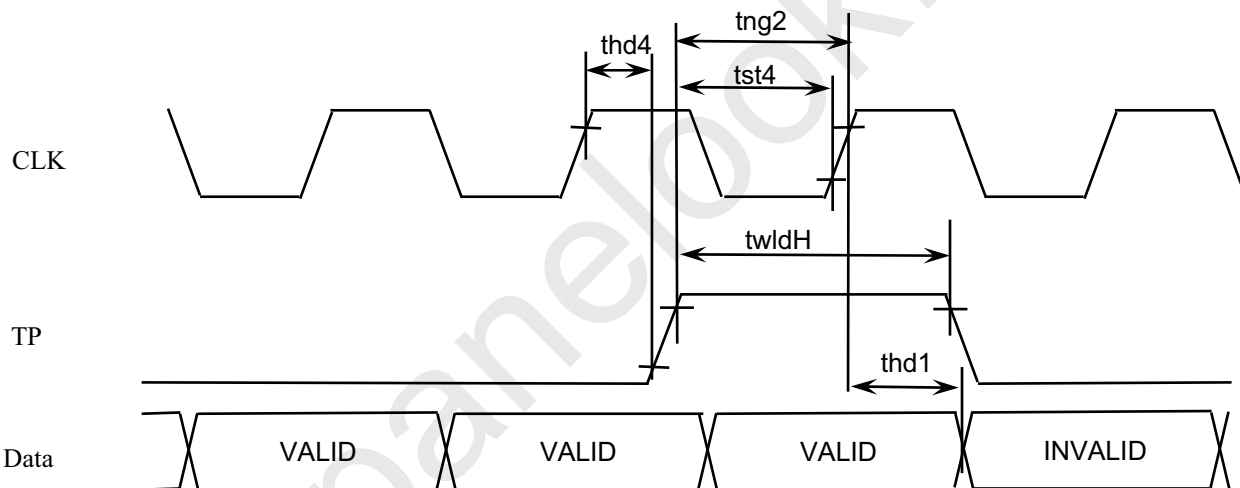
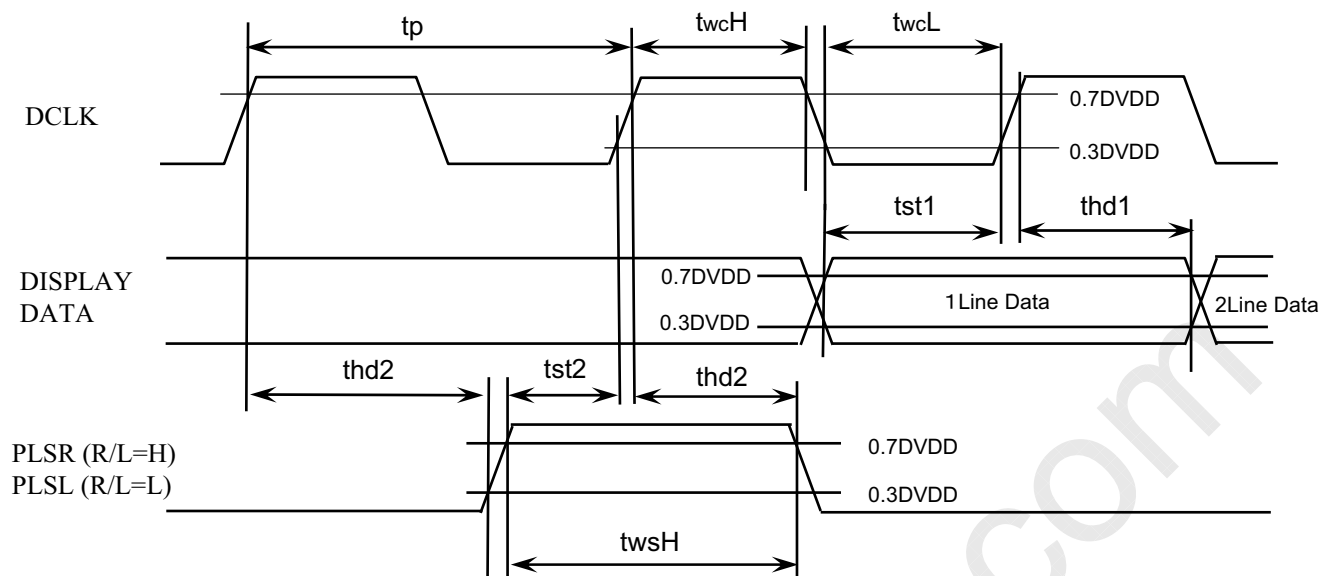

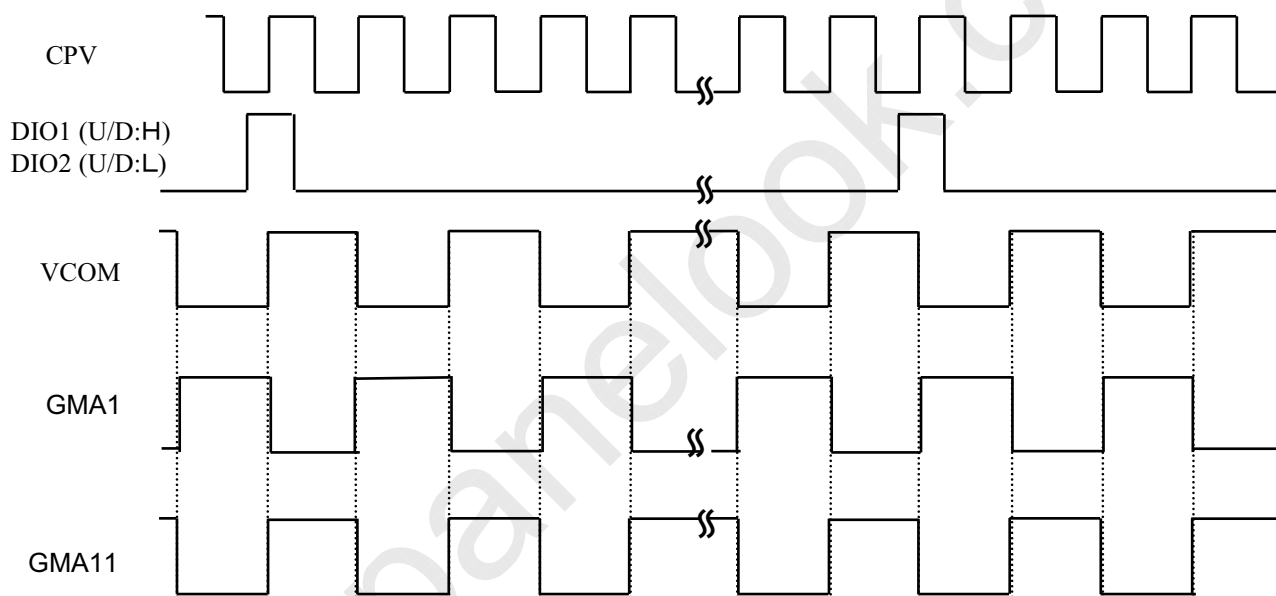
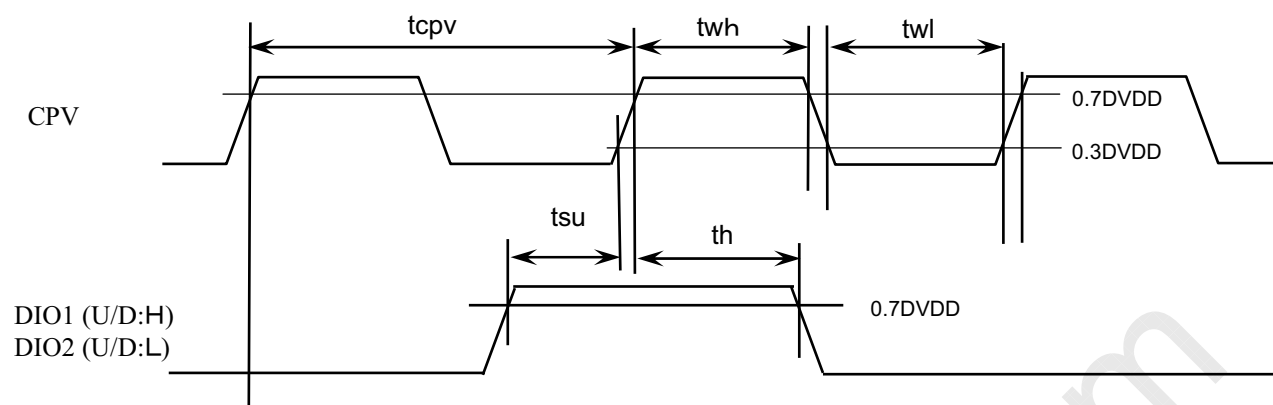

### 6.3 Power ON/OFF Sequence

- To prevent a latch-up or DC operation of the LCD module, the power on/off sequence should be as the diagram below.

-Power On : DVDD → AVDD → VEE → VGG → Data  
 -Power OFF : Data → VGG → VEE → AVDD → DVDD

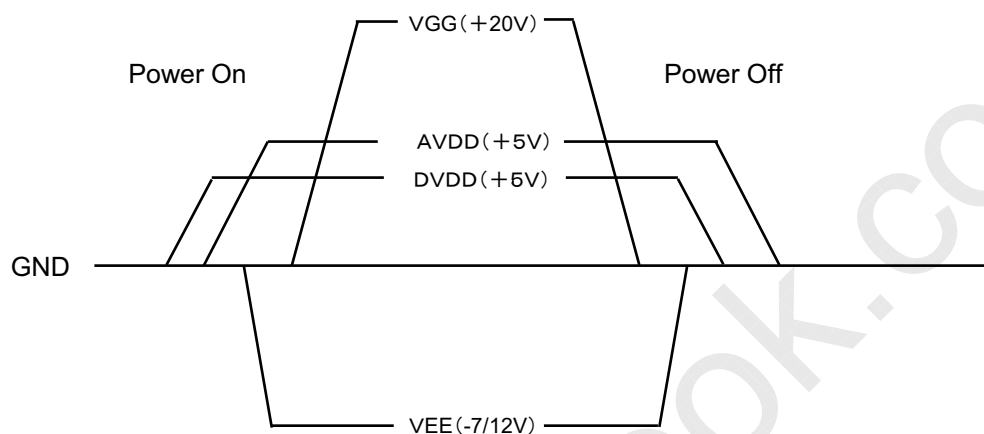

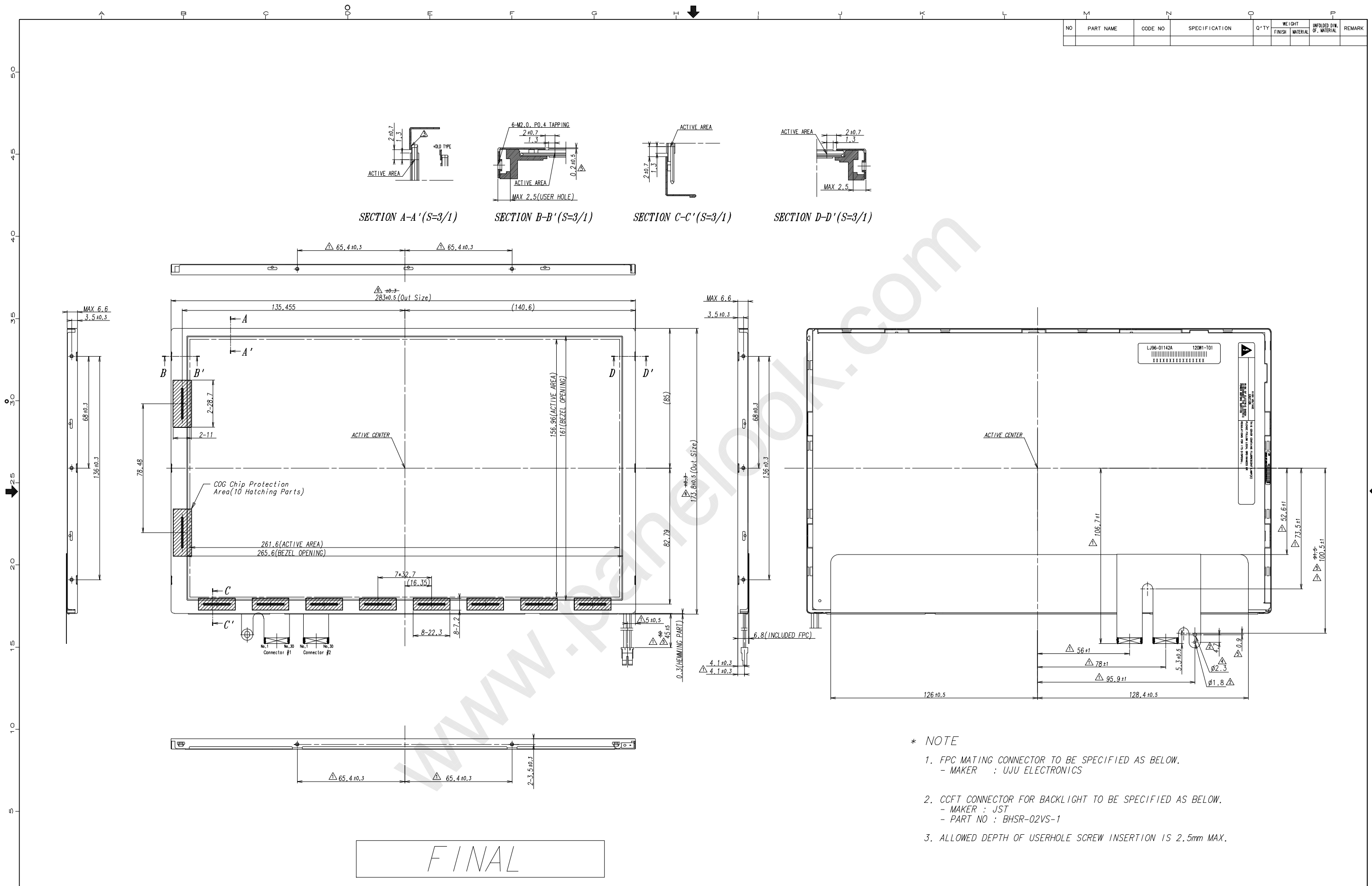

- \* NOTE
- FPC MATING CONNECTOR TO BE SPECIFIED AS BELOW.  
- MAKER : UJU ELECTRONICS
  - CCFT CONNECTOR FOR BACKLIGHT TO BE SPECIFIED AS BELOW.  
- MAKER : JST  
- PART NO : BHSR-02VS-1
  - ALLOWED DEPTH OF USERHOLE SCREW INSERTION IS 2.5mm MAX.

REV	DATE	DESCRIPTION OF REVISION	REASON	CHG'D BY
00	031222	△외관 규차 변경 (±0.3 → ±0.5)	제품 표준 내용과 일치작업	H.S.KIM
00	031104	△Change of Length of Lamp wire(50→45) Etc	Request of Customer	H.S.KIM
00	030828	△ Change of Hole size(R3.5→φ2.3)	Request of Customer	H.S.KIM
00	030403	△ Delete bending on bezel area	pre-counterplan to pooling problem	H.S.KIM
00	030311	△ Add. guide hole on FPC	Request of Customer	H.S.KIM

REV	DATE	DESCRIPTION OF REVISION	REASON	CHG'D BY
00	030310	△Change of location of Lamp Conn & etc	Request of Customer	H.S.KIM

GENERAL TOLERANCE				REV	DATE	DESCRIPTION OF REVISION	REASON	CHG'D BY
STEP	LEVEL 1	LEVEL 2	LEVEL 3	00	030310	△Change of location of Lamp Conn & etc	Request of Customer	H.S.KIM
0 < X ≤ 4	±0.05	±0.1	±0.2	UNIT	mm	DRA'N BY	DES'D BY	CHK'D BY
4 < X ≤ 16	±0.08	±0.15	±0.3	SCALE	1/1	D.C.KIM	Y.B.CHU	APP'D BY
16 < X ≤ 64	±0.12	±0.25	±0.5	TOLERANCE				
64 < X ≤ 256	±0.25	±0.4	±0.8	LEVEL 3				

MODEL NAME	PART/SHEET NAME	SHEET	VER.
LTA120W1-T01	OUTLINE DIMENSION	1/1	00

## 8. GENERAL PRECAUTIONS

### 1. Handling

- (a) When the module is assembled, It should be attached to the system firmly using every mounting holes. Be careful not to twist and bend the modules.
- (b) Refrain from strong mechanical shock and / or any force to the module. In addition to damage, this may cause improper operation or damage to the module and CCFL back-light.
- (c) Note that polarizers are very fragile and could be easily damaged. Do not press or scratch the surface harder than a HB pencil lead.
- (d) Wipe off water droplets or oil immediately. If you leave the droplets for a long time, Staining and discoloration may occur.
- (e) If the surface of the polarizer is dirty, clean it using some absorbent cotton or soft cloth.
- (f) The desirable cleaners are water, IPA(Isoprophyl Alcohol) or Hexane. Do not use Ketone type materials(ex. Acetone), Ethyl alcohol, Toluene, Ethyl acid or Methyl chloride. It might permanent damage to the polarizer due to chemical reaction.
- (g) If the liquid crystal material leaks from the panel, it should be kept away from the eyes or mouth. In case of contact with hands, legs or clothes, it must be washed away thoroughly with soap.
- (h) Protect the module from static, it may cause damage to the C-MOS Gate Array IC.
- (i) Use fingerstalls with soft gloves in order to keep display clean during the incoming inspection and assembly process.
- (j) Do not disassemble the module.
- (k) Do not pull or fold the lamp wire.
- (l) Do not adjust the variable resistor which is located on the back side.
- (m) Protection film for polarizer on the module shall be slowly peeled off just before use so that the electrostatic charge can be minimized.
- (n) Pins of I/F connector shall not be touched directly with bare hands.

Doc.No.	LTA120W1-T01	Rev.No	05 - 000 - G - 051201	Page	21/25
---------	--------------	--------	-----------------------	------	-------

## 2. STORAGE

- (a) Do not leave the module in high temperature, and high humidity for a long time.  
It is highly recommended to store the module with temperature from 0 to 35 °C and relative humidity of less than 70%.
- (b) Do not store the TFT-LCD module in direct sunlight.
- (c) The module shall be stored in a dark place. It is prohibited to apply sunlight or fluorescent light during the store.

## 3. OPERATION

- (a) Do not connect,disconnect the module in the “ Power On” condition.
- (b) Power supply should always be turned on/off by following item 6.3 “ Power on/off sequence “.
- (c) Module has high frequency circuits. Sufficient suppression to the electromagnetic interference shall be done by system manufacturers. Grounding and shielding methods may be important to minimize the interference.
- (d) The cable between the back-light connector and its inverter power supply shall be a minimized length and be connected directly . The longer cable between the back-light and the inverter may cause lower luminance of lamp(CCFT) and may require higher startup voltage(Vs).

## 4. OTHERS

- (a) Ultra-violet ray filter is necessary for outdoor operation.
- (b) Avoid condensation of water. It may result in improper operation or disconnection of electrode.
- (c) Do not exceed the absolute maximum rating value. ( the supply voltage variation, input voltage variation, variation in part contents and environmental temperature, so on)  
Otherwise the module may be damaged.
- (d) If the module displays the same pattern continuously for a long period of time,it can be the situation when the image “sticks” to the screen.
- (e) This module has its circuitry PCB's on the rear side and should be handled carefully in order not to be stressed.

Doc.No.	LTA120W1-T01	Rev.No	05 - 000 - G - 051201	Page	22/25
---------	--------------	--------	-----------------------	------	-------

## 9. Packing

### 9.1 CARTON(Internal Packing)

#### (1) Packing Form

Corrugated fiberboard box and corrugated foam as shock absorber

#### (2)Packing Method

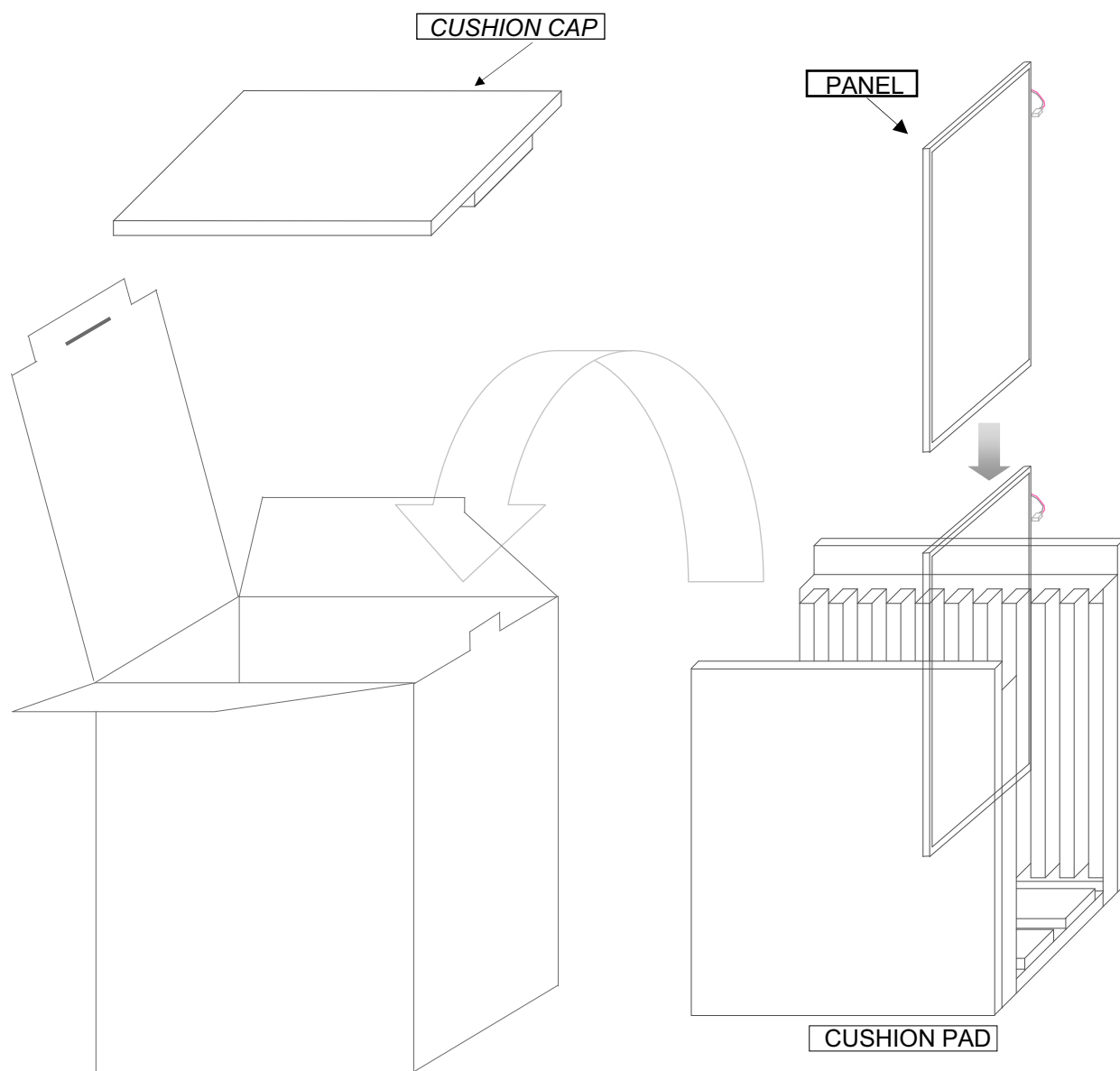

Note (1)Acceptance number of piling : 10 sets

(2)Carton size : 285(W) X 240(D) X 352(H)

**(3)Packing Material**

NO.	Parts name	Quantity
1.	Static electric protective sack	10 pcs
2.	Packing case ( inner box ) include shock absorber	1 set
3.	Pictorial marking	2 pics
4.	Carton	1 set

**10. Marking & Others**

A nameplate bearing followed by is affixed to a shipped product at the specified location on each product.

(1)Parts number : LTA120W1-T01

(2)Revision : One letter

(3)Control Code : One letter

(4)Lot number : X X X ~~XXX~~ ~~XXX~~

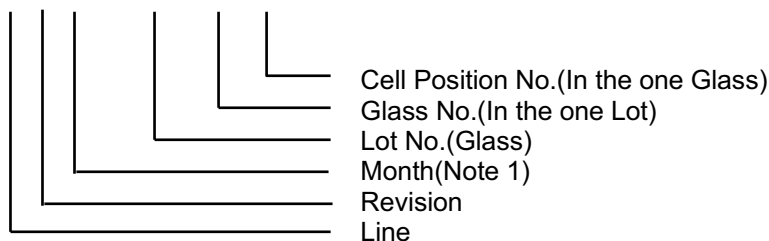

NOTE 1). This code indicating year is omitted in the products of KIHENG site.

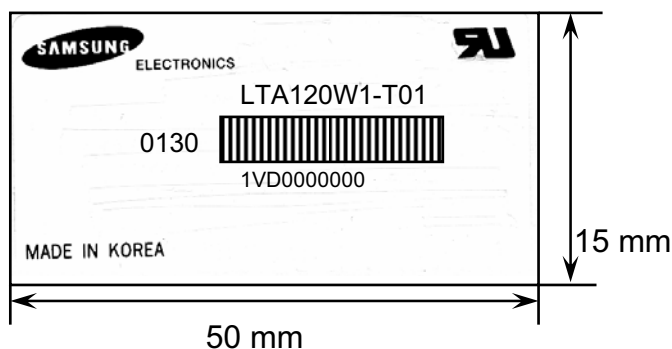
**(5) Nameplate Indication**

LTA... : Parts name  
1VD... : Lot number  
0130 : Inspected work week

Doc.No.	LTA120W1-T01	Rev.No	05 - 000 - G - 051201	Page	24/25
---------	--------------	--------	-----------------------	------	-------



## High voltage caution

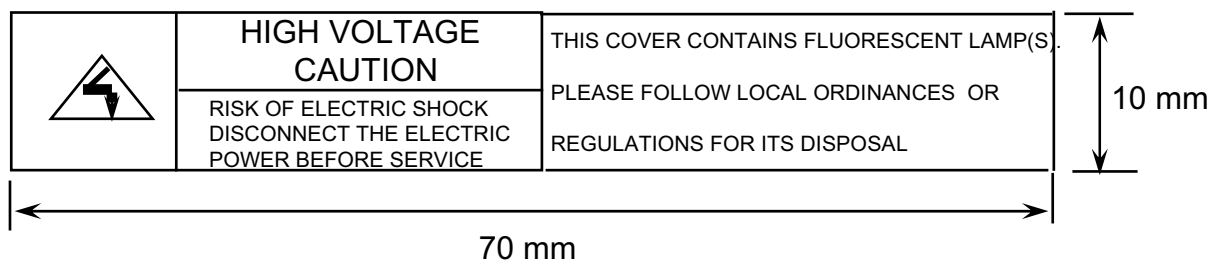

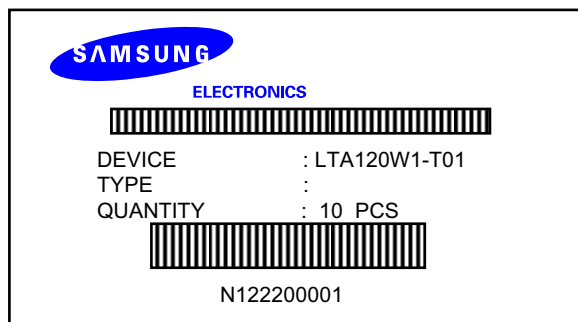

## (6) Packing box attach



Samsung Confidential

# Cosmetic Standards for Outgoing Inspection

## ( LTA120W1-T01 TFT- LCD )

Document Control			
Document NO : COS_12.0"_051128			
Customer (OP Car)		Supplier ( SAMSUNG Electronics )	
Approved by	Signature Here	Prepared by	
		Checked by	
		Approved by	

REVISION RECORD		
REV	REVISION ITEM	DATE
0	Engineering release	2005. 11. 28

All materials in this document are highly confidential and proprietary to Samsung electronics.

Any part of this document can not be copied or reproduced, in whole or in part, without the written permission of Samsung electronics.

Address : San 24 Nongseo-Ri, Giheung-Eup, Yongin-City, Gyeonggi-Do, Korea 449-711  
Tel. 82-31-209-6134 Fax. 82-31-209-7607

Cosmetic Standard for Outgoing Inspection Rev. 00



1

*Samsung Confidential*

## 1. Inspection Conditions:

- ✓ Viewing distance                      25 ± 5 cm
- ✓ Ambient illumination
  - . Operating Inspection            50 ~ 150 Lux
  - . Appearance Inspection        1000 ~ 1500 Lux
- ✓ Viewing angle                      Within 30 degrees left,  
right, 30 degrees up and  
down as the right  
picture shown
- ✓ Ambient temperature              22 ± 5 'C
- ✓ Display pattern                      12.0" WVGA - R, G, B, Black, White
- ✓ Inspection area                      Active area which is operating with pixels.

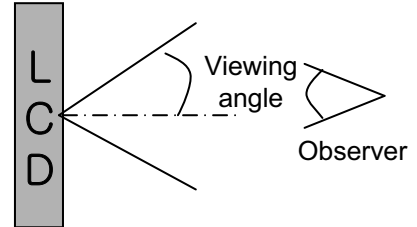

## 2. Inspection Criteria:

### 2-1. Visual Inspection

#### 2-1-1 Definition of Visual defects

- ✓ SPOT
  - Black/White spot appeared on the display which remain unchanged size.
- ✓ Line
  - Dark/Bright lines appeared on the display which remain unchanged in size.
- ✓ Polarizer Scratch
  - When the unit lights, visible scar or streak appear on the surface of polarizer.
- ✓ Polarizer Dent/Bubble
  - When the unit lights, visible carved mark or bubble on the surface of polarizer.

**Samsung Confidential****2-1-2 Visual Defect Criteria**

Below judgment criteria contains of glasses and polarizer defect.

Table1. Visual Defect Criteria

Defect Mode	Acceptable Judgment Criteria	
Spot particles (Black or White)	Size D (mm)	Quantity (ea)
	$D \leq 0.1$	Disregard
	$0.1 < D \leq 0.7$	3
Line particles (Black or White)	Width W(mm), Length L(mm)	Quantity (ea)
	$W \leq 0.01$	Disregard
	$0.01 < W \leq 0.1$ $0.3 < L \leq 1.0$	3
Polarizer Bubble/Dent	Size D (mm)	Quantity (ea)
	$D \leq 0.5$	4
Polarizer scratch	Width W(mm), Length L(mm)	Quantity (ea)
	$0.01 < W \leq 0.1$ $0.3 < L \leq 5.0$	3
	Maximum allowable number of defect	5

➤ **Remarks (How to measure?)**

- Use inspection tools like a loupe or microscope if unsure of pass/fail criteria.
- Translucent edge is ignored in measuring the diameter of spot.

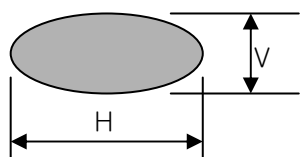

- Diameter of Spots and Bubbles  
 $D = [ \text{Vertical}(V) + \text{Horizontal}(H) ] / 2$

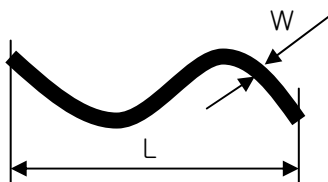

- Length and Width of Lines and Scratches



*Samsung Confidential***2-2. Pixel Inspection****2-2-1 Definition of Pixel defects**

## ✓ Pixel

3 sub-pixels ( R+G+B )



## ✓ DOT

1 sub-pixel ( R or G or B /  or  or  )

## ✓ Bright/Dark Dot

A sub-pixel (R,G,B dot) stuck off/on (electrical)

*Bright dots shall be counted on a black pattern and black dots on a pure R,G,B and white pattern.*

## ✓ Adjacent Dot

2 or 3 dots connected with neighboring dot. ( R,G or G,B or B,R or R,G,B )

**2-2-2 Dot Defect Criteria**Table2. Dot Defect Criteria

Defect Mode	Acceptable Judgment Criteria	
	<i>Dot Type</i>	<i>Quantity (ea)</i>
Bright Dot	Random ( Red , Blue, Green )	1
	2 adjacent dots	0
Dark Dot	Dark dot	2
	2 adjacent dots	1
Total Dot Defects	Maximum allowable number of dot defect	4

*Samsung Confidential*

## 2-3. The other Inspections

### 2-3-1 Functional Defects

**Below items are considered to be failure.**

✓ Line Defect

One or more permanent horizontal or vertical lines on a white/black display.

✓ No Display

No pixels are active when power and valid data are applied to the display.

✓ No Back Light

No or weak light from the LED/CCFL when the backlight is activated.

*( Measure brightness or uniformity if unsure of pass/fail criteria. )*

✓ Gray Defect

Abnormal display of gray colored level on a specified R,G,B pattern.

*( Measuring chromaticity if unsure of pass/fail criteria. )*

✓ Noise

Wave on display due to electrical ripple or noise.

✓ Abnormal Display

Abnormal display excluding items mentioned above.

***- If not issued from the customer site or not described above , SEC follows internal guide line.***