

Customer :

Date : 2003. 01. 29

SAMSUNG TFT-LCD

MODEL NO. : LTA220W1-L02

Note:

Any Modification of Spec is not allowed without SEC's permission.

Senior Engineer :

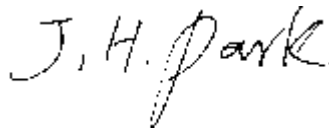

PREPARED BY : AMLCD TECHNICAL CUSTOMER SERVICE TEAM

Samsung Electronics Co . , LTD.



Contents

General Description	-----	(3)
1. Absolute Maximum Ratings	-----	(4)
1.1 Absolute Ratings Of Environment		
1.2 Electrical Absolute Ratings		
2. Optical Characteristics	-----	(6)
3. Electrical Characteristics	-----	(10)
3.1 TFT LCD Module		
3.2 Back-light Unit		
4. Block Diagram	-----	(13)
4.1 TFT LCD Module		
4.2 Back-light Unit		
5. Input Terminal Pin Assignment	-----	(14)
5.1 Input Signal & Power		
5.2 LVDS Interface		
5.3 Inverter Unit		
5.4 Input Signals, Basic Display Colors and Gray Scale of Each Color		
6. Interface Timing	-----	(18)
6.1 Timing Parameters (DE only mode)		
6.2 Timing Diagrams of interface Signal (DE only mode)		
6.3 Power ON/OFF Sequence		
7. Outline Dimension (described in another file)	-----	(22)
8. General Precautions	-----	(23)
9. Packing	-----	(25)
10. Marking & Others	-----	(27)

General Description

* Description

LTA220W1-L02 is a color active matrix TFT (Thin Film Transistor) liquid crystal display (LCD) that uses amorphous silicon TFTs as a switching devices. This model is composed of a TFT LCD panel, a driver circuit and a back-light system. The resolution of a 22.0" contains 1280 x 720 pixels and can display up to 16.7 million colors with wide viewing angle of 85° or higher in all directions.

* Features

- High contrast ratio, high aperture structure
- PVA (Patterned Vertical Alignment) mode
- Wide viewing angle ($\pm 170^\circ$)
- High speed response
- WXGA(1280 x 720 pixels) resolution (16:9)
- Low Power consumption
- Direct Type 8 CCFT(Cold Cathode Fluorescent Tube)
- DE only mode
- LVDS(Low-Voltage Differential Signaling) interface.(1pixel/clock)

* Applications

Home-alone Multimedia TFT-LCD TV
 Display terminals for AV application products
 High Definition TV (HD TV)

* General information

Items	Specification	Unit	Note
Display area	487.68(H) x 274.32(V)	mm	
Driver element	a-Si TFT active matrix		
Display colors	16.7M(true)	colors	
Number of pixels	1280 x 720	pixel	16:9
Pixel arrangement	RGB Vertical Stripe		
Pixel pitch	0.381(H) x 0.381(W)	mm	
Display mode	Normally Black		
Surface treatment	Haze 44% , Hard-Coating (3H)		

*** Mechanical information (Panel Module Only)**

Item		Min.	Typ.	Max.	Note
Module size	Horizontal(H)	525.1	525.6	526.1	mm
	Vertical(V)	307.4	307.9	308.4	mm
	Depth(D)	-	-	38.8	mm
Weight		-	-	2,700	g

1. Absolute Maximum Ratings

1.1 Absolute ratings of environment

Item	Symbol	Min.	Max.	Unit	Note
Storage temperature	T _{STG}	-20	60	°C	(1)
Operating temperature (Ambient temperature)	T _{OPR}	0	50	°C	(1)
Shock (non - operating)	Snop	-	50	G	(2),(4)
Vibration (Non - operating)	Vnop	-	1.5	G	(3),(4)

Note (1) Temperature and relative humidity range are shown in the figure below.

90 % RH Max. (40 °C ≥ Ta)

Maximum wet-bulb temperature at 39 °C or less. (Ta > 40 °C) No condensation.

- (2) 11ms, sine wave, 1 time for ±X, ±Y, ±Z axis
- (3) 10-300 Hz, Sweep rate 10min, 30min for X,Y,Z axis
- (4) At testing Vibration and Shock, the fixture in holding the Module to be tested have to be hard and rigid enough so that the Module would not be twisted or bent by the fixture.

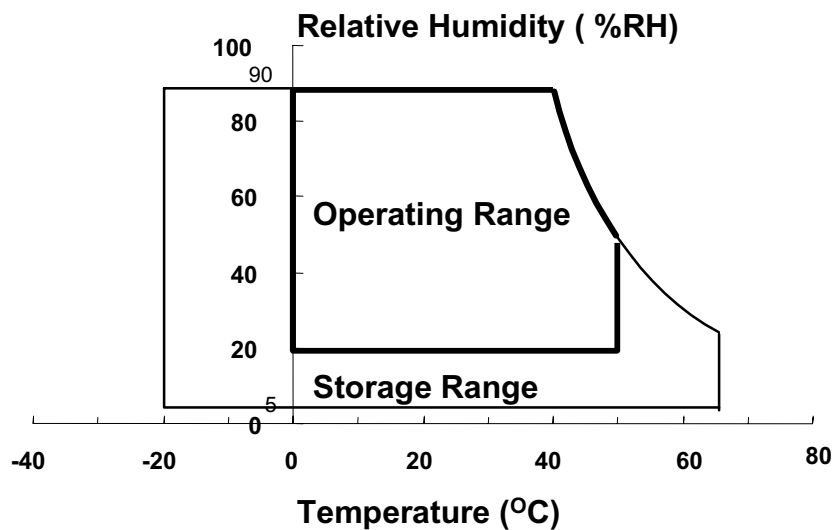

1.2 ELECTRICAL ABSOLUTE RATINGS

(1) TFT LCD Module

(V_{SS} = GND = 0 V)

Item	Symbol	Min.	Max.	Unit	Note
Power Supply Voltage	VDD	V _{SS} -0.5	6.5	V	(1)

NOTE (1) With Ta (25 ± 2 °C)

(2) BACK-LIGHT UNIT

(Ta = 25 ± 2°C)

Item	Symbol	Min.	Max.	Unit.	Note
Lamp Current	I _L	4.0	7.0	mArms	(1),(2)
Lamp Frequency	F _L	40	80	kHz	(1)

NOTE (1) Permanent damage to the device may occur if maximum values are exceeded.
Functional operation should be restricted to the conditions described under
Normal Operating Conditions.

(2) Specified values are for a single lamp.

2. Optical Characteristics

The following items are measured under stable conditions. The optical characteristics should be measured in a dark room or equivalent state with the methods shown in Note (1).

◆ Measuring equipment : TOPCON BM-5A , BM-7, PHOTO RESEARCH PR650
Eldim EZ-Contrast

* Ta = 25 ± 2°C , VDD=5V, fv= 60Hz, fDCLK=65 MHz, IL = 6.0mArms

Item	Symbol	Condition	Min.	Typ.	Max.	Unit	Note	
Contrast Ratio (Center of screen)	C/R		400	500	-		(3) BM-5A	
Response Time	Rising	Tr	-	15	16.6	msec	(4) BM-7	
	Falling	Tf	-	8	11			
Luminance of White (Center of screen)	YL	Normal $\phi = 0$	400	450	-	cd/m2	(5) BM-5A	
Color Chromaticity (CIE 1931)	Red	Rx	Viewing Angle	(0.643)	Typ. -0.030	Typ. +0.030	(6) PR650	
		Ry		(0.334)				
	Green	Gx		(0.282)				
		Gy		(0.576)				
	Blue	Bx		(0.145)				
		By		(0.065)				
	White	Wx		(0.272)				
		Wy		(0.277)				
Color temperature	K		-	12,000	-			
Viewing Angle	Hor.	θ L	C/R \geq 10	75	85	-	Degrees	(7) BM-5A
		θ R		75	85	-		
	Ver.	ϕ H		75	85	-		
		ϕ L		75	85	-		
Brightness Uniformity (9 points)	Buni		-	-	25	%	(2),(8) BM-5A	

Note 1) Test Equipment Setup

After stabilizing and leaving the panel alone at a given temperature for 30 min ,the measurement should be executed. Measurement should be executed in a stable, windless, and dark room. 30 min after lighting the back-light. This should be measured in the center of screen.

A single lamp current : 6.0mA

Environment condition : $T_a = 25 \pm 2 \text{ }^\circ\text{C}$

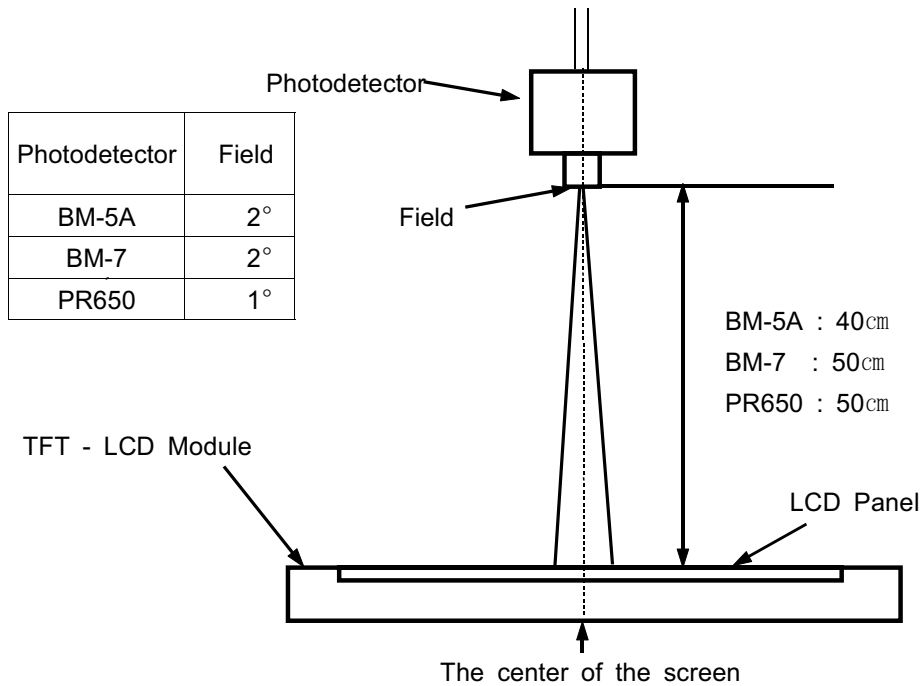

Photodetector	Field
BM-5A	2°
BM-7	2°
PR650	1°

Optical Measuring Equipment Setup

Note 2) Definition of test point

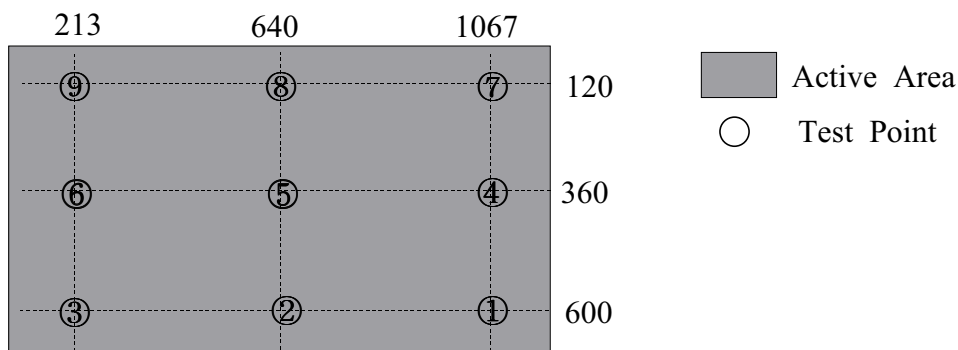

Note 3) Definition of Contrast Ratio (C/R) : Ratio of gray max (Gmax) & gray min (Gmin) at the center point(5) of the panel

$$CR = \frac{G \max}{G \min}$$

Gmax : Luminance with all pixels white

Gmin : Luminance with all pixels black

Note 4) Definition of Response time : Sum of T_r , T_f

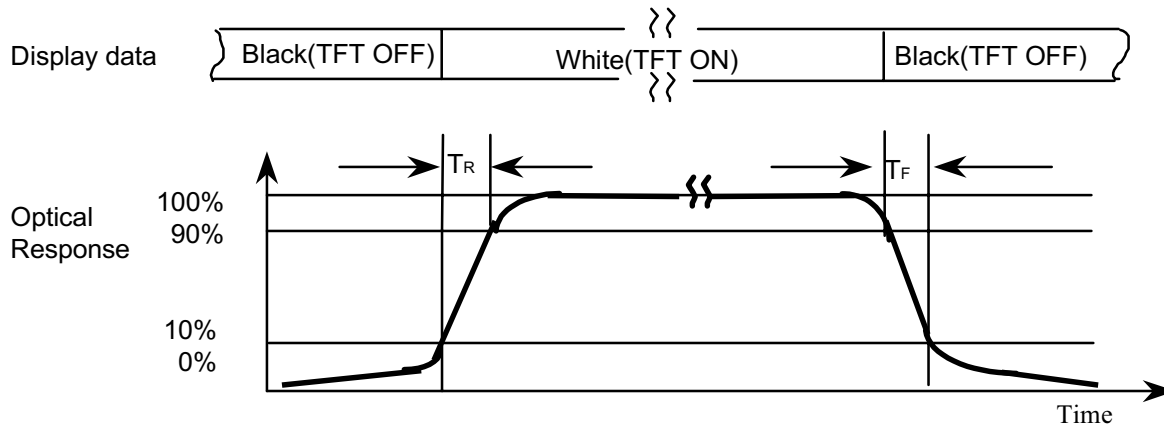

Note 5) Definition of Luminance of White : Luminance of white at center point(5).

Note 6) Definition of Color Chromaticity (CIE 1931)

Color coordinate of Red , Green , Blue & White at center point(5).

Note 7) Definition of Viewing Angle : Viewing angle range ($CR \geq 10$)

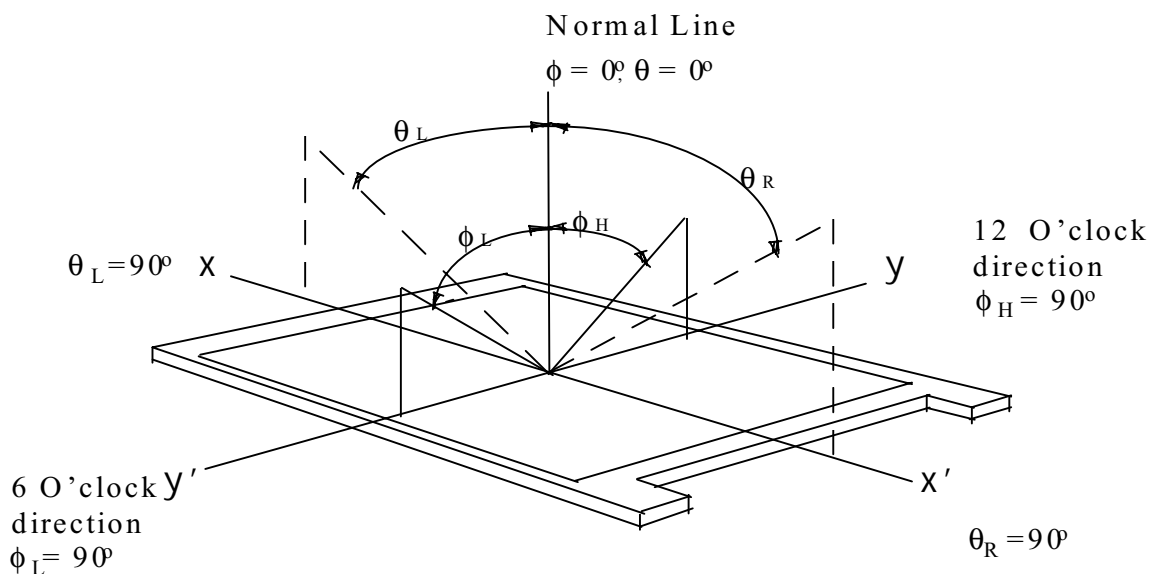

Note 8) Definition of 9 points brightness uniformity

$$B_{uni} = 100 * \frac{(B_{max} - B_{min})}{B_{max}}$$

Bmax : Maximum brightness

Bmin : Minimum brightness

3. Electrical Characteristics

3.1 TFT LCD MODULE

Ta = 25°C

Item	Symbol	Min.	Typ.	Max.	Unit	Note	
Voltage of Power Supply	V _{DD}	4.5	5.0	5.5	V	(1)	
Interface LVDS input level	LVDS	250	350	450	mVp_p	DS90C386	
Current of Power Supply	(a)Black	I _{DD}	700	-	900	mA	(2),(3)
	(b)Mosaic		720	-	910	mA	
	(c)2 Line Stripe		800	-	990	mA	
	(d)White		710	-	960	mA	
Vsync Frequency	f _V	48	60	66	Hz	1 pixel/clock	
Hsync Frequency	f _H	47.5	48.5	49.5	kHz		
Main Frequency	f _{DCLK}	58	65	70	MHz		
Rush Current	I _{RUSH}	-	-	3.0	A	(4)	

- Note (1) Voltage of Power Supply is the value which is measured at the input connector of panel.
 (2) f_V=60Hz, f_{DCLK} =65MHz, V_{DD} = 5.0V, DC Current.
 (3) Power dissipation check pattern(LCD Module only)

a)Black Pattern

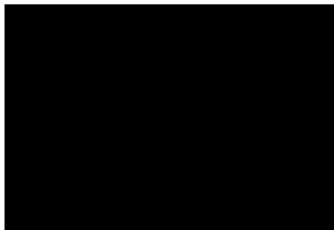

b)Mosaic Pattern

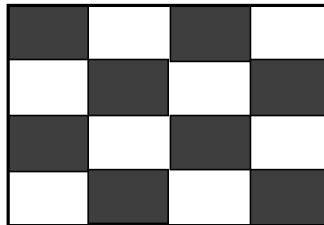

c)2 Line Stripe

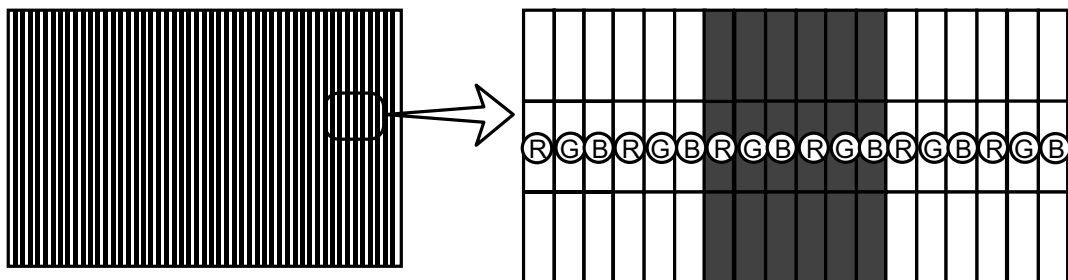

d)White Pattern



(4) Measurement Conditions

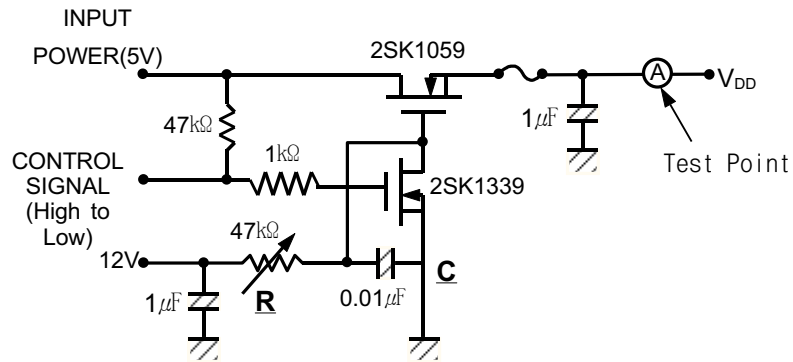

Note : Control Signal : High(+5V) -->Low(Ground)

All Signal lines to panel except for power 5V : Ground

The rising time of supplied voltage is controlled to 470us by R and C value.

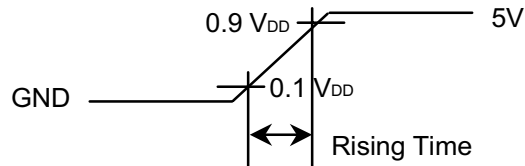

3.2 BACK-LIGHT UNIT

The back-light system is an direct - lighting type with 8 CCFTs (Cold Cathode Fluorescent Tube) The characteristics of 8 direct lamps are shown in the following tables.

Ta=25 ± 2°C

Item	Symbol	Min.	Typ.	Max.	Unit	Note
Lamp Current	I _L	4.0	6.0	7.0	mArms	(1)
Lamp Voltage	V _L	905	935	1005	Vrms	(1)
Lamp Frequency	f _L	47.5	48.5	49.5	kHz	(2)
Operating Life Time	Hr	50,000	-	-	Hour	(3) at 7.0mA
		60,000	-	-		at 5.5mA
Start up Voltage	Vs	-	-	0°C: 1840	Vrms	(4)
				25°C:1530		

Note) The waveform of the inverter output voltage must be area symmetric and the design of the inverter must have specifications for the modularized lamp.

Specified values are for a single lamp.

The performance of the back-light, for example life time or brightness, is much influenced by the characteristics of the DC-AC inverter for the lamp. So all the parameters of an inverter should be carefully designed so as not to produce too much leakage current from high-voltage output of the inverter.

When you design or order the inverter, please make sure that a poor lighting caused by the mismatch of the back-light and the inverter(miss lighting, flicker, etc.) never occur. When you confirm it, the module should be operated in the same condition as it is installed in your instrument.

Note(1) lamp current is measured with current meter.

Refer to the block diagram of the back-light unit in the next page for more information.

Lamp Voltage tolerance (at 48.5KHz) : 1000±7%Vrms at 4mArms

900±7%Vrms at 7mArms

(2) Lamp frequency may produce interference with horizontal synchronous frequency and this may cause line flow on the display. Therefore lamp frequency shall be detached from the horizontal synchronous frequency and its harmonics as far as possible in order to avoid interference.

(3) Life time (Hr) of a lamp is defined as the time in which it continues to operate under the condition of Ta = 25±2°C and I_L = 7.0mArms for a lamp until the brightness becomes 50% or lower than it's original value.

(4) If an inverter has shutdown function it should keep its output for more than 1 second even if the lamp connector open. Otherwise the lamps may not to be turned on.

4. Block Diagram

4.1 TFT LCD MODULE

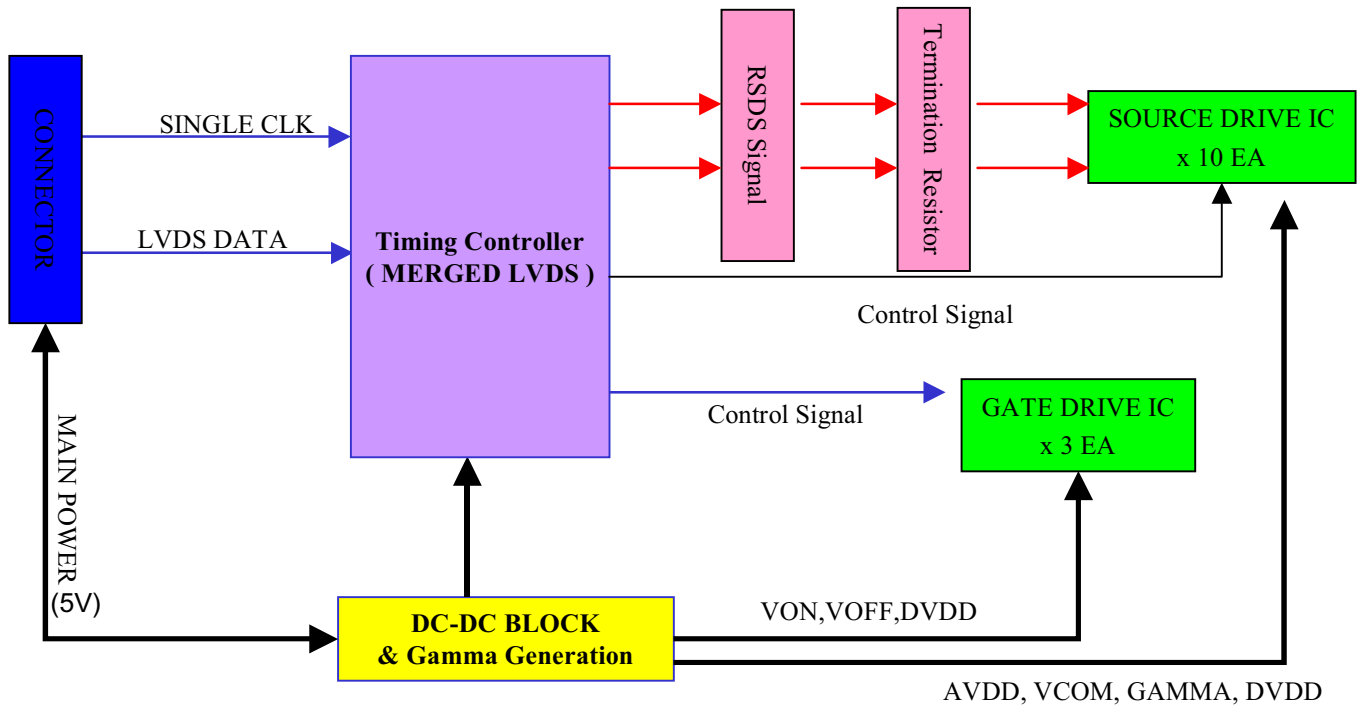

4.2 BACL-LIGHT UNIT

HOT : HIGH VOLTAGE (Part NO. : BHR-04VS-1 (JST))

COLD : GROUND (Part NO. : BHSR-02VS-1 (JST))

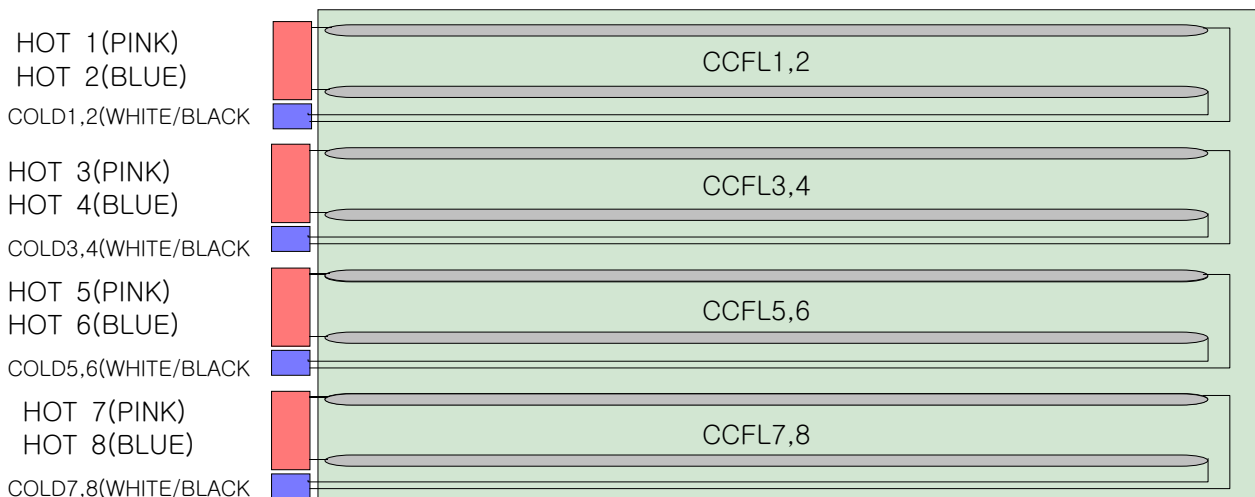

5. Input Terminal Pin Assignment

5.1. Input Signal & Power (Connector : DF14A-20P-1.25H, HIROSE)

PIN NO	SYMBOL	FUNCTION
1	NC	No Connection
2	Gnd	Ground
3	Rx0-	Negative Transmission Data of Pixel 0
4	Rx0+	Positive Transmission Data of Pixel 0
5	Gnd	Ground
6	Rx1-	Negative Transmission Data of Pixel 1
7	Rx1+	Positive Transmission Data of Pixel 1
8	Gnd	Ground
9	Rx2-	Negative Transmission Data of Pixel 2
10	Rx2+	Positive Transmission Data of Pixel 2
11	Gnd	Ground
12	Rclk-	Negative Sampling Clock
13	Rclk+	Positive Sampling Clock
14	Gnd	Ground
15	Rx3-	Negative Transmission Data of Pixel 3
16	Rx3+	Positive Transmission Data of Pixel 3
17	Gnd	Ground
18	Gnd	Ground
19	VDD	Power Supply : 5V
20	VDD	Power Supply : 5V

5.2 LVDS Interface

-LVDS Receiver : Tcon (LVDS Rx merged)

-Pixel data (Single Data)

LVDS Transmitter (<i>DS90C385</i>) Signal Interface						
Device Input Pin		Device Input Signal		Output Signal	To LTA220W1 Interface (CN101)	
No	Symbol	Symbol	Function		Terminal	Symbol
51	TXIN0	RO0	Red Odd Pixel Data (LSB)	TXOUT0- TXOUT0+	No. 3 No. 4	RX0- RX0+
52	TXIN1	RO1	Red Odd Pixel Data			
54	TXIN2	RO2	Red Odd Pixel Data			
55	TXIN3	RO3	Red Odd Pixel Data			
56	TXIN4	RO4	Red Odd Pixel Data			
2	TXIN5	RO7	Red Odd Pixel Data (MSB)	TXOUT3- TXOUT3+	No. 15 No. 16	RX3- RX3+
3	TXIN6	RO5	Red Odd Pixel Data	TXOUT0- TXOUT0+	No. 3 No. 4	RX0- RX0+
4	TXIN7	GO0	Green Odd Pixel Data (LSB)			
6	TXIN8	GO1	Green Odd Pixel Data	TXOUT1- TXOUT1+	No. 6 No. 7	RX1- RX1+
7	TXIN9	GO2	Green Odd Pixel Data	TXOUT3- TXOUT3+	No. 15 No. 16	RX3- RX3+
8	TXIN10	GO6	Green Odd Pixel Data			
10	TXIN11	GO7	Green Odd Pixel Data (MSB)			
11	TXIN12	GO3	Green Odd Pixel Data	TXOUT1- TXOUT1+	No. 6 No. 7	RX1- RX1+
12	TXIN13	GO4	Green Odd Pixel Data			
14	TXIN14	GO5	Green Odd Pixel Data			
15	TXIN15	BO0	Blue Odd Pixel Data (LSB)			
16	TXIN16	BO6	Blue Odd Pixel Data	TXOUT3- TXOUT3+	No. 15 No. 16	RX3- RX3+
18	TXIN17	BO7	Blue Odd Pixel Data (MSB)			
19	TXIN18	BO1	Blue Odd Pixel Data	TXOUT1- TXOUT1+	No. 6 No. 7	RX1- RX1+
20	TXIN19	BO2	Blue Odd Pixel Data	TXOUT2- TXOUT2+	No. 9 No.10	RX2- RX2+
22	TXIN20	BO3	Blue Odd Pixel Data			
23	TXIN21	BO4	Blue Odd Pixel Data			
24	TXIN22	BO5	Blue Odd Pixel Data			
50	TXIN27	RO6	Red Odd Pixel Data	TXOUT3- TXOUT3+	No. 15 No. 16	RX3- RX3+

5.3 INVERTER UNIT

1) INPUT CONNECTOR 1 : 12505WR-15A00 (Yeonho Elec.) / 53261-1590 (Molex)

Pin No.	1	2	3	4	5	6	7
Function	Vin	Vin	Vin	Vin	Vin	Vin	Vin
8	9	10	11	12	13	14	15
On/Off	Ground	Ground	Ground	Ground	Ground	Ground	Ground

2) INPUT CONNECTOR 2 : 12505WR-04A00 (Yeonho Elec.) / 53261-0490 (Molex)

Pin No.	1	2 (Note 1)	3 (Note 2)	4 (Note 3)
Function	Ground	Brt_Adj. for AI 0~5[V]	Brt_Adj. for PWM Duty :30~100%	Hsync(48.5[kHz])

Note 1. Brt_Adj for A.I. is active at low status.

Note 2. Brt_Adj for PWM is active at low status.

Note 3. The polarity of Hsync don't care in negative/positive. (range : 10 ~ 90%)

3) OUTPUT HOT Connector : 20015WR-07A01 (Yeonho Elec.)/SM02(12)B-BHS-1-TB (JST)

4) OUTPUT COLD Connector : 35001 (Yeonho Elec.) / SM02B-BHSS-1-TB (JST)

5.4 INVERTER Input Specification

Item	Symbol	Min.	Typ.	Max.	Unit	Note
Inverter Main power	Vaa	14	15	16	V	(1)
	Iaa	2.9	3.1	3.3	A	
PWM dimming	High-duty	30	-	100	%	(2)
	High (Off)	3.0	-	5.25	V	
	Low (On)	0	-	0.8		
Analog dimming	Van	5	1.3	0	V	(3)
	IL	4±0.5	6±0.5	7±0.5	mArms	
Lamp current	Maximum	6.5	7.0	7.5	mArms	(4)
	Minimum	3.5	4.0	4.5		
Back-light On/Off	High (On)	3.0	-	5.25	V	
	Low (Off)	0	-	0.8		

Note(1) Controlled by Analog or PWM dimming

Note(2) High-duty = On/(On+Off) * 100

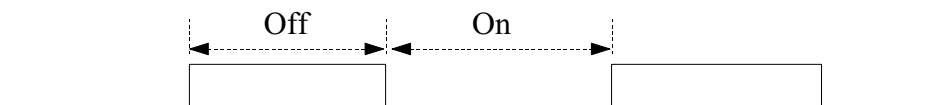

Note(3) PWM ON Duty = 100%

Note(4) - Controlled by Analog dimming only (Lamp current is 6mA,(typ). and PWM is 100%)

- Analog dimming 5V (Minimum Lamp current)

- Analog dimming 0V (Maximum Lamp current)

5.5 Input Signal, Basic Display Colors and Gray Scale of Each Color

COLOR	DISPLAY	DATA SIGNAL																					GRAY SCALE LEVEL			
		RED							GREEN							BLUE										
		R0	R1	R2	R3	R4	R5	R6	R7	G0	G1	G2	G3	G4	G5	G6	G7	B0	B1	B2	B3	B4		B5	B6	B7
BASIC COLOR	BLACK	0	0	0	0	0	0	0	0	0	0	0	0	0	0	0	0	0	0	0	0	0	0	0	0	-
	BLUE	0	0	0	0	0	0	0	0	0	0	0	0	0	0	0	0	1	1	1	1	1	1	1	1	-
	GREEN	0	0	0	0	0	0	0	0	1	1	1	1	1	1	1	1	0	0	0	0	0	0	0	0	-
	CYAN	0	0	0	0	0	0	0	0	1	1	1	1	1	1	1	1	1	1	1	1	1	1	1	1	-
	RED	1	1	1	1	1	1	1	1	0	0	0	0	0	0	0	0	0	0	0	0	0	0	0	0	-
	MAGENTA	1	1	1	1	1	1	1	1	0	0	0	0	0	0	0	0	1	1	1	1	1	1	1	1	-
	YELLOW	1	1	1	1	1	1	1	1	1	1	1	1	1	1	1	1	0	0	0	0	0	0	0	0	-
	WHITE	1	1	1	1	1	1	1	1	1	1	1	1	1	1	1	1	1	1	1	1	1	1	1	1	-
GRAY SCALE OF RED	BLACK	0	0	0	0	0	0	0	0	0	0	0	0	0	0	0	0	0	0	0	0	0	0	0	R0	
	DARK ↑	0	0	0	0	0	0	0	0	0	0	0	0	0	0	0	0	0	0	0	0	0	0	0	0	R1
		0	1	0	0	0	0	0	0	0	0	0	0	0	0	0	0	0	0	0	0	0	0	0	0	R2
		:	:	:	:	:	:	:	:	:	:	:	:	:	:	:	:	:	:	:	:	:	:	:	:	R3~R252
		:	:	:	:	:	:	:	:	:	:	:	:	:	:	:	:	:	:	:	:	:	:	:	:	
	LIGHT ↓	1	0	1	1	1	1	1	1	0	0	0	0	0	0	0	0	0	0	0	0	0	0	0	0	R253
		0	1	1	1	1	1	1	1	0	0	0	0	0	0	0	0	0	0	0	0	0	0	0	0	R254
	RED	1	1	1	1	1	1	1	1	0	0	0	0	0	0	0	0	0	0	0	0	0	0	0	0	R255
GRAY SCALE OF GREEN	BLACK	0	0	0	0	0	0	0	0	0	0	0	0	0	0	0	0	0	0	0	0	0	0	0	G0	
	DARK ↑	0	0	0	0	0	0	0	0	1	0	0	0	0	0	0	0	0	0	0	0	0	0	0	0	G1
		0	0	0	0	0	0	0	0	0	1	0	0	0	0	0	0	0	0	0	0	0	0	0	0	G2
		:	:	:	:	:	:	:	:	:	:	:	:	:	:	:	:	:	:	:	:	:	:	:	:	G3~G252
		:	:	:	:	:	:	:	:	:	:	:	:	:	:	:	:	:	:	:	:	:	:	:	:	
	LIGHT ↓	0	0	0	0	0	0	0	0	1	0	1	1	1	1	1	1	0	0	0	0	0	0	0	0	G253
		0	0	0	0	0	0	0	0	0	1	1	1	1	1	1	1	0	0	0	0	0	0	0	0	G254
	GREEN	0	0	0	0	0	0	0	0	1	1	1	1	1	1	1	1	0	0	0	0	0	0	0	0	G255
GRAY SCALE OF BLUE	BLACK	0	0	0	0	0	0	0	0	0	0	0	0	0	0	0	0	0	0	0	0	0	0	0	B0	
	DARK ↑	0	0	0	0	0	0	0	0	0	0	0	0	0	0	0	0	1	0	0	0	0	0	0	0	B1
		0	0	0	0	0	0	0	0	0	0	0	0	0	0	0	0	0	1	0	0	0	0	0	0	B2
		:	:	:	:	:	:	:	:	:	:	:	:	:	:	:	:	:	:	:	:	:	:	:	:	B3~B252
		:	:	:	:	:	:	:	:	:	:	:	:	:	:	:	:	:	:	:	:	:	:	:	:	
	LIGHT ↓	0	0	0	0	0	0	0	0	0	0	0	0	0	0	0	0	1	0	1	1	1	1	1	1	B253
		0	0	0	0	0	0	0	0	0	0	0	0	0	0	0	0	0	1	1	1	1	1	1	1	B254
	BLUE	0	0	0	0	0	0	0	0	0	0	0	0	0	0	0	0	1	1	1	1	1	1	1	1	B255

Note) Definition of Gray :

Rn : Red Gray, Gn : Green Gray, Bn : Blue Gray (n = Gray level)

Input Signal : 0 = Low level voltage, 1 = High level voltage

6. Interface Timing

6.1 Timing Parameters (DE only mode)

SIGNAL	ITEM	SYMBOL	MIN.	TYP.	MAX.	UNIT	NOTE
Clock	Frequency	1/TC	58	65	70	MHz	
	Hgh Time	TCH	4	-	-	nsec	
	Low Time	TCL	4	-	-	nsec	
Data	Setup Time	TDS	4	-	-	nsec	
	Hold Time	TDH	4	-	-	nsec	
Data Enable	Setup Time	TES	4	-	-	nsec	
Frame Frequency	Cycle	Tv	15.1	16.7	20.8	msec	
			739	806	1122	lines	
Vertical Active Display Term	Display Period	TVD	720	720	720	lines	
	Verticle Blank Period	TVB	19	86	402	lines	
One Line Scanning Time	Cycle	TH	1332	1344	1436	clocks	
Horizontal Active Display Term	Display Period	THD	1280	1280	1280	clocks	

6.2 Timing diagrams of interface signal (DE only mode)

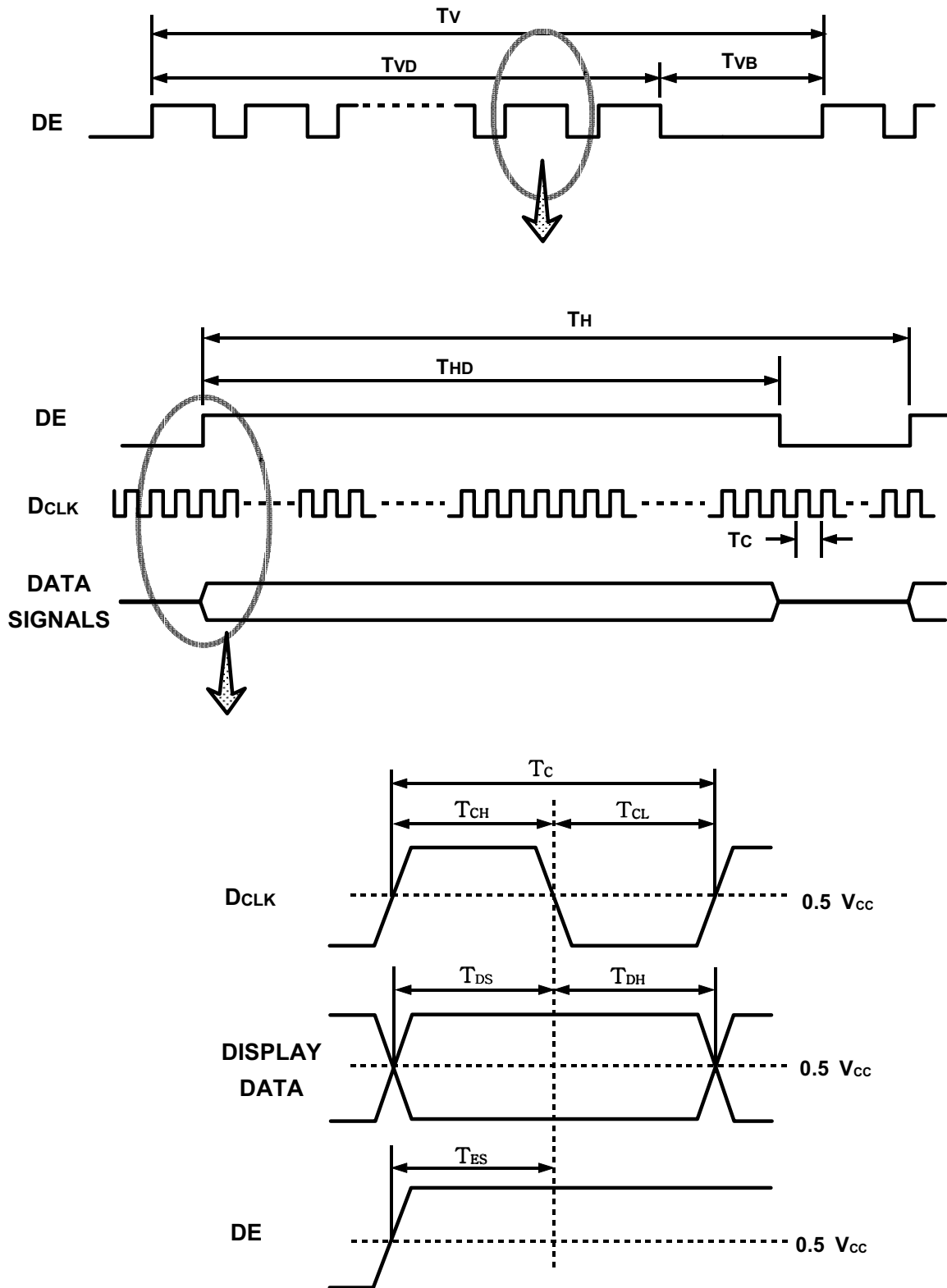

6.3 Power ON/OFF Sequence

: To prevent a latch-up or DC operation of the LCD module, the power on/off sequence should be as the diagram below.

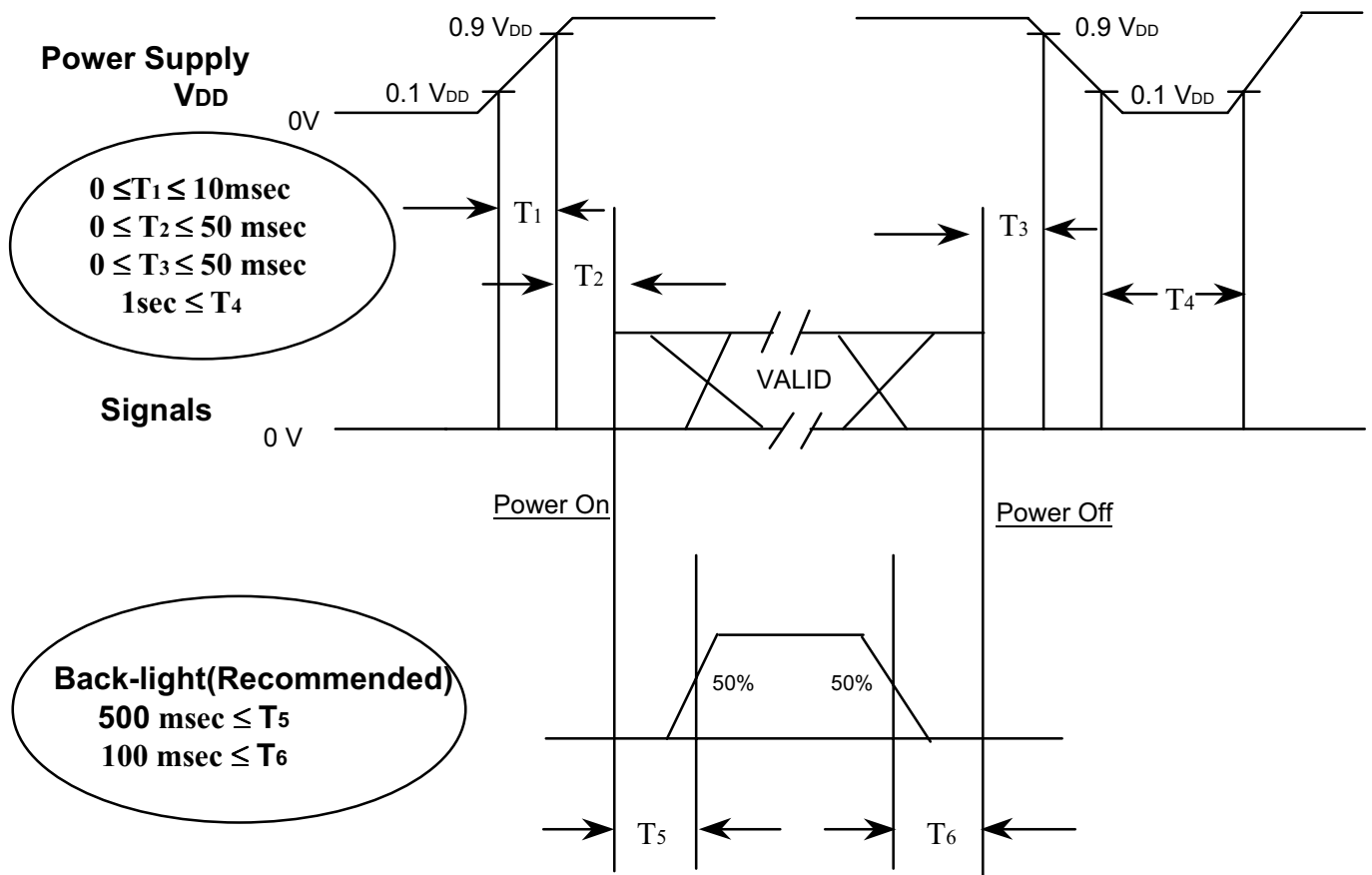

NOTE.

- (1) The supply voltage of the external system for the module input should be the same as the definition of V_{DD}.
- (2) Apply the lamp voltage within the LCD operation range. When the back-light turns on before the LCD operation or the LCD turns off before the back-light turns off, the display may momentarily become abnormal screen.
- (3) In case of V_{DD} = off level, please keep the level of input signals on the low or keep a high impedance.
- (4) T₄ should be measured after the module has been fully discharged between power off and on period.
- (5) Interface signal shall not be kept at high impedance when the power is on.

6.4 Inverter power sequence

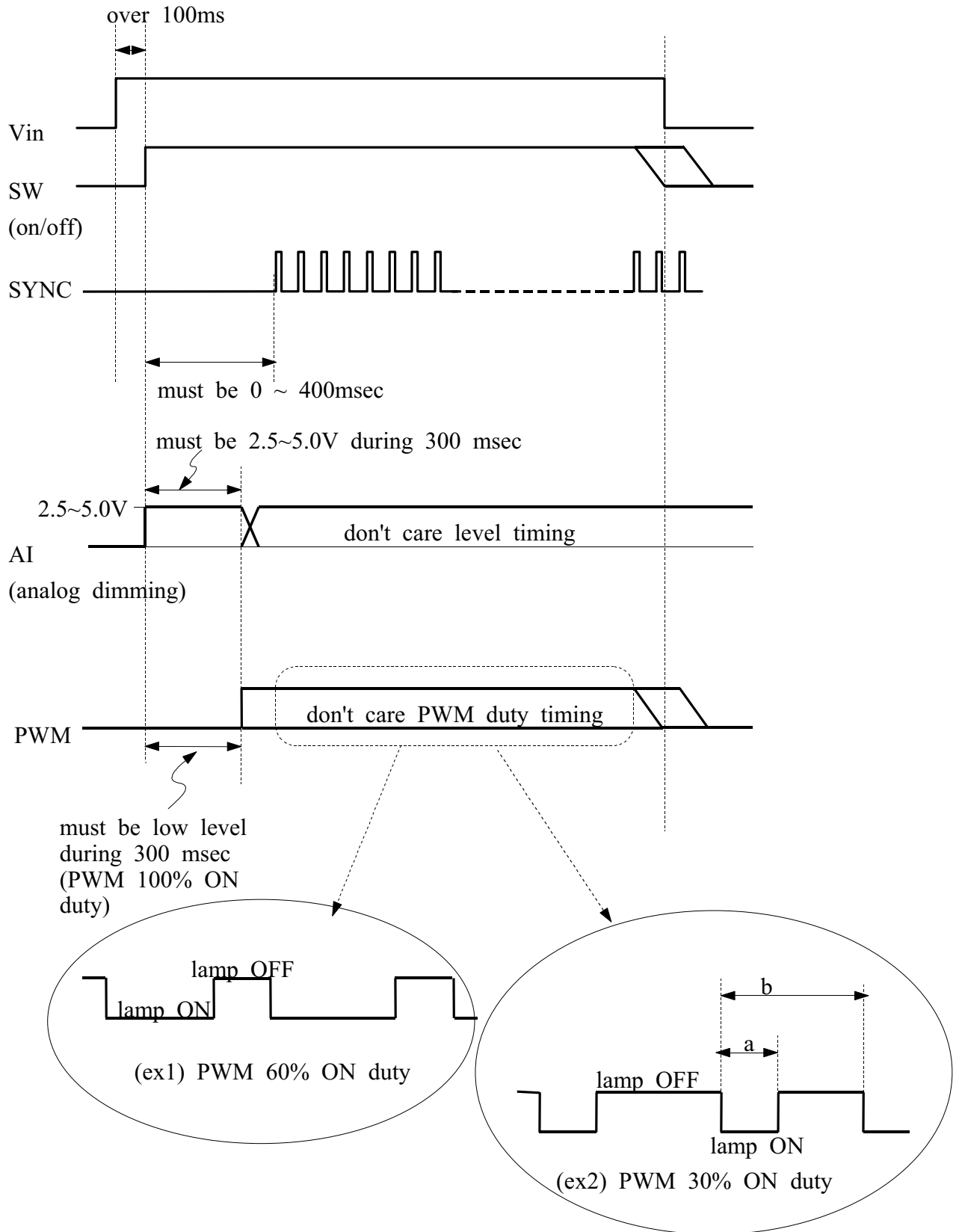

※PWM ON duty: the ratio that lamps are turned on.
 $= (a/b) \times 100$ [%]

7. Outline Dimension

.Refer to the another file

8. General Precautions

8.1 Handling

- (a) When the module is assembled, It should be attached to the system firmly using every mounting holes. Be careful not to twist and bend the modules.
- (b) Refrain from strong mechanical shock and / or any force to the module. In addition to damage, this may cause improper operation or damage to the module and CCFT back-light.
- (c) Note that polarizers are very fragile and could be easily damaged. Do not press or scratch the surface harder than a HB pencil lead.
- (d) Wipe off water droplets or oil immediately. If you leave the droplets for a long time, Staining and discoloration may occur.
- (e) If the surface of the polarizer is dirty, clean it using some absorbent cotton or soft cloth.
- (f) The desirable cleaners are water, IPA(Isopropyl Alcohol) or Hexane. Do not use Ketone type materials(ex. Acetone), Ethyl alcohol, Toluene, Ethyl acid or Methyl chloride. It might permanent damage to the polarizer due to chemical reaction.
- (g) If the liquid crystal material leaks from the panel, it should be kept away from the eyes or mouth . In case of contact with hands, legs or clothes, it must be washed away thoroughly with soap.
- (h) Protect the module from static , it may cause damage to the CMOS Gate Array IC.
- (i) Use finger-stalls with soft gloves in order to keep display clean during the incoming inspection and assembly process.
- (j) Do not disassemble the module.
- (k) Do not pull or fold the lamp wire.
- (l) Do not adjust the variable resistor which is located on the module.
- (m) Protection film for polarizer on the module shall be slowly peeled off just before use so that the electrostatic charge can be minimized.
- (n) Pins of I/F connector shall not be touched directly with bare hands.

8.2 Storage

- (a) Do not leave the module in high temperature, and high humidity for a long time. It is highly recommended to store the module with temperature from 0 to 35C and relative humidity of less than 70%.
- (b) Do not store the TFT-LCD module in direct sunlight.
- (c) The module shall be stored in a dark place. It is prohibited to apply sunlight or fluorescent light during the store.

8.3 Operation

- (a) Do not connect,disconnect the module in the "Power On" condition.
- (b) Power supply should always be turned on/off by the item 6.3 "Power on/off sequence"
- (c) Module has high frequency circuits. Sufficient suppression to the electromagnetic interference shall be done by system manufacturers. Grounding and shielding methods may be important to minimize the interference.
- (d) The cable between the back-light connector and its inverter power supply shall be a minimized length and be connected directly . The longer cable between the back-light and the inverter may cause lower luminance of lamp(CCFT) and may require higher startup voltage(Vs).

8.4 Others

- (a) Ultra-violet ray filter is necessary for outdoor operation.
- (b) Avoid condensation of water. It may result in improper operation or disconnection of electrode.
- (c) Do not exceed the absolute maximum rating value. (the supply voltage variation, input voltage variation, variation in part contents and environmental temperature, and so on. Otherwise the module may be damaged.
- (d) If the module displays the same pattern continuously for a long period of time,it can be the situation when the image "Sticks" to the screen.
- (e) This module has its circuitry PCB's on the rear side and should be handled carefully in order not to be stressed.

9. PACKING

9.1 CARTON(Internal Package)

(1) Packing Form

Corrugated fiberboard box and corrugated cardboard as shock absorber

(2) Packing Method

a) With Inverter

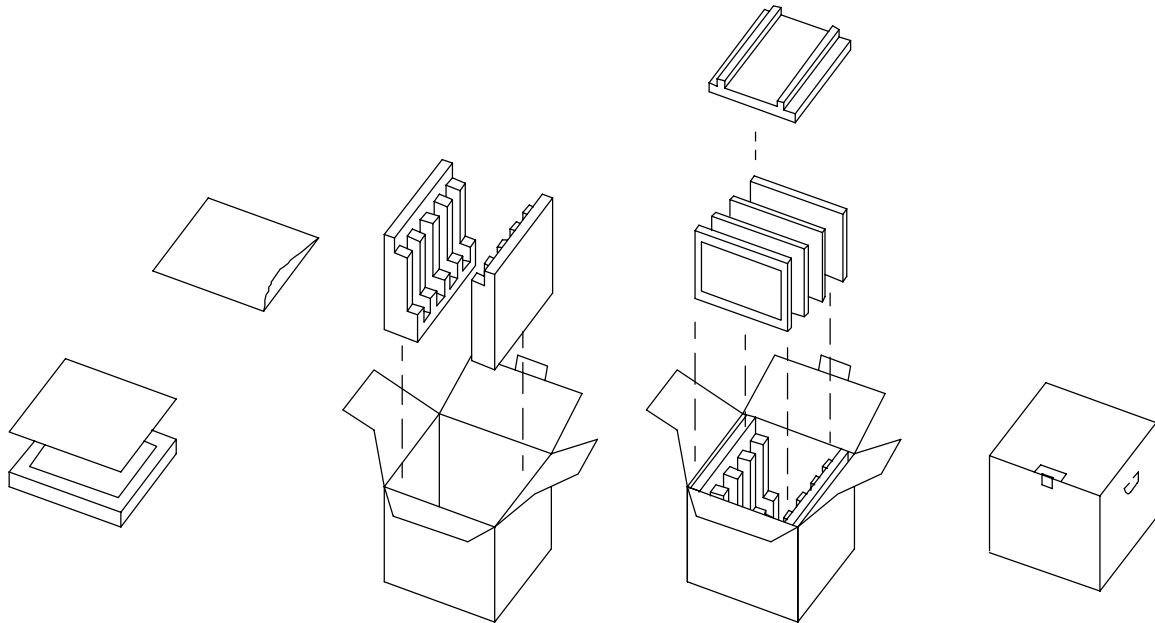

- NOTE) 1) TOTAL : Approx. 13.0kg
 2) Acceptance number of piling : 4sets
 3) Carton size : 684(W) * 352(D) * 482(H)
 4) MAX accumulation quantity : 4 cartons

(3) Packing Specification

ITEM	Specification	Remark
LCD Packing	4ea/Box	1. 2.7Kg/LCD 2. 2.2Kg/Box : Total 13Kg/ box 3. Packing case Material : SW4 4. Pallet cover Material : SW4 5. Pallet-box Material : DW4
Pallet	6Box/Pallet	1. Pallet weight: 6Kg 2. 78Kg/ Pallet 3. Total 88.5Kg/Pallet (Pallet cover 2 ea + Pallet-box 1 ea weight add)
Packing Direction	Vertical	3 row * 1 row * 2 steps

(4) Packing Material

No	Part name	Quality
1	Static electric protective sack	4
2	Packing case(Inner box) included shock absorber	1 set
3	Pictorial marking	2 pics
4	Carton	1 set

(5) Packing Cushion & Box

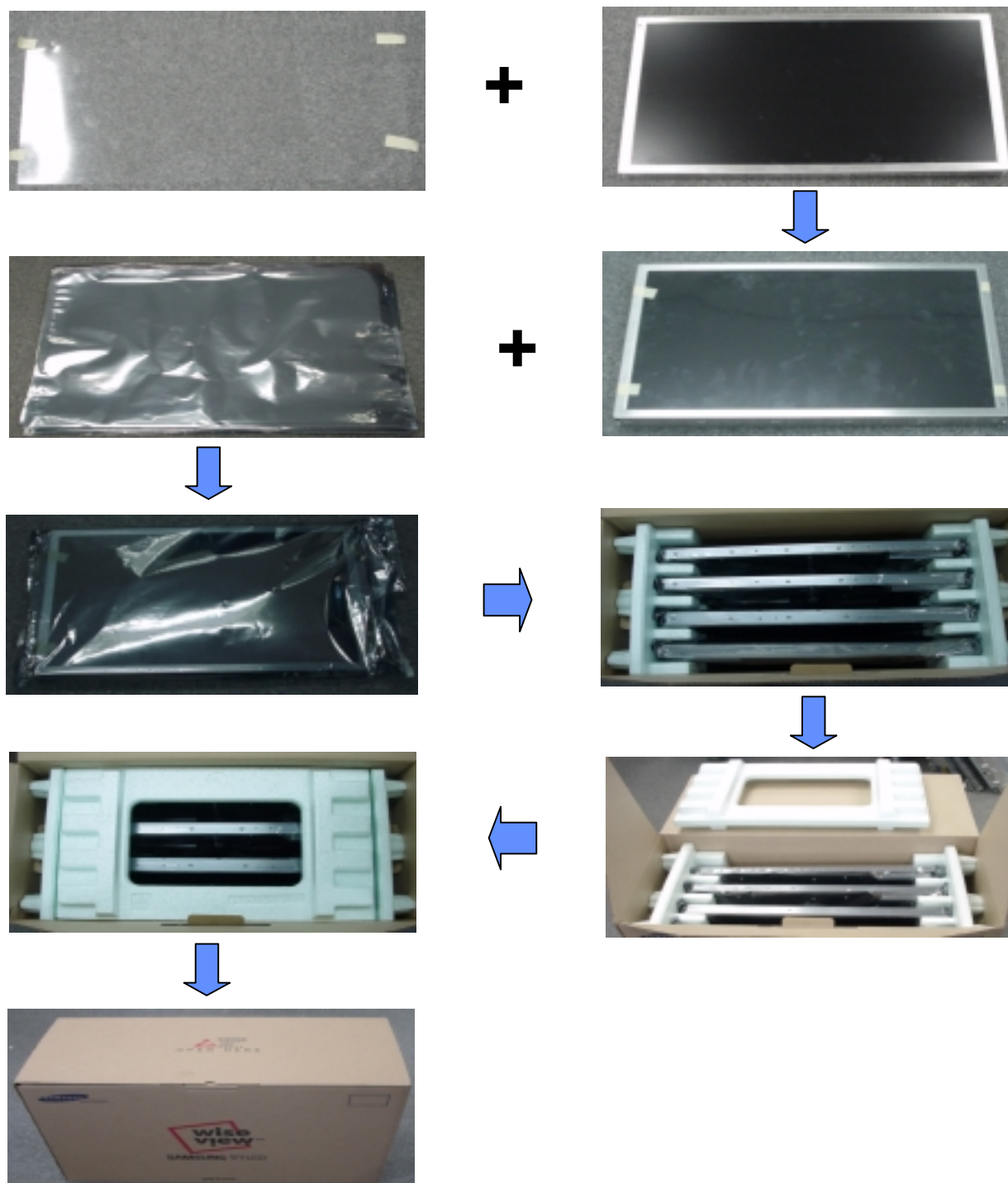

10. MARKING & OTHERS

A nameplate bearing followed by is affixed to a shipped product at the specified location on each product.

(1) Parts number : LTA220W1-L02

(2) Revision : One letter

(3) Control : One letter

(4) Lot number : 4 R0 000 00 -00

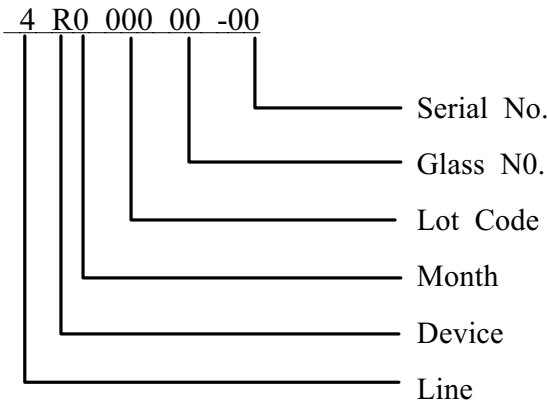

(5) Nameplate Indication

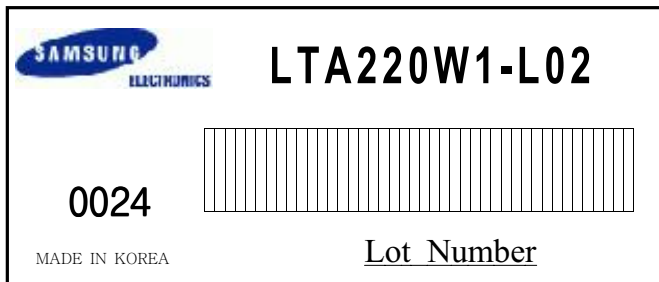

(6) Bar code marking for Customer

The bar code marking is attached to module backside.

- 1) MODEL NAME : LTA220W1-L02
- 2) SAMSUNG
- 3) MADE IN KOREA
- 4) PRODUCTION NUMBER
- 5) USER MODEL NAME

Bar code shows a) user model name, b) production number

a) User model name

LTA220W1-L02

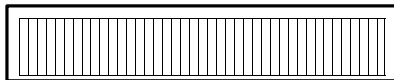

b) Production Number

SAMSUNG
MADE IN KOREA

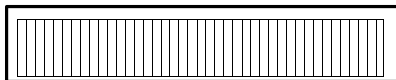

00000000

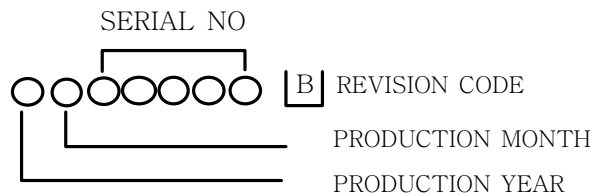

6) Packing box attach

