

**SAMSUNG DISPLAY**

Product Specification

- () **Preliminary Specification**
() **Approval Specification**

The information described in this SPEC is preliminary and can be changed without prior notice

CUSTOMER	PT Hartono
DATE OF ISSUE	2012.11.30

MODEL NO.	LTA230AN01
EXTENSION CODE	-8

LCD Sales & Marketing Team
Samsung Display Co., Ltd



SAMSUNG DISPLAY

Table of Contents

REVISION HISTORY	3
GENERAL DESCRIPTION	5
1.1 ENVIRONMENTAL ABSOLUTE RATINGS	5
2. OPTICAL CHARACTERISTICS.....	6
3. ELECTRICAL CHARACTERISTICS.....	9
3.1 TFT LCD MODULE	9
3.2 BACK LIGHT UNIT.....	10
3.3 CONVERTER CONNECTION CABLE.....	10
4. INPUT TERMINAL PIN ASSIGNMENT.....	11
4.1 INPUT SIGNAL & POWER.....	11
4.2 LVDS INTERFACE	12
4.3 INPUT SIGNALS, BASIC DISPLAY COLORS AND GRAY SCALE.....	12
5. INTERFACE TIMING	14
5.1 THE PARAMETERS OF TIMING(DE MODE)	14
5.2 TIMING DIAGRAMS OF INTERFACE SIGNAL(ONLY DE MODE)	15
5.3 CHARACTERISTICS OF INPUT DATA OF LVDS.....	16
5.4 THE SEQUENCE OF POWER ON AND OFF	17
6. OUTLINE DIMENSION.....	18
7. PACKING.....	19
8. MARKINGS & OTHERS	20
9. GENERAL PRECAUTIONS	21
9.1 HANDLING	21
9.2 STORAGE.....	22
9.3 OPERATION	22
9.4 OPERATION CONDITION GUIDE.....	23
9.5 OTHERS	23

SAMSUNG DISPLAY

GENERAL DESCRIPTION

DESCRIPTION

The LTA230AN01 is the one of liquid crystal display devices(LCD) that uses an amorphous silicon TFT(Thin Film Transistor) as switching components and a color active matrix. This model is composed of a TFT LCD panel, a driver circuit, and a back-light unit. This 23.0" model has a resolution of 1366 x 768 pixels and can display up to 16.7Million colors with the wide viewing angle of 89° or higher in all directions.

FEATURES

RoHS compliance(Pb-Free)
 High contrast ratio & aperture ratio with the wide color gamut
 SVA(Super Vertical align) mode
 Wide Viewing angle($\pm 178^\circ$)
 High speed response
 HD resolution(16:9)
 Low Power consumption
 wLED 1side edge BLU
 DE(Data enable) mode
 The interface(1pixel/clock) of 1ch LVDS(Differential signaling with a low voltage)

APPLICATIONS

Home-alone Multimedia TFT-LCD TV
 High Definition TV

GENERAL INFORMATION

Items	Specification	Unit	Note
Module Size	534.0 (H) x 311.8 (V)	mm	± 0.5
	11.1 (Dmax)		w/o converter
Weight	2100	g	max
Pixel Pitch	0.372(H) x 0.372(W)	mm	
Active Display Area	508.152(H) X 285.696 (V)	mm	
Surface Treatment	Anti Glare		
Display Colors	8bit - 16.7M	colors	
Number of Pixels	1366 x 768	pixel	16 : 9
Pixel Arrangement	RGB vertical stripe		
Display Mode	Normally Black		
Luminance of White	250	cd/m ²	

SAMSUNG DISPLAY

1. ABSOLUTE MAXIMUM RATINGS

1.1 ENVIRONMENTAL ABSOLUTE RATINGS

Item	Symbol	Min.	Max.	Unit	Note
Power supply voltage	VDD	GND-0.3	13.2	V	(1)
Storage temperature	TSTG	-20	60	°C	(1)
Operating temperature	TOPR	0	50	°C	(1)
Shock (non-operating)	Snop(X,Y,Z)	-	50	G	(2), (4)
Vibration (non-operating)	Vnop		1.5	G	(3), (4)

Note (1) The ranges of temperature and relative humidity are shown in the graph below. 90% RH Max.
(The temperature of Ta shall be over 39°C.)

The maximum temperature of wet-bulb shall be less than 39°C.

No condensation

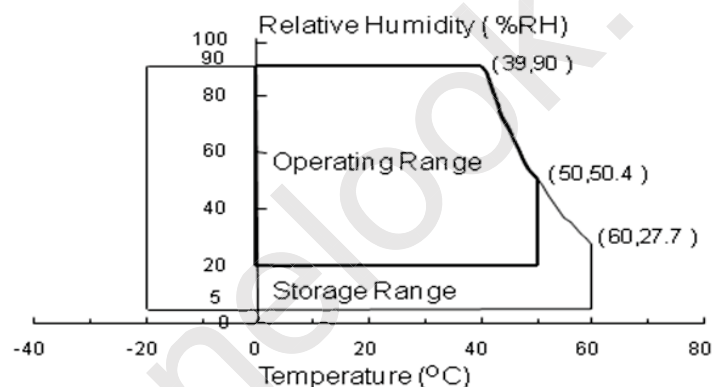

Note (2) 20ms, one time for $\pm X, \pm Y, \pm Z$ axis

Note (3) 10-300 Hz, Sweep rate 11min, 30min for X,Y,Z axis

Note (4) The fixture for the test of the vibration and shock, which holds the module to be tested shall be hard and rigid in order for the module not to be twisted or bent by the fixture.

SAMSUNG DISPLAY

2. OPTICAL CHARACTERISTICS

The optical characteristics shall be measured in the dark room or the space surrounded by the similar ambient setting.

Measuring equipment : TOPCON RD-80S, TOPCON SR-3, ELDIM EZ-Contrast

$T_a = 25 \pm 2 \text{ }^\circ\text{C}$, $V_{DD} = 12\text{V}$, $f_v = 60\text{Hz}$, $f_{DCLK} = 78\text{MHz}$, $IF = 100\%$ duty

Item	Sym bol	Condition	Min.	Typ.	Max.	Unit	Note	
Contrast Ratio	CR		3000	4000	-	-	(1) SR-3	
Respo nse time	G-to-G	T_g	$T_{PAN.SUR} = 29.9\text{ }^\circ\text{C}$	-	8	16	msec	(3) RD-80S
Luminance of White (At the center of screen)	Y_L		200	250	-	cd/m^2	(4) SR-3	
Color Chromat icity (CIE 1931)	Red	R_x	Normal $\phi = 0$ $\theta = 0$ Viewing Angle	-0.03	0.645	+0.03	-	(5),(6) SR-3
		R_y			0.338			
	Green	G_x			0.302			
		G_y			0.603			
	Blue	B_x			0.149			
		B_y			0.067			
	White	W_x			0.285			
		W_y			0.311			
Color Gamut	-	-	-	68	-	%	(5) SR-3	
Color temperature	-	-	-	8500	-	K		
Viewing Angle	Hor.	θ_L	$CR \geq 10$	70	85	-	Degree	(6) SR-3 EZ-Contrast
		θ_R		70	85	-		
	Ver.	ϕ_U		70	80	-		
		ϕ_D		70	80	-		
Brightness Uniformity (9 Point)	B_{uni}	-	-	-	30	%	(2) SR-3	

SAMSUNG DISPLAY

- Test equipment for setup

The measurement shall be executed under the condition including a stable, windless and dark room for 40min or 60min with lighting the back-light at the given temperature, which is suitable to stabilize the back-light.

The module shall be measured at the center of screen.

The ideal temperature for setup shall be the value derived from the formula, $T_a = 25 \pm 2 \text{ }^\circ\text{C}$.

Note (1) Definition of Viewing angle : The range of Viewing angle ($10 \leq C/R$)

: Ratio of max. gray (Gmax) & min. gray (Gmin) at the center point of the panel

$$C/R = \frac{G_{\max}}{G_{\min}}$$

Gmax : Luminance in all white pixels
Gmin : Luminance in all black pixels.

Note (2) Definition of brightness uniformity at 9 points (Test pattern : Full white)

$$B_{uni} = 100 * \frac{(B_{\max} - B_{\min})}{B_{\max}}$$

Bmax : Maximum brightness
Bmin : Minimum brightness

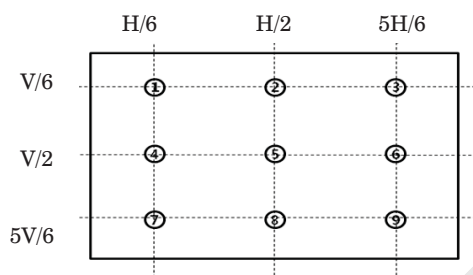

H : Horizontal length of Active Area
V : Vertical height of Active Area.

Note (3) Definition of response time : Sum of T_r , T_f

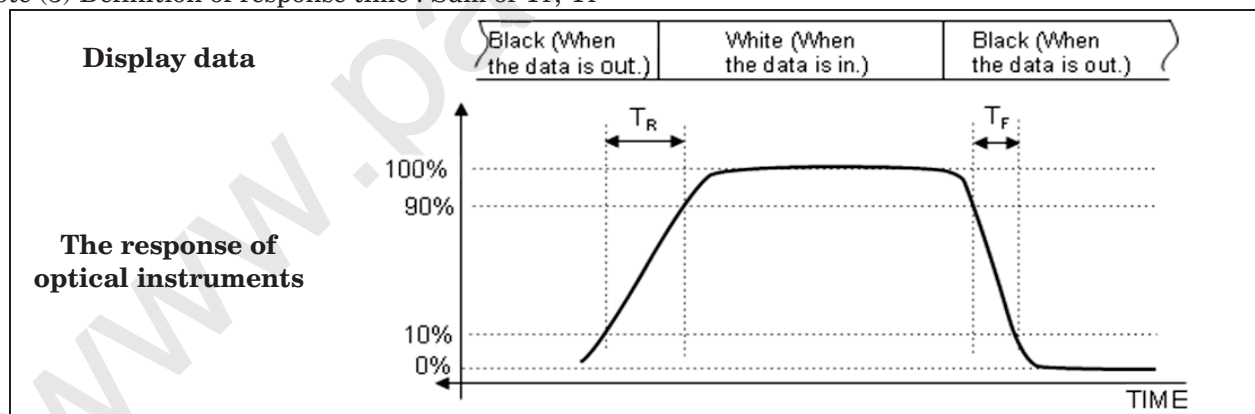

※ G-to-G : Average response time between the whole gray scale to the whole gray scale.

SAMSUNG DISPLAY

Note (4) The definition of luminance of white: The luminance of white at the center point ⑤

Note (5) The definition of chromaticity (CIE 1931)

The color coordinate of red, green, blue and white at the center point ⑤

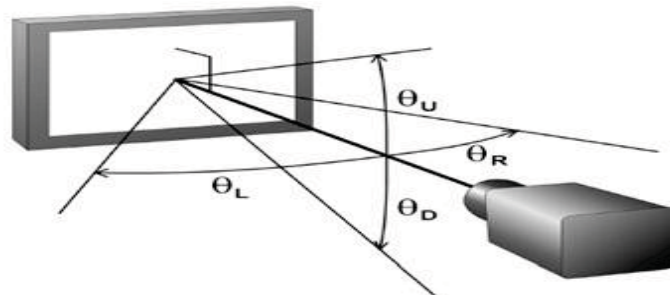

Note (6) Definition of viewing angle : The range of viewing angle (C/R ≥ 10)

www.panelook.com

SAMSUNG DISPLAY

3. ELECTRICAL CHARACTERISTICS

3.1 TFT LCD MODULE

The connector to transmit a display data and a timing signal shall be connected.

* Ta = 25 ± 2 °C

Item	Symbol	Min.	Typ.	Max.	Unit	Note
Voltage of Power Supply	V _{DD}	10.8	12.0	13.2	V	(1)
Current of Power Supply	(a) Black	-	313	415	mA	(2), (3)
	(b) White	-	305	410		
	(c) V- Stripe	-	559	660		
Vsync Frequency	f _v	50	60	66	Hz	-
Hsync Frequency	f _H	44	48	53	kHz	-
Main Frequency	F _{delk}	72	78	85	MHz	-
Rush Current	I _{RUSH}	-	-	4	A	(4)

Note (1) The voltage for ripple shall be controlled under the range, which is lower than 10% of V_{DD} voltage.

Note (2) f_V=60Hz, f_{DCLK} = 78MHz, V_{DD} = 12.0V, DC Current.

Note (3) The pattern for checking the power dissipation (LCD module only)

a) Black Pattern



b) White Pattern



c) V-stripe

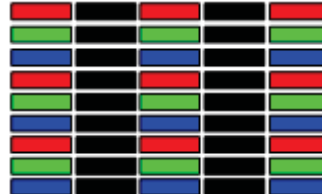

Note (4) Conditions for measurement

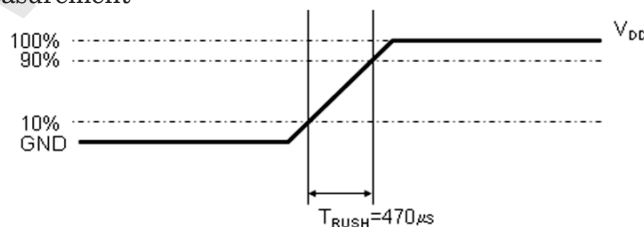

The rush current, I_{RUSH} can be measured when T_{RUSH} is 470μs.

SAMSUNG DISPLAY

3.2 BACK LIGHT UNIT

Item	Symbol	Min.	Typ.	Max.	Unit	Note
Operating Temperature range	Top	-20	-	70	°C	Note (1)
Storage Temperature range	Tstg	-30	-	85	°C	
Junction Temperature	Tj	-	-	145	°C	
LED Forward Current	IF	-	120	125	mA	Continuous operation @String Operating Current 120mA
LED Forward Voltage	VF	-	3.05	3.3	V	Continuous operation @String
Thermal Resistance Junction to PCB	Rth, JS	-	-	23	K/W	Note (1)
Power Consumption	P	-	12.1	13.6	W	IF X VF X 3ch
Operating Life Time	Hr	30,000	-	-	Hour	Note (2)
LED Counts	Q	-	33	-	EA	

Note (1) LED unit absolute rating

Note (2) It is defined as the time to take until the brightness reduces to 50% of its original value.

Operating condition : Ta = 25±2 °C, for LED package only.

3.3 Converter connection cable

pin	Pin name	Description
1	Vin	LED power input
2	RTN1	LED bar return channel 1
3	RTN2	LED bar return channel 2
4	RTN3	LED bar return channel 3

SAMSUNG DISPLAY

4. INPUT TERMINAL PIN ASSIGNMENT

4.1 INPUT SIGNAL & POWER

Connector : IS100-L300-C23

INPUT CONNECTOR PIN MAP				
NO	PIN	NO	PIN	
1	VIN	16	LV1_P	
2	VIN	17	GND	
3	VIN	18	LV2_N	
4	VIN	19	LV2_P	
5	NC	20	GND	
6	GND	21	LVCLK_N	
7	GND	22	LVCLK_P	
8	NC	23	GND	
9	LVDS_SEL	24	LV3_N	
10	NC	25	LV3_P	
11	GND	26	GND	
12	LV0_N	27	NC	
13	LV0_P	28	NC	
14	GND	29	NC	
15	LV1_N	30	GND	

NOTE (1) NC : Not connection, PINs are used SDC only

NOTE (2) LVDS Option : If this pin is high (3.3V) → Normal LVDS format
Low (GND) → JEIDA LVDS format

NOTE (3) : Pin number, which starts from the left side.

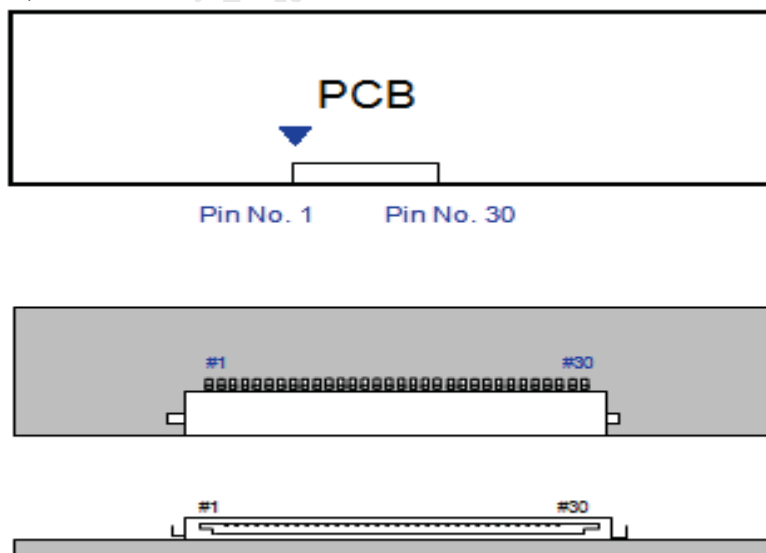

Fig. Connector diagram

- Pins for power GND shall be connected to the LCD's metal chassis.
- All input pins for power shall be connected together.
- All NC pins shall be designed with being separated from other signal or power.

SAMSUNG DISPLAY

4.2 LVDS INTERFACE

- LVDS Receiver : T-CON (merged)
- Data Format(JEIDA & VESA)

	LVDS pin	JEIDA -DATA	VESA -DATA
TxOUT/RxIN0	TxIN/RxOUT0	R2	R0
	TxIN/RxOUT1	R3	R1
	TxIN/RxOUT2	R4	R2
	TxIN/RxOUT3	R5	R3
	TxIN/RxOUT4	R6	R4
	TxIN/RxOUT6	R7	R5
	TxIN/RxOUT7	G2	G0
TxOUT/RxIN1	TxIN/RxOUT8	G3	G1
	TxIN/RxOUT9	G4	G2
	TxIN/RxOUT12	G5	G3
	TxIN/RxOUT13	G6	G4
	TxIN/RxOUT14	G7	G5
	TxIN/RxOUT15	B2	B0
	TxIN/RxOUT18	B3	B1
TxOUT/RxIN2	TxIN/RxOUT19	B4	B2
	TxIN/RxOUT20	B5	B3
	TxIN/RxOUT21	B6	B4
	TxIN/RxOUT22	B7	B5
	TxIN/RxOUT24	HSYNC	HSYNC
	TxIN/RxOUT25	VSYNC	VSYNC
	TxIN/RxOUT26	DEN	DEN
TxOUT/RxIN3	TxIN/RxOUT27	R0	R6
	TxIN/RxOUT5	R1	R7
	TxIN/RxOUT10	G0	G6
	TxIN/RxOUT11	G1	G7
	TxIN/RxOUT16	B0	B6
	TxIN/RxOUT17	B1	B7
	TxIN/RxOUT23	RESERVED	RESERVED

SAMSUNG DISPLAY

4.3 INPUT SIGNALS, BASIC DISPLAY COLORS AND GRAY SCALE

Note (1) Definition of gray : Rn: Red gray, Gn: Green gray, Bn: Blue gray (n=gray level)

Note (2) Input signal: 0 =Low level voltage, 1=High level voltage

COLOR	DISPLAY (8bit)	DATA SIGNAL																												GRAY SCALE LEVEL
		RED								GREEN								BLUE												
		R0	R1	R2	R3	R4	R5	R6	R7	G0	G1	G2	G3	G4	G5	G6	G7	B0	B1	B2	B3	B4	B5	B6	B7					
BASIC COLOR	BLACK	0	0	0	0	0	0	0	0	0	0	0	0	0	0	0	0	0	0	0	0	0	0	0	0	0	0	0	-	
	BLUE	0	0	0	0	0	0	0	0	0	0	0	0	0	0	0	0	0	1	1	1	1	1	1	1	1	1	1	-	
	GREEN	0	0	0	0	0	0	0	0	1	1	1	1	1	1	1	1	1	0	0	0	0	0	0	0	0	0	0	-	
	CYAN	0	0	0	0	0	0	0	0	1	1	1	1	1	1	1	1	1	1	1	1	1	1	1	1	1	1	1	-	
	RED	1	1	1	1	1	1	1	1	0	0	0	0	0	0	0	0	0	0	0	0	0	0	0	0	0	0	0	-	
	MAGENTA	1	1	1	1	1	1	1	1	0	0	0	0	0	0	0	0	0	1	1	1	1	1	1	1	1	1	1	-	
	YELLOW	1	1	1	1	1	1	1	1	1	1	1	1	1	1	1	1	0	0	0	0	0	0	0	0	0	0	0	-	
	WHITE	1	1	1	1	1	1	1	1	1	1	1	1	1	1	1	1	1	1	1	1	1	1	1	1	1	1	1	-	
GRAY SCALE OF RED	BLACK	0	0	0	0	0	0	0	0	0	0	0	0	0	0	0	0	0	0	0	0	0	0	0	0	0	0	R0		
	DARK ↑	1	0	0	0	0	0	0	0	0	0	0	0	0	0	0	0	0	0	0	0	0	0	0	0	0	0	R1		
		0	1	0	0	0	0	0	0	0	0	0	0	0	0	0	0	0	0	0	0	0	0	0	0	0	0	R2		
		:	:	:	:	:	:	:	:	:	:	:	:	:	:	:	:	:	:	:	:	:	:	:	:	:	:	R3~R252		
		:	:	:	:	:	:	:	:	:	:	:	:	:	:	:	:	:	:	:	:	:	:	:	:	:	:			
		↓ LIGHT	1	0	1	1	1	1	1	1	0	0	0	0	0	0	0	0	0	0	0	0	0	0	0	0	0	0	R253	
	0	1	1	1	1	1	1	1	1	0	0	0	0	0	0	0	0	0	0	0	0	0	0	0	0	0	0	R254		
RED	1	1	1	1	1	1	1	1	0	0	0	0	0	0	0	0	0	0	0	0	0	0	0	0	0	0	R255			
GRAY SCALE OF GREEN	BLACK	0	0	0	0	0	0	0	0	0	0	0	0	0	0	0	0	0	0	0	0	0	0	0	0	0	0	G0		
	DARK ↑	0	0	0	0	0	0	0	0	1	0	0	0	0	0	0	0	0	0	0	0	0	0	0	0	0	0	G1		
		0	0	0	0	0	0	0	0	0	1	0	0	0	0	0	0	0	0	0	0	0	0	0	0	0	0	G2		
		:	:	:	:	:	:	:	:	:	:	:	:	:	:	:	:	:	:	:	:	:	:	:	:	:	:	G3~G252		
		:	:	:	:	:	:	:	:	:	:	:	:	:	:	:	:	:	:	:	:	:	:	:	:	:	:			
		↓ LIGHT	0	0	0	0	0	0	0	0	1	0	1	1	1	1	1	1	1	0	0	0	0	0	0	0	0	0	G253	
	0	0	0	0	0	0	0	0	0	0	1	1	1	1	1	1	1	1	0	0	0	0	0	0	0	0	0	G254		
GREEN	0	0	0	0	0	0	0	0	1	1	1	1	1	1	1	1	1	0	0	0	0	0	0	0	0	0	G255			
GRAY SCALE OF BLUE	BLACK	0	0	0	0	0	0	0	0	0	0	0	0	0	0	0	0	0	0	0	0	0	0	0	0	0	0	B0		
	DARK ↑	0	0	0	0	0	0	0	0	0	0	0	0	0	0	0	0	0	1	0	0	0	0	0	0	0	0	B1		
		0	0	0	0	0	0	0	0	0	0	0	0	0	0	0	0	0	0	1	0	0	0	0	0	0	0	B2		
		:	:	:	:	:	:	:	:	:	:	:	:	:	:	:	:	:	:	:	:	:	:	:	:	:	:	B3~B252		
		:	:	:	:	:	:	:	:	:	:	:	:	:	:	:	:	:	:	:	:	:	:	:	:	:	:			
		↓ LIGHT	0	0	0	0	0	0	0	0	0	0	0	0	0	0	0	0	0	1	0	1	1	1	1	1	1	1	B253	
	0	0	0	0	0	0	0	0	0	0	0	0	0	0	0	0	0	0	0	1	1	1	1	1	1	1	1	B254		
BLUE	0	0	0	0	0	0	0	0	0	0	0	0	0	0	0	0	0	1	1	1	1	1	1	1	1	1	B255			

SAMSUNG DISPLAY

5. INTERFACE TIMING

5.1 THE PARAMETERS OF TIMING(DE mode)

SIGNAL	ITEM	SMBOL	MIN.	TYP.	MAX.	Unit	NOTE
Clock	Frequency	$1/T_C$	72	78	85	MHz	-
Hsync		F_H	44	48	53	KHz	-
Vsync		F_V	50	60	66	Hz	-
Term for the vertical display	Active display period	T_{VD}	-	768	-	Lines	-
	Total vertical	T_V	775	802	1200	Lines	-
Term for the horizontal display	Active display period	T_{HD}	-	1366	-	Clocks	-
	Total Horizontal	T_H	1460	1624	2000	clocks	-

Note) The signals of Hsync and Vsync must be inputted even though this T-con is operated with DE signal only.

(1) Test Point: TTL controls signals and CLKs at LVDS Tx at the input terminal of system.

(2) Internal VDD = 3.3V

(3) The spread spectrum

- The limit of spread spectrum's range of SET in which the LCD module is assembled should be within $\pm 3\%$
- Frequency for modulation : Min 30KHz

Parameter		Symbol	Value			Unit	Note
			Min	Typ	Max		
CMOS Interface	Input High Threshold Voltage	V_{IH} (High)	2.5	-	3.3	V	
	Input Low Threshold Voltage	V_{IL} (Low)	0	-	0.5	V	

SAMSUNG DISPLAY

5.2 TIMING DIAGRAMS OF INTERFACE SIGNAL(Only DE mode)

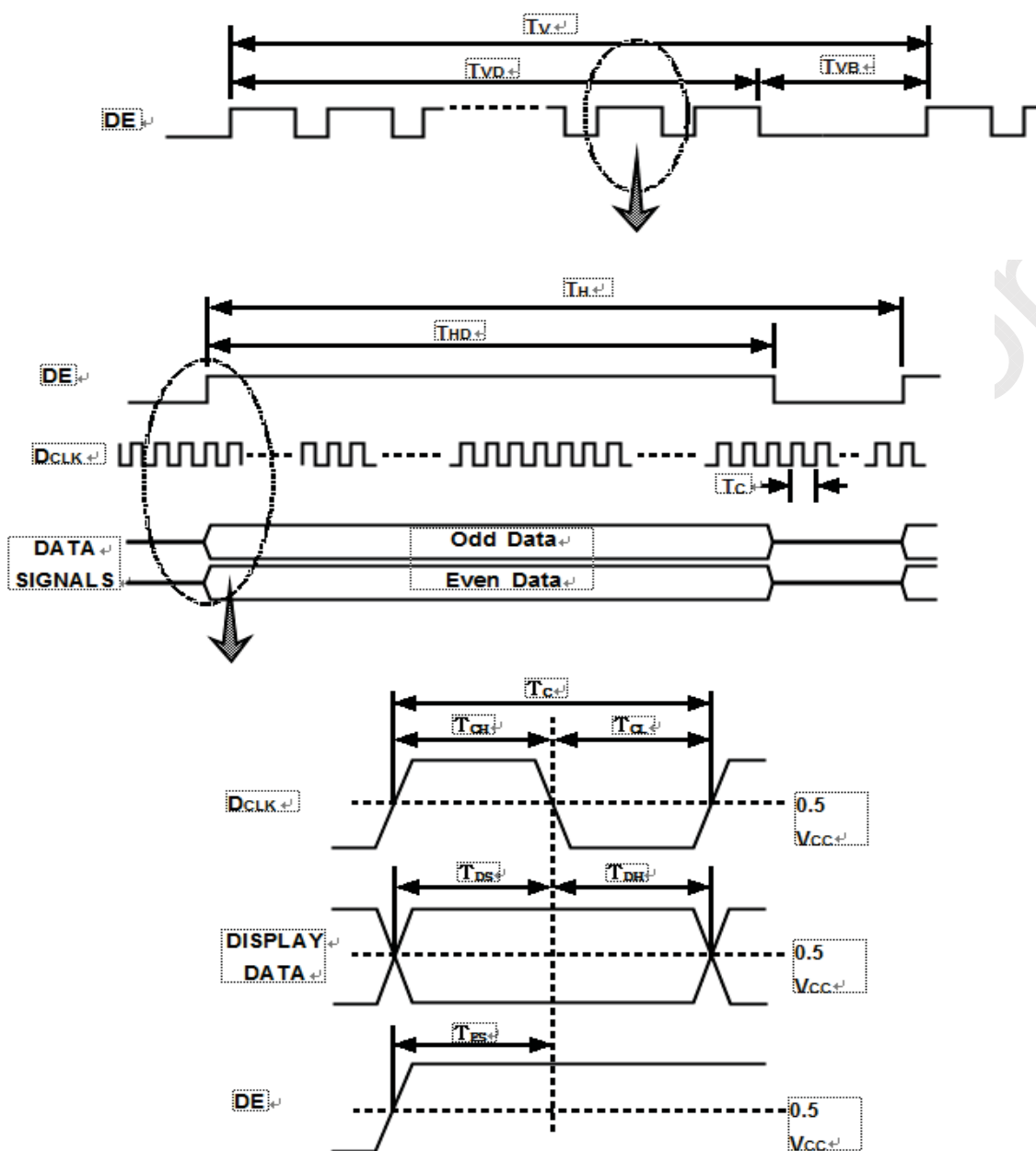

SAMSUNG DISPLAY

5.3 CHARACTERISTICS OF INPUT DATA OF LVDS

(1) LVDS characteristics

	ITEM	SYMBOL	Min	Typ	Max	Unit	Note
DC characteristics	Supply voltage	V_{DD}	3.0	3.3	3.6	V	
	Input Common mode Voltage	V_{CM}	0.3		1.8	V	
	Differential Input Voltage	$ V_{ID} $	100		600	mV	
AC characteristics	Input data position	T_{RSRM}	-	-	450	ps	$F_{IN} = 78\text{MHz}$
		T_{RSLM}	-450	-	-	ps	

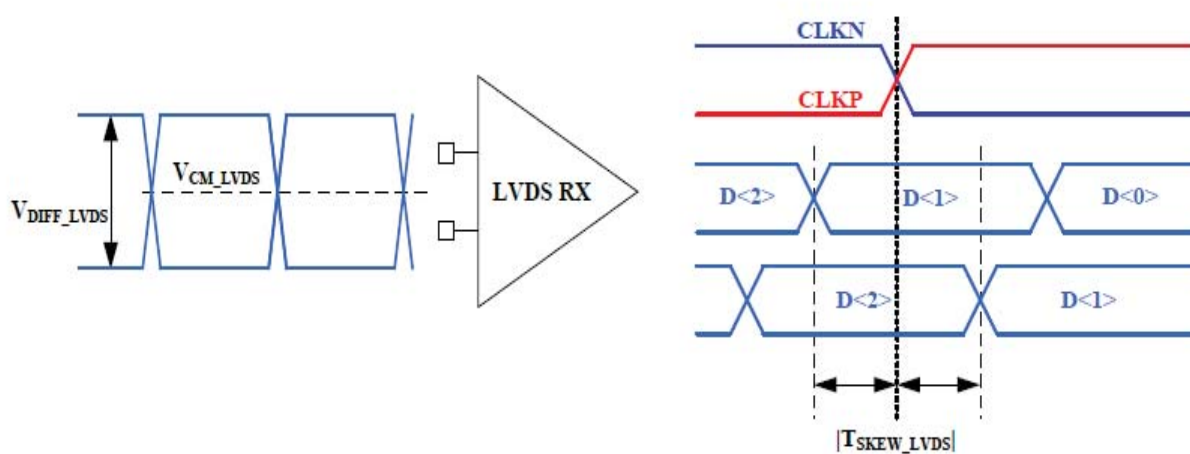

SAMSUNG DISPLAY

5.4 THE SEQUENCE OF POWER ON AND OFF

To prevent the product from being latched up or the DC in the LCD module from starting an operation, the order to turn the power on and off should be changed to the order as shown in the diagram below.

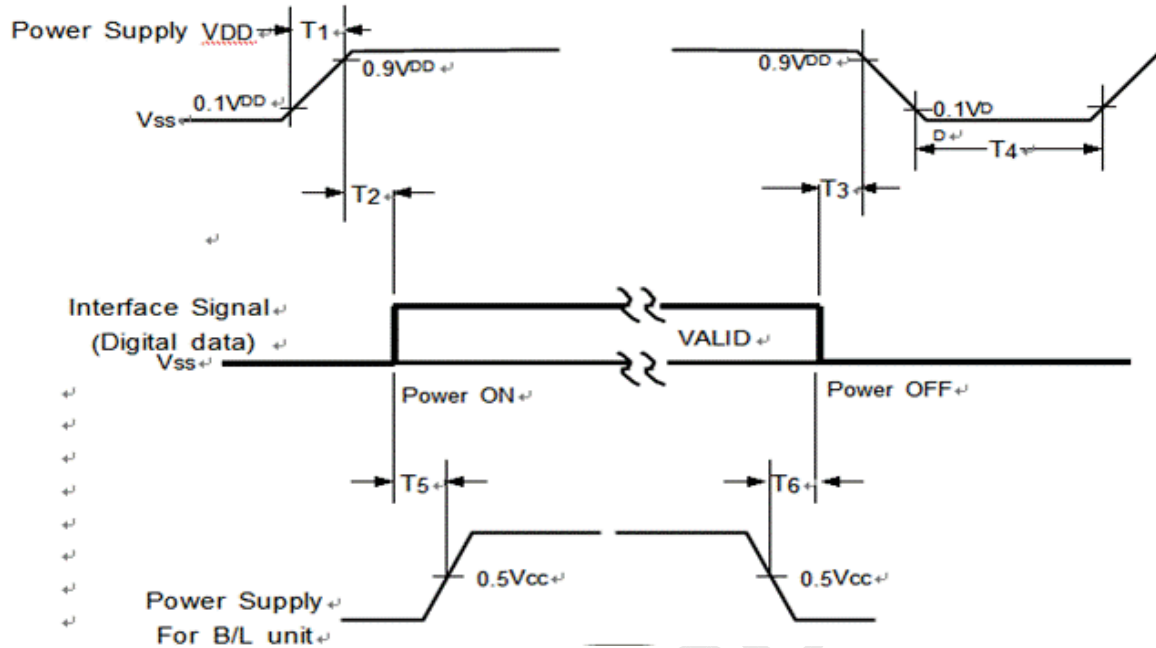

Timing	Spec	Remarks
T ₁	0.5 msec < T ₁ ≤ 10msec	The time, during which the level of V _{DD} is rising from 10% to 90%.
T ₂	10 msec < T ₂ ≤ 50msec	The changing time, during which the V _{DD} starts rising beyond 90% until the valid data of signal started coming in.
T ₃	0msec < T ₃ ≤ 50msec	The changing time, during which the valid data of signal starts leaving out until the V _{DD} starts falling below 90%.
T ₄	1000msec ≤ T ₄	The changing time, during which the V _{DD} starts falling below 10% to restart the Windows.
T ₅	1000msec ≤ T ₅ (BLU ON TIME)	The changing time, during which the signal of BLU starts rising beyond 50%.
T ₆	100msec ≤ T ₆	The changing time, during which the signal of BLU starts falling below 50%.

- The inputted V_{DD}'s value for supply voltage, BLU, and signal to the external system of the module shall be computed with referring to the former mentioned value.
- The method to apply the voltage to the lamp within the range, which the LCD operates. When the back-light is turned on before the LCD is operated or the power of LCD is turned off before the back-light is turned off, the abnormal display on the screen may be shown momentarily.
- Please keep the level of input signal low or keep the level of impedance high when the value of V_{DD} is below 10%.
- The value shall be measured after the module has been fully discharged between the period, which the power is turned on and the period, which the power is turned off like the T₄ timing. The backlight may be flashed if the interface signal remains floated when the above-mentioned signal becomes invalid.

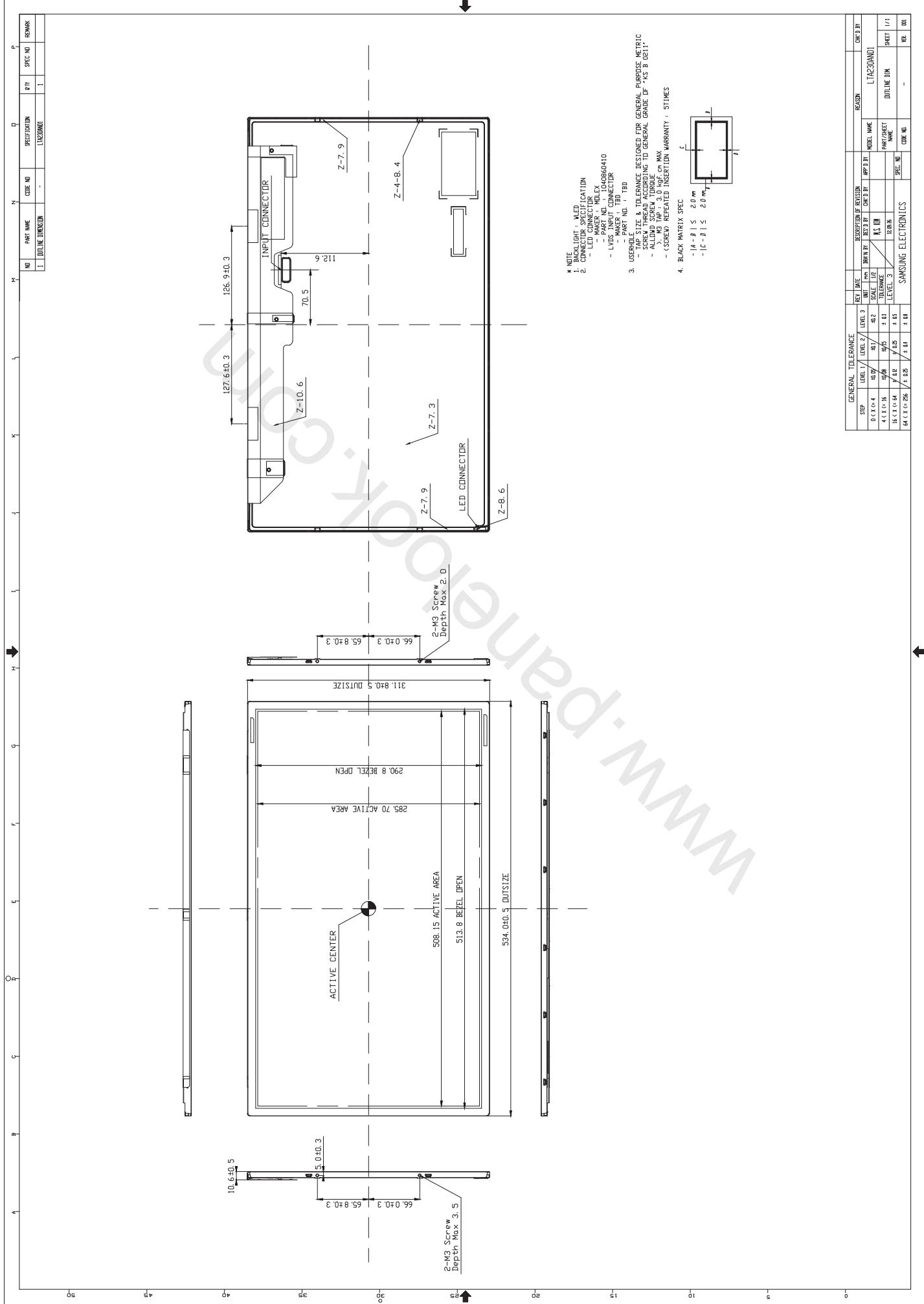

- NOTE**
1. BACKLIGHT: WLED
 2. CONNECTOR SPECIFICATION:
 - LED CONNECTOR: MOLEX
 - LED CONNECTOR: MOLEX
 - LED CONNECTOR: MOLEX
 - LED CONNECTOR: MOLEX
 - LED CONNECTOR: MOLEX
 - LED CONNECTOR: MOLEX
 3. USING: PART NO. 1: TBD
 - TAP SIZE & TOLERANCE DESIGNED FOR GENERAL PURPOSE METRIC SCREW THREAD ACCORDING TO GENERAL GRADE DF *KS B 0211*
 - (SCREW) REPEATED INSERTION WARRANTY: 5 TIMES
 4. BLACK MATRIX SPEC:
 - |A - B| ≤ 2.0mm
 - |C - D| ≤ 2.0mm

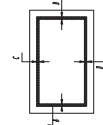

GENERAL TOLERANCE		DESCRIPTION OF RESOLUTION		REASON	
STEP	LEVEL	UNIT	MIN	MAX	REASON
0.X.X ± 0.4	±0.2	mm			LTA230A0D
4.X.X ± 0.16	±0.08	mm			DRAWING
16.X.X ± 0.64	±0.32	mm			DRAWING
64.X.X ± 2.56	±1.28	mm			DRAWING

REV	DATE	DESCRIPTION OF RESOLUTION	APP BY	CHK BY	REASON
1					

MODEL NAME	PART/SET NAME	SPEC. NO.	CODE NO.	REV.	DATE
				001	

SAMSUNG DISPLAY

7. PACKING

(1) Packing Form

Corrugated Cardboard box as shock absorber.

(2) Packing Method

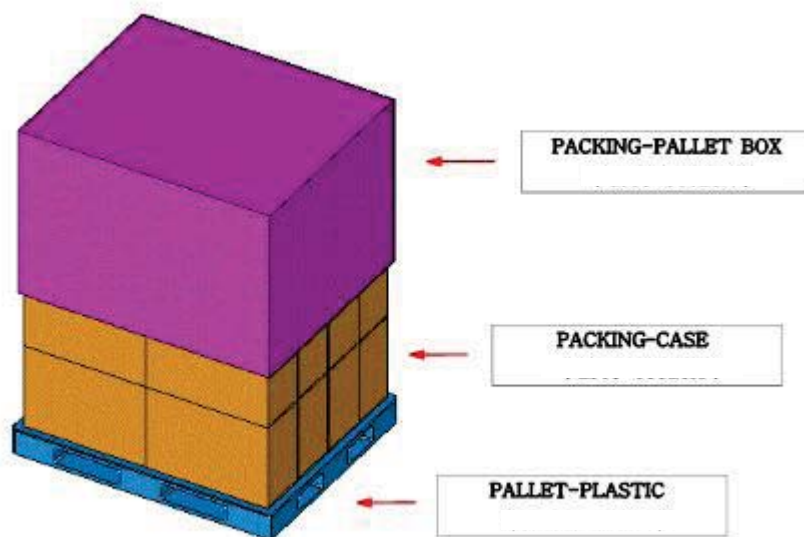

Item	Specification	Remark
LCD Packing	12ea / Box	21Kg/ LCD (12ea) 
Pallet	16Box / Pallet	Pallet weight : 8.8Kg
Packing Direction	Vertical	
Total Pallet Size	H x V x height	1270mm(H) x 1072mm(V) x 865mm (h: with pallet)
Total Pallet Weight	345Kg	Pallet + Module + Cushion + Pallet box



SAMSUNG DISPLAY

8. MARKINGS & OTHERS

A nameplate is affixed to the specified location on each product.

- (1) Parts number : LTA230AN01
- (2) Revision code : 3 letters
- (3) Lot number : XXXXXXXXXXXX

(4) Nameplate Indication

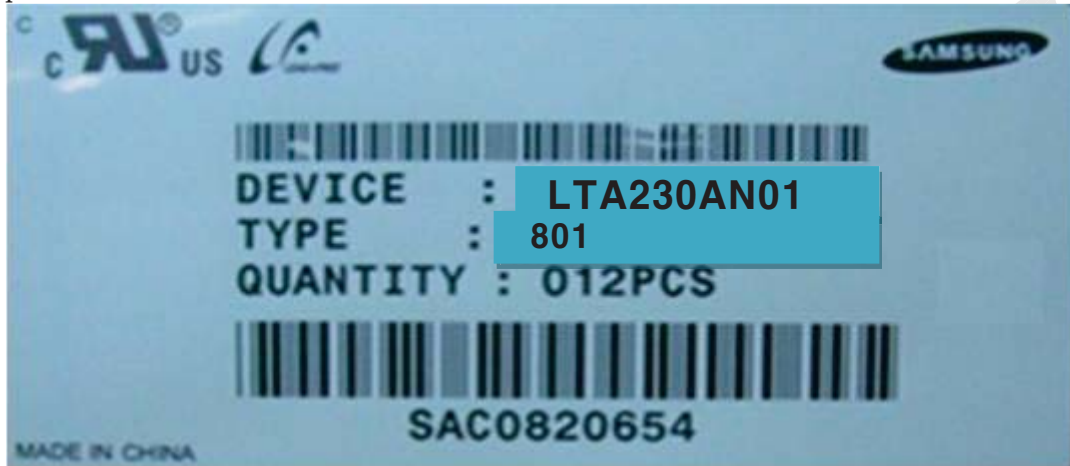

Parts name : LTA230AN01
 Lot number : XXXXXXXXXXXX
 Week code : 1230 (2012 year 30th week)
 Product Revision Code : 801

(5) Packing small box attach



Parts name : LTA230AN01
 Box serial number : ZAT53K0003

SAMSUNG DISPLAY

9. GENERAL PRECAUTIONS

9.1 HANDLING

- (a) When the module is assembled, It should be attached to the system firmly using every mounting holes. Be careful not to twist and bend the module.
- (b) Refrain from strong mechanical shock and / or any force to the module. In addition to damage, this may cause improper operation or damage to the module and LED back-light.
- (c) Note that polarizers are very fragile and could be easily damaged. Do not press or scratch the surface harder than a HB pencil lead.
- (d) Wipe off water droplets or oil immediately. If you leave the droplets for a long time, Staining and discoloration may occur.
- (e) If the surface of the polarizer is dirty, clean it using some absorbent cotton or soft cloth.
- (f) The desirable cleaners are water, IPA (Isopropyl Alcohol) or Hexane. Do not use Ketone type materials(ex. Acetone), Ethyl alcohol, Toluene, Ethyl acid or Methyl chloride. It might permanent damage to the polarizer due to chemical reaction.
- (g) If the liquid crystal material leaks from the panel, it should be kept away from the eyes or mouth .In case of contact with hands, legs or clothes, it must be washed away thoroughly with soap.
- (h) Protect the module from static , it may cause damage to the C-MOS Gate Array IC.
- (i) Use fingerstalls with soft gloves in order to keep display clean during the incoming inspection and assembly process.
- (j) Do not disassemble the module.
- (k) Do not pull or fold the LED FPC.
- (l) Do not touch any component which is located on the back side.
- (m) Protection film for polarizer on the module shall be slowly peeled off just before use so that the electrostatic charge can be minimized.
- (n) Pins of I/F connector shall not be touched directly with bare hands.
- (o) Because the converter use high voltage, it should be disconnected from power before it is assembled or disassembled.

SAMSUNG DISPLAY

9.2 STORAGE

We highly recommend to comply with the criteria in the table below.

ITEM	Unit	Min.	Max.
Storage Temperature	(°C)	5	40
Storage Humidity	(%rH)	35	75
Storage Life	12 months		
Storage Condition	<ul style="list-style-type: none"> - The storage room should be equipped with a good ventilation facility, which has a temperature controlling system. - Products should be placed on the pallet, which is away from the wall not on the floor. - Prevent products from being exposed to the direct sunlight, moisture, and water.; Be cautious not to pile the products up. - Avoid storing products in the environment, which other hazardous material is placed. - If products are delivered or kept in the storage facility more than 3 months, we recommend you to leave products under the condition including a 20°C temperature and a humidity of 50% for 24 hours. - If you store semi-manufactured products for more than 3 months, bake the products under the condition including the 50°C temp. and the 10% humidity for 24hrs after being used. 		

9.3 OPERATION

- (a) Do not connect or disconnect the cable to/ from the module at the "Power On" condition.
- (b) The power shall be always turned on/off by the item 6.5. "Power on/off sequence"
- (c) The module has a circuit with a high frequency. The system manufacturers shall suppress the electromagnetic interference sufficiently. The methods to ground and shield are important to minimize the interference.
- (d) Design the length of cable to connect between the connector for back-light and the Converter as short as possible and the shorter cable shall be connected directly.
The longer cable between that of back-light and that of Converter may cause the luminance of LED package to lower and need a higher startup voltage(Vs).

SAMSUNG DISPLAY

9.4 Operation Condition Guide

- (a) The LCD product should be operated under normal conditions. Normal condition is defined as below;
- Temperature : $20 \pm 15^{\circ}\text{C}$
 - Humidity : $55 \pm 20\%$
 - Display pattern : continually changing pattern (Not stationary)

(b) If the product will be used in extreme conditions such as high temperature, humidity, display patterns or operation time etc., It is strongly recommended to contact SDC for Application engineering advice. Otherwise, its reliability and function may not be guaranteed. Extreme conditions are commonly found at Airports, Transit Stations, Banks, Stock market, and Controlling systems.

9.5 OTHERS

- (a) The filter for ultra-violet ray is needed when you operate a product outdoor.
- (b) Avoid placing the product in the environment, which water is condensed. The former mentioned condition may lead a product to operate improperly or an electrode to be disconnected.
- (c) Do not exceed the ceiling of absolute maximum rating. (Various supply voltages, Various input voltages, Various contents on the part, various environmental temperatures, and so on) Otherwise, the module may be damaged.
- (d) If the module displays the same pattern for a long time, the situation can be the image sticking to the screen.
- (e) This module shall be handled carefully in order not to be stressed by the object from outside since this module contains a circuitry for PCB on the rear side.