



Samsung Secret

Approval specification

Customer : HISENSE



DATE : Aug. 31. 2010

SAMSUNG TFT-LCD

MODEL : LTA460HQ08

Any modification of the specification is not allowed without the permission of Samsung.

NOTE :

Customer's Approval		APPROVAED BY 	DATE Aug. 31, 2010
		SIGNATURE	DATE
		PREPARED BY 	DATE Aug. 31, 2010

LCD Business

Samsung Electronics Co . , LTD.

MODEL	LTA460HQ08	Doc. No	06-000-G-20100831	Page	1 / 27
-------	------------	---------	-------------------	------	--------

Samsung Secret**Contents**

Revision History	-----	(3)
General Description	-----	(4)
General Information	-----	(4)
1. Absolute Maximum Ratings	-----	(5)
2. Optical Characteristics	-----	(6)
3. Electrical Characteristics	-----	(9)
3.1 TFT LCD Module		
3.2 Back Light Unit		
3.3 Converter Input & Specification		
4. Input Terminal Pin Assignment	-----	(12)
4.1 Input Signal & Power		
4.2 Converter Input Pin Configuration		
4.3 Converter Input Power Sequence		
4.4 LVDS Interface		
4.5 Input Signals, Basic Display Colors and Gray Scale of Each Color		
5. Interface Timing	-----	(17)
5.1 Timing Parameters (DE only mode)		
5.2 LVDS Input data Characteristics		
5.3 Timing Diagrams of interface Signal (DE only mode)		
5.4 Power ON/OFF Sequence		
6. Outline Dimension	-----	(20)
7. Reliability test	-----	(22)
8. Packing	-----	(23)
9. Marking & Others	-----	(24)
10. General Precaution	-----	(25)
10.1 Handling		
10.2 Storage		
10.3 Operation		
10.4 Operation Condition Guide		
10.5 Others		

MODEL

LTA460HQ08

Doc. No

06-000-G-20100831

Page

2 / 27

Revision History**Samsung Secret**

Date	Rev. No	Page	Summary
Aug. 24. 2010	000	all	First issued

MODEL

LTA460HQ08

Doc. No

06-000-G-20100831

Page

3 / 27

General Description

Samsung Secret

Description

LTA460HQ08 is a color active matrix liquid crystal display (LCD) that uses amorphous silicon TFT (Thin Film Transistor) as switching components. This model is composed of a TFT LCD panel, a driver circuit and a back light unit. The resolution of a 46.0" is 1920 x 1080 and this model can display up to 1.07 Billion colors with wide viewing angle of 89° or higher in all directions. This panel is intended to support applications to provide an excellent performance for Flat Panel Display such as Home-alone Multimedia TFT-LCD TV and High Definition TV

Features

- RoHS compliance (Pb-free)
- High contrast ratio & aperture ratio with wide color gamut
- SPVA (Super Patterned Vertical Align) mode
- Wide viewing angle ($\pm 178^\circ$)
- High speed response (& Natural Motion (DFR: Double Frame Rate))
- FHD resolution (16:9)
- Low Power consumption
- Edge Type LED (Light Emitted Diode) BLU
- DE (Data Enable) mode
- 2ch LVDS (Low Voltage Differential Signaling) interface (2pixel/clock)

General Information

Items	Specification	Unit	Note
Module Size	1076.5 (H) X 634.7 (V)	mm	$\pm 1.0\text{mm}$
	23.9 (max)		
Weight	11500 (Max)	g	
Pixel Pitch	0.53025(H) x 0.53025(W)	mm	
Active Display Area	1018.08 (H) X 572.67 (V)	mm	
Surface Treatment	Antiglare, Hard-coating (3H)		
Display Colors	10 bit – 1.07 Billion	colors	
Number of Pixels	1920 x 1080	pixel	
Pixel Arrangement	RGB vertical stripe		
Display Mode	Normally Black		
Luminance of White	450 (Typ.)	cd/m ²	2D mode only

MODEL

LTA460HQ08

Doc. No

06-000-G-20100831

Page

4 / 27

Samsung Secret

1. Absolute Maximum Ratings

1.1 Back Light Unit Absolute Maximum Ratings

If the condition exceeds maximum ratings, it can cause malfunction or unrecoverable damage to the device.

Item	Symbol	Min.	Max.	Unit	Note
Power Supply Voltage	V_{DD}	GND-0.5	13.2	V	(1)
Dimming Control	Max. Lum	-	5	V	
Storage temperature	T_{STG}	-20	60	°C	(2)
Operating temperature	T_{OPR}	0	50	°C	
Surface temperature	T_{SUR}	0	60	°C	(3)
Shock (non - operating)	S_{NOP}	-	30	G	(4)
Vibration (non - operating)	V_{NOP}	-	1.5	G	(5)

Note (1) $T_a = 25 \pm 2$ °C

(2) Temperature and relative humidity range are shown in the figure below.

a. 90 % RH Max. ($T_a \leq 39$ °C)

b. Relative Humidity is 90% or less. ($T_a > 39$ °C)

c. No condensation

(3) Although abnormal visual problems can be occurred in T_{SUR} range, the polarizer is not damaged in this range.

(4) 11ms, sine wave, one time for $\pm X, \pm Y, \pm Z$ axis

(5) 10-300 Hz, Sweep rate 10min, 30min for X,Y,Z axis

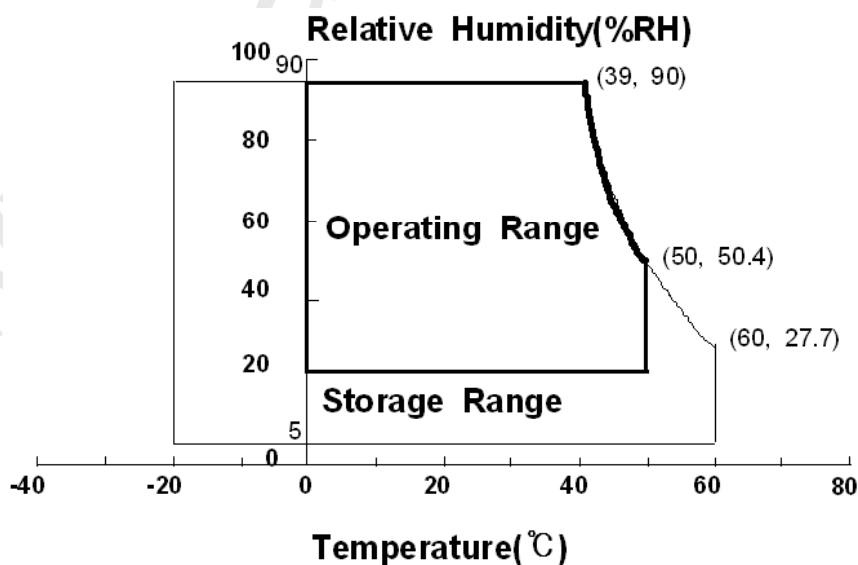

Fig. Temperature and Relative humidity range

MODEL

LTA460HQ08

Doc. No

06-000-G-20100831

Page

5 / 27

2. Optical Characteristics

Samsung Secret

The optical characteristics should be measured in a dark room or equivalent.

Measuring equipment : TOPCON RD-80S, TOPCON SR-3, ELDIM EZ-Contrast

(Ta = 25 ± 2°C, VDD=12V, fv= 60Hz, f_{DCLK} = 148.5MHz, LED Current Duty = 100%,**2D mode Only**)

Item	Symbol	Condition	Min.	Typ.	Max.	Unit	Note
Contrast Ratio (Center of screen)	C/R		3000	4000	-		(1) SR-3
Response Time	G-to-G	Tg	-	6	-	msec	(3) RD-80S
Luminance of White (Center of screen)	Y _L		380	450	-	cd/m ²	(4) SR-3
Color Chromaticity (CIE 1931)	Red	Rx	Normal q _{L,R} = 0 q _{U,D} = 0 Viewing Angle	0.627	TYP. -0.03	TYP. +0.03	(5),(6) SR-3
		Ry		0.334			
	Green	Gx		0.320			
		Gy		0.621			
	Blue	Bx		0.155			
		By		0.049			
	White	Wx		0.280			
		Wy		0.290			
Color Gamut	-		-	72	-	%	(5) SR-3
Color Temperature	-		-	10,000	-	K	(5) SR-3
Viewing Angle	Hor.	q _L	C/R≥10	75	89	-	Degree (6) EZ-Contrast
		q _R		75	89	-	
	Ver.	q _U		75	89	-	
		q _D		75	89	-	
White Brightness Uniformity (9 Points)	B _{uni}		-	-	25	%	(2) SR-3

- Test Equipment Setup

The measurement should be executed in a stable, windless and dark room between 40min and 60min after lighting the back light at the given temperature for stabilization of the back light. This should be measured in the center of screen.

Environment condition : Ta = 25 ± 2 °C

MODEL	LTA460HQ08	Doc. No	06-000-G-20100831	Page	6 / 27
-------	------------	---------	-------------------	------	--------

Samsung Secret

Photo detector	Field
SR-3	2°
RD-80S	1°

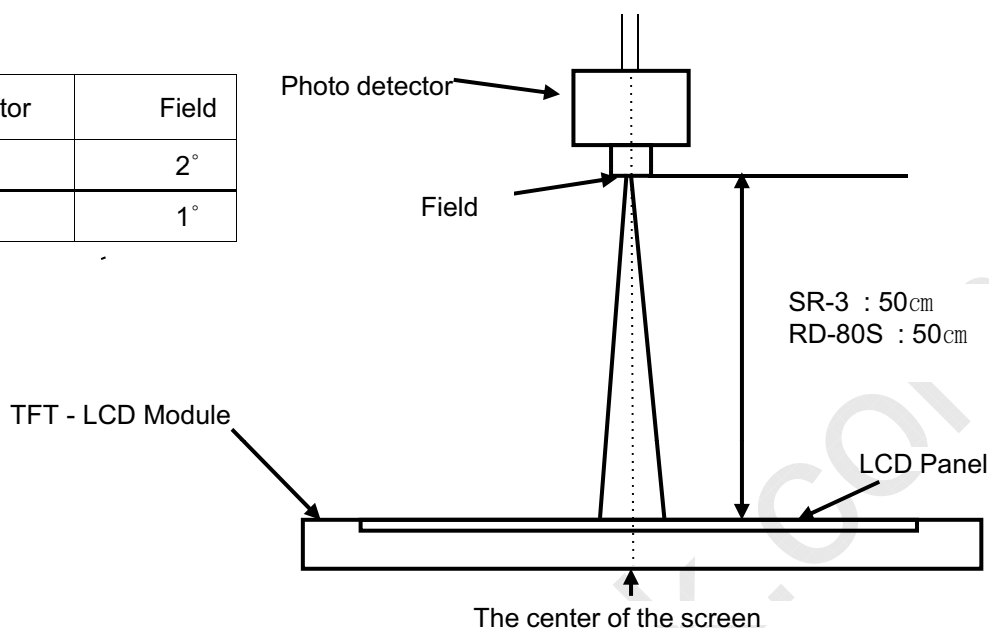

- Definition of test point

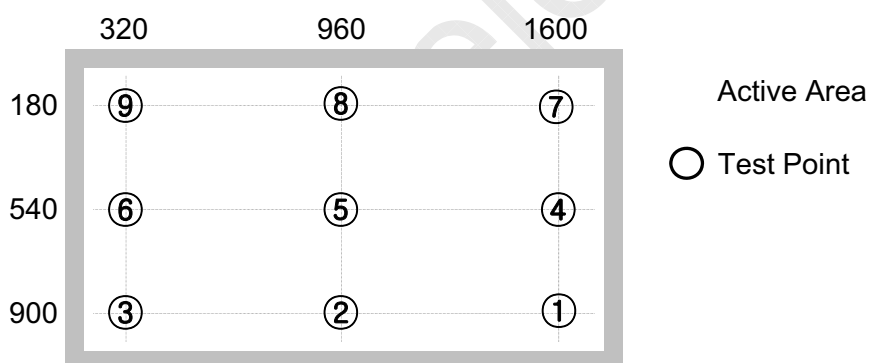

Note (1) Definition of Contrast Ratio (C/R)

: Ratio of gray max (Gmax) & gray min (Gmin) at the center point ⑤ of the panel

$$C/R = \frac{G_{max}}{G_{min}}$$

Gmax : Luminance with all pixels white

Gmin : Luminance with all pixels black

Samsung Secret

Note (2) Definition of 9 points brightness uniformity (Test pattern : Full White)

$$B_{uni} = 100 * \frac{(B_{max} - B_{min})}{B_{max}}$$

Bmax : Maximum brightness

Bmin : Minimum brightness

Note (3) Definition of Response time : Sum of Tr, Tf

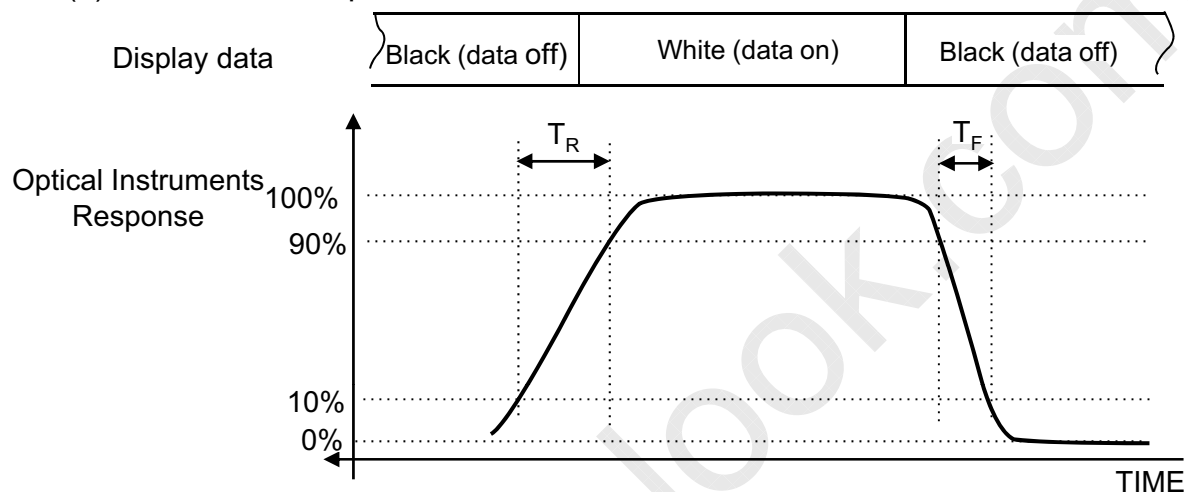

Note (4) Definition of Luminance of White : Luminance of white at center point ⑤

Note (5) Definition of Color Chromaticity (CIE 1931)

Color coordinate of Red, Green, Blue & White at center point ⑤

Note (6) Definition of Viewing Angle

: Viewing angle range (C/R ≥ 10)

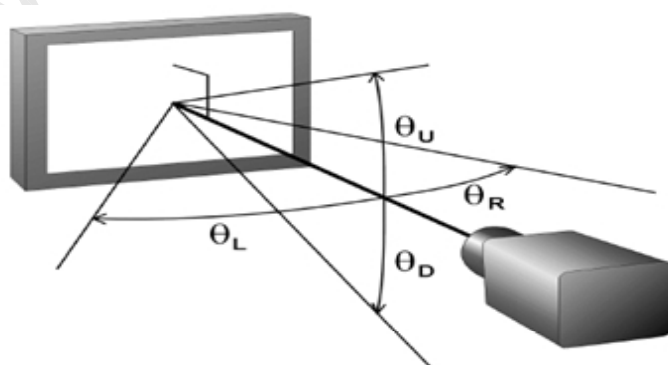

MODEL

LTA460HQ08

Doc. No

06-000-G-20100831

Page

8 / 27

Samsung Secret

3. Electrical Characteristics

3.1 TFT LCD Module

The connector for display data & timing signal should be connected.

$T_a = 25^\circ\text{C} \pm 2^\circ\text{C}$

Item	Symbol	Min.	Typ.	Max.	Unit	Note
Voltage of Power Supply	V_{DD}	10.8	12.0	13.2	V	(1)
Current of Power Supply	(a) Black	-	2400	2700	mA	(2),(3)
	(b) White	-	2350	2700	mA	
	(c) H-STRIPE	-	2700	3000	mA	
Vsync Frequency	f_V	-	60.0	-	Hz	
Hsync Frequency	f_H	-	67.5	-	kHz	
Main Frequency	f_{DCLK}	-	148.5	-	MHz	
Rush Current	I_{RUSH}	-	-	8	A	(4)

Note (1) The ripple voltage should be controlled under 10% of V_{DD} .

(2) $f_V=60\text{Hz}$, $f_{DCLK} = 148.5\text{MHz}$, $V_{DD} = 12.0\text{V}$, DC Current.

(3) Power dissipation check pattern (LCD Module only)

a) Black Pattern



b) White Pattern



c) H-STRIPE

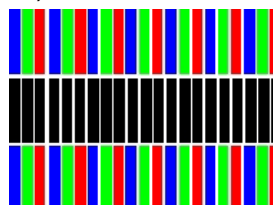

(4) Measurement Conditions

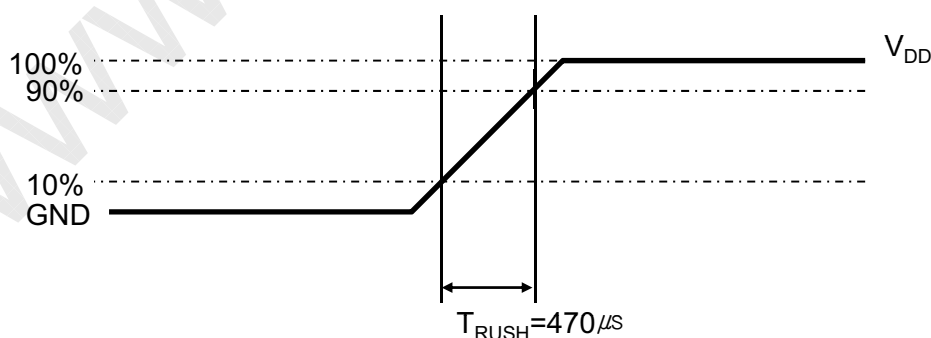

Rush Current I_{RUSH} can be measured when T_{RUSH} is $470 \mu\text{s}$.

MODEL

LTA460HQ08

Doc. No

06-000-G-20100831

Page

9 / 27

Samsung Secret

3.2 Back Light Unit

The back light unit contains Edge type White LEDs (Light Emitting Diode)

Ta=25 ± 2°C

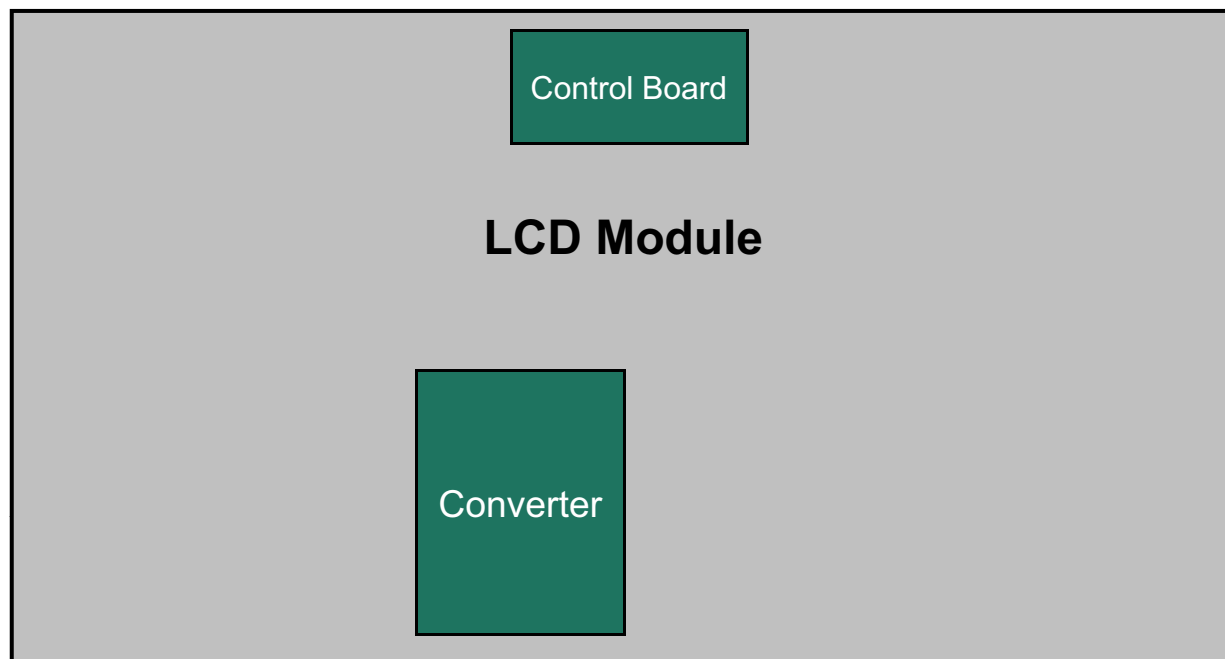

Item	Symbol	Min.	Typ.	Max.	Unit	Note
Operating Life Time	Hr	30,000	-	-	Hour	(1)

Note (1) It is defined as the time to take until the brightness reduces to 50% of its original value.

[Operating condition : Ta = 25±2°C, For single lamp only.]

MODEL	LTA460HQ08	Doc. No	06-000-G-20100831	Page	10 / 27
-------	------------	---------	-------------------	------	---------

3.3 Inverter Input Condition & Specification

Samsung Secret

Items	Symbol	Conditions	Specifications			Unit	Note
			Min.	Typ.	Max.		
Input Voltage	V _{in}	-	22	24	26	V	Ta=25±2 °C
Input Current	I _{RUSH}	V _{in} =24.0V V _{dim} =3.3V	-	-	10	A	
Output Current	I _{O (2D)}	V _{in} = 24.0V V _{dim} =3.3 V	90	95	100	mAmps	Note (1)
	I _{O (3D)}	3D ENA = ON	105	110	115		
Shut down Time	T _{sd}	V _{in} =22.0 ~26.0V V _{dim} : 0~3.3V	-	-	500	msec	
Backlight On/Off	ON	V _{in} =24.0 V	2.4	-	5.5	V	
	OFF	V _{in} =24.0 V	0	-	0.8		
Dimming Range	V _{DIM}	V _{in} :22~26V	0	-	3.3	V	Note(2)
Dimming Duty Output	D max	V _{in} =24V Dim:3.3V	100	-	-	%	
	D min	V _{in} =24V Dim:0V	-	0	-		
Dimming Frequency	F _{PWM}	V _{in} =24.0 V	260	270	280	Hz	
External Dimming Duty Range	EX_Dim	V _{in} =22.0~26.0 V Dim Pin(#13):floating	0	-	100	%	
External Dimming Frequency Range	F _{EX_PWM}		95	-	300	Hz	
External Dimming Signal Level	V _{PWM}	High (ON)	2.4	-	5.5	V	
		Low (Off)	0	-	0.8		

Note (1) All data is measured after 120min warm-up.

Note (2) V_{Dim} and Ex_Dim are available only at Normal 2D mode. (3D ENA = OFF)

Note (3) Duty = On / (On+Off) * 100

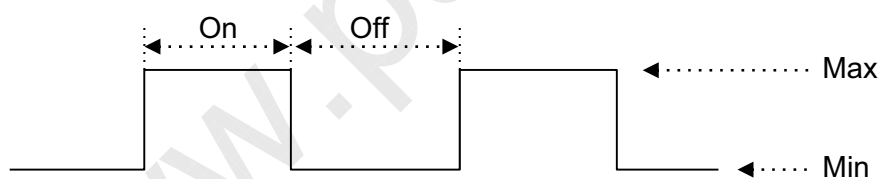

- Additional Appendix for Supply Current (Only for Reference_2D mode)

Items	Symbol	Conditions	Min.	Typ.	Max.	Unit
Input Current	I _{in_saturation}	V _{in} = 24V, Dim=3.3V (After 1hr Aging)	-	4.5	4.7	A
Power Consumption (Back light)	P _{_Inrush}	V _{in} =24.0V, V _{dim} = 3.3V	-	-	240	Watt
	P _{_saturation}	V _{in} = 24V, Dim=3.3V (After 1hr Aging)	-	108	113	Watt

MODEL

LTA460HQ08

Doc. No

06-000-G-20100831

Page

11 / 27

4. Input Terminal Pin Assignment

Samsung Secret

4.1. Input Signal & Power

Connector : FI-RE51S-HF (JAE)

Pin	Symbol	Description	Pin	Symbol	Description
1	12V	DC power supply	26	RE[0]P	Even LVDS Signal +
2	12V	DC power supply	27	RE[1]N	Even LVDS Signal -
3	12V	DC power supply	28	RE[1]P	Even LVDS Signal +
4	12V	DC power supply	29	RE[2]N	Even LVDS Signal -
5	12V	DC power supply	30	RE[2]P	Even LVDS Signal +
6	NC	NOTE1	31	GND	Ground
7	GND	Ground	32	ROCLK-	Even LVDS Clock -
8	GND	Ground	33	ROCLK+	Even LVDS Clock +
9	GND	Ground	34	GND	Ground
10	RO[0]N	Odd LVDS Signal -	35	RE[3]N	Even LVDS Signal -
11	RO[0]P	Odd LVDS Signal +	36	RE[3]P	Even LVDS Signal +
12	RO[1]N	Odd LVDS Signal -	37	RE[4]N	Even LVDS Signal -
13	RO[1]P	Odd LVDS Signal +	38	RE[4]P	Even LVDS Signal +
14	RO[2]N	Odd LVDS Signal -	39	GND	Ground
15	RO[2]P	Odd LVDS Signal +	40	NC	NOTE1
16	GND	Ground	41	NC	NOTE1
17	ROCLK-	Odd LVDS Clock -	42	3D Enable	Low : 2D High : 3D (Note 2,3)
18	ROCLK+	Odd LVDS Clock +	43	NC	NOTE1
19	GND	Ground	44	NC	NOTE1
20	RO[3]N	Odd LVDS Signal -	45	NC	NOTE1
21	RO[3]P	Odd LVDS Signal +	46	I2C_SCL_F	Set use pin (Note 3)
22	RO[4]N	Odd LVDS Signal -	47	NC	NOTE1
23	RO[4]P	Odd LVDS Signal +	48	I2C_SDA_F	Set use pin (Note 3)
24	GND	Ground	49	3D Sync	Shutter glass sync signal
25	RE[0]N	Even LVDS Signal -	50	Main check	GND (Note 3)
			51	NC	NOTE1

Note (1) No Connection: These PINS are used only for SAMSUNG. (DO NOT CONNECT)

Note (2) 3D Enable signal voltage level

High : Min 2.4V, Max 5.25V Low : Min 0 V, Max 0.8V

MODEL

LTA460HQ08

Doc. No

06-000-G-20100831

Page

12 / 27

Samsung Secret

Note (3) MAIN_CHECK (I2C communication should be started after a certain time from Vin(12V))
 -. LOW (GND) → AUTO SCRIPT Disable mode (I2C communicates after 6.00 sec from Vin)
 → (In this case, customer can control FRC chip)

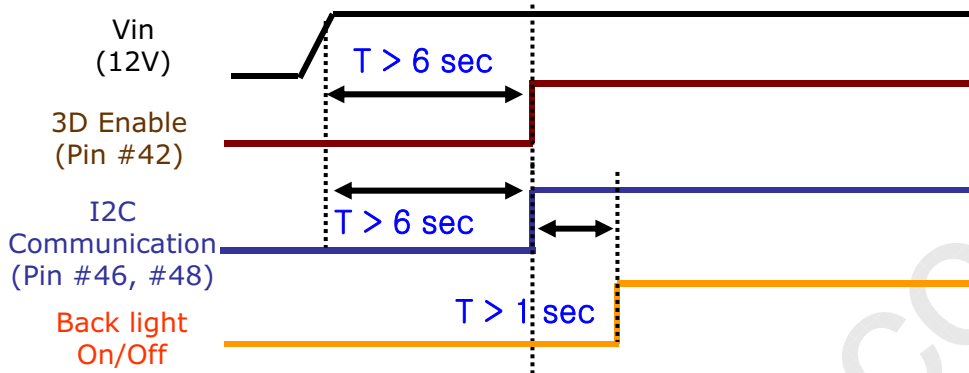

[Timing Sequence for I2C communication]

Note (4) Pin number starts from Left side

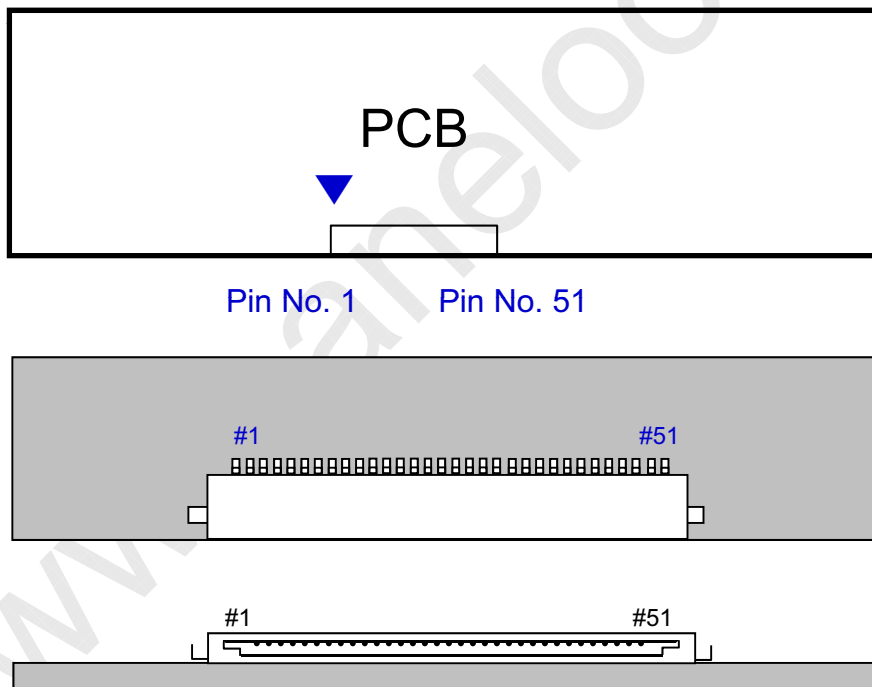

Fig. Connector diagram

- a. Power GND pins should be connected to the LCD's metal chassis.
- b. All power input pins should be connected together.
- c. All NC pin should be separated from other signal or power.

MODEL	LTA460HQ08	Doc. No	06-000-G-20100831	Page	13 / 27
-------	------------	---------	-------------------	------	---------

4.2. Converter Input Pin Configuration

Samsung Secret

Connector : Yeon-ho, 20022WR-14B1

Pin No.	Pin Configuration(FUNCTION)
	Master
1	24 V
2	24 V
3	24 V
4	24 V
5	24 V
6	GND
7	GND
8	GND
9	GND
10	GND
11	Error Out
12	Backlight On /Off [ON:2.4 – 5.5 V, OFF: 0 - 0.8 V]
13	Dimming Control [0V:Min, 3.3V:Max] *Note(1)
14	External PWM [0~100%] *Note(1)

Note(1) If use Dimming Control, Pin 14 Must be N.C

If use External PWM, Pin 13 Must be N.C

4.3. Converter Input Power Sequence

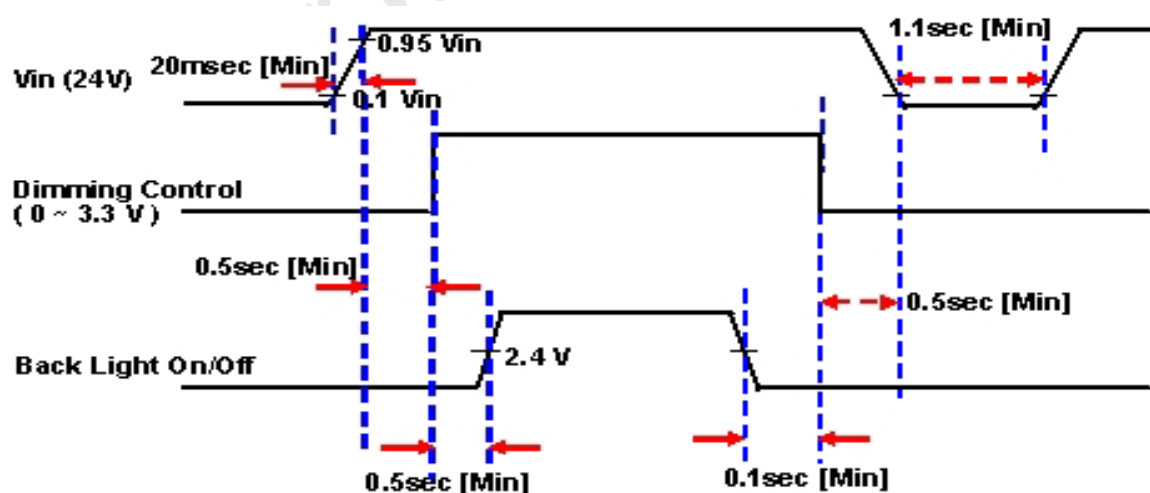

Note) SEQUENCE : ON = Vin(24V) > Dimming Control ≥ Backlight On/Off

OFF = Backlight On/Off ≥ Dimming Control > Vin(24V)

4.4 LVDS Interface

Samsung Secret

- LVDS Receiver : Tcon (merged)
- Data Format (JEIDA & Normal)

	LVDS pin	JEIDA -DATA	Normal -DATA
TxOUT/RxIN0	TxIN/RxOUT0	R4	R0
	TxIN/RxOUT1	R5	R1
	TxIN/RxOUT2	R6	R2
	TxIN/RxOUT3	R7	R3
	TxIN/RxOUT4	R8	R4
	TxIN/RxOUT6	R9	R5
	TxIN/RxOUT7	G4	G0
TxOUT/RxIN1	TxIN/RxOUT8	G5	G1
	TxIN/RxOUT9	G6	G2
	TxIN/RxOUT12	G7	G3
	TxIN/RxOUT13	G8	G4
	TxIN/RxOUT14	G9	G5
	TxIN/RxOUT15	B4	B0
	TxIN/RxOUT18	B5	B1
TxOUT/RxIN2	TxIN/RxOUT19	B6	B2
	TxIN/RxOUT20	B7	B3
	TxIN/RxOUT21	B8	B4
	TxIN/RxOUT22	B9	B5
	TxIN/RxOUT24	HSYNC	HSYNC
	TxIN/RxOUT25	VSYNC	VSYNC
	TxIN/RxOUT26	DEN	DEN
TxOUT/RxIN3	TxIN/RxOUT27	R2	R6
	TxIN/RxOUT5	R3	R7
	TxIN/RxOUT10	G2	G6
	TxIN/RxOUT11	G3	G7
	TxIN/RxOUT16	B2	B6
	TxIN/RxOUT17	B3	B7
	TxIN/RxOUT23	RESERVED	RESERVED
TxOUT/RxIN4	TxIN/RxOUT28	R0	R8
	TxIN/RxOUT29	R1	R9
	TxIN/RxOUT30	G0	G8
	TxIN/RxOUT31	G1	G9
	TxIN/RxOUT32	B0	B8
	TxIN/RxOUT33	B1	B9
	TxIN/RxOUT34	RESERVED	RESERVED

MODEL

LTA460HQ08

Doc. No

06-000-G-20100831

Page

15 / 27

Samsung Secret

4.5 Input Signals, Basic Display Colors and Gray Scale of Each Color

COLOR	DISPLAY (8bit)	DATA SIGNAL																												GRAY SCALE LEVEL	
		RED									GREEN									BLUE											
		R0	R1	R2	R3	R4	R5	R6	R7	R8	R9	G0	G1	G2	G3	G4	G5	G6	G7	G8	G9	B0	B1	B2	B3	B4	B5	B6	B7		B8
BASIC COLOR	BLACK	0	0	0	0	0	0	0	0	0	0	0	0	0	0	0	0	0	0	0	0	0	0	0	0	0	0	0	0	-	
	BLUE	0	0	0	0	0	0	0	0	0	0	0	0	0	0	0	0	0	0	0	0	1	1	1	1	1	1	1	1	1	-
	GREEN	0	0	0	0	0	0	0	0	0	0	1	1	1	1	1	1	1	1	1	1	0	0	0	0	0	0	0	0	0	-
	CYAN	0	0	0	0	0	0	0	0	0	0	1	1	1	1	1	1	1	1	1	1	1	1	1	1	1	1	1	1	1	-
	RED	1	1	1	1	1	1	1	1	1	1	0	0	0	0	0	0	0	0	0	0	0	0	0	0	0	0	0	0	0	-
	MAGENTA	1	1	1	1	1	1	1	1	1	1	0	0	0	0	0	0	0	0	0	0	1	1	1	1	1	1	1	1	1	-
	YELLOW	1	1	1	1	1	1	1	1	1	1	1	1	1	1	1	1	1	1	1	1	0	0	0	0	0	0	0	0	0	-
	WHITE	1	1	1	1	1	1	1	1	1	1	1	1	1	1	1	1	1	1	1	1	1	1	1	1	1	1	1	1	1	-
GRAY SCALE OF RED	BLACK	0	0	0	0	0	0	0	0	0	0	0	0	0	0	0	0	0	0	0	0	0	0	0	0	0	0	0	0	R0	
	DARK ↑	1	0	0	0	0	0	0	0	0	0	0	0	0	0	0	0	0	0	0	0	0	0	0	0	0	0	0	0	R1	
		0	1	0	0	0	0	0	0	0	0	0	0	0	0	0	0	0	0	0	0	0	0	0	0	0	0	0	0	R2	
		:	:	:	:	:	:	:	:	:	:	:	:	:	:	:	:	:	:	:	:	:	:	:	:	:	:	:	:	:	R3~R1020
	LIGHT ↓	:	:	:	:	:	:	:	:	:	:	:	:	:	:	:	:	:	:	:	:	:	:	:	:	:	:	:	:	:	
		1	0	1	1	1	1	1	1	1	1	0	0	0	0	0	0	0	0	0	0	0	0	0	0	0	0	0	0	R1021	
		0	1	1	1	1	1	1	1	1	1	0	0	0	0	0	0	0	0	0	0	0	0	0	0	0	0	0	0	R1022	
RED	1	1	1	1	1	1	1	1	1	1	0	0	0	0	0	0	0	0	0	0	0	0	0	0	0	0	0	0	R1023		
GRAY SCALE OF GREEN	BLACK	0	0	0	0	0	0	0	0	0	0	0	0	0	0	0	0	0	0	0	0	0	0	0	0	0	0	0	0	G0	
	DARK ↑	0	0	0	0	0	0	0	0	0	0	1	0	0	0	0	0	0	0	0	0	0	0	0	0	0	0	0	0	G1	
		0	0	0	0	0	0	0	0	0	0	0	1	0	0	0	0	0	0	0	0	0	0	0	0	0	0	0	0	G2	
		:	:	:	:	:	:	:	:	:	:	:	:	:	:	:	:	:	:	:	:	:	:	:	:	:	:	:	:	G3~G1020	
	LIGHT ↓	:	:	:	:	:	:	:	:	:	:	:	:	:	:	:	:	:	:	:	:	:	:	:	:	:	:	:	:		
		0	0	0	0	0	0	0	0	0	0	1	0	1	1	1	1	1	1	1	1	0	0	0	0	0	0	0	0	G1021	
		0	0	0	0	0	0	0	0	0	0	1	1	1	1	1	1	1	1	1	1	0	0	0	0	0	0	0	0	G1022	
GREEN	0	0	0	0	0	0	0	0	0	0	1	1	1	1	1	1	1	1	1	1	0	0	0	0	0	0	0	0	G1023		
GRAY SCALE OF BLUE	BLACK	0	0	0	0	0	0	0	0	0	0	0	0	0	0	0	0	0	0	0	0	0	0	0	0	0	0	0	0	B0	
	DARK ↑	0	0	0	0	0	0	0	0	0	0	0	0	0	0	0	0	0	0	0	0	1	0	0	0	0	0	0	0	B1	
		0	0	0	0	0	0	0	0	0	0	0	0	0	0	0	0	0	0	0	0	1	0	0	0	0	0	0	0	B2	
		:	:	:	:	:	:	:	:	:	:	:	:	:	:	:	:	:	:	:	:	:	:	:	:	:	:	:	:	B3~B1020	
	LIGHT ↓	:	:	:	:	:	:	:	:	:	:	:	:	:	:	:	:	:	:	:	:	:	:	:	:	:	:	:	:		
		0	0	0	0	0	0	0	0	0	0	0	0	0	0	0	0	0	0	0	0	1	0	1	1	1	1	1	1	B1021	
		0	0	0	0	0	0	0	0	0	0	0	0	0	0	0	0	0	0	0	0	1	1	1	1	1	1	1	1	B1022	
BLUE	0	0	0	0	0	0	0	0	0	0	0	0	0	0	0	0	0	0	0	0	1	1	1	1	1	1	1	1	B1023		

Note) Definition of Gray :

Rn : Red Gray, Gn : Green Gray, Bn : Blue Gray (n = Gray level)

Input Signal : 0 = Low level voltage, 1 = High level voltage

MODEL	LTA460HQ08	Doc. No	06-000-G-20100831	Page	16 / 27
-------	------------	---------	-------------------	------	---------

Samsung Secret

5. Interface Timing

5.1 Timing Parameters (DE mode)

SIGNAL	ITEM	SYMBOL	Video	PAL	NTSC	Unit	NOTE
Clock	Frequency	$1/T_C$	142.56	148.5	148.5	MHz	-
Hsync		F_H	64.8	67.5	67.5	KHz	-
Vsync		F_V	48	50	60	Hz	(3)
Vertical Display Term	Active Display Period	T_{VD}	1080	1080	1080	Lines	-
	Vertical Total	T_V	1350	1350	1125	Lines	-
Horizontal Display Term	Active Display Period	T_{HD}	1920	1920	1920	Clocks	-
	Horizontal Total	T_H	2200	2200	2200	clocks	-

Note) This product is DE mode. But the Hsync & Vsync signal must be inputted

- (1) Test Point : TTL control signal and CLK at LVDS Tx input terminal in system
- (2) Internal VDD = 3.3V
- (3) Vsync polarity must be negative (Hsync polarity – don't care)
- (4) Spread spectrum
 - Modulation rate (max) : $\pm 2.8\%$ (Set + FRC chip)
 - Modulation Frequency : under 62.5 KHz

5.2 LVDS Input Data Characteristics

ITEM		SYMBOL	Min.	Typ.	Max.	UNIT	NOTE
Input Data Position	$F_{IN}=74.25$ MHz	t_{RSRM}	-	-	220	ps	
		t_{RSLM}	-220	-	-	ps	
Input common mode voltage		V_{CM}	0.6	1.2	1.6	V	-
Differential Input Voltage		$ V_{ID} $	60	200	500	mV	-

Note) When the skew is measured the Spread Spectrum should be 0%

MODEL

LTA460HQ08

Doc. No

06-000-G-20100831

Page

17 / 27

5.3 Timing diagrams of interface signal (DE mode)

Samsung Secret

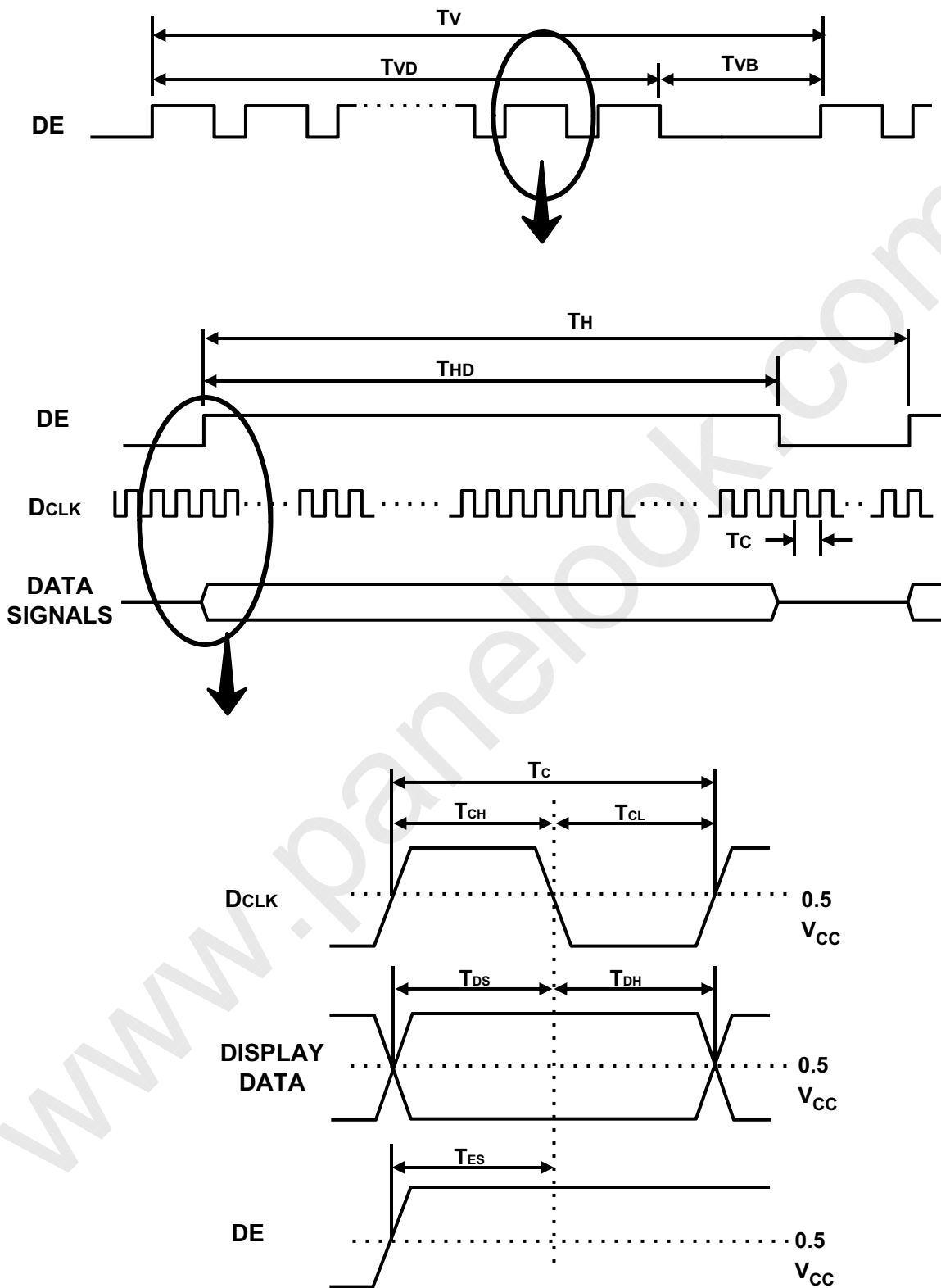

MODEL	LTA460HQ08	Doc. No	06-000-G-20100831	Page	18 / 27
-------	------------	---------	-------------------	------	---------

5.4 Power ON/OFF Sequence

Samsung Secret

To prevent a latch-up or DC operation of the LCD Module, the power on/off sequence should be as the diagram below.

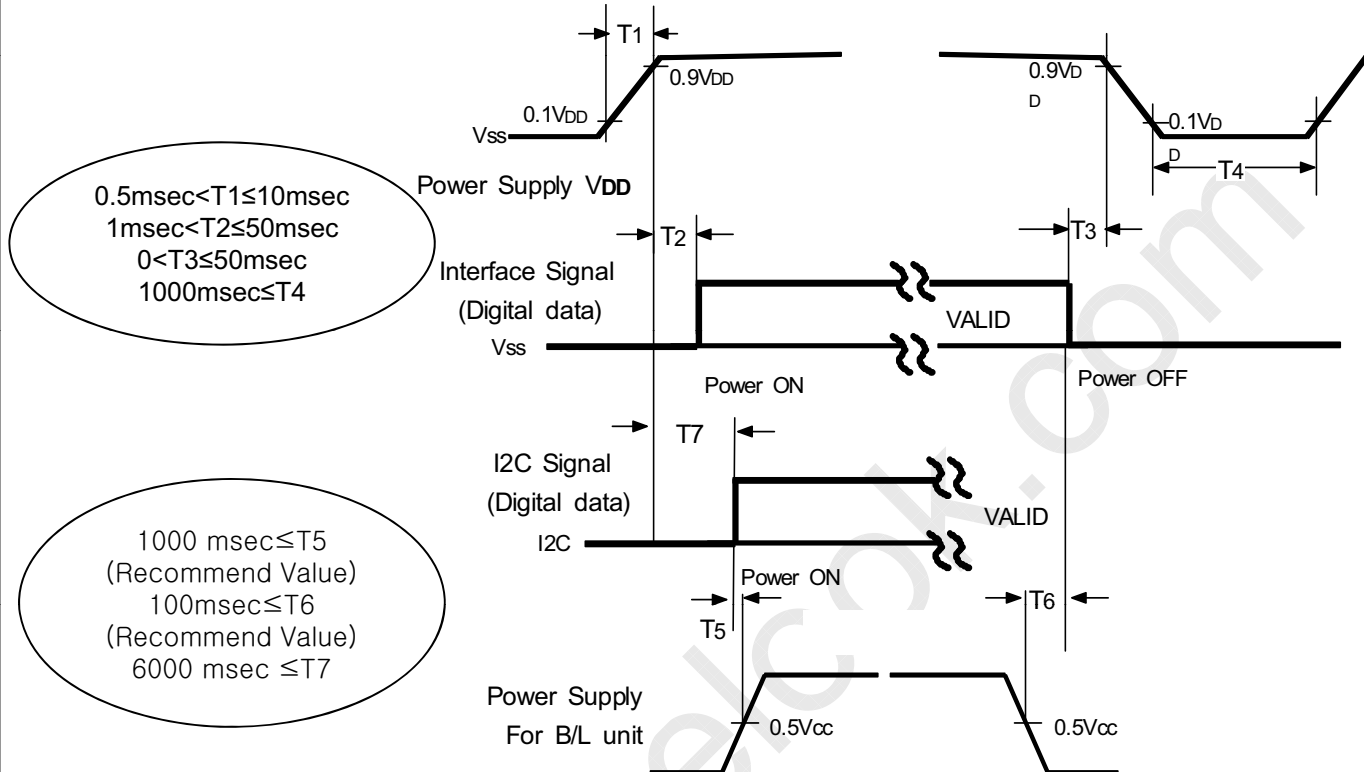

T1 : V_{DD} rising time from 10% to 90%

T2 : The time from V_{DD} to valid data at power ON.

T3 : The time from valid data off to V_{DD} off at power Off.

T4 : V_{DD} off time for Windows restart

T5 : The time from valid I2C Signal to B/L enable at power ON.

T6 : The time from valid data off to B/L disable at power Off.

T7 : The time from V_{DD} to valid I2C Signal to control FRC.

- The supply voltage of the external system for the Module input should be the same as the definition of V_{DD} .
- Apply the lamp voltage within the LCD operation range. When the back light turns on before the LCD operation or the LCD turns off before the back light turns off, the display may momentarily show abnormal screen.
- In case of V_{DD} = off level, please keep the level of input signals low or keep a high impedance.
- T4 should be measured after the Module has been fully discharged between power off and on period.
- Interface signal should not be kept at high impedance when the power is on.
- In Case T5 is less than 1000msec and T6 is less than 100msec, Garbage Display can be seen. (It is not related to electrical function issue, Just for recommendation to prevent Garbage Display)

7. Outline Dimension (Front View)

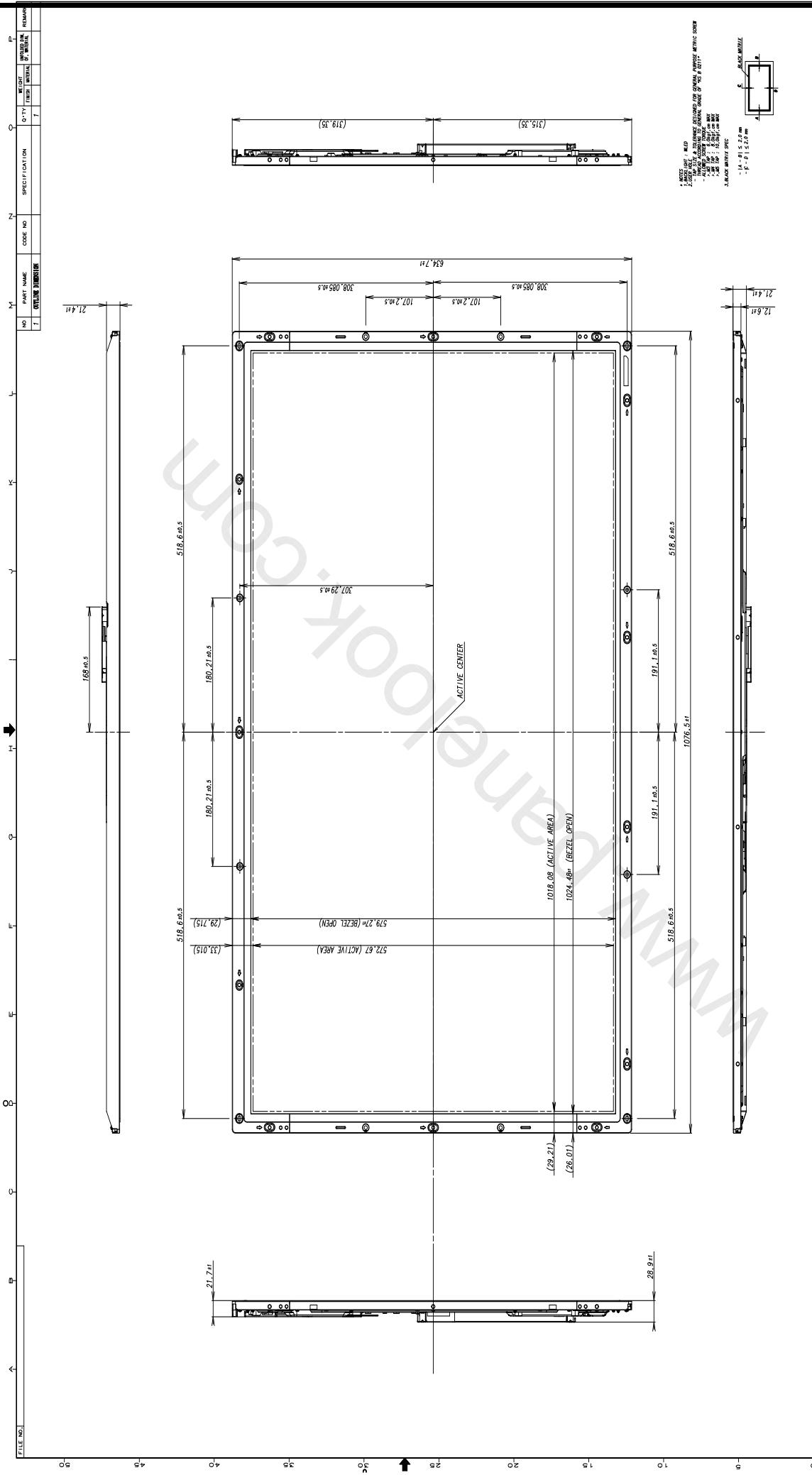

1. UNITS: DIMENSIONS ARE IN MILLIMETERS UNLESS OTHERWISE SPECIFIED.
 2. DIMENSIONS ARE TO THE CENTER OF THE HOLE UNLESS OTHERWISE SPECIFIED.
 3. DIMENSIONS ARE TO THE CENTER OF THE HOLE UNLESS OTHERWISE SPECIFIED.
 4. DIMENSIONS ARE TO THE CENTER OF THE HOLE UNLESS OTHERWISE SPECIFIED.
 5. DIMENSIONS ARE TO THE CENTER OF THE HOLE UNLESS OTHERWISE SPECIFIED.
 6. DIMENSIONS ARE TO THE CENTER OF THE HOLE UNLESS OTHERWISE SPECIFIED.
 7. DIMENSIONS ARE TO THE CENTER OF THE HOLE UNLESS OTHERWISE SPECIFIED.
 8. DIMENSIONS ARE TO THE CENTER OF THE HOLE UNLESS OTHERWISE SPECIFIED.
 9. DIMENSIONS ARE TO THE CENTER OF THE HOLE UNLESS OTHERWISE SPECIFIED.
 10. DIMENSIONS ARE TO THE CENTER OF THE HOLE UNLESS OTHERWISE SPECIFIED.

STEP	LEVEL 1	LEVEL 2	LEVEL 3	UNIT	REVISION	DATE	BY	CHK'D BY	APP'D BY	REASON
0	X x 4	±0.05	±0.1	±0.2	SCALE	N/A	1:1			INITIAL DIMENSION
4	X x 16	±0.08	±0.15	±0.3	TOLERANCE	1/2000				
16	X x 64	±0.12	±0.25	±0.5						
64	X x 256	±0.25	±0.4	±0.8						

FILE NO.	PART NAME	CODE NO.	SPECIFICATION	QTY	WEIGHT	REMARK
	LTA460HQ08			7		

MODEL NAME	MODEL NO.	PAPER/SHEET	CODE NO.
LTA460HQ08	1774607908	1/1	

GENERAL TOLERANCE	LEVEL 1	LEVEL 2	LEVEL 3
STEP	0	4	16
TOLERANCE	±0.05	±0.1	±0.2
SCALE	1:1	1:1	1:1
DATE			
BY			
CHK'D BY			
APP'D BY			
REVISION			
DATE			
BY			
CHK'D BY			
APP'D BY			

7. Outline Dimension (Rear View)

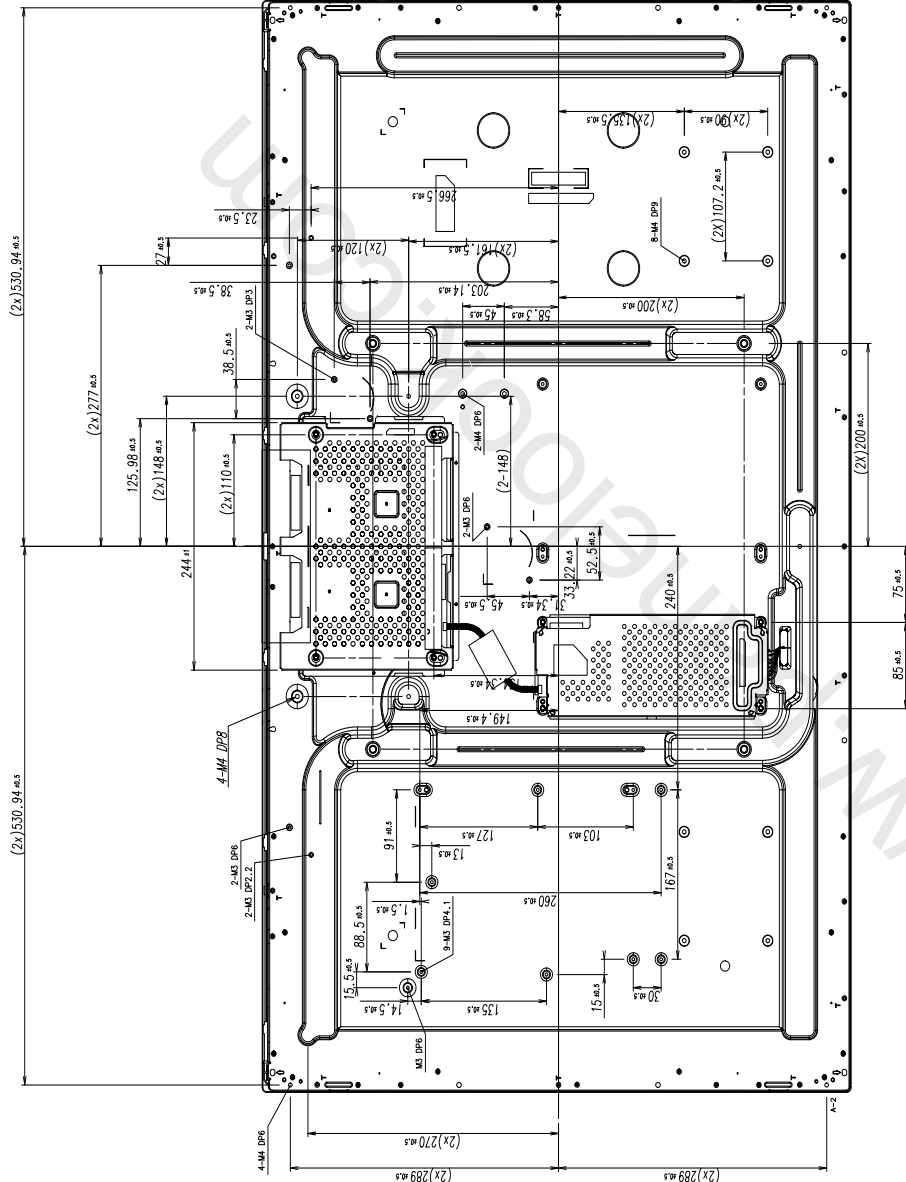

NO.	PART NAME	CODE NO.	SPECIFICATION	Q'TY	WEIGHT	REMARK
T	OUTLINE DIMENSION			T		

GENERAL TOLERANCE			DESCRIPTION OF REVISION				REASON			
STEP	LEVEL	UNIT	NO.	DATE	BY	CHK'D BY	APP'D BY	MODEL NAME	PANELLET	SHEET
0 < X < 4	±0.05	mm	±0.1					LTA460HQ08	OUTLINE DIMENSION	2/2
4 < X < 16	±0.08	mm	±0.15							
16 < X < 64	±0.12	mm	±0.25							
64 < X < 256	±0.25	mm	±0.4							

Samsung Secret

7. Reliability Test

Item	Test condition	Quantity
Temperature Step Stress	-20 ~ 60℃, 40hr, 5 Cycle determination	4EA
HTOL	50℃, 500hr determination	4EA
LTOL	-5℃, 500hr determination	4EA
HTS	70℃, 500hr determination	4EA
LTS	-25℃, 500hr determination	4EA
THB	50℃ / 80%RH, 500hr determination	4EA
WHTS	60℃ / 75%RH, 250hr determination	4EA
Thermal Shock	-20℃ ~ 60℃, 100cycle determination	4EA
ESD (operation)	contact : ± 10kV, 150pF/330Ω, 210Point, 1 time/Point non-contact : ± 20 kV, 150pF/330Ω, 210Point, 1 time/Point	3EA
Converter Input Con. ESD	contact : ± 15kV, 150pF/330, Input Con.Pin, 3 times/Pin	3EA
Vibration	10~300Hz/1.5G/10minSR, XYZ, 30min/axis	3EA
Shock	Half Sine, 11msec, ±X,Y,Z 50G 1time/axis	3EA
PALLET Vibration	1.05Grms 5~200Hz 1hr	1PALLET(16EA)
PALLET Drop	4 edge 1face(bottom) 20 cm	1PALLET(16EA)

[Result Evaluation Criteria]

Under the display quality test conditions with normal operation state, these should be no change which may affect practical display functions.

- * HTOL/ LTOL : High/Low Temperature Operating Life
- ** THB : Temperature Humidity Bias
- *** HTS/LTS : High/Low Temperature Storage
- **** WHTS : Wet High Temperature Storage

MODEL

LTA460HQ08

Doc. No

06-000-G-20100831

Page

22 / 27

Samsung Secret

8. PACKING

8.1 CARTON (Internal Package)

(1) Packing Form

Corrugated fiberboard box and corrugated cardboard as shock absorber

(2) Packing Method

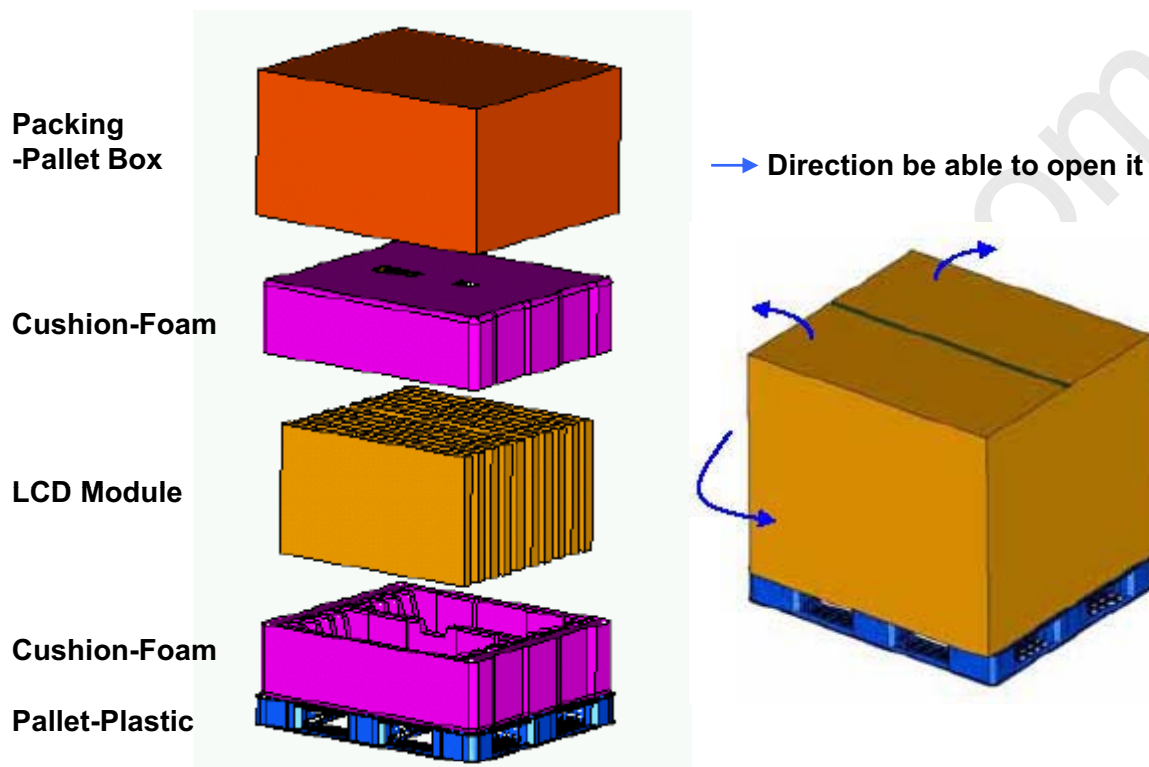

8.2 Packing Specification

Item	Specification	Remark
LCD Packing	16 ea / (Packing-Pallet Box)	1. 184 kg / LCD (16ea) 2. 7 Kg / Cushion-pallet (2ea) 3. 6.7 Kg / Packing-Pallet Box (1ea) 4. Cushion-pallet Material : EPS 5. Packing-Pallet Box Material : SW4
Pallet	1Box / Pallet	1. Pallet weight = 8kg
Packing Direction	Vertical	
Total Pallet Size	H x V x height	1150 mm(H) x 985 mm(V) x 609 mm(height)
Total Pallet Weight	205.7 kg	Pallet(8 kg) + Module (184 kg) + Cushion (up + bottom =7kg) + Pallet-BOX(6.7 kg)

MODEL

LTA460HQ08

Doc. No

06-000-G-20100831

Page

23 / 27

Samsung Secret

9. MARKING & OTHERS

A nameplate bearing followed by is affixed to a shipped product at the specified location on each product.

- (1) Part number : LTA460HQ08
- (2) Revision: Three letters
- (3) Lot number : X X X X XXX XX X

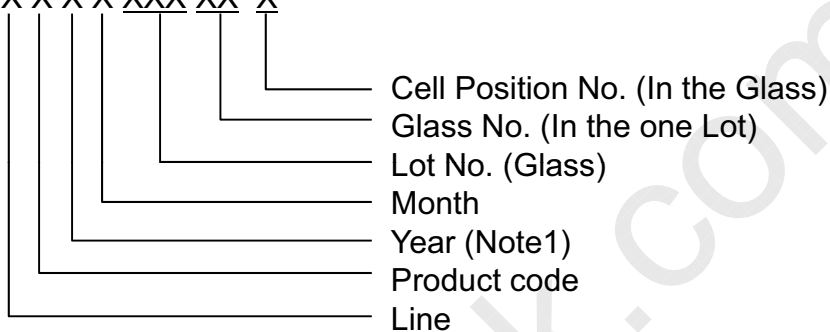

(4) Nameplate Indication

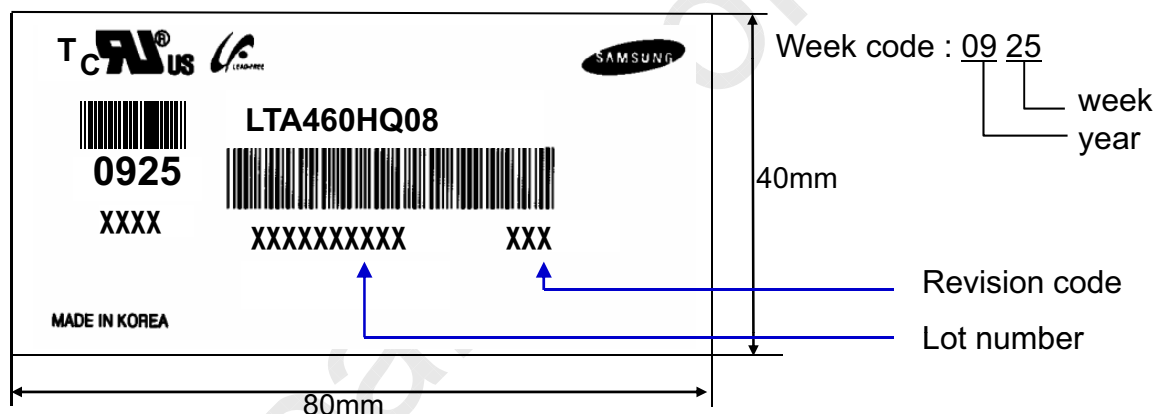

(5) Packing box attach

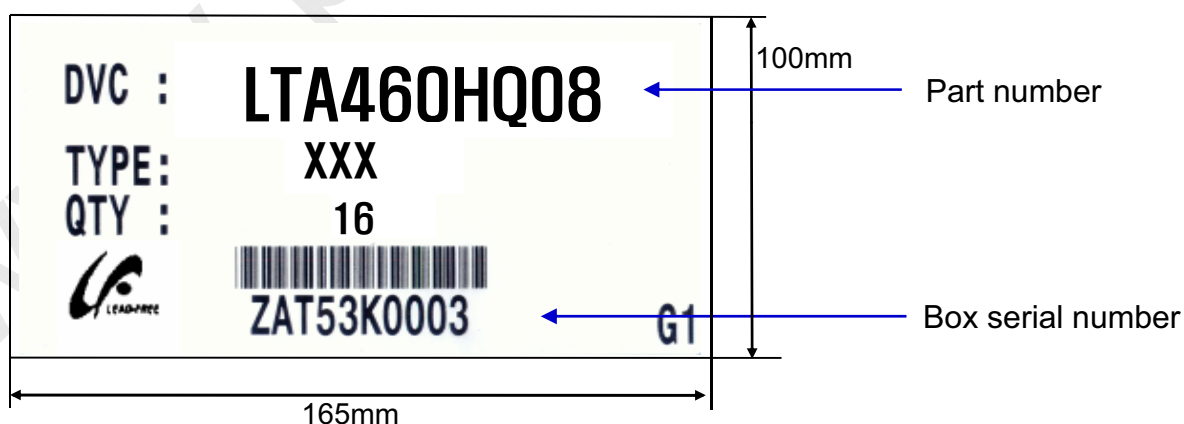

(6) Others

- 1. After service part
 Lamps cannot be replaced because of the narrow bezel structure.

MODEL	LTA460HQ08	Doc. No	06-000-G-20100831	Page	24 / 27
-------	------------	---------	-------------------	------	---------

10. General Precautions

Samsung Secret

10.1 Handling

- (a) When the Module is assembled, it should be attached to the system firmly using all mounting holes. Be careful not to twist and bend the Module.
- (b) Because the inverter use high voltage, it should be disconnected from power before it is assembled or disassembled.
- (c) Refrain from strong mechanical shock and / or any force to the Module.
In addition to damage, this may cause improper operation or damage to the Module and LED back light.
- (d) Note that polarizers are very fragile and could be damage easily.
Do not press or scratch the surface harder than a HB pencil lead.
- (e) Wipe off water droplets or oil immediately. If you leave the droplets for a long time, staining or discoloration may occur.
- (f) If the surface of the polarizer is dirty, clean it using absorbent cotton or soft cloth.
- (g) Desirable cleaners are water, IPA(Isopropyl Alcohol) or Hexane.
Do not use Ketone type materials(ex. Acetone), Ethyl alcohol, Toluene, Ethyl acid or Methyl chloride. It might permanent damage to the polarizer due to chemical reaction.
- (h) If the liquid crystal material leaks from the panel, it should be kept away from the eyes or mouth . In case of contact with hands, legs or clothes, it must be washed away with soap thoroughly.
- (i) Protect the module from Electrostatic discharge. Otherwise the ASIC IC or semiconductor would be damaged.
- (j) Use finger-stalls with soft gloves in order to keep display clean during the incoming inspection and assembly process.
- (k) Do not disassemble the Module.
- (l) Do not disassemble shield case of inverter & LVDS board
- (m) Do not connect N.C pins. (Samsung internal use only)
- (n) Protection film for polarizer on the Module should be slowly peeled off just before use so that the electrostatic charge can be minimized. Must put on antistatic glove while handling a module
- (o) Pins of I/F connector should not be touched directly with bare hands.

MODEL

LTA460HQ08

Doc. No

06-000-G-20100831

Page

25 / 27

Samsung Secret

10.2 Storage

- (a) Do not leave the Module in high temperature, and high humidity for a long time. It is highly recommended to store the Module with temperature from 0 to 35°C and relative humidity of less than 70%.
- (b) Do not store the TFT-LCD Module in direct sunlight.
- (c) The Module should be stored in a dark place. It is prohibited to apply sunlight or fluorescent light in storing.

10.3 Operation

- (a) Do not connect or disconnect the Module in the "Power On" condition.
- (b) Power supply should always be turned on/off by the "Power on/off sequence"
- (c) Module has high frequency circuits. Sufficient suppression to the electromagnetic interference should be done by system manufacturers. Grounding and shielding methods may be important to minimize the interference.
- (d) The cable between the back light connector and its inverter power supply should be connected directly with a minimized length. A longer cable between the back light and the inverter may cause lower luminance of lamp(LED) and may require higher startup voltage(Vs).

10.4 Operation Condition Guide

- (a) The LCD product should be operated under normal conditions.
Normal condition is defined as below;
 - Temperature : $20 \pm 15^{\circ}\text{C}$
 - Humidity : $55 \pm 20\%$
 - Display pattern : continually changing pattern (Not stationary)
- (b) If the product will be used in extreme conditions such as high temperature, humidity, display patterns or operation time etc., It is strongly recommended to contact SEC for Application engineering advice. Otherwise, its reliability and function may not be guaranteed. Extreme conditions are commonly found at Airports, Transit Stations, Banks, Stock market, and Controlling systems.

MODEL

LTA460HQ08

Doc. No

06-000-G-20100831

Page

26 / 27

10.5 Others

Samsung Secret

- (a) Ultra-violet ray filter is necessary for outdoor operation.
- (b) Avoid condensation of water. It may result in improper operation or disconnection of electrode.
- (c) Do not exceed the absolute maximum rating value. (supply voltage variation, input voltage variation, variation in part contents and environmental temperature, and so on)
Otherwise the Module may be damaged.
- (d) If the Module keeps displaying the same pattern for a long period of time, the image may be "sticked" to the screen.
To avoid image sticking, it is recommended to use a screen saver.
- (e) This Module has its circuitry PCB's on the rear side and should be handled carefully in order not to be stressed.
- (f) Please contact SEC in advance when you display the same pattern for a long time.

MODEL

LTA460HQ08

Doc. No

06-000-G-20100831

Page

27 / 27