



## Product Information

**Customer : THTF****DATE : 21. July. 2011****SAMSUNG TFT-LCD****MODEL : LTA460HQ12-C03**

The Information Described in this Specification is Preliminary and can be changed without prior notice

LCD Business

Samsung Electronics Co . , LTD.

MODEL	LTA460HQ12-C03	Doc. No	06-000-G-20110721	Page	1 / 28
-------	----------------	---------	-------------------	------	--------

## Contents

Revision History -----	(3)
General Description -----	(4)
General Information -----	(4)
1. Absolute Maximum Ratings -----	(5)
2. Optical Characteristics -----	(6)
3. Electrical Characteristics -----	(9)
3.1 TFT LCD Module	
3.2 Back Light Unit	
3.3 converter Input & Specification	
4. Input Terminal Pin Assignment -----	(12)
4.1 Input Signal & Power	
4.2 Converter Input Pin Configuration	
4.3 Converter Input Power Sequence	
4.4 LVDS Interface	
4.5 Input Signals, Basic Display Colors and Gray Scale of Each Color	
5. Interface Timing -----	(18)
5.1 Timing Parameters (DE only mode)	
5.2 LVDS Input data Characteristics	
5.3 3D mode Sequence	
5.4 Timing Diagrams of interface Signal (DE only mode)	
5.5 Power ON/OFF Sequence	
6. Outline Dimension -----	(22)
7. Packing -----	(24)
8. Marking & Others -----	(25)
9. General Precaution -----	(26)
9.1 Handling	
9.2 Storage	
9.3 Operation	
9.4 Operation Condition Guide	
9.5 Others	

**MODEL****LTA460HQ12-C03****Doc. No****06-000-G-20110721****Page****2 / 28**

## Revision History

Date	Rev. No	Page	Summary
21.July. 2011	000	all	First issued

**MODEL**

LTA460HQ12-C03

**Doc. No**

06-000-G-20110721

**Page**

3 / 28

## General Description

### Description

**LTA460HQ12-C03** is a color active matrix liquid crystal display (LCD) that uses amorphous silicon TFT(Thin Film Transistor) as switching components. This model is composed of a TFT LCD panel, a driver circuit and a back light unit. The resolution of a 46.0" is 1920 x 1080 and this model can display up to 1.07 Billion colors with wide viewing angle of 89° or higher in all directions. This panel is intended to support applications to provide a excellent performance for Flat Panel Display such as Home-alone Multimedia TFT-LCD TV and High Definition TV

### Features

- RoHS compliance (Pb-free)
- High contrast ratio & aperture ratio with wide color gamut
- SPVA(Super Patterned Vertical Align) mode
- Wide viewing angle ( $\pm 178^\circ$ )
- High speed response ( & Natural Motion (DFR: Double Frame Rate) )
- FHD resolution (16:9)
- Low Power consumption
- Edge Type LED (Light Emitted Diode) BLU
- DE (Data Enable) mode
- 4ch LVDS (Low Voltage Differential Signaling) interface (4pixel/clock)

### General Information

Items	Specification	Unit	Note
Module Size	1056.5 (W) X 610.8 (V)	mm	$\pm 1.0\text{mm}$
	31.4 (D)		
Weight	11800 (Max)	g	
Pixel Pitch	0.530(H) x 0.530(W)	mm	
Active Display Area	1018.08(H) X 572.67(V)	mm	
Surface Treatment	Antiglare, Hard-coating(3H)		
Display Colors	10 bit – 1.07 Billion	colors	
Number of Pixels	1920 x 1080	pixel	
Pixel Arrangement	RGB vertical stripe		
Display Mode	Normally Black		
Luminance of White	400 (Typ.)	cd/m <sup>2</sup>	

MODEL

LTA460HQ12-C03

Doc. No

06-000-G-20110721

Page

4 / 28

## 1. Absolute Maximum Ratings

If the condition exceeds maximum ratings, it can cause malfunction or unrecoverable damage to the device.

Item	Symbol	Min.	Max.	Unit	Note
Power Supply Voltage	$V_{DD}$	GND-0.5	13.2	V	(1)
Dimming Control	Max. Lum	-	5	V	
Storage temperature	$T_{STG}$	-20	60	°C	(2)
Operating temperature	$T_{OPR}$	0	50	°C	
Surface temperature	$T_{SUR}$	0	60	°C	(3)
Shock ( non - operating )	X,Y,Z	-	30	G	(4)
Vibration ( non - operating )	$V_{NOP}$	-	1.5	G	(5)

Note (1)  $T_a = 25 \pm 2 \text{ }^\circ\text{C}$

(2) Temperature and relative humidity range are shown in the figure below.

a. 90 % RH Max. ( $T_a \leq 39 \text{ }^\circ\text{C}$ )

b. Relative Humidity is 90% or less. ( $T_a > 39 \text{ }^\circ\text{C}$ )

c. No condensation

(3) Although abnormal visual problems can be occurred in  $T_{SUR}$  range, the polarizer is not damaged in this range.

(4) 11ms, sine wave, one time for  $\pm X, \pm Y, \pm Z$  axis

(5) 10-300 Hz, Sweep rate 10min, 30min for X,Y,Z axis

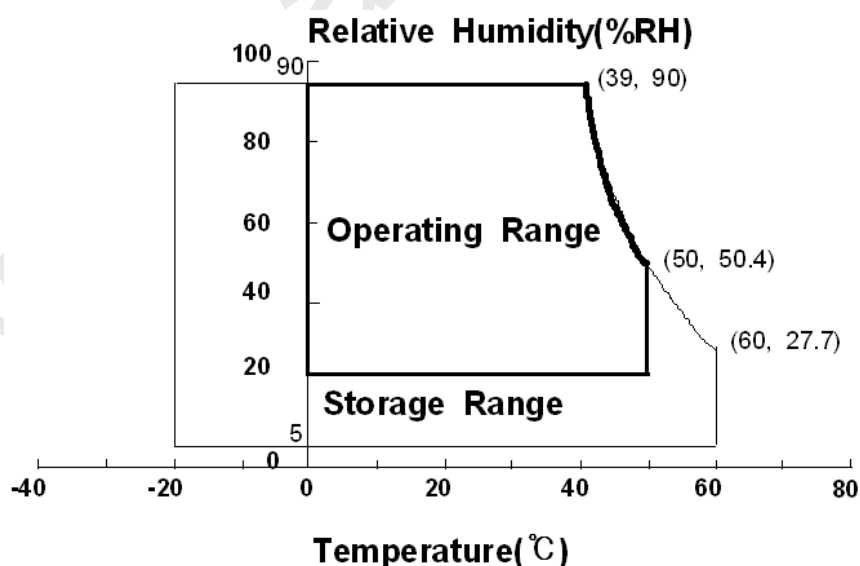

Fig. Temperature and Relative humidity range

## 2. Optical Characteristics

The optical characteristics should be measured in a dark room or equivalent.

Measuring equipment : TOPCON RD-80S, TOPCON SR-3, ELDIM EZ-Contrast

( $T_a = 25 \pm 2^\circ\text{C}$ ,  $V_{DD}=12\text{V}$ ,  $f_v=120\text{Hz}$ ,  $f_{DCLK}=148.5\text{MHz}$ , LED Current = 140 mA)

Item	Symbol	Condition	Min.	Typ.	Max.	Unit	Note	
Contrast Ratio (Center of screen)	C/R		3,000	4,000	-		(1) SR-3	
Response Time	G-to-G	Tg	-	6	-	msec	(3) RD-80S	
Luminance of White (Center of screen)	$Y_L$		350	400	-	cd/m <sup>2</sup>	(4) SR-3	
Color Chromaticity (CIE 1931)	Red	Rx	Normal $q_{L,R}=0$ $q_{U,D}=0$  Viewing Angle	0.650	TYP. -0.03	TYP. +0.03	(5),(6) SR-3	
		Ry		0.330				
	Green	Gx		0.310				
		Gy		0.600				
	Blue	Bx		0.150				
		By		0.060				
	White	Wx		0.280				
		Wy		0.290				
Color Gamut	-		-	72	-	%	(5) SR-3	
Color Temperature	-		-	10,000	-	K		
Viewing Angle	Hor.	$q_L$	C/R $\geq$ 10	75	89	-	Degree	(6) EZ-Contrast
		$q_R$		75	89	-		
	Ver.	$q_U$		75	89	-		
		$q_D$		75	89	-		
White Brightness Uniformity (9 Points)	$B_{uni}$		-	-	25	%	(2) SR-3	

### - Test Equipment Setup

The measurement should be executed in a stable, windless and dark room between 40min and 60min after lighting the back light at the given temperature for stabilization of the back light. This should be measured in the center of screen.

Environment condition :  $T_a = 25 \pm 2^\circ\text{C}$

MODEL	LTA460HQ12-C03	Doc. No	06-000-G-20110721	Page	6 / 28
-------	----------------	---------	-------------------	------	--------

Photo detector	Field
SR-3	2°
RD-80S	1°

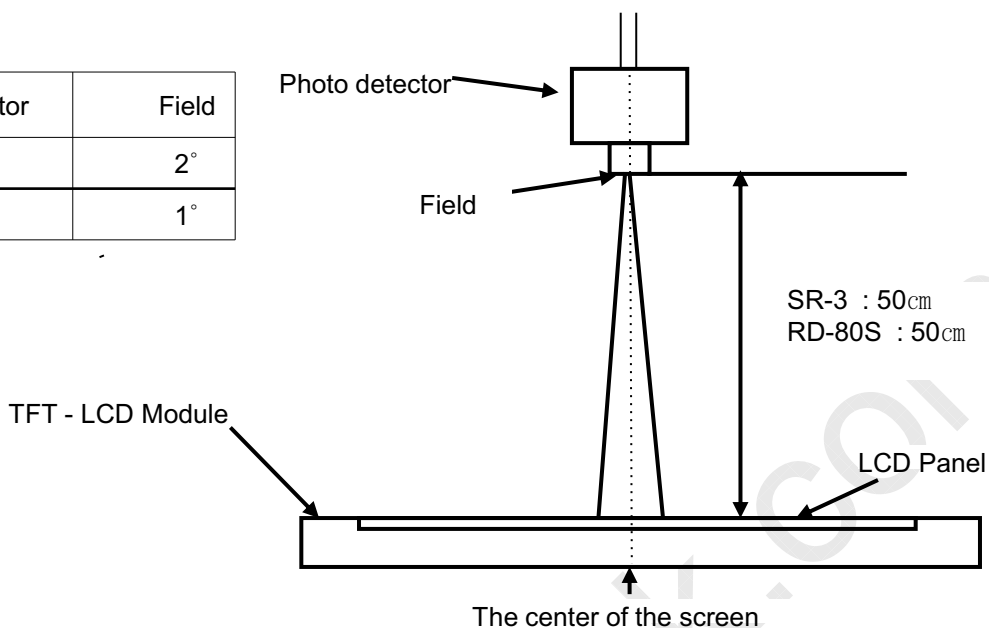

- Definition of test point

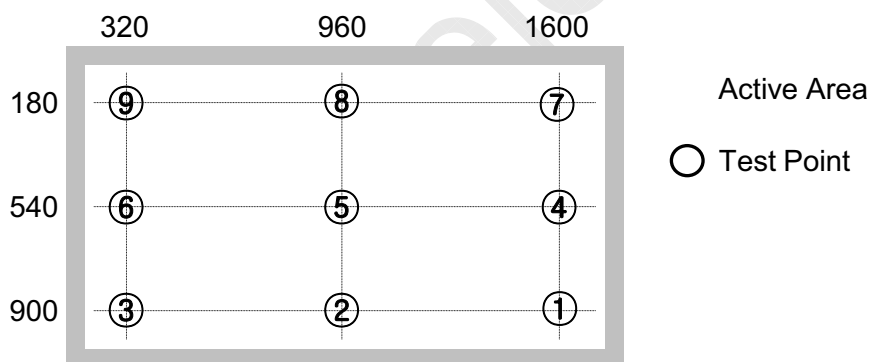

Note (1) Definition of Contrast Ratio (C/R)

: Ratio of gray max (Gmax) & gray min (Gmin) at the center point ⑤ of the panel

$$C/R = \frac{G_{max}}{G_{min}}$$

Gmax : Luminance with all pixels white

Gmin : Luminance with all pixels black

MODEL	LTA460HQ12-C03	Doc. No	06-000-G-20110721	Page	7 / 28
-------	----------------	---------	-------------------	------	--------

Note (2) Definition of 9 points brightness uniformity (Test pattern : Full White )

$$B_{uni} = 100 * \frac{(B_{max} - B_{min})}{B_{max}}$$

Bmax : Maximum brightness

Bmin : Minimum brightness

Note (3) Definition of Response time : Sum of Tr, Tf

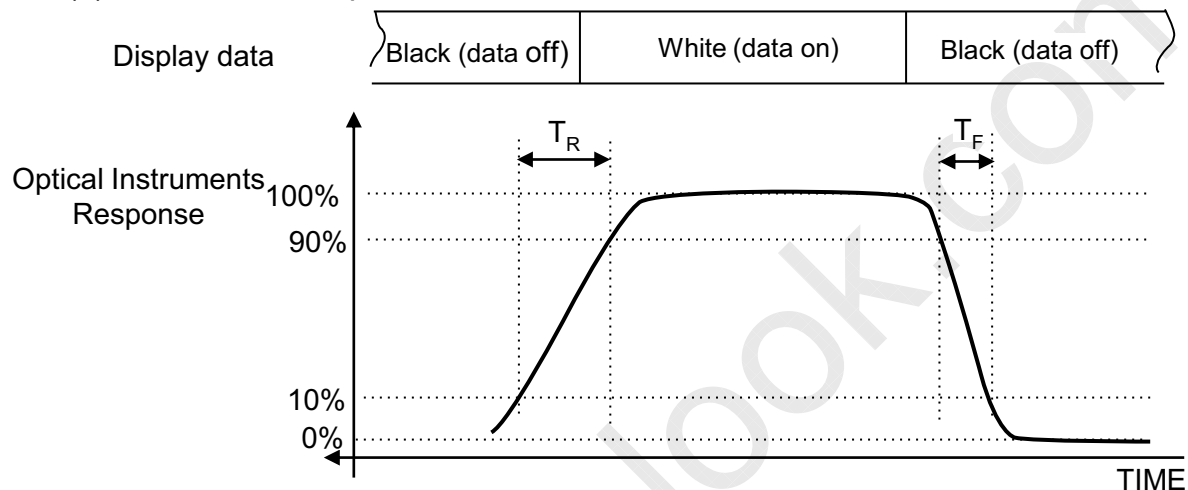

Note (4) Definition of Luminance of White : Luminance of white at center point ⑤

Note (5) Definition of Color Chromaticity (CIE 1931)

Color coordinate of Red, Green, Blue & White at center point ⑤

Note (6) Definition of Viewing Angle

: Viewing angle range (C/R  $\geq 10$ )

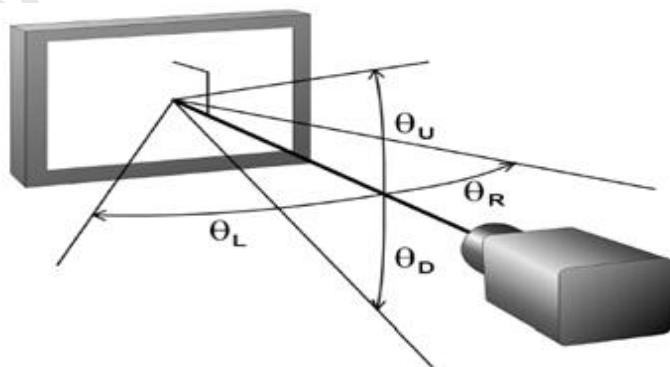



### 3. Electrical Characteristics

#### 3.1 TFT LCD Module

The connector for display data & timing signal should be connected.

$T_a = 25^\circ\text{C} \pm 2^\circ\text{C}$

Item	Symbol	Min.	Typ.	Max.	Unit	Note
Voltage of Power Supply	$V_{DD}$	10.8	12.0	13.2	V	(1)
Current of Power Supply	(a) Black	-	1200	1500	mA	(2),(3)
	(b) White	-	1300	1500	mA	
	(c) H-STRIPE	-	2000	2500	mA	
Vsync Frequency	$f_V$	95	120.0	125	Hz	
Hsync Frequency	$f_H$	120	135.0	140	kHz	
Main Frequency	$f_{DCLK}$	260	297.0	305	MHz	
Rush Current	$I_{RUSH}$	-	6	8	A	(4)

Note (1) The ripple voltage should be controlled under 10% of  $V_{DD}$ .

(2)  $f_V=120\text{Hz}$ ,  $f_{DCLK} = 297.0\text{MHz}$ ,  $V_{DD} = 12.0\text{V}$ , DC Current.

(3) Power dissipation check pattern (LCD Module only)

a) Black Pattern

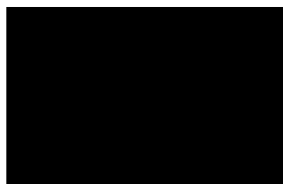

b) White Pattern



c) H-STRIPE

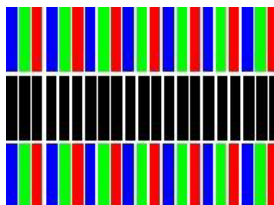

(4) Measurement Conditions

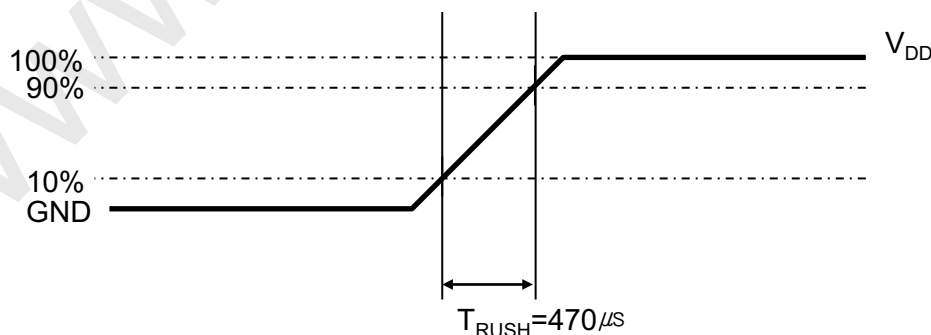

Rush Current  $I_{RUSH}$  can be measured when  $T_{RUSH}$  is  $470 \mu\text{s}$ .

MODEL

LTA460HQ12-C03

Doc. No

06-000-G-20110721

Page

9 / 28

### 3.2 Back Light Unit

The back light unit contains Edge type White LEDs (Light Emitting Diode)

$T_a = 25 \pm 2^\circ\text{C}$

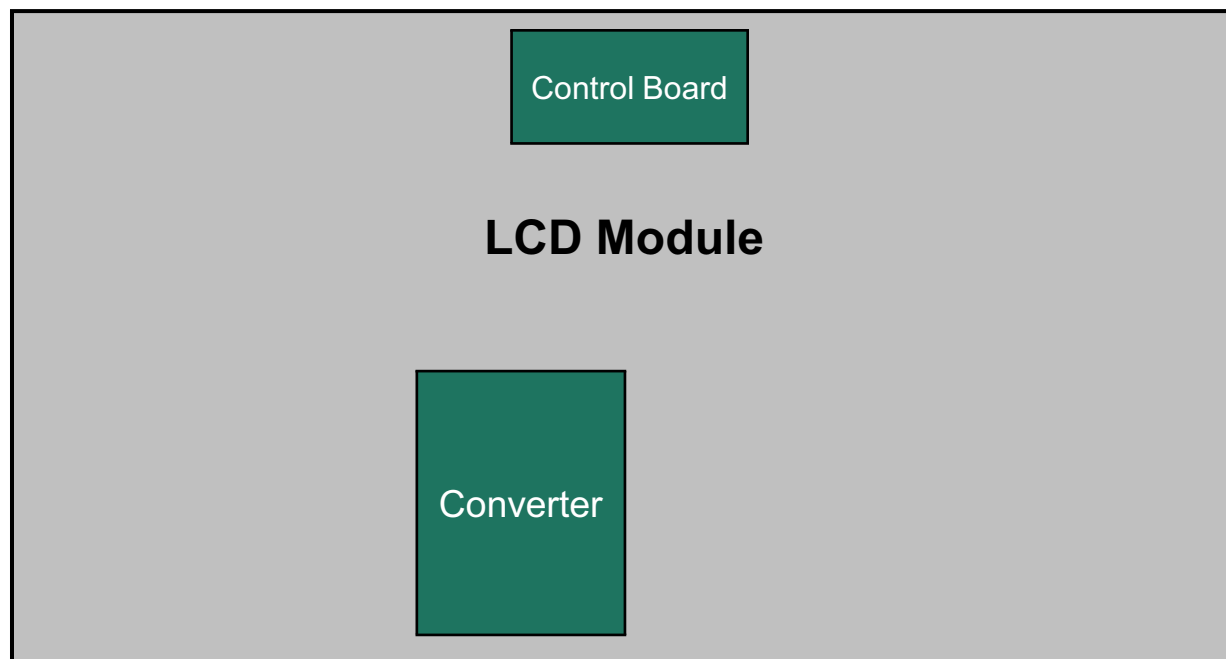

Item	Symbol	Min.	Typ.	Max.	Unit	Note
Operating Life Time	Hr	30,000	-	-	Hour	(1)

Note (1) It is defined as the time to take until the brightness reduces to 50% of its original value.

[Operating condition :  $T_a = 25 \pm 2^\circ\text{C}$ ]

MODEL

LTA460HQ12-C03

Doc. No

06-000-G-20110721

Page

10 / 28

### 3.3 converter Input Condition & Specification

Items	Symbol	Conditions	Specifications			Unit	Note
			Min.	Typ.	Max.		
Input Voltage	V <sub>in</sub>	-	22	24	26	V	Ta=25±2 °C
Input Current	I <sub>RUSH</sub>	V <sub>in</sub> =24.0V V <sub>dim</sub> =3.3V	-	-	7.1	A	
Output Current	I <sub>O(2D)</sub>	V <sub>in</sub> = 24.0V V <sub>dim</sub> =3.3 V	133	140	147	mA	Note (1)
	I <sub>O(3D)</sub>	3D ENA = ON	228	240	252		
Backlight On/Off	ON	V <sub>in</sub> =24.0 V	2.4	-	5.5	V	
	OFF	V <sub>in</sub> =24.0 V	0	-	0.8		
Dimming Range	V <sub>DIM</sub>	V <sub>in</sub> :22~26V	0	-	3.3	V	Note(2)
Dimming Duty Output	D max	V <sub>in</sub> =24V Dim:3.3V	100	-	-	%	
	D min	V <sub>in</sub> =24V Dim:0V	-	1	-		
Dimming Frequency	F <sub>PWM</sub>	V <sub>in</sub> =24.0 V	140	150	160	Hz	
External Dimming Duty Range	EX_Dim	V <sub>in</sub> =22.0~26.0 V Dim Pin(#13):floating	1	-	100	%	
External Dimming Frequency Range	F <sub>EX_PWM</sub>		95	-	200	Hz	
External Dimming Signal Level	V <sub>PWM</sub>	High (ON)	2.4	-	5.5	V	
		Low (Off)	0	-	0.8		

Note (1) All data is measured after 120min warm-up.

Note (2) V<sub>Dim</sub> and Ex\_Dim are available only at Normal 2D mode. (3D ENA = OFF)

Note (3) Duty = On / (On+Off) \* 100

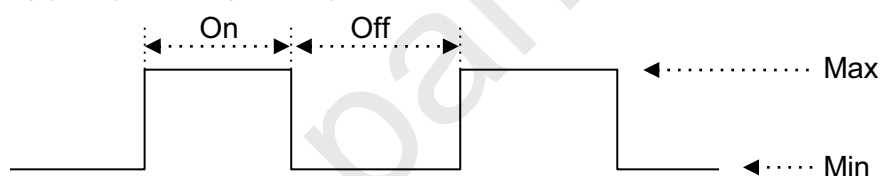

- Additional Appendix for Supply Current (Only for Reference\_2D mode)

Items	Symbol	Conditions	Min.	Typ.	Max.	Unit
Input Current	lin_overshoot	V <sub>in</sub> = 24V, Dim=3.3V (Within 1hr at BLU on)	-	3.5	3.6	A
	lin_saturation	V <sub>in</sub> = 24V, Dim=3.3V (After 1hr Aging)	-	3.2	3.3	A
Power Consumption (Back light)	P_Inrush	V <sub>in</sub> =24.0V, V <sub>dim</sub> = 3.3V	-	-	170	Watt
	P_overshoot	V <sub>in</sub> = 24V, Dim=3.3V (Within 1hr at BLU on)	-	84	87	Watt
	P_saturation	V <sub>in</sub> = 24V, Dim=3.3V (After 1hr Aging)	-	77	80	Watt

MODEL

LTA460HQ12-C03

Doc. No

06-000-G-20110721

Page

11 / 28

## 4. Input Terminal Pin Assignment

### 4.1.1 Input Signal & Power

Connector : FI-RE41S-HF (JAE/UJU)

Pin	Description		Pin	Symbol	Description
1	Vdd(12V)		21	ODD LVDS SIGNAL	Rx1[3]P
2	Vdd(12V)		22		Rx1[4]N (note 5)
3	Vdd(12V)		23		Rx1[4]P (note 5)
4	Vdd(12V)		24		GND
5	Vdd(12V)		25		Rx3[0]N
6	No Connection		26		Rx3[0]P
7	GND		27		Rx3[1]N
8	GND		28		Rx3[1]P
9	GND		29		Rx3[2]N
10	ODD LVDS SIGNAL	Rx1[0]N	30		Rx3[2]P
11		Rx1[0]P	31		GND
12		Rx1[1]N	32		Rx3CLK-
13		Rx1[1]P	33		Rx3CLK+
14		Rx1[2]N	34		GND
15		Rx1[2]P	35		Rx3[3]N
16		GND	36		Rx3[3]P
17		Rx1CLK-	37		Rx3[4]N (note 5)
18		Rx1CLK+	38		Rx3[4]P (note 5)
19		GND	39		GND
20	Rx1[3]N	40	No Connection		
		41	No Connection		

Note) No Connection : This PINS Should be disconnected because of SEC internal design.

MODEL

LTA460HQ12-C03

Doc. No

06-000-G-20110721

Page

12 / 28

## 4.1.2 Input Signal &amp; Power

Connector : FI-RE51S-HF (JAE/UJU)

Pin	Description	Pin	Description
1	Vdd(12V)	26	Rx4[0]P
2	Vdd(12V)	27	Rx4[1]N
3	Vdd(12V)	28	Rx4[1]P
4	Vdd(12V)	29	Rx4[2]N
5	Vdd(12V)	30	Rx4[2]P
6	No Connection	31	GND
7	GND	32	Rx4CLK-
8	GND	33	Rx4CLK+
9	GND	34	GND
10	Rx2[0]N	35	Rx4[3]N
11	Rx2[0]P	36	Rx4[3]P
12	Rx2[1]N	37	Rx4[4]N (note 5)
13	Rx2[1]P	38	Rx4[4]P (note 5)
14	Rx2[2]N	39	GND
15	Rx2[2]P	40	No Connection
16	GND	41	No Connection
17	Rx2CLK-	42	3D_EN 3D_EN signal (Note 2)
18	Rx2CLK+	43	No Connection
19	GND	44	No Connection
20	Rx2[3]N	45	No Connection
21	Rx2[3]P	46	No Connection
22	Rx2[4]N (note 5)	47	No Connection
23	Rx2[4]P(note 5)	48	3D_SYNC_I Shutter glass Sync Input signal (Note 2) (Note 3)
24	GND	49	3D_SYNC_O Shutter glass Sync Signal
25	Rx4[0]N	50	No Connection
		51	No Connection

Note ) No Connection : This PINS Should be disconnected because of SEC internal design.

Note (1) SEC internal Only: These PINS are used only for SAMSUNG. (DO NOT CONNECT)

Note (2) 3D Enable / 3D sync\_I signal voltage level

High : Min 2.7V, Max 3.3 V Low : Min 0 V, Max 0.4V

MODEL	LTA460HQ12-C03	Doc. No	06-000-G-20110721	Page	13 / 28
-------	----------------	---------	-------------------	------	---------

Note3) Recommend timing for 3D\_SYNC\_I Signal .

- Guide Signal to Separate L frame and R frame
- Shutter glass signal & Operation timing also depend on this signal
- To operate 3D function, need this signal from Set A/D board.  
(In Order for using it in 2D mode, change the input condition into GND)

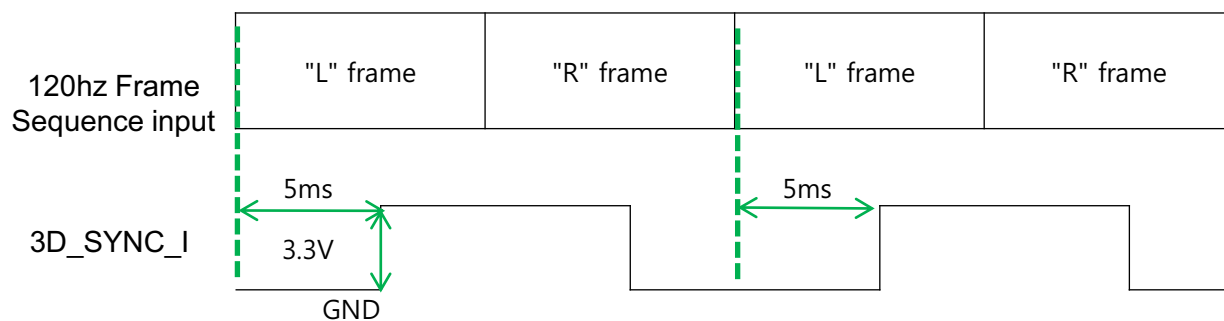

Note4) Pin number starts from Right side

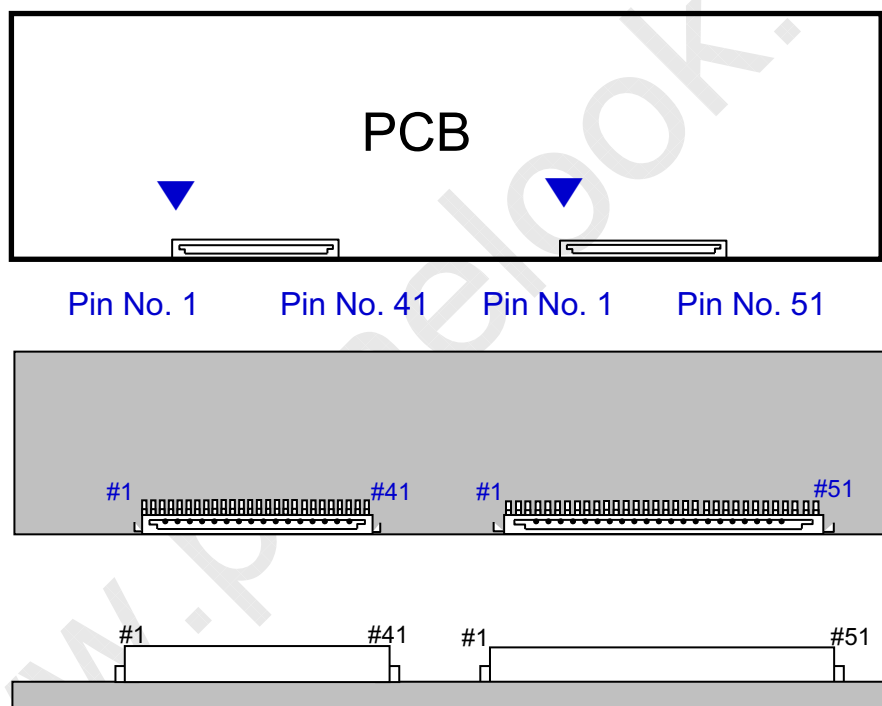

Fig. Connector diagram

- All GND pins should be connected together and also be connected to the LCD's metal chassis.
- All power input pins should be connected together.
- All NC pins should be separated from other signal or power.

Note 5) If Set use 8bit input mode, signals of LVDS [4] channel should be '0' Level  
(\* Level '0' : Negative > (Positive + LVDS Input Minimum) )  
Level of LVDS signals are base on page 18, 5.2.

MODEL	LTA460HQ12-C03	Doc. No	06-000-G-20110721	Page	14 / 28
-------	----------------	---------	-------------------	------	---------

## 4.2. converter Input Pin Configuration

Connector : Yeon-ho, 20022WR-14B1

Pin No.	Pin Configuration(FUNCTION)
	Master
1 ~5	24 V
6~10	GND
11	Error Out
12	Backlight On /Off [ON:2.4 – 5.5 V, OFF: 0 - 0.8 V]
13	Dimming Control [0V:Min, 3.3V:Max] *Note(1)
14	External PWM [1~100 %] *Note(1)

Note(1) If use Dimming Control, Pin 14 Must be N.C  
If use External PWM, Pin 13 Must be N.C

## 4.3. converter Input Power Sequence

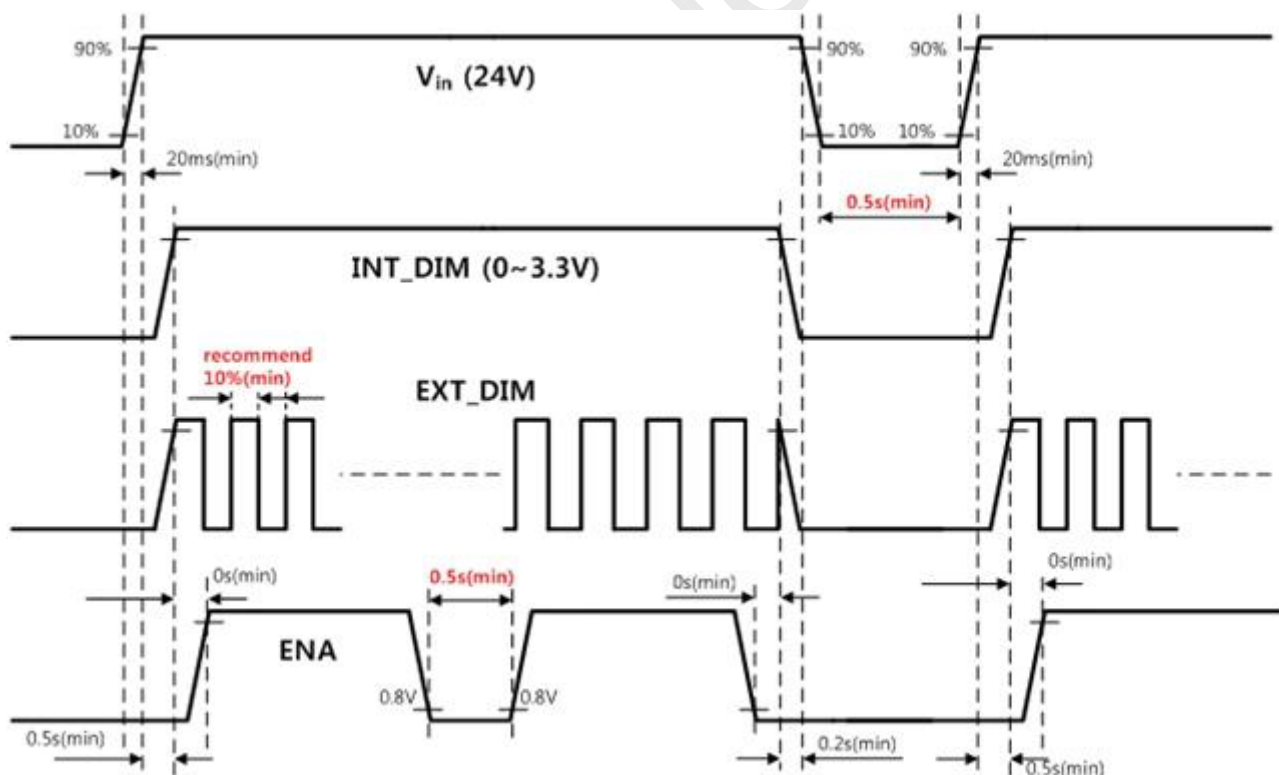

Note) SEQUENCE : ON =  $V_{in}(24V) > \text{Dimming Control} \geq \text{Backlight On/Off}$   
OFF =  $\text{Backlight On/Off} \geq \text{Dimming Control} > V_{in}(24V)$

MODEL

LTA460HQ12-C03

Doc. No

06-000-G-20110721

Page

15 / 28

## 4.4 LVDS Interface

- LVDS Receiver : T-con (merged)
- Data Format (JEIDA Only)

	LVDS pin	JEIDA -DATA
TxOUT/RxIN0	TxIN/RxOUT0	R4
	TxIN/RxOUT1	R5
	TxIN/RxOUT2	R6
	TxIN/RxOUT3	R7
	TxIN/RxOUT4	R8
	TxIN/RxOUT6	R9
	TxIN/RxOUT7	G4
TxOUT/RxIN1	TxIN/RxOUT8	G5
	TxIN/RxOUT9	G6
	TxIN/RxOUT12	G7
	TxIN/RxOUT13	G8
	TxIN/RxOUT14	G9
	TxIN/RxOUT15	B4
	TxIN/RxOUT18	B5
TxOUT/RxIN2	TxIN/RxOUT19	B6
	TxIN/RxOUT20	B7
	TxIN/RxOUT21	B8
	TxIN/RxOUT22	B9
	TxIN/RxOUT24	HSYNC
	TxIN/RxOUT25	VSYNC
	TxIN/RxOUT26	DEN
TxOUT/RxIN3	TxIN/RxOUT27	R2
	TxIN/RxOUT5	R3
	TxIN/RxOUT10	G2
	TxIN/RxOUT11	G3
	TxIN/RxOUT16	B2
	TxIN/RxOUT17	B3
	TxIN/RxOUT23	RESERVED
TxOUT/RxIN4	TxIN/RxOUT28	R0
	TxIN/RxOUT29	R1
	TxIN/RxOUT30	G0
	TxIN/RxOUT31	G1
	TxIN/RxOUT32	B0
	TxIN/RxOUT33	B1
	TxIN/RxOUT34	RESERVED

MODEL

LTA460HQ12-C03

Doc. No

06-000-G-20110721

Page

16 / 28



### 4.5 Input Signals, Basic Display Colors and Gray Scale of Each Color

COLOR	DISPLAY (10bit)	DATA SIGNAL																												GRAY SCALE LEVEL	
		RED									GREEN									BLUE											
		R0	R1	R2	R3	R4	R5	R6	R7	R8	R9	G0	G1	G2	G3	G4	G5	G6	G7	G8	G9	B0	B1	B2	B3	B4	B5	B6	B7		B8
BASIC COLOR	BLACK	0	0	0	0	0	0	0	0	0	0	0	0	0	0	0	0	0	0	0	0	0	0	0	0	0	0	0	0	0	-
	BLUE	0	0	0	0	0	0	0	0	0	0	0	0	0	0	0	0	0	0	0	0	1	1	1	1	1	1	1	1	1	-
	GREEN	0	0	0	0	0	0	0	0	0	0	1	1	1	1	1	1	1	1	1	1	0	0	0	0	0	0	0	0	0	-
	CYAN	0	0	0	0	0	0	0	0	0	0	1	1	1	1	1	1	1	1	1	1	1	1	1	1	1	1	1	1	1	-
	RED	1	1	1	1	1	1	1	1	1	1	0	0	0	0	0	0	0	0	0	0	0	0	0	0	0	0	0	0	0	-
	MAGENTA	1	1	1	1	1	1	1	1	1	1	0	0	0	0	0	0	0	0	0	0	1	1	1	1	1	1	1	1	1	-
	YELLOW	1	1	1	1	1	1	1	1	1	1	1	1	1	1	1	1	1	1	1	1	0	0	0	0	0	0	0	0	0	-
WHITE	1	1	1	1	1	1	1	1	1	1	1	1	1	1	1	1	1	1	1	1	1	1	1	1	1	1	1	1	1	-	
GRAY SCALE OF RED	BLACK	0	0	0	0	0	0	0	0	0	0	0	0	0	0	0	0	0	0	0	0	0	0	0	0	0	0	0	0	R0	
	DARK ↑	1	0	0	0	0	0	0	0	0	0	0	0	0	0	0	0	0	0	0	0	0	0	0	0	0	0	0	0	R1	
		0	1	0	0	0	0	0	0	0	0	0	0	0	0	0	0	0	0	0	0	0	0	0	0	0	0	0	0	R2	
		:	:	:	:	:	:	:	:	:	:	:	:	:	:	:	:	:	:	:	:	:	:	:	:	:	:	:	:	R3~R1020	
		:	:	:	:	:	:	:	:	:	:	:	:	:	:	:	:	:	:	:	:	:	:	:	:	:	:	:	:		
	↓ LIGHT	1	0	1	1	1	1	1	1	1	1	0	0	0	0	0	0	0	0	0	0	0	0	0	0	0	0	0	0	R1021	
	0	1	1	1	1	1	1	1	1	1	1	0	0	0	0	0	0	0	0	0	0	0	0	0	0	0	0	0	0	R1022	
RED	1	1	1	1	1	1	1	1	1	1	0	0	0	0	0	0	0	0	0	0	0	0	0	0	0	0	0	0	R1023		
GRAY SCALE OF GREEN	BLACK	0	0	0	0	0	0	0	0	0	0	0	0	0	0	0	0	0	0	0	0	0	0	0	0	0	0	0	0	G0	
	DARK ↑	0	0	0	0	0	0	0	0	0	0	1	0	0	0	0	0	0	0	0	0	0	0	0	0	0	0	0	0	G1	
		0	0	0	0	0	0	0	0	0	0	1	0	0	0	0	0	0	0	0	0	0	0	0	0	0	0	0	0	G2	
		:	:	:	:	:	:	:	:	:	:	:	:	:	:	:	:	:	:	:	:	:	:	:	:	:	:	:	:	G3~G1020	
		:	:	:	:	:	:	:	:	:	:	:	:	:	:	:	:	:	:	:	:	:	:	:	:	:	:	:	:		
	↓ LIGHT	0	0	0	0	0	0	0	0	0	0	1	0	1	1	1	1	1	1	1	1	0	0	0	0	0	0	0	0	G1021	
	0	0	0	0	0	0	0	0	0	0	0	1	1	1	1	1	1	1	1	1	1	0	0	0	0	0	0	0	0	G1022	
GREEN	0	0	0	0	0	0	0	0	0	0	1	1	1	1	1	1	1	1	1	1	0	0	0	0	0	0	0	0	G1023		
GRAY SCALE OF BLUE	BLACK	0	0	0	0	0	0	0	0	0	0	0	0	0	0	0	0	0	0	0	0	0	0	0	0	0	0	0	0	B0	
	DARK ↑	0	0	0	0	0	0	0	0	0	0	0	0	0	0	0	0	0	0	0	0	1	0	0	0	0	0	0	0	B1	
		0	0	0	0	0	0	0	0	0	0	0	0	0	0	0	0	0	0	0	0	0	1	0	0	0	0	0	0	B2	
		:	:	:	:	:	:	:	:	:	:	:	:	:	:	:	:	:	:	:	:	:	:	:	:	:	:	:	:	B3~B1020	
		:	:	:	:	:	:	:	:	:	:	:	:	:	:	:	:	:	:	:	:	:	:	:	:	:	:	:	:		
	↓ LIGHT	0	0	0	0	0	0	0	0	0	0	0	0	0	0	0	0	0	0	0	0	1	0	1	1	1	1	1	1	B1021	
	0	0	0	0	0	0	0	0	0	0	0	0	0	0	0	0	0	0	0	0	0	1	1	1	1	1	1	1	1	B1022	
BLUE	0	0	0	0	0	0	0	0	0	0	0	0	0	0	0	0	0	0	0	0	1	1	1	1	1	1	1	1	B1023		

Note) Definition of Gray :

Rn : Red Gray, Gn : Green Gray, Bn : Blue Gray (n = Gray level)

Input Signal : 0 = Low level voltage, 1 = High level voltage

<b>MODEL</b>	<b>LTA460HQ12-C03</b>	<b>Doc. No</b>	<b>06-000-G-20110721</b>	<b>Page</b>	<b>17 / 28</b>
--------------	-----------------------	----------------	--------------------------	-------------	----------------

## 5. Interface Timing

### 5.1 Timing Parameters ( DE mode )

SIGNAL	ITEM	SYMBOL	MIN.	TYP.	MAX.	Unit	NOTE
Clock	Frequency	$1/T_C$	260	297.0	305	MHz	-
Hsync		$F_H$	120	135.0	140	KHz	-
Vsync		$F_V$	95	120.0	125	Hz	-
Vertical Display Term	Active Display Period	$T_{VD}$	-	1080	-	Lines	-
	Vertical Total	$T_V$	1110	1125	1380	Lines	-
Horizontal Display Term	Active Display Period	$T_{HD}$	-	1920	-	Clocks	-
	Horizontal Total	$T_H$	2112	2200	2352	clocks	-

Note) This product is DE mode. But the Hsync & Vsync signal must be inputted

- (1) Test Point : TTL control signal and CLK at LVDS Tx input terminal in system
- (2) Internal VDD = 3.3V
- (3) Spread spectrum
  - Modulation rate (max) :  $\pm 1.5\%$
  - Modulation Frequency : under 100KHz

### 5.2 LVDS Input Data Characteristics

ITEM		SYMBOL	Min.	Typ.	Max.	UNIT	NOTE
Input Data Position	$F_{IN}=78\text{MHz}$	$t_{RSSM}$	-	-	450	ps	
		$t_{RSLM}$	-450	-	-	ps	
Input common mode voltage		$V_{CM}$	0.3	-	1.8	V	-
Differential Input Voltage		$ V_{ID} $	100	-	600	mV	-

Note) When the skew is measured the Spread Spectrum should be 0%



### 5.3 3D mode Sequence

#### 5.3.1 3D Sequence

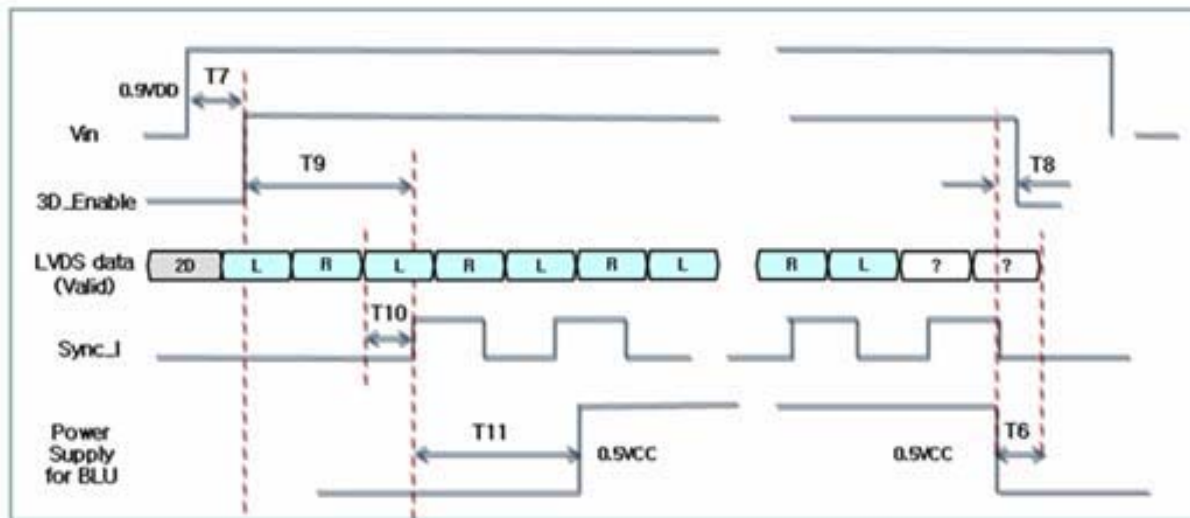

	Spec	Measured	Result		Spec	Measured	Result
T6	≥ 100 msec			T9	0 sec		
T7	≥ 2 sec			T10	Typ. 5 msec		
T8	≥ 0 sec			T11	≥ 1000msec		

※ T10 : Sync\_I is checked with Valid Active L frame

#### 5.3.2 Level of 3D Control signal

Test Items	Test Condition		Spec	
			Min	Max
3D Enable Level	C-PBA Input Level (Change to 3D mode)	High	2.7	3.3
		Low	0.0	0.4
3D_SYNC_I	C-PBA Input Level (L/R Sync)	High	2.7	3.3
		Low	0.0	0.4
3D_SYNC_O	Shutter Glasses Sync Level	High	2.7	3.3
		Low	0.0	0.4

## 5.4 Timing diagrams of interface signal ( DE mode )

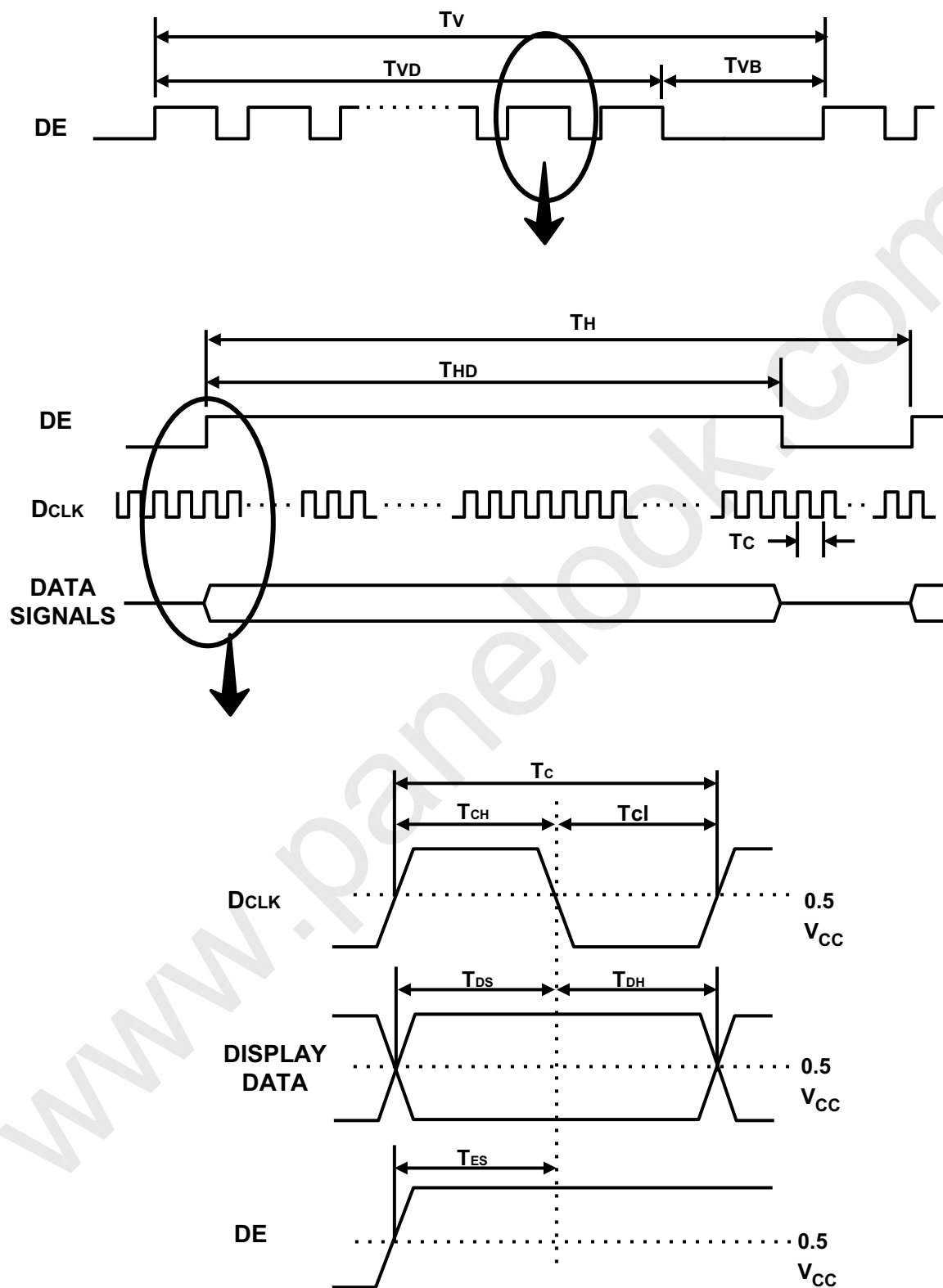

## 5.5 Power ON/OFF Sequence

To prevent a latch-up or DC operation of the LCD Module, the power on/off sequence should be as the diagram below.

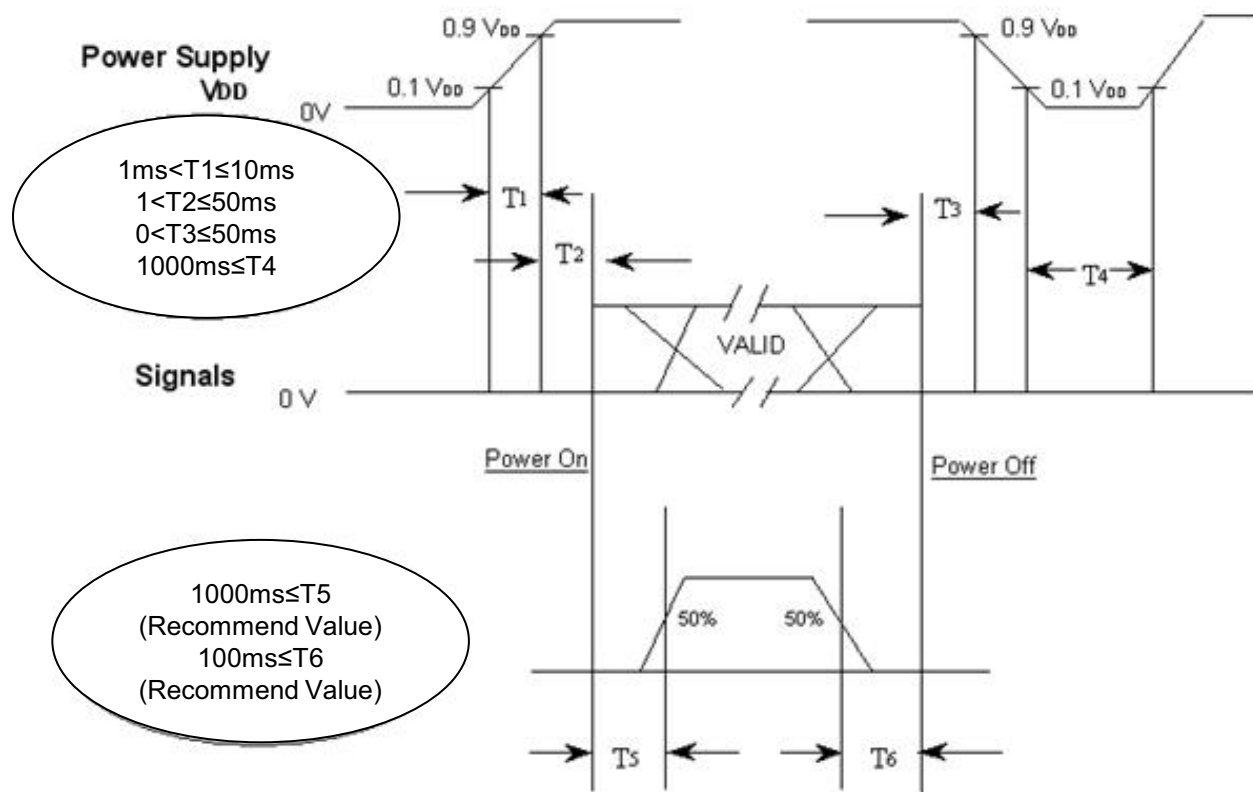

$T_1$  :  $V_{DD}$  rising time from 10% to 90%

$T_2$  : The time from  $V_{DD}$  to valid data at power ON.

$T_3$  : The time from valid data off to  $V_{DD}$  off at power Off.

$T_4$  :  $V_{DD}$  off time for Windows restart

$T_5$  : The time from valid data to B/L enable at power ON.

$T_6$  : The time from valid data off to B/L disable at power Off.

- The supply voltage of the external system for the Module input should be the same as the definition of  $V_{DD}$ .
- Apply the lamp voltage within the LCD operation range. When the back light turns on before the LCD operation or the LCD turns off before the back light turns off, the display may momentarily show abnormal screen.
- In case of  $V_{DD}$  = off level, please keep the level of input signals low or keep a high impedance.
- $T_4$  should be measured after the Module has been fully discharged between power off and on period.
- Interface signal should not be kept at high impedance when the power is on.
- In Case  $T_5$  is less than 1000msec and  $T_6$  is less than 100msec, Garbage Display can be seen. (It is not related to electrical function issue, Just for recommendation to prevent Garbage Display )

MODEL	LTA460HQ12-C03	Doc. No	06-000-G-20110721	Page	21 / 28
-------	----------------	---------	-------------------	------	---------

PART NAME CODE NO. SPECIFICATION Q'TY FINISH MATERIAL WEIGHT NUMBER IN MATERIAL REPAIRS

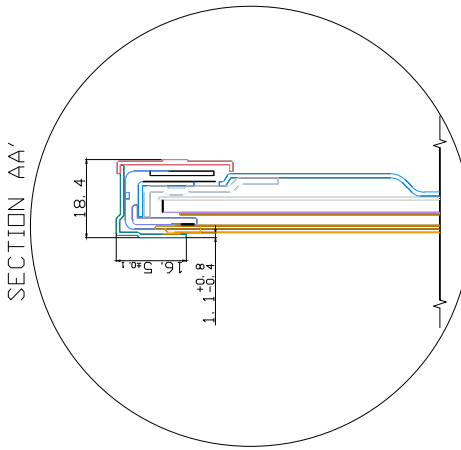

- NOTE
- BACKLIGHT A LED SUBSTRATE CONNECTION
  - CONDUCTIVE ADHESIVE POWER CONNECTOR
  - MAKER: YEEDING
  - MAKER: HP-1481
  - LAVIS INPUT CONNECTOR(SPTN)
  - MAKER: HP-1481
  - MAKER: HP-1481-S-HF
  - LAVIS INPUT CONNECTOR(4PFN)
  - MAKER: HP-1481-S-HF
  - PART NO. FT-2E415-HF
3. USERBOM & TOLERANCE DESIGNED FOR GENERAL PURPOSE METRIC
- TAP SIZE & TOLERANCE FOLLOWING TO GENERAL GRADE OF 'K5.8 0E11'
  - ALLIAD SCREW FOLLOWING TO GENERAL GRADE OF 'K5.8 0E11'
  - M3 TAP :  $0.35 \pm 0.04$  CH MAX
  - M3 TAP :  $0.25 \pm 0.03$  CH MAX
  - M3 TAP :  $0.25 \pm 0.04$  CH MAX
  - M3 TAP :  $0.25 \pm 0.03$  CH MAX
4. REPEATED INSERTION WARRANTY 4 TIMES SCREW.
5. WEIGHT : 9.00G MAX
6. BLACK MATRIX SPEC
- 1A - B15.00M
  - 1C - B15.00M

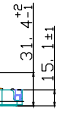
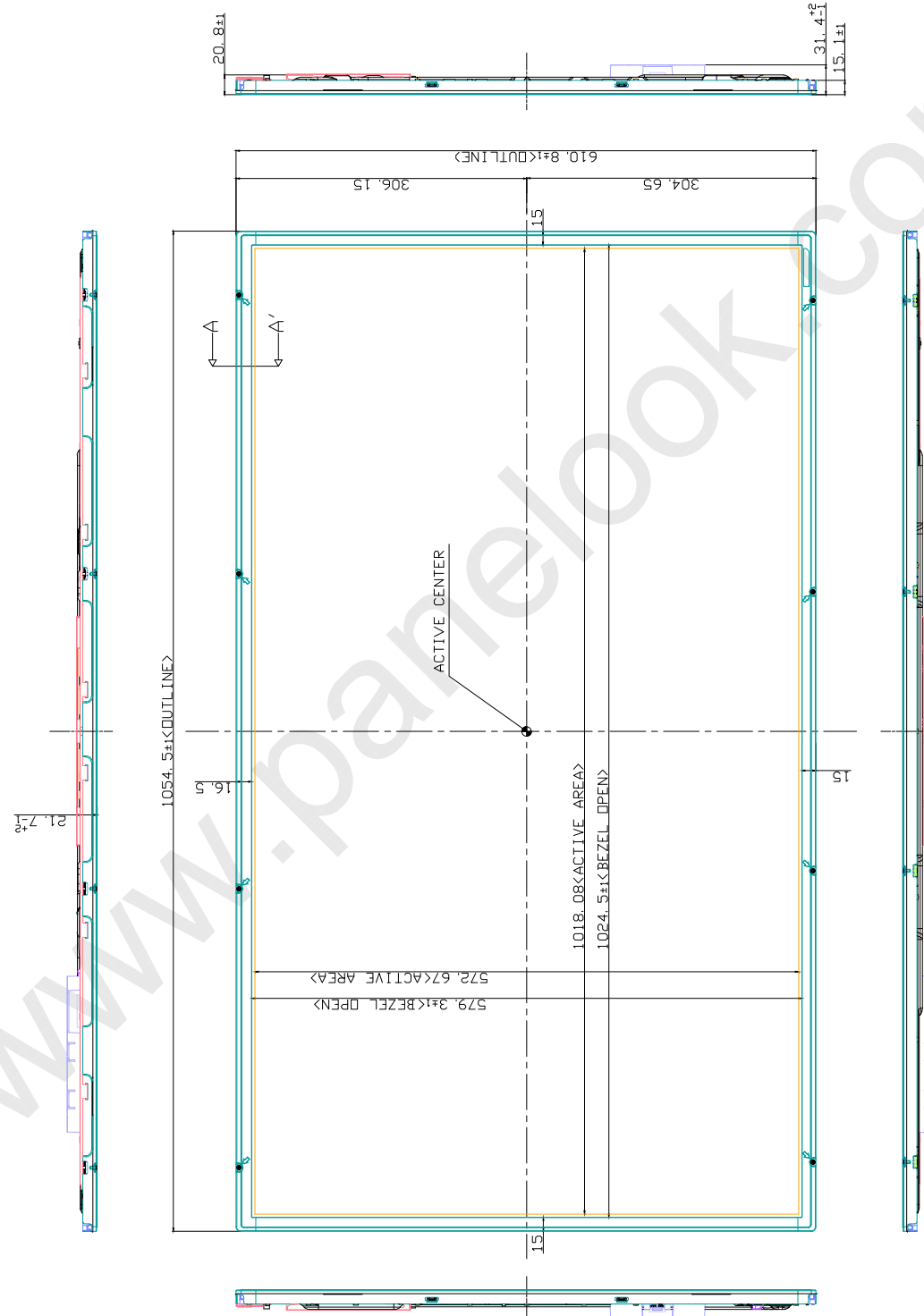
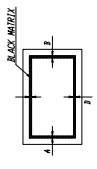

REV.	DATE	DESCRIPTION OF REVISION	APP'D. BY	MODEL NAME	PART/SHEET NAME	OUTLINE DIMENSION(S) SHEET 1/3
0	X X X X	40.05		BT014020		
1	X X X X	40.08				
2	X X X X	40.12				
3	X X X X	40.25				
4	X X X X	40.4				
5	X X X X	40.5				
6	X X X X	40.5				

GENERAL TOLERANCE						
STEP	LEVEL 1	LEVEL 2	LEVEL 3	UNIT	SCALE	LEVEL 3
0 < X X X X	40.05	40.1	40.2		1/25	40.3
1 < X X X X	40.08	40.15	40.3		1/25	40.5
2 < X X X X	40.12	40.25	40.5		1/25	40.5
3 < X X X X	40.25	40.4	40.8		1/25	40.8
4 < X X X X	40.4	40.5	40.8		1/25	40.8
5 < X X X X	40.5	40.8	40.8		1/25	40.8
6 < X X X X	40.5	40.8	40.8		1/25	40.8

PRELIMINARY

SAMSUNG ELECTRONICS

CHG'D BY	REASON
L1A6CHO12	OUTLINE DIMENSION(S) SHEET 1/3

A B C D E F G H I J K L M N O P  
 NO PART NAME CODE NO SPECIFICATION QTY FINISH MATERIAL WEIGHT NUMBER IN REPAIR  
 OUTLINE DIMENSION (MM)

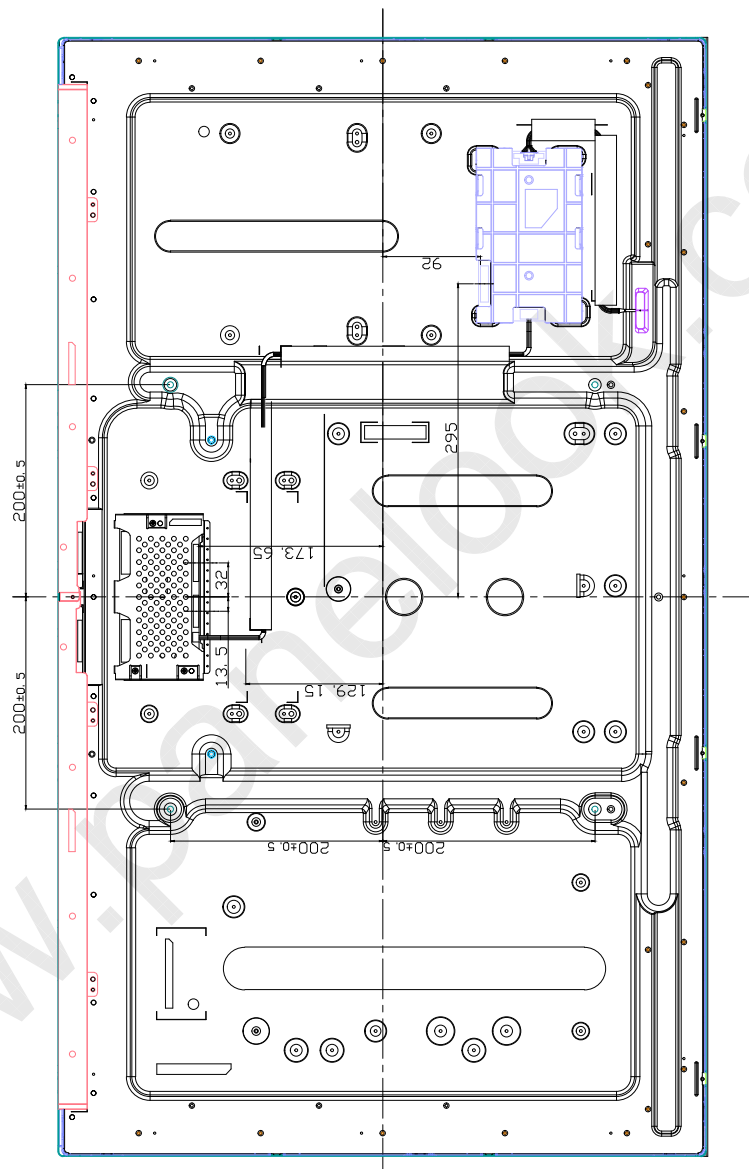

REV. DATE		DESCRIPTION OF REVISION		APP'D. BY	CHK'D. BY	REASON	CHG'D. BY
UNIT	NO.	DATE	BY				
SCALE	1/1.25						
LEVEL	2						
MODEL NAME						L1T460H012	
PART/SHEET NAME						OUTLINE DIMENSION BOOK	SHEET 12/12
SPEC. NO.							REV. 001
CODE NO.							

GENERAL TOLERANCE		LEVEL 1	LEVEL 2	LEVEL 3
STEP				
0 < X < 4		±0.05	±0.1	±0.2
4 < X < 16		±0.08	±0.15	±0.3
16 < X < 64		±0.12	±0.25	±0.5
64 < X < 256		±0.25	±0.4	±0.8

PRELIMINARY

## 7. PACKING

### 7.1 CARTON (Internal Package)

#### (1) Packing Form

Corrugated fiberboard box and corrugated cardboard as shock absorber

#### (2) Packing Method

**Packing  
-Pallet Box**

**LCD Module**

**Packing  
-Pallet Box**

**Pallet-Plastic**

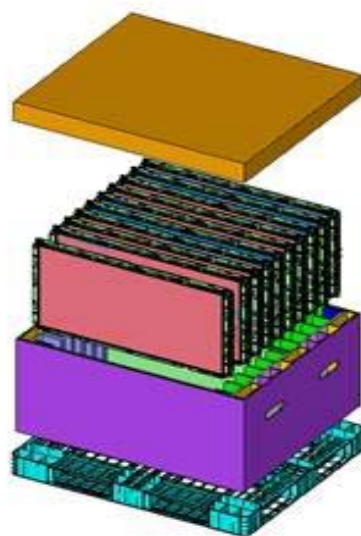

### 7.2 Packing Specification

Item	Specification	Remark
LCD Packing	22 ea / (Packing-Pallet Box)	1. 11.8 kg / LCD (22 ea) 2. 14 kg / Packing Set 3. Packing Material : Paper
Pallet	1Box / Pallet	1. Pallet weight = 8.8 kg
Packing Direction	Vertical	
Total Pallet Size	H x V x height	1270 mm (H) x 1150 mm (V) x 844 mm (height)
Total Pallet Weight	282.4 kg	Module (259.6 kg) + Packing SET (14 kg) +Pallet (8.8kg)

**MODEL**

**LTA460HQ12-C03**

**Doc. No**

**06-000-G-20110721**

**Page**

**24 / 28**





## 8. MARKING & OTHERS

A nameplate bearing followed by is affixed to a shipped product at the specified location on each product.

- (1) Part number : LTA460HQ12
- (2) Revision: Three letters
- (3) Lot number : X X X X XXX XX X

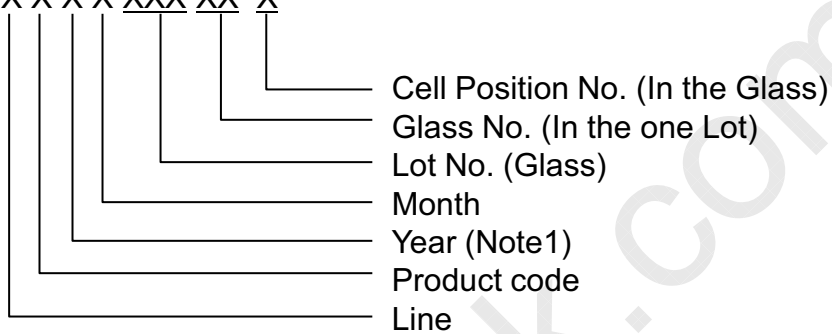

### (4) Nameplate Indication

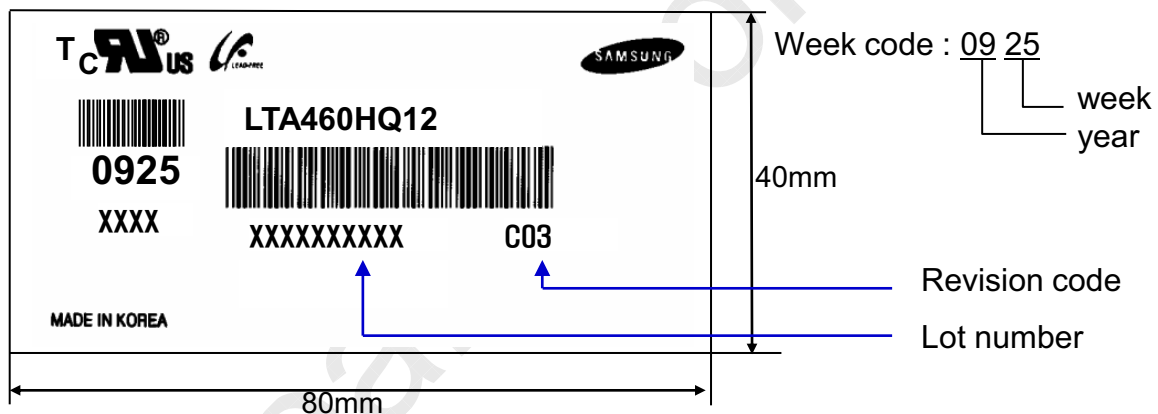

### (5) Packing box attach

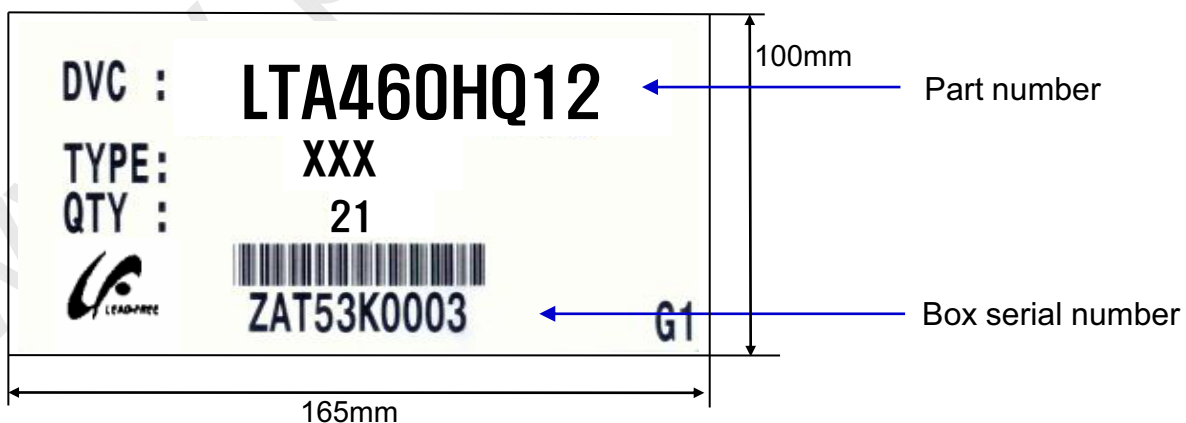

### (6) Others

- 1. After service part  
 Lamps cannot be replaced because of the narrow bezel structure.

MODEL	LTA460HQ12-C03	Doc. No	06-000-G-20110721	Page	25 / 28
-------	----------------	---------	-------------------	------	---------

## 9. General Precautions

### 9.1 Handling

- (a) When the Module is assembled, it should be attached to the system firmly using all mounting holes. Be careful not to twist and bend the Module.
- (b) Because the converter use high voltage, it should be disconnected from power before it is assembled or disassembled.
- (c) Refrain from strong mechanical shock and / or any force to the Module.  
In addition to damage, this may cause improper operation or damage to the Module and LED back light.
- (d) Note that polarizers are very fragile and could be damage easily.  
Do not press or scratch the surface harder than a HB pencil lead.
- (e) Wipe off water droplets or oil immediately. If you leave the droplets for a long time, staining or discoloration may occur.
- (f) If the surface of the polarizer is dirty, clean it using absorbent cotton or soft cloth.
- (g) Desirable cleaners are water, IPA(Isopropyl Alcohol) or Hexane.  
Do not use Ketone type materials(ex. Acetone), Ethyl alcohol, Toluene, Ethyl acid or Methyl chloride. It might permanent damage to the polarizer due to chemical reaction.
- (h) If the liquid crystal material leaks from the panel, it should be kept away from the eyes or mouth . In case of contact with hands, legs or clothes, it must be washed away with soap thoroughly.
- (i) Protect the module from Electrostatic discharge. Otherwise the ASIC IC or semiconductor would be damaged.
- (j) Use finger-stalls with soft gloves in order to keep display clean during the incoming inspection and assembly process.
- (k) Do not disassemble the Module.
- (l) Do not disassemble shield case of converter & LVDS board
- (m) Do not connect N.C pins. (Samsung internal use only)
- (n) Protection film for polarizer on the Module should be slowly peeled off just before use so that the electrostatic charge can be minimized. Must put on antistatic glove while handling a module
- (o) Pins of I/F connector should not be touched directly with bare hands.

<b>MODEL</b>	<b>LTA460HQ12-C03</b>	<b>Doc. No</b>	<b>06-000-G-20110721</b>	<b>Page</b>	<b>26 / 28</b>
--------------	-----------------------	----------------	--------------------------	-------------	----------------

## 9.2 Storage

- (a) Do not leave the module in high temperature, and high humidity for a long time. It is highly recommended to store the module with temperature from 5 to 40 °C and relative humidity of less than 70%.
- (b) Do not store the TFT-LCD module in direct sunlight.
- (c) The module shall be stored in a dark place. It is prohibited to apply sunlight or fluorescent light during the store.
- (d) Storage condition of Packing

ITEM	UNIT	Min.	Max.
Storage Temperature	(°C)	5	40
Storage Humidity	(%rH)	35	75
Storage Life	12 months		
Storage Condition	<ul style="list-style-type: none"> <li>-Prohibit direct sunlight</li> <li>-Ventilation in storehouse and control changing temperature is within limits of environment</li> <li>-Put it on pallet and store them with removing from wall.</li> <li>-Don't wet Out-BOX and avoid rain.</li> <li>-Without condensation.</li> <li>-Etc. Avoid harmful Condition</li> </ul>		
Long-term Storage Process	<ul style="list-style-type: none"> <li>-More than 3 months Storage or Low temp. Delivery/under 5°C storage</li> <li>→On the 20°C,50%rH Condition, more than 10hr release.</li> </ul>		

## 9.3 Operation

- (a) Do not connect or disconnect the Module in the "Power On" condition.
- (b) Power supply should always be turned on/off by the "Power on/off sequence"
- (c) Module has high frequency circuits. Sufficient suppression to the electromagnetic interference should be done by system manufacturers. Grounding and shielding methods may be important to minimize the interference.
- (d) The cable between the back light connector and its converter power supply should be connected directly with a minimized length. A longer cable between the back light and the converter may cause lower luminance of lamp(LED) and may require higher startup voltage(Vs).

MODEL	LTA460HQ12-C03	Doc. No	06-000-G-20110721	Page	27 / 28
-------	----------------	---------	-------------------	------	---------

## 9.4 Operation Condition Guide

(a) The LCD product should be operated under normal conditions.

Normal condition is defined as below;

- Temperature :  $20 \pm 15^{\circ}\text{C}$
- Humidity :  $55 \pm 20\%$
- Display pattern : continually changing pattern (Not stationary)

(b) If the product will be used in extreme conditions such as high temperature, humidity, display patterns or operation time etc., It is strongly recommended to contact SEC for Application engineering advice. Otherwise, its reliability and function may not be guaranteed. Extreme conditions are commonly found at Airports, Transit Stations, Banks, Stock market, and Controlling systems.

## 9.5 Others

(a) Ultra-violet ray filter is necessary for outdoor operation.

(b) Avoid condensation of water. It may result in improper operation or disconnection of electrode.

(c) Do not exceed the absolute maximum rating value. ( supply voltage variation, input voltage variation, variation in part contents and environmental temperature, and so on)  
Otherwise the Module may be damaged.

(d) If the Module keeps displaying the same pattern for a long period of time, the image may be "sticked" to the screen.  
To avoid image sticking, it is recommended to use a screen saver.

(e) This Module has its circuitry PCB's on the rear side and should be handled carefully in order not to be stressed.

(f) Please contact SEC in advance when you display the same pattern for a long time.

MODEL	LTA460HQ12-C03	Doc. No	06-000-G-20110721	Page	28 / 28
-------	----------------	---------	-------------------	------	---------