



## Product Information

Customer :Fukoer

DATE :5. Aug .2008

**SAMSUNG TFT-LCD****MODEL : LTA520HB10**

NOTE :

Customer's Approval

SIGNATURE

DATE

APPROVED BY

*Kyunghwan Ko*

DATE

5. Aug .2008

PREPARED BY

*Jinsu Jung*

DATE

5. Aug .2008

LCD Business

Samsung Electronics Co . , LTD.

MODEL

LTA520HB10

Doc. No

06-000-G-080805

Page

1 / 28

**\* Revision History**

Date	Rev. No	Page	Summary
Aug 5, 2008	000	all	First issued

www.panelook.com

MODEL

LTA520HB10

Doc. No

06-000-G-080805

Page

3 / 28

## 1. Absolute Maximum Ratings

If the condition exceeds maximum ratings, it can cause malfunction or unrecoverable damage to the device.

Item	Symbol	Min.	Max.	Unit	Note	
Power Supply Voltage	$V_{DD}$	$V_{DD} - 1.2$	13.2	V	(1)	
Storage temperature	$T_{STG}$	-20	60	°C	(2)	
Glass surface temperature (Operation)	Center	$T_{OPR}$	0	50	°C	(2),(5)
	T. Uniformity	$\Delta T$	-	10	°C	
Shock ( non - operating )	$S_{nop}$	-	30	G	(3)	
Vibration ( non - operating )	$V_{nop}$	-	1.5	G	(4)	

Note (1)  $T_a = 25 \pm 2$  °C

(2) Temperature and relative humidity range are shown in the figure below.

a. 90 % RH Max. ( $T_a \leq 39$  °C)

b. Relative Humidity is 90% or less. ( $T_a > 39$  °C)

c. No condensation

(3) 11ms, sine wave, one time for  $\pm X$ ,  $\pm Y$ ,  $\pm Z$  axis

(4) 10-300 Hz, Sweep rate 10min, 30min for X,Y,Z axis

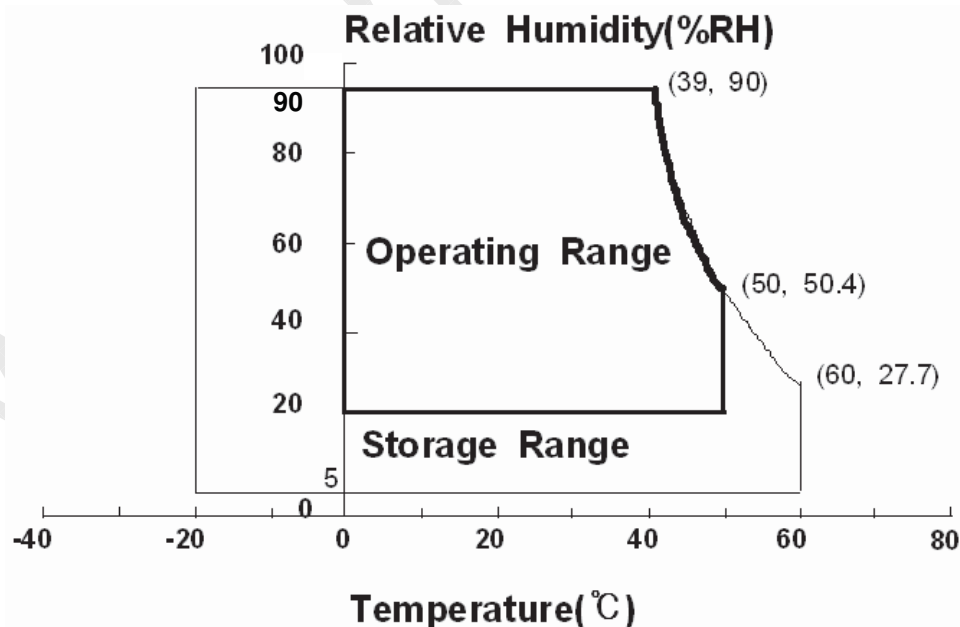

Fig. Temperature and Relative humidity range

## 2. Optical Characteristics

The optical characteristics should be measured in a dark room or equivalent.

Measuring equipment : TOPCON RD-80S, TOPCON SR-3 ,ELDIM EZ-Contrast

(Ta = 25 ± 2°C, VDD=12.0V, fv= 60Hz, f<sub>DCLK</sub>=148.5 MHz, IL = 6.5 mArms (Hot) )

Item	Symbol	Condition	Min.	Typ.	Max.	Unit	Note	
Contrast Ratio (Center of screen)	C/R	Normal $\theta_{L,R}=0$ $\theta_{U,D}=0$  Viewing Angle	2300	3000	-		(1) SR-3	
Response Time	Rising		Tr	-	14	24	msec	(3) RD-80S
	Falling		Tf	-	6	8		
	G to G		Tg	-	8	10		
Luminance of White (Center of screen)	Y <sub>L</sub>			400	500	-	cd/m <sup>2</sup>	(4) SR-3
Color Chromaticity (CIE 1931)	Red		Rx	TYP. -0.03	0.641	TYP. +0.03		(5),(6) SR-3
			Ry		0.336			
	Green		Gx		0.286			
			Gy		0.610			
	Blue		Bx		0.146			
		By	0.061					
	White	Wx	0.280					
		Wy	0.290					
Color Gamut	-	-	72	-	%	(5) SR-3		
Color Temperature	-	-	10000	-	K			
Viewing Angle	Hor.	$\theta_L$	75	90	-	Degree	(6) EZ-Contrast	
		$\theta_R$	75	90	-			
	Ver.	$\theta_U$	75	90	-			
		$\theta_D$	75	90	-			
Brightness Uniformity (9 Points)	B <sub>uni</sub>		-	-	25	%	(2) SR-3	

### - Test Equipment Setup

The measurement should be executed in a stable, windless and dark room between 40min and 60min after lighting the back light at the given temperature for stabilization of the back light. This should be measured in the center of screen.

f<sub>DCLK</sub>=148.5MHz

Environment condition : Ta = 25 ± 2 °C

MODEL

LTA520HB10

Doc. No

06-000-G-080805

Page

7 / 28

Note (2) Definition of 9 points brightness uniformity (Test pattern : Full White)

$$Buni = 100 * \frac{(B_{max} - B_{min})}{B_{max}}$$

Bmax : Maximum brightness

Bmin : Minimum brightness

Note (3) Definition of Response time : Sum of Tr, Tf

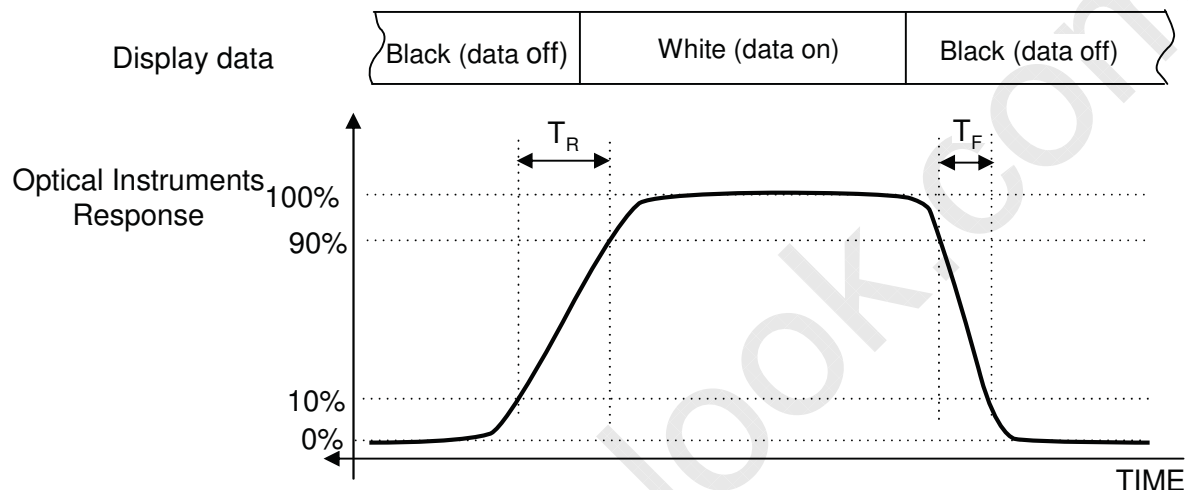

※ G-to-G : Average response time between Gray to Gray (Scale)

Note (4) Definition of Luminance of White : Luminance of white at center point ⑤

Note (5) Definition of Color Chromaticity (CIE 1931)

Color coordinate of Red, Green, Blue & White at center point ⑤

Note (6) Definition of Viewing Angle

: Viewing angle range ( $C/R \geq 10$ )

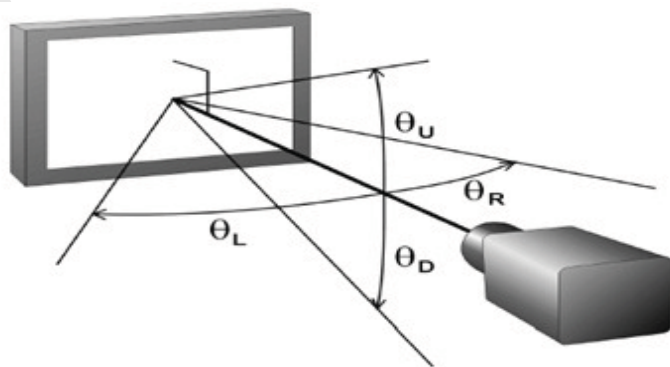

### 3.2 Back Light Unit

The back light unit contains 20 direct-lighting type CCFLs ( Cold Cathode Fluorescent Lamp ). The characteristics of lamps are shown in the following tables.

Ta=25 ± 2°C

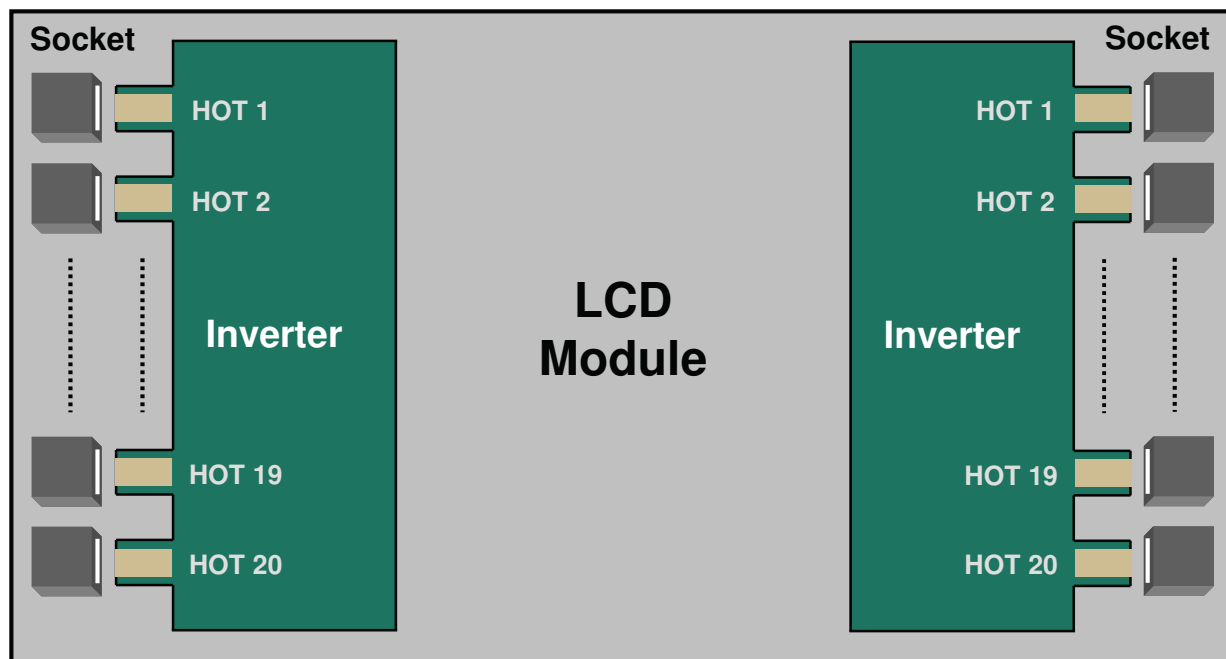

Item	Symbol	Min.	Typ.	Max.	Unit	Note
Operating Life Time	Hr	50,000	-	-	Hour	(1)

Note (1) It is defined as the time to take until the brightness reduces to 50% of its original value.

[Operating condition : Ta = 25±2°C, I<sub>L</sub> =TBD mA/Arms, For single lamp only. ]

MODEL	LTA520HB10	Doc. No	06-000-G-080805	Page	11 / 28
-------	------------	---------	-----------------	------	---------

### 4. Block Diagram

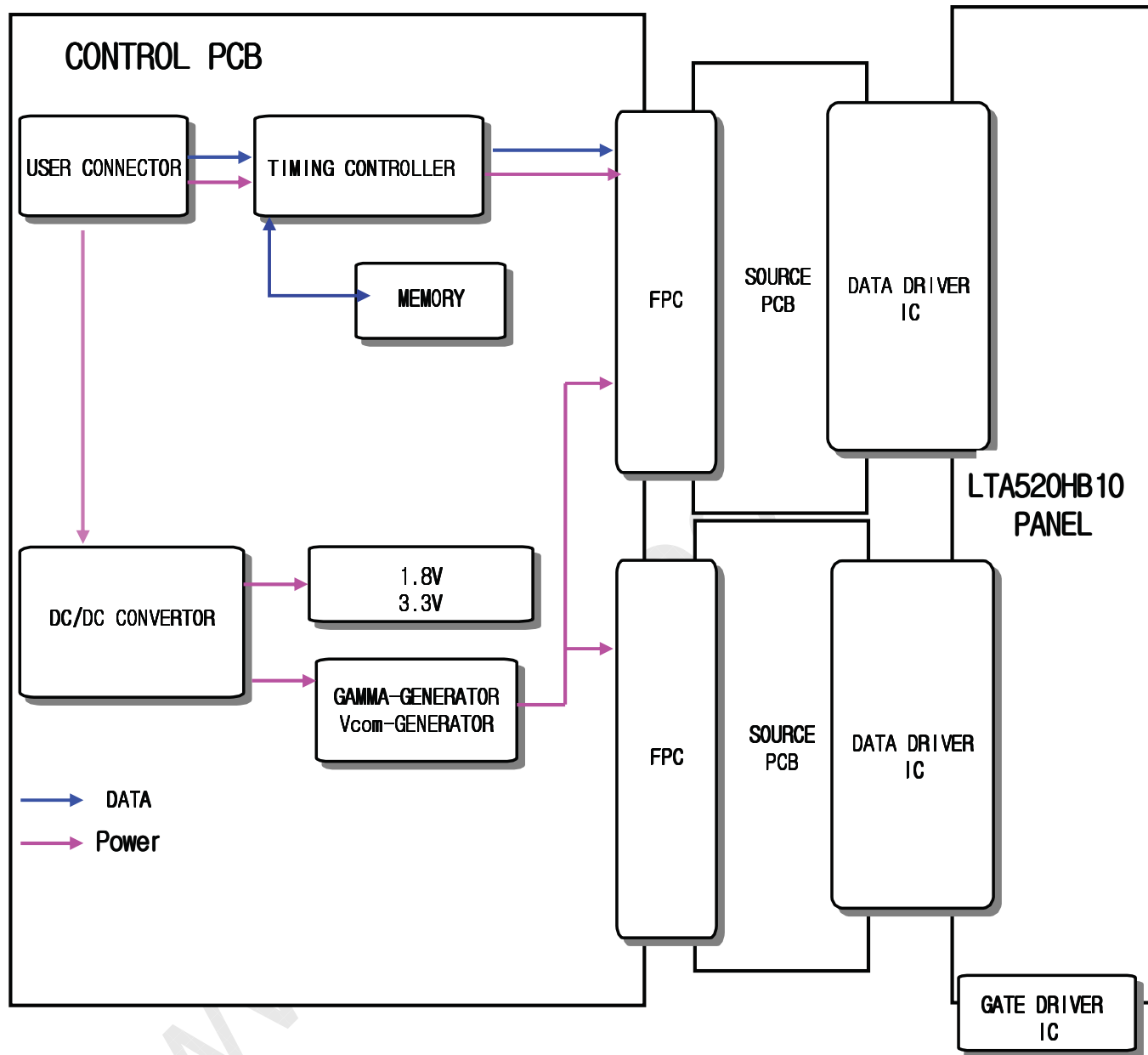

MODEL	LTA520HB10	Doc. No	06-000-G-080805	Page	13 / 28
-------	------------	---------	-----------------	------	---------

**Note1) No Connection:** This PINS are only used for SAMSUNG internal using.

**Note2-1) 10bit input :**No.22:RO[4]N Odd LVDS Signal-  
 No.23:RO[4]P Odd LVDS Signal+  
 No.37:RO[4]N Even LVDS Signal-  
 No.38:RO[4]P Even LVDS Signal+

**Note2-2) 8bit input**  
**NO.22/No37:Pull up**

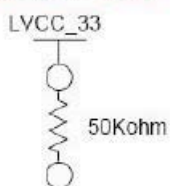

**No.23/No.38:Pull Down**

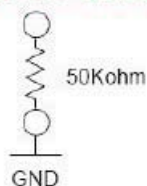

SEQUENCE : On = VDD(T1) ≥ LVDS Option ≥ Interface Signal(T2)  
 OFF = Interface Signal(T3) ≥ LVDS Option ≥ VDD

Note(1) Pin number starts from Right side

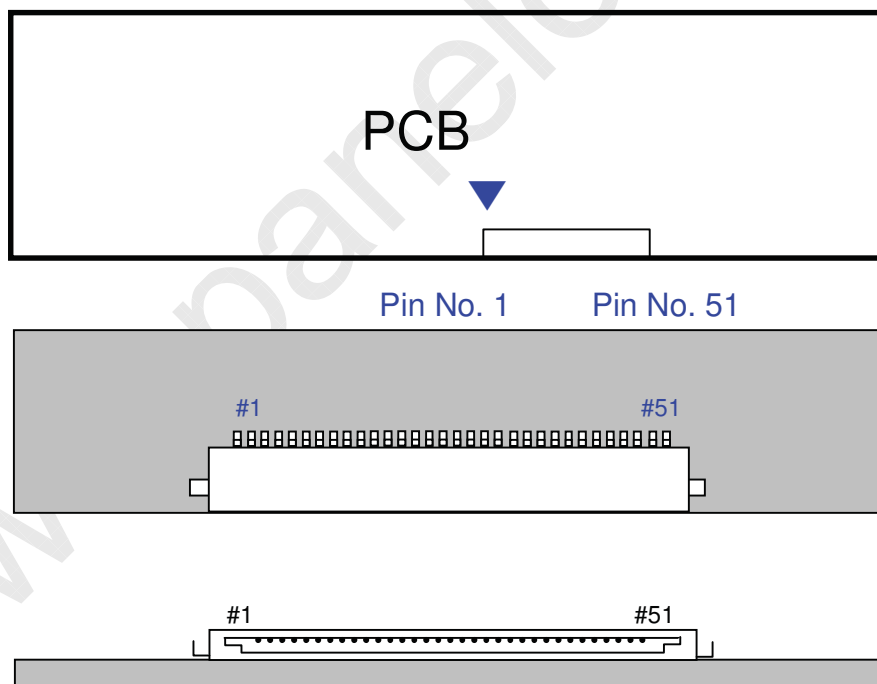

**Fig. Connector diagram**

- a. Power GND pins should be connected to the LCD's metal chassis.
- b. All power input pins should be connected together.
- c. All NC pin should be separated from other signal or power.

MODEL	LTA520HB10	Doc. No	06-000-G-080805	Page	15 / 28
-------	------------	---------	-----------------	------	---------



## 5.4 LVDS Interface

- LVDS Receiver : Tcon (merged)
- Data Format (JEIDA only)

	LVDS pin	JEIDA -DATA	
		8bit+ FRC	8bit
TxOUT/RxIN0	TxIN/RxOUT0	R4	R2
	TxIN/RxOUT1	R5	R3
	TxIN/RxOUT2	R6	R4
	TxIN/RxOUT3	R7	R5
	TxIN/RxOUT4	R8	R6
	TxIN/RxOUT6	R9	R7
	TxIN/RxOUT7	G4	G2
TxOUT/RxIN1	TxIN/RxOUT8	G5	G3
	TxIN/RxOUT9	G6	G4
	TxIN/RxOUT12	G7	G5
	TxIN/RxOUT13	G8	G6
	TxIN/RxOUT14	G9	G7
	TxIN/RxOUT15	B4	B2
	TxIN/RxOUT18	B5	B3
TxOUT/RxIN2	TxIN/RxOUT19	B6	B4
	TxIN/RxOUT20	B7	B5
	TxIN/RxOUT21	B8	B6
	TxIN/RxOUT22	B9	B7
	TxIN/RxOUT24	HSYNC	HSYNC
	TxIN/RxOUT25	VSYNC	VSYNC
	TxIN/RxOUT26	DEN	DEN
TxOUT/RxIN3	TxIN/RxOUT27	R2	R0
	TxIN/RxOUT5	R3	R1
	TxIN/RxOUT10	G2	G0
	TxIN/RxOUT11	G3	G1
	TxIN/RxOUT16	B2	B0
	TxIN/RxOUT17	B3	B1
	TxIN/RxOUT23	RESERVED	RESERVED
TxOUT/RxIN4	TxIN/RxOUT28	R0	Pull-UP or Pull Down
	TxIN/RxOUT29	R1	
	TxIN/RxOUT30	G0	
	TxIN/RxOUT31	G1	
	TxIN/RxOUT32	B0	
	TxIN/RxOUT33	B1	
	TxIN/RxOUT34	RESERVED	

MODEL

LTA520HB10

Doc. No

06-000-G-080805

Page

17 / 28

## 6. Interface Timing

### 6.1 Timing Parameters ( DE only mode )

SIGNAL	ITEM	SYMBOL	MIN.	TYP.	MAX.	Unit	NOTE
Clock	Frequency	$1/T_C$	130	148.5	155	MHz	-
Hsync		$F_H$	50	67.5	75	KHz	-
Vsync		$F_V$	48	60	62	Hz	-
Vertical Display Term	Active Display Period	$T_{VD}$	-	1080	-	Lines	-
	Vertical Total	$T_V$	1100	1125	1480	Lines	-
Horizontal Display Term	Active Display Period	$T_{HD}$	-	1920	-	Clocks	-
	Horizontal Total	$T_H$	2050	2200	2350	clocks	-

Note) This product is DE only mode. The input of Hsync & Vsync signal does not have an effect on normal operation.

- (1) Test Point : TTL control signal and CLK at LVDS Tx input terminal in system
- (2) Internal  $V_{DD} = 3.3V$

### 6.3 Power ON/OFF Sequence

To prevent a latch-up or DC operation of the LCD Module, the power on/off sequence should be as the diagram below.

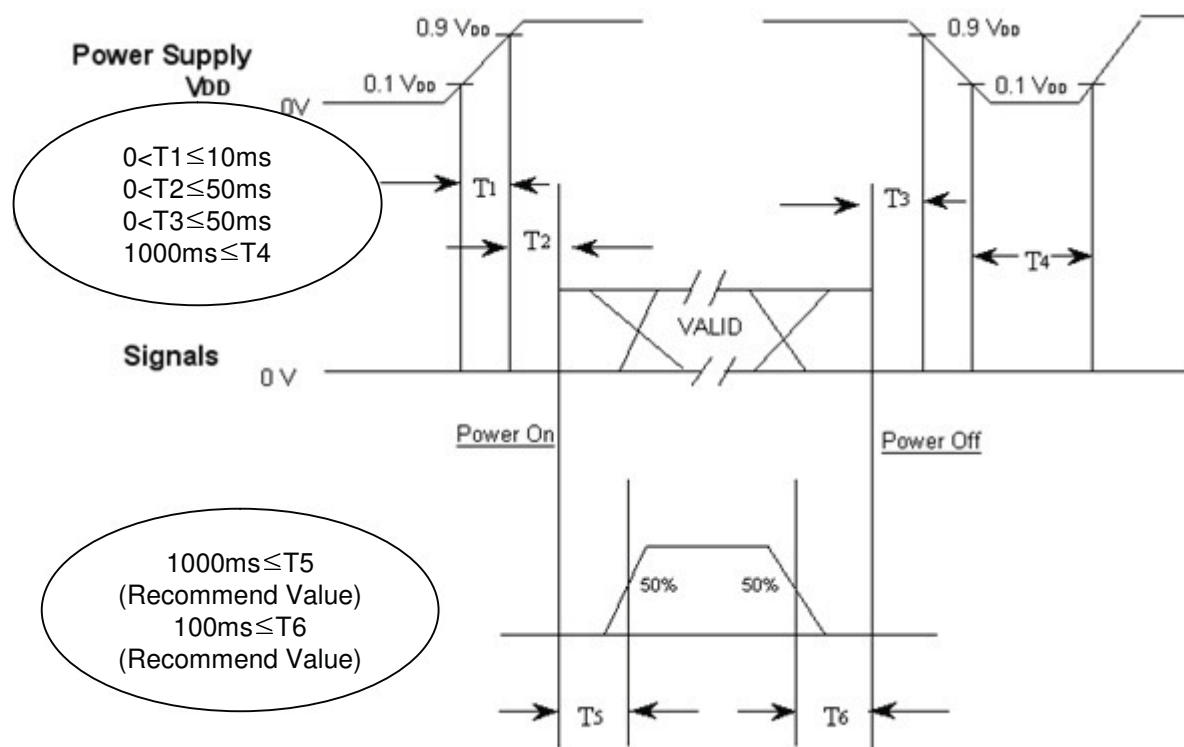

$T_1$  :  $V_{DD}$  rising time from 10% to 90%

$T_2$  : The time from  $V_{DD}$  to valid data at power ON.

$T_3$  : The time from valid data off to  $V_{DD}$  off at power Off.

$T_4$  :  $V_{DD}$  off time for Windows restart

$T_5$  : The time from valid data to B/L enable at power ON.

$T_6$  : The time from valid data off to B/L disable at power Off.

- The supply voltage of the external system for the Module input should be the same as the definition of  $V_{DD}$ .
- Apply the lamp voltage within the LCD operation range. When the back light turns on before the LCD operation or the LCD turns off before the back light turns off, the display may momentarily show abnormal screen.
- In case of  $V_{DD}$  = off level, please keep the level of input signals low or keep a high impedance.
- $T_4$  should be measured after the Module has been fully discharged between power off and on period.
- Interface signal should not be kept at high impedance when the power is on.

MODEL

LTA520HB10

Doc. No

06-000-G-080805

Page

21 / 28



### 9. MARKING & OTHERS

A nameplate bearing followed by is affixed to a shipped product at the specified location on each product.

- (1) Part number : LTA520HB10
- (2) Revision: Three letters
- (3) Lot number : X X X X XXX XX X

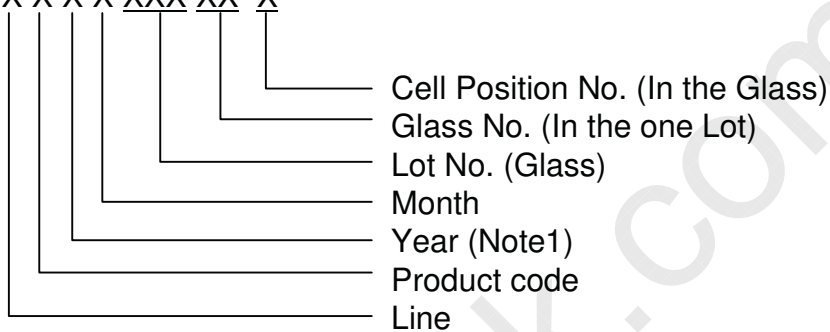

#### (4) Nameplate Indication

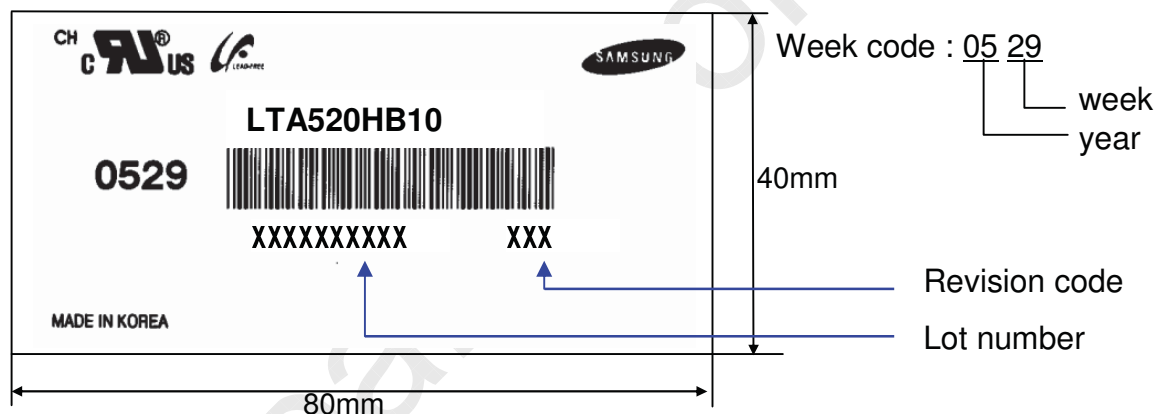

#### (5) Packing box attach

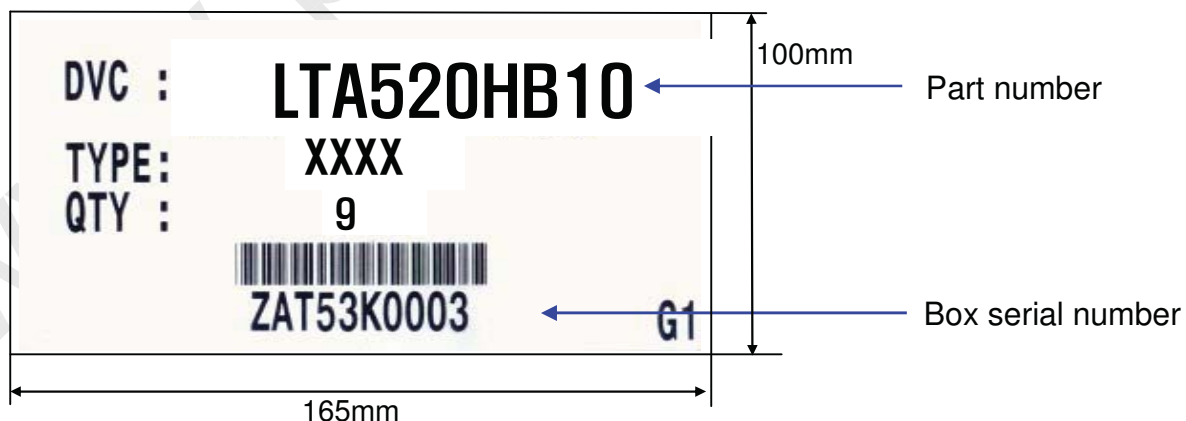

#### (6) Others

- 1. After service part  
 Lamps cannot be replaced because of the narrow bezel structure.

MODEL	LTA520HB10	Doc. No	06-000-G-080805	Page	25 / 28
-------	------------	---------	-----------------	------	---------

## 10.2 Storage

- (a) Do not leave the Module in high temperature, and high humidity for a long time. It is highly recommended to store the Module with temperature from 0 to 35 °C and relative humidity of less than 70%.
- (b) Do not store the TFT-LCD Module in direct sunlight.
- (c) The Module should be stored in a dark place. It is prohibited to apply sunlight or fluorescent light in storing.

## 10.3 Operation

- (a) Do not connect or disconnect the Module in the "Power On" condition.
- (b) Power supply should always be turned on/off by the "Power on/off sequence"
- (c) Module has high frequency circuits. Sufficient suppression to the electromagnetic interference should be done by system manufacturers. Grounding and shielding methods may be important to minimize the interference.
- (d) The cable between the back light connector and its inverter power supply should be connected directly with a minimized length. A longer cable between the back light and the inverter may cause lower luminance of lamp(CCFT) and may require higher startup voltage(Vs).

## 10.4 Operation Condition Guide

- (a) The LCD product should be operated under normal conditions.  
Normal condition is defined as below;
  - Temperature :  $20 \pm 15$  °C
  - Humidity :  $55 \pm 20$  %
  - Display pattern : continually changing pattern (Not stationary)
- (b) If the product will be used in extreme conditions such as high temperature, humidity, display patterns or operation time etc., It is strongly recommended to contact SEC for Application engineering advice. Otherwise, its reliability and function may not be guaranteed. Extreme conditions are commonly found at Airports, Transit Stations, Banks, Stock market, and Controlling systems.

MODEL	LTA520HB10	Doc. No	06-000-G-080805	Page	27 / 28
-------	------------	---------	-----------------	------	---------