



Product Information

Customer : Teco

DATE : Apr,04.2008

SAMSUNG TFT-LCD**MODEL : LTA520HE10**

The Information Described in this Specification is Preliminary and can be changed without prior notice

NOTE :

Customer's Approval		APPROVAED BY <i>Kyunghwan Ko</i>	DATE 04.Apr.2008
		PREPARED BY Yong sun KIM	DATE 04.Apr.2008
SIGNATURE	DATE		

LCD Business

Samsung Electronics Co . , LTD.

MODEL	LTA520HE10	Doc. No	06-000-G-080404	Page	1 / 29
-------	------------	---------	-----------------	------	--------

Contents

Revision History	(3)
General Description	(4)
General Information	(4)
1. Absolute Maximum Ratings	(5)
2. Optical Characteristics	(7)
3. Electrical Characteristics	(10)
3.1 TFT LCD Module	
3.2 Back Light Unit	
4. Block Diagram	(13)
5. Input Terminal Pin Assignment	(14)
5.1 Input Signal & Power	
5.2 Inverter Input Pin Configuration	
5.3 Inverter Input Power Sequence	
5.4 LVDS Interface	
5.5 Input Signals, Basic Display Colors and Gray Scale of Each Color	
6. Interface Timing	(20)
6.1 Timing Parameters (DE only mode)	
6.2 Timing Diagrams of interface Signal (DE only mode)	
6.3 Power ON/OFF Sequence	
7. Outline Dimension	(23)
8. Packing	(25)
9. Marking & Others	(26)
10. General Precaution	(27)
10.1 Handling	
10.2 Storage	
10.3 Operation	
10.4 Operation Condition Guide	
10.5 Others	

MODEL

LTA520HE10

Doc. No

06-000-G-080404

Page

2 / 29

*** Revision History**

Date	Rev. No	Page	Summary
Apr, 04, 2008	000	all	First issued

MODEL

LTA520HE10

Doc. No

06-000-G-080404

Page

3 / 29

General Description

Description

LTA520HE10 is a color active matrix liquid crystal display (LCD) that uses amorphous silicon TFT (Thin Film Transistor) as switching components. This model is composed of a TFT LCD panel, a driver circuit and a back light unit. The resolution of a 52.0" is 1920 x 1080 and this model can display up to 1.07 billion colors with wide viewing angle of 89° or higher in all directions. This panel is intended to support applications to provide an excellent performance for Flat Panel Display such as Home-alone Multimedia TFT-LCD TV and High Definition TV.

Features

- RoHS compliance (Pb-free)
- High contrast & aperture ratio
- SPVA (Super Patterned Vertical Align) mode
- Wide viewing angle ($\pm 178^\circ$)
- High speed response
- FHD resolution (16:9)
- Low Power consumption
- Direct Type 24 CCFLs (Cold Cathode Fluorescent Lamp)
- DE(Data Enable) mode
- 4ch LVDS (Low Voltage Differential Signaling) interface (4pixel/clock)

General Information

Items	Specification	Unit	Note
Module Size	1226.0(H _{TYP}) x 719.2(V _{TYP})	mm	±1.0mm
	58.5(D _{MAX})		
Weight	18,000(Max.)	g	
Pixel Pitch	0.6(H) x 0.6 (V)	mm	
Active Display Area	1152.0(H) x 648.0(V)	mm	
Surface Treatment	Haze 14% , AG(3H)	-	Anti_Glare
Display Colors	10 bit – 1.07 B	Colors	
Number of Pixels	1920 x 1080	Pixel	
Pixel Arrangement	RGB vertical stripe	-	
Display Mode	Normally Black	-	
Luminance of White	500 (Typ.)	cd/m ²	

MODEL

LTA520HE10

Doc. No

06-000-G-080404

Page

4 / 29

1. Absolute Maximum Ratings

If the condition exceeds maximum ratings, it can cause malfunction or unrecoverable damage to the device.

Item	Symbol	Min.	Max.	Unit	Note	
Power Supply Voltage	V_{DD}	$V_{DD} - 1.2$	13.2	V	(1)	
Storage temperature	T_{STG}	-20	60	°C	(2)	
Glass surface temperature (Operation)	Center	T_{OPR}	0	50	°C	(2),(5)
	T. Uniformity	ΔT	-	10	°C	
Shock (non - operating)	S_{nop}	-	30	G	(3)	
Vibration (non - operating)	V_{nop}	-	1.5	G	(4)	

Note (1) $T_a = 25 \pm 2$ °C

(2) Temperature and relative humidity range are shown in the figure below.

a. 90 % RH Max. ($T_a \leq 39$ °C)

b. Relative Humidity is 90% or less. ($T_a > 39$ °C)

c. No condensation

(3) 11ms, sine wave, one time for $\pm X$, $\pm Y$, $\pm Z$ axis

(4) 10-300 Hz, Sweep rate 10min, 30min for X,Y,Z axis

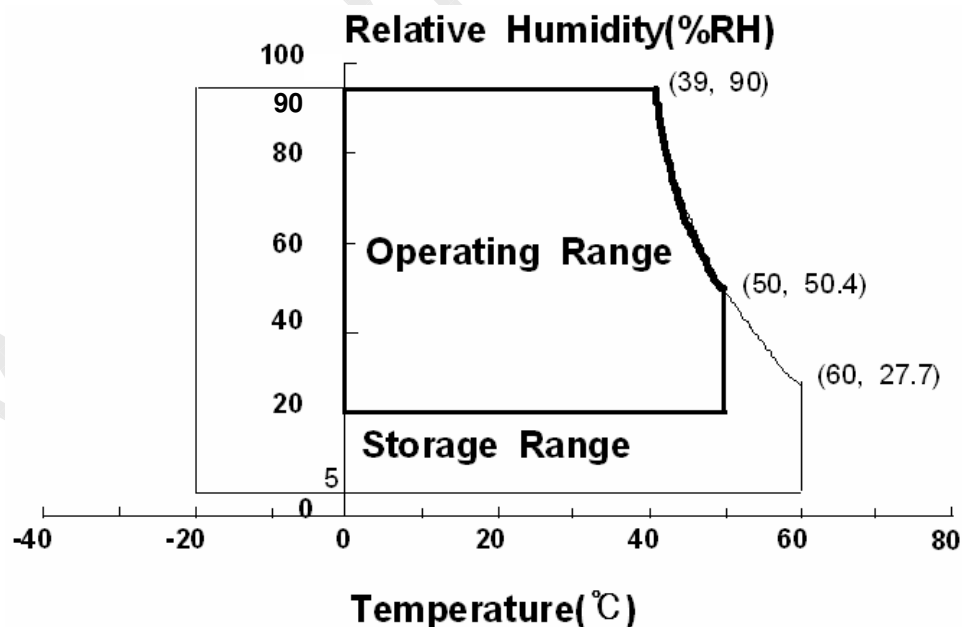
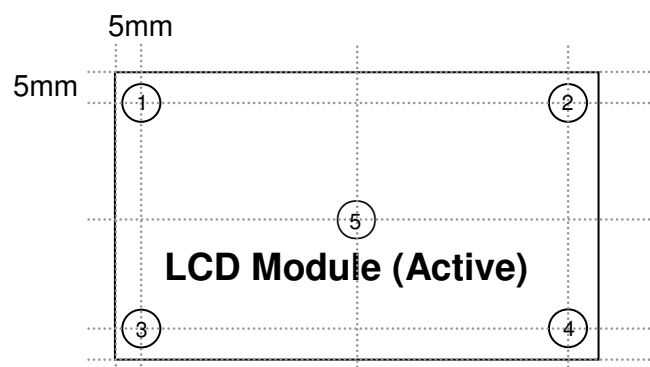

Fig. Temperature and Relative humidity range

(5) Definition of test point



ΔT should be less than $10\text{ }^{\circ}\text{C}$ ($\Delta T = |T_{\text{OPR}} - T_{\text{MAX}}|$)

T_{OPR} : Temperature of the center of the glass surface (Test point 5)

$T_1 \sim T_4$: Temperature of each edge of the glass surface

T_{MAX} : The highest temperature of the glass surface

2. Optical Characteristics

The optical characteristics should be measured in a dark room or equivalent.

Measuring equipment : TOPCON RD-80S, TOPCON SR-3 ,ELDIM EZ-Contrast

(Ta = 25 ± 2°C, VDD=12.0V, fv= 120Hz, f_{DCLK}=297 MHz)

Item	Symbol	Condition	Min.	Typ.	Max.	Unit	Note	
Contrast Ratio (Center of screen)	C/R	Normal $\theta_{L,R}=0$ $\theta_{U,D}=0$ Viewing Angle	2500	3000	-		(1) SR-3	
Response Time	Rising		Tr	-	12	20	msec	(3) RD-80S
	Falling		Tf	-	6	8		
	G to G		Tg	-	6	8		
Luminance of White (Center of screen)	Y _L			400	500	-	cd/m ²	(4) SR-3
Color Chromaticity (CIE 1931)	Red		Rx	TYP. -0.03	0.653	TYP. +0.03		(5),(6) SR-3
			Ry		0.330			
	Green		Gx		0.214			
			Gy		0.669			
	Blue		Bx		0.148			
		By	0.067					
	White	Wx	0.280					
		Wy	0.290					
Color Gamut	-	-	90	-	%	(5) SR-3		
Color Temperature	-	-	10000	-	K			
Viewing Angle	Hor.	θ_L	75	89	-	Degree	(6) EZ-Contrast	
		θ_R	75	89	-			
	Ver.	θ_U	75	89	-			
		θ_D	75	89	-			
Brightness Uniformity (9 Points)	B _{uni}		-	-	25	%	(2) SR-3	

- Test Equipment Setup

The measurement should be executed in a stable, windless and dark room between 40min and 60min after lighting the back light at the given temperature for stabilization of the back light. This should be measured in the center of screen.

Environment condition : Ta = 25 ± 2 °C

MODEL

LTA520HE10

Doc. No

06-000-G-080404

Page

7 / 29

Photo detector	Field
SR-3	1°
RD-80S	2°

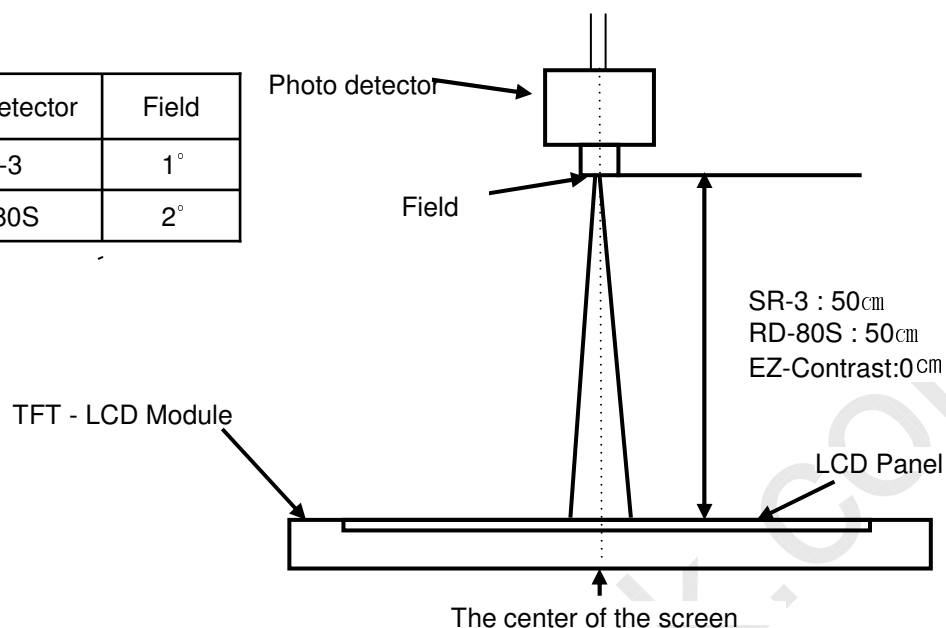

- Definition of test point

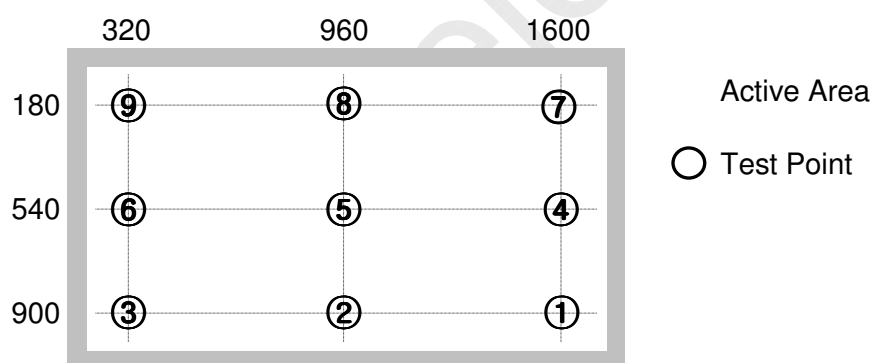

Note (1) Definition of Contrast Ratio (C/R)

: Ratio of gray max (Gmax) & gray min (Gmin) at the center point ⑤ of the panel

$$C/R = \frac{G \max}{G \min}$$

Gmax : Luminance with all pixels white

Gmin : Luminance with all pixels black

MODEL

LTA520HE10

Doc. No

06-000-G-080404

Page

8 / 29

Note (2) Definition of 9 points brightness uniformity (Test pattern : Full White)

$$Buni = 100 * \frac{(B_{max} - B_{min})}{B_{max}}$$

Bmax : Maximum brightness

Bmin : Minimum brightness

Note (3) Definition of Response time : Sum of Tr, Tf

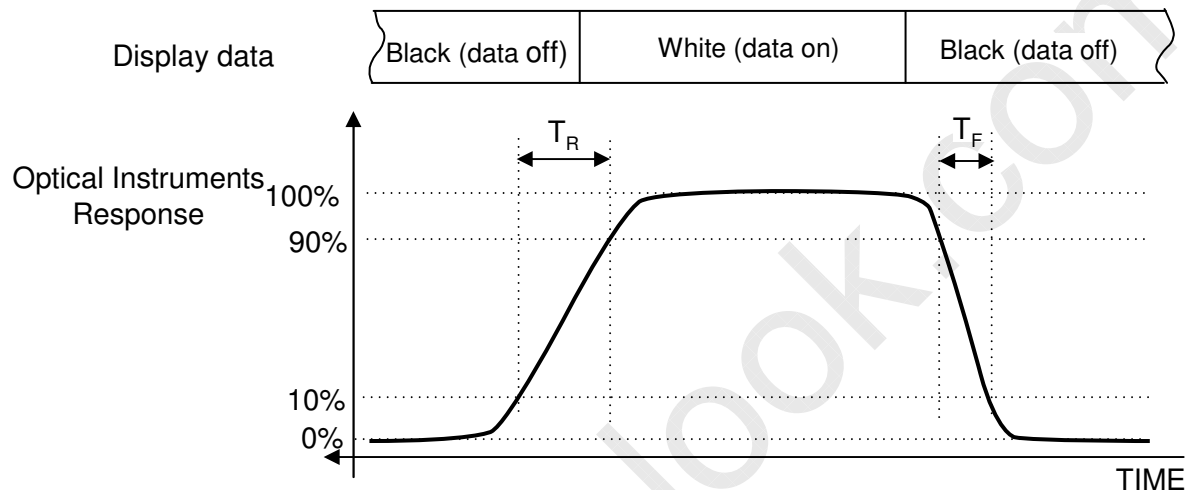

※ G-to-G : Average response time between Gray to Gray (Scale)

Note (4) Definition of Luminance of White : Luminance of white at center point ⑤

Note (5) Definition of Color Chromaticity (CIE 1931)

Color coordinate of Red, Green, Blue & White at center point ⑤

Note (6) Definition of Viewing Angle

: Viewing angle range (C/R ≥ 10)

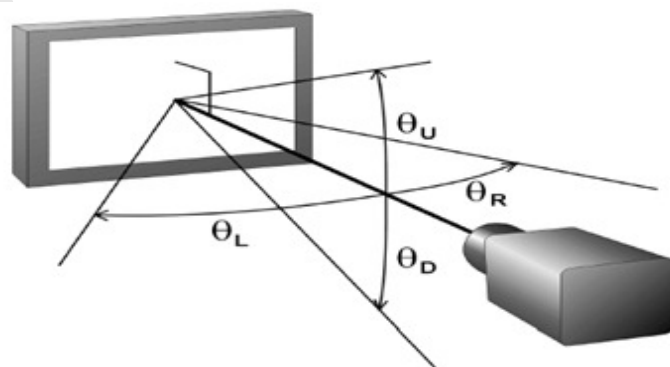

3. Electrical Characteristics

3.1 TFT LCD Module

The connector for display data & timing signal should be connected.

$T_a = 25^\circ\text{C} \pm 2^\circ\text{C}$

Item	Symbol	Min.	Typ.	Max.	Unit	Note
Voltage of Power Supply	V_{DD}	10.8	12.0	13.2	V	(1)
Current of Power Supply	(a) Black	-	1100	-	mA	(2),(3)
	(b) White	-	1200	1350	mA	
	(c) Checker	-	2320	2550	mA	
Vsync Frequency	f_V	95	120	125	Hz	
Hsync Frequency	f_H	120	132	140	kHz	
Main Frequency	Fdclk	270	297	307	MHz	
Rush Current	I_{RUSH}	-	-	7	A	(4)

Note (1) The ripple voltage should be controlled under 10% of V_{DD} .

(2) $f_V=120\text{Hz}$, $f_{DCLK} = 297\text{MHz}$, $V_{DD} = 12.0\text{V}$, DC Current.

(3) Power dissipation check pattern (LCD Module only)

a) Black Pattern

b) White

c) Checker

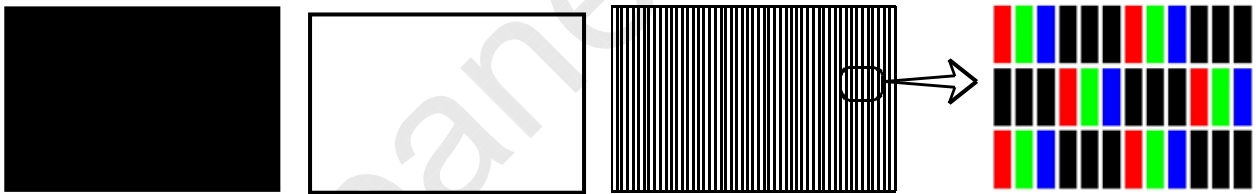

(4) Measurement Conditions

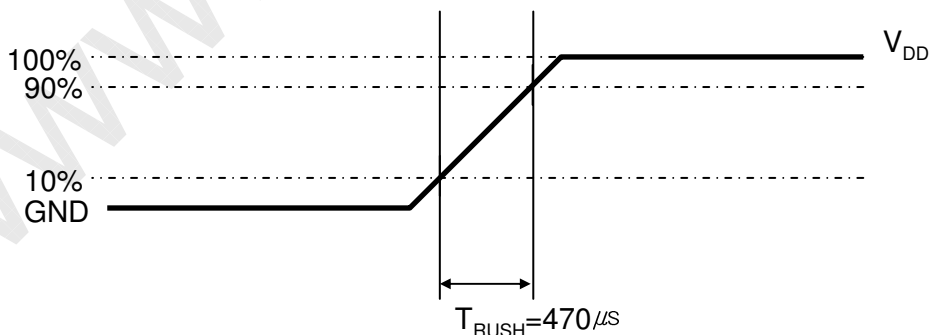

Rush Current I_{RUSH} can be measured when T_{RUSH} is $470\mu\text{s}$.

MODEL

LTA520HE10

Doc. No

06-000-G-080404

Page

10 / 29

3.2 Back Light Unit

The back light unit contains 24 direct-lighting type CCFLs (Cold Cathode Fluorescent Lamp). The characteristics of lamps are shown in the following tables.

$T_a = 25 \pm 2^\circ\text{C}$

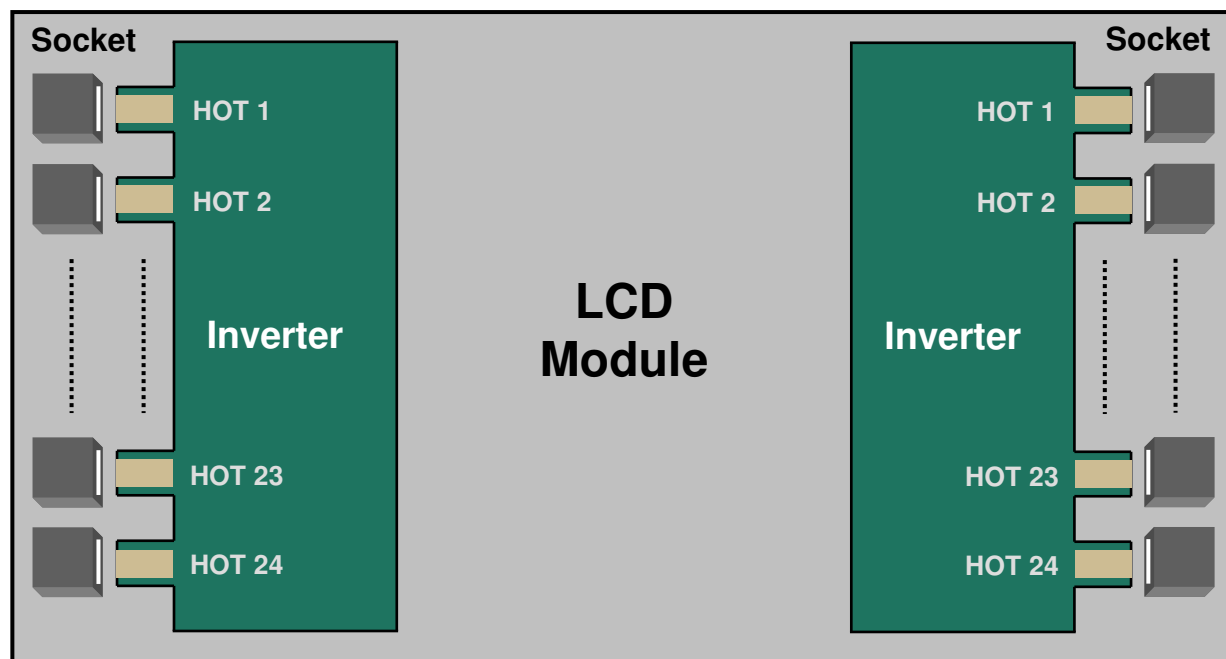

Item	Symbol	Min.	Typ.	Max.	Unit	Note
Operating Life Time	Hr	30,000	-	-	Hour	(1)

Note (1) It is defined as the time to take until the brightness reduces to 50% of its original value.

[Operating condition : $T_a = 25 \pm 2^\circ\text{C}$, $I_L = 6.0 \text{ mArms}$, For single lamp only.]

3.3 Inverter Input Condition & Specification

Items	Symbol	Conditions	Specifications			Unit	Note
			Min.	Typ.	Max.		
Input Voltage	V _{in}	-	22	24	26	V	Ta=25±2 °C
Input Current	I _{RUSH}	V _{in} =24.0V V _{dim} =3.3V	-	-	11.2	A	After 1 hour Warm-up (1)
Lamp Current	I _o	V _{in} = 24V V _{dim} = 3.3V	5.3	6.0	6.7	mArms	
Frequency	F _{LAMP}	V _{in} = 24V	40	42	44	kHz	-
Backlight On/Off	ON	V _{in} = 24V	2.4	-	5.5	V	-
	OFF	V _{in} = 24V	0	-	0.8		
Dimming Control	V _{DIM}	Max Lum	-	-	3.3	V	-
		Min. Lum	-	-	0		

Note (1) Power Consumption is measured at 500[cd/m²] of luminance condition which is the typical luminance value. Lamp Current is measured at the point before Lamp.

MODEL

LTA520HE10

Doc. No

06-000-G-080404

Page

12 / 29

4. Block Diagram

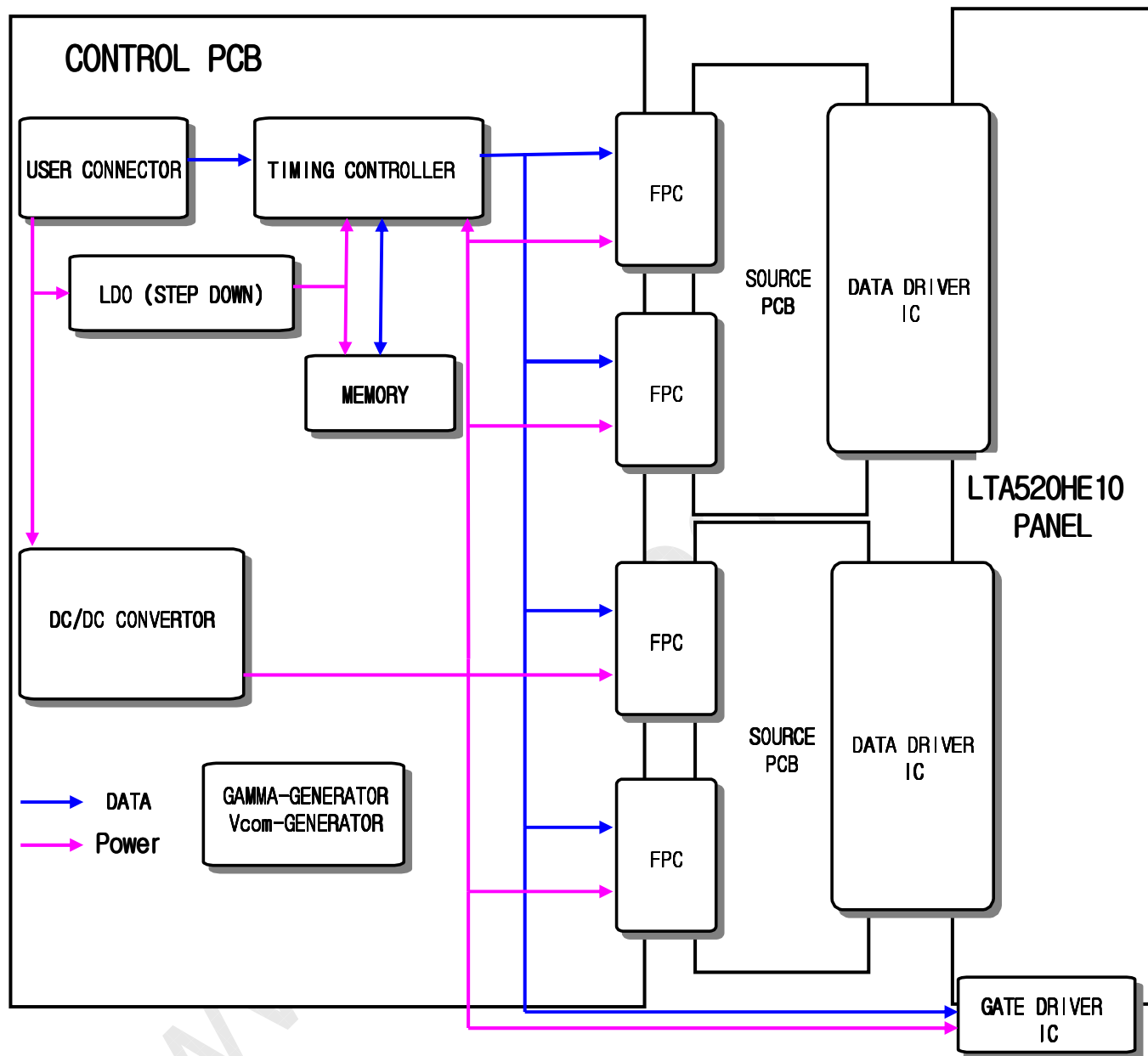

MODEL

LTA520HE10

Doc. No

06-000-G-080404

Page

13 / 29

5. Input Terminal Pin Assignment

5.1.1 Input Signal & Power

Connector① : IS050-C41B-C38 (UJU)

Pin	Description		Pin	Symbol	Description
1	Vdd(12V)		21	ODD LVDS SIGNAL	Rx1[3]P
2	Vdd(12V)		22		Rx1[4]N
3	Vdd(12V)		23		Rx1[4]P
4	Vdd(12V)		24		GND
5	Vdd(12V)		25		Rx3[0]N
6	GND		26		Rx3[0]P
7	GND		27		Rx3[1]N
8	GND		28		Rx3[1]P
9	GND		29		Rx3[2]N
10	ODD LVDS SIGNAL	Rx1[0]N	30		Rx3[2]P
11		Rx1[0]P	31		GND
12		Rx1[1]N	32		Rx3CLK-
13		Rx1[1]P	33		Rx3CLK+
14		Rx1[2]N	34		GND
15		Rx1[2]P	35		Rx3[3]N
16		GND	36		Rx3[3]P
17		Rx1CLK-	37		Rx3[4]N
18		Rx1CLK+	38		Rx3[4]P
19		GND	39		GND
20	Rx1[3]N	40	No Connection		
		41	No Connection		

MODEL

LTA520HE10

Doc. No

06-000-G-080404

Page

14 / 29

5.1.2 Input Signal & Power

Connector ② : FI-RE51S-HF (JAE)

Pin	Description	Pin	Description
1	Vdd(12V)	26	Rx4[0]P
2	Vdd(12V)	27	Rx4[1]N
3	Vdd(12V)	28	Rx4[1]P
4	Vdd(12V)	29	Rx4[2]N
5	Vdd(12V)	30	Rx4[2]P
6	GND	31	GND
7	GND	32	Rx4CLK-
8	GND	33	Rx4CLK+
9	GND	34	GND
10	Rx2[0]N	35	Rx4[3]N
11	Rx2[0]P	36	Rx4[3]P
12	Rx2[1]N	37	Rx4[4]N
13	Rx2[1]P	38	Rx4[4]P
14	Rx2[2]N	39	GND
15	Rx2[2]P	40	No Connection
16	GND	41	No Connection
17	Rx2CLK-	42	No Connection
18	Rx2CLK+	43	No Connection
19	GND	44	No Connection
20	Rx2[3]N	45	LVDS Option * Note1
21	Rx2[3]P	46	No Connection
22	Rx2[4]N	47	No Connection
23	Rx2[4]P	48	No Connection
24	GND	49	No Connection
25	Rx4[0]N	50	No Connection
		51	No Connection

(NOTE1) No connection : This Pins are only used for SAMSUNG internal using

(1) LVDS OPTION : If this PIN HIGH (3.3V) → Normal LVDS format
LOW (GND or N.C) → JEIDA LVDS format

SEQUECE : ON = VDD(T1) ≥ LVDS Option ≥ Interface Signal(T2)

OFF = Interface Signal(T3) ≥ LVDS Option ≥ VDD

MODEL

LTA520HE10

Doc. No

06-000-G-080404

Page

15 / 29

Note) Pin number starts from Right side

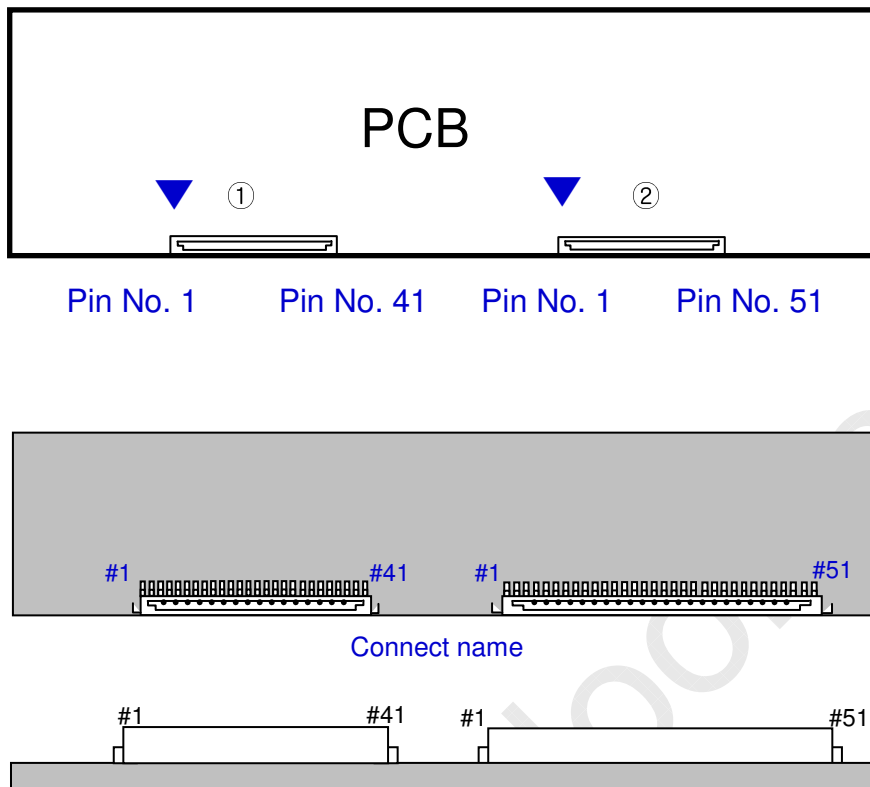

Fig. Connector diagram

- All GND pins should be connected together and also be connected to the LCD's metal chassis.
- All power input pins should be connected together.
- All NC pins should be separated from other signal or power.

5.2. Inverter Input Pin Configuration

(1) Connector (Master & Slave): S14B-PHA-SM-TB(LF) (JST)

Pin No.	Pin Configuration (FUNCTION)	
	Master (Left)	Slave (Right)
1	Vin (24 V)	24 V
2	Vin (24 V)	24 V
3	Vin (24 V)	24 V
4	Vin (24 V)	24 V
5	Vin (24 V)	24 V
6	GND	GND
7	GND	GND
8	GND	GND
9	GND	GND
10	GND	GND
11	No Connection	No Connection
12	Backlight On /Off [ON:2.4 - 5.25 V, OFF: 0 - 0.8 V]	No Connection
13	Dimming Control [0V: Min, 3.3V: Max]	No Connection
14	No Connection	No Connection

5.3. Inverter Input Power Sequence

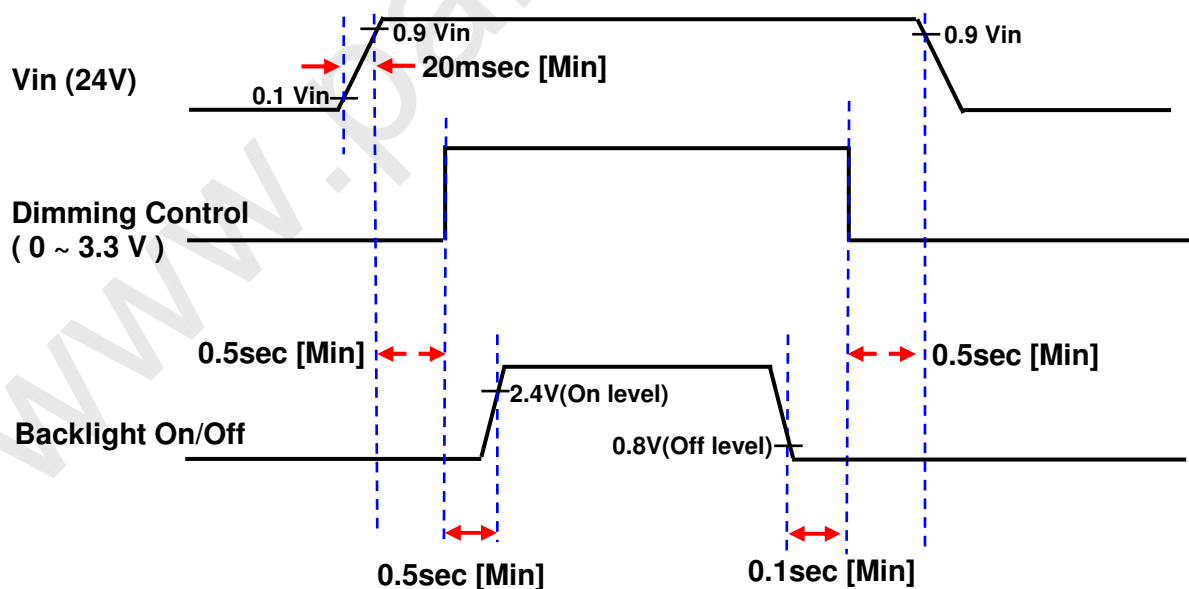

MODEL

LTA520HE10

Doc. No

06-000-G-080404

Page

17 / 29

5.4 LVDS Interface

- LVDS Receiver : Tcon (merged)
- Data Format (JEIDA only)

	LVDS pin	JEIDA
TxOUT/RxIN0	TxIN/RxOUT0	R4
	TxIN/RxOUT1	R5
	TxIN/RxOUT2	R6
	TxIN/RxOUT3	R7
	TxIN/RxOUT4	R8
	TxIN/RxOUT6	R9
	TxIN/RxOUT7	G4
TxOUT/RxIN1	TxIN/RxOUT8	G5
	TxIN/RxOUT9	G6
	TxIN/RxOUT12	G7
	TxIN/RxOUT13	G8
	TxIN/RxOUT14	G9
	TxIN/RxOUT15	B4
	TxIN/RxOUT18	B5
TxOUT/RxIN2	TxIN/RxOUT19	B6
	TxIN/RxOUT20	B7
	TxIN/RxOUT21	B8
	TxIN/RxOUT22	B9
	TxIN/RxOUT24	HSYNC
	TxIN/RxOUT25	VSYNC
	TxIN/RxOUT26	DEN
TxOUT/RxIN3	TxIN/RxOUT27	R2
	TxIN/RxOUT5	R3
	TxIN/RxOUT10	G2
	TxIN/RxOUT11	G3
	TxIN/RxOUT16	B2
	TxIN/RxOUT17	B3
	TxIN/RxOUT23	RESERVED
TxOUT/RxIN4	TxIN/RxOUT28	R0
	TxIN/RxOUT29	R1
	TxIN/RxOUT30	G0
	TxIN/RxOUT31	G1
	TxIN/RxOUT32	B0
	TxIN/RxOUT33	B1
	TxIN/RxOUT34	RESERVED

MODEL

LTA520HE10

Doc. No

06-000-G-080404

Page

18 / 29

5.5 Input Signals, Basic Display Colors and Gray Scale of Each Color

COLOR	DISPLAY	DATA SIGNAL																				GRAY SCALE LEVEL										
		RED									GREEN									BLUE												
		R0	R1	R2	R3	R4	R5	R6	R7	R8	R9	G0	G1	G2	G3	G4	G5	G6	G7	G8	G9		B0	B1	B2	B3	B4	B5	B6	B7	B8	B9
BASIC COLOR	BLACK	0	0	0	0	0	0	0	0	Q	Q	0	0	0	0	0	0	0	0	Q	Q	0	0	0	0	0	0	0	0	Q	Q	-
	BLUE	0	0	0	0	0	0	0	0	Q	Q	0	0	0	0	0	0	0	0	Q	Q	1	1	1	1	1	1	1	1	1	1	-
	GREEN	0	0	0	0	0	0	0	0	Q	Q	1	1	1	1	1	1	1	1	1	1	0	0	0	0	0	0	0	0	Q	Q	-
	CYAN	0	0	0	0	0	0	0	0	Q	Q	1	1	1	1	1	1	1	1	1	1	1	1	1	1	1	1	1	1	1	1	-
	RED	1	1	1	1	1	1	1	1	1	1	0	0	0	0	0	0	0	0	Q	Q	0	0	0	0	0	0	0	0	Q	Q	-
	MAGENTA	1	1	1	1	1	1	1	1	1	1	0	0	0	0	0	0	0	0	Q	Q	1	1	1	1	1	1	1	1	1	1	-
	YELLOW	1	1	1	1	1	1	1	1	1	1	1	1	1	1	1	1	1	1	1	1	0	0	0	0	0	0	0	0	Q	Q	-
	WHITE	1	1	1	1	1	1	1	1	1	1	1	1	1	1	1	1	1	1	1	1	1	1	1	1	1	1	1	1	1	1	-
GRAY SCALE OF RED	BLACK	0	0	0	0	0	0	0	0	Q	Q	0	0	0	0	0	0	0	0	Q	Q	0	0	0	0	0	0	0	0	Q	Q	R0
	DARK	0	0	0	0	0	0	0	0	Q	Q	0	0	0	0	0	0	0	0	Q	Q	0	0	0	0	0	0	0	0	Q	Q	R1
		0	1	0	0	0	0	0	0	Q	Q	0	0	0	0	0	0	0	0	Q	Q	0	0	0	0	0	0	0	0	Q	Q	R2
		:	:	:	:	:	:	:	:	Δ	Δ	:	:	:	:	:	:	:	:	Δ	Δ	:	:	:	:	:	:	:	:	Δ	Δ	R3~
		:	:	:	:	:	:	:	:	Δ	Δ	:	:	:	:	:	:	:	:	Δ	Δ	:	:	:	:	:	:	:	:	Δ	Δ	R1020
	LIGHT	1	0	1	1	1	1	1	1	1	1	0	0	0	0	0	0	0	0	Q	Q	0	0	0	0	0	0	0	0	Q	Q	R1021
		0	1	1	1	1	1	1	1	1	1	0	0	0	0	0	0	0	0	Q	Q	0	0	0	0	0	0	0	0	Q	Q	R1022
	RED	1	1	1	1	1	1	1	1	1	1	0	0	0	0	0	0	0	0	Q	Q	0	0	0	0	0	0	0	0	Q	Q	R1023
GRAY SCALE OF GREEN	BLACK	0	0	0	0	0	0	0	0	Q	Q	0	0	0	0	0	0	0	0	Q	Q	0	0	0	0	0	0	0	0	Q	Q	G0
	DARK	0	0	0	0	0	0	0	0	Q	Q	1	0	0	0	0	0	0	0	Q	Q	0	0	0	0	0	0	0	0	Q	Q	G1
		0	0	0	0	0	0	0	0	Q	Q	0	1	0	0	0	0	0	0	Q	Q	0	0	0	0	0	0	0	0	Q	Q	G2
		:	:	:	:	:	:	:	:	Δ	Δ	:	:	:	:	:	:	:	:	Δ	Δ	:	:	:	:	:	:	:	:	Δ	Δ	G3~
		:	:	:	:	:	:	:	:	Δ	Δ	:	:	:	:	:	:	:	:	Δ	Δ	:	:	:	:	:	:	:	:	Δ	Δ	G1020
	LIGHT	0	0	0	0	0	0	0	0	Q	Q	1	0	1	1	1	1	1	1	1	1	0	0	0	0	0	0	0	0	Q	Q	G1021
		0	0	0	0	0	0	0	0	Q	Q	0	1	1	1	1	1	1	1	1	1	0	0	0	0	0	0	0	0	Q	Q	G1022
	GREEN	0	0	0	0	0	0	0	0	Q	Q	1	1	1	1	1	1	1	1	1	1	0	0	0	0	0	0	0	0	Q	Q	G1023
GRAY SCALE OF BLUE	BLACK	0	0	0	0	0	0	0	0	Q	Q	0	0	0	0	0	0	0	0	Q	Q	0	0	0	0	0	0	0	0	Q	Q	B0
	DARK	0	0	0	0	0	0	0	0	Q	Q	0	0	0	0	0	0	0	0	Q	Q	1	0	0	0	0	0	0	0	Q	Q	B1
		0	0	0	0	0	0	0	0	Q	Q	0	0	0	0	0	0	0	0	Q	Q	0	1	0	0	0	0	0	0	Q	Q	B2
		:	:	:	:	:	:	:	:	Δ	Δ	:	:	:	:	:	:	:	:	Δ	Δ	:	:	:	:	:	:	:	:	Δ	Δ	B3~
		:	:	:	:	:	:	:	:	Δ	Δ	:	:	:	:	:	:	:	:	Δ	Δ	:	:	:	:	:	:	:	:	Δ	Δ	B1020
	LIGHT	0	0	0	0	0	0	0	0	Q	Q	0	0	0	0	0	0	0	0	Q	Q	1	0	1	1	1	1	1	1	1	1	B1021
		0	0	0	0	0	0	0	0	Q	Q	0	0	0	0	0	0	0	0	Q	Q	0	1	1	1	1	1	1	1	1	1	B1022
	BLUE	0	0	0	0	0	0	0	0	Q	Q	0	0	0	0	0	0	0	0	Q	Q	1	1	1	1	1	1	1	1	1	1	B1023

Note) Definition of Gray :
 Rn : Red Gray, Gn : Green Gray, Bn : Blue Gray (n = Gray level)
 Input Signal : 0 = Low level voltage, 1 = High level voltage

6. Interface Timing

6.1 Timing Parameters (DE only mode)

SIGNAL	ITEM	SYMBOL	MIN.	TYP.	MAX.	Unit	NOTE
Clock	Frequency	$1/T_C$	270	297	307	MHz	-
Hsync		F_H	120	132	140	KHz	-
Vsync		F_V	95	120	125	Hz	-
Vertical Display Term	Active Display Period	T_{VD}	-	1080	-	Lines	-
	Vertical Total	T_V	1090	1125	1380	Lines	-
Horizontal Display Term	Active Display Period	T_{HD}	-	1920	-	Clocks	-
	Horizontal Total	T_H	2090	2200	2350	clocks	-

Note) This product is DE only mode. The input of Hsync & Vsync signal does not have an effect on normal operation.

- (1) Test Point : TTL control signal and CLK at LVDS Tx input terminal in system
- (2) Internal $V_{DD} = 3.3V$

6.2 Timing diagrams of interface signal (DE only mode)

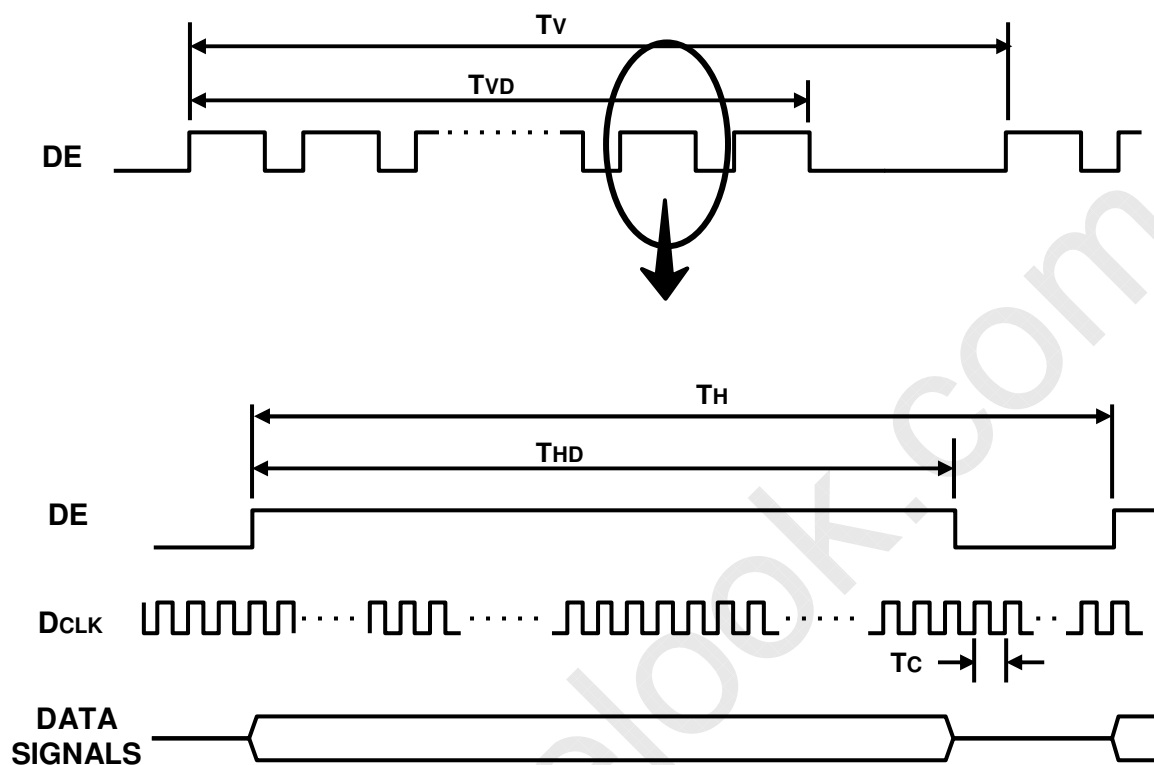

6.3 Power ON/OFF Sequence

To prevent a latch-up or DC operation of the LCD Module, the power on/off sequence should be as the diagram below.

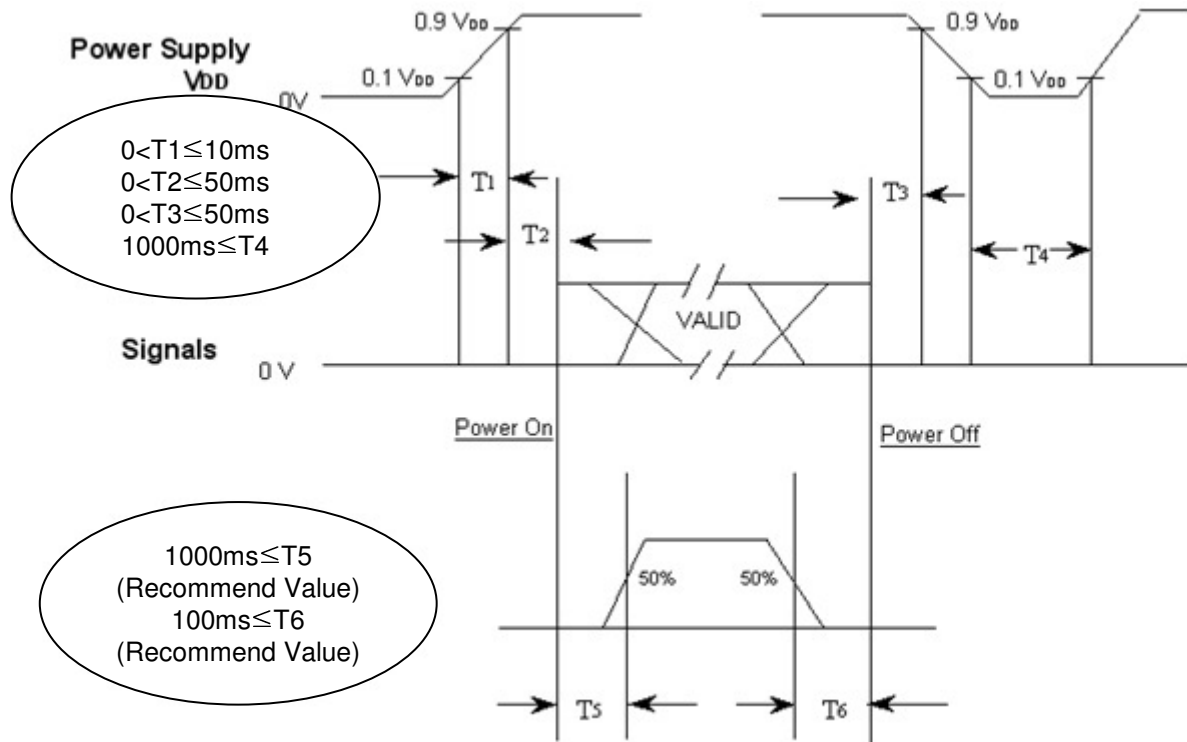

T1 : V_{DD} rising time from 10% to 90%

T2 : The time from V_{DD} to valid data at power ON.

T3 : The time from valid data off to V_{DD} off at power Off.

T4 : V_{DD} off time for Windows restart

T5 : The time from valid data to B/L enable at power ON.

T6 : The time from valid data off to B/L disable at power Off.

- The supply voltage of the external system for the Module input should be the same as the definition of V_{DD} .
- Apply the lamp voltage within the LCD operation range. When the back light turns on before the LCD operation or the LCD turns off before the back light turns off, the display may momentarily show abnormal screen.
- In case of V_{DD} = off level, please keep the level of input signals low or keep a high impedance.
- T4 should be measured after the Module has been fully discharged between power off and on period.
- Interface signal should not be kept at high impedance when the power is on.

6. Outline Dimension (Front View)

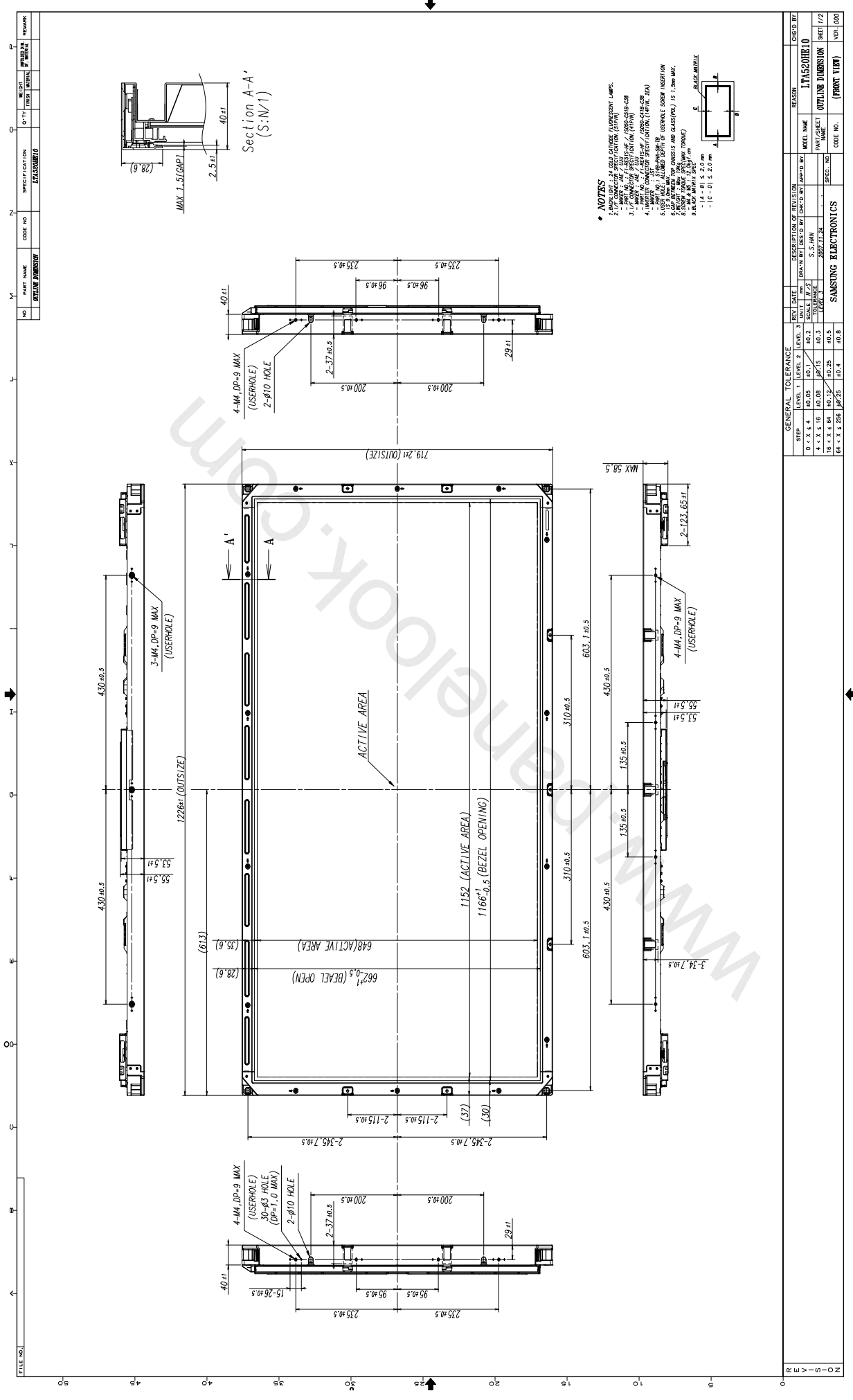

***NOTES**

1. MATERIAL: A. COLO. FILTER, FLUORESCENT LAMP.
2. MOUNTING: A. COLO. FILTER, FLUORESCENT LAMP.
3. TYPICAL DIMENSIONS: 1.5mm MAX. (UNLESS OTHERWISE SPECIFIED)
4. MOUNTING HOLE POSITION: 1.5mm MAX. (UNLESS OTHERWISE SPECIFIED)
5. MOUNTING HOLE POSITION: 1.5mm MAX. (UNLESS OTHERWISE SPECIFIED)
6. MOUNTING HOLE POSITION: 1.5mm MAX. (UNLESS OTHERWISE SPECIFIED)
7. MOUNTING HOLE POSITION: 1.5mm MAX. (UNLESS OTHERWISE SPECIFIED)
8. MOUNTING HOLE POSITION: 1.5mm MAX. (UNLESS OTHERWISE SPECIFIED)
9. MOUNTING HOLE POSITION: 1.5mm MAX. (UNLESS OTHERWISE SPECIFIED)
10. MOUNTING HOLE POSITION: 1.5mm MAX. (UNLESS OTHERWISE SPECIFIED)

STEP	GENERAL TOLERANCE	LEVEL 1	LEVEL 2	LEVEL 3	DATE	REVISION	REVISION BY	REASON	DATE	DESIGNER	DATE	DRW'N BY	DATE	CHK'D BY	DATE	CHK'D BY	DATE	CHK'D BY
0 x x x 4	±0.05	±0.1	±0.2	±0.3	2007.11.24	S. S. HAN		LTA520HE10										
4 x x x 18	±0.08	±0.15	±0.3	±0.5				OUTLINE DIMENSION										
16 x x x 64	±0.15	±0.25	±0.5	±0.8				SANSUNG ELECTRONICS										
64 x x x 256	±0.25	±0.4	±0.8	±1.0														

6. Outline Dimension (Rear View)

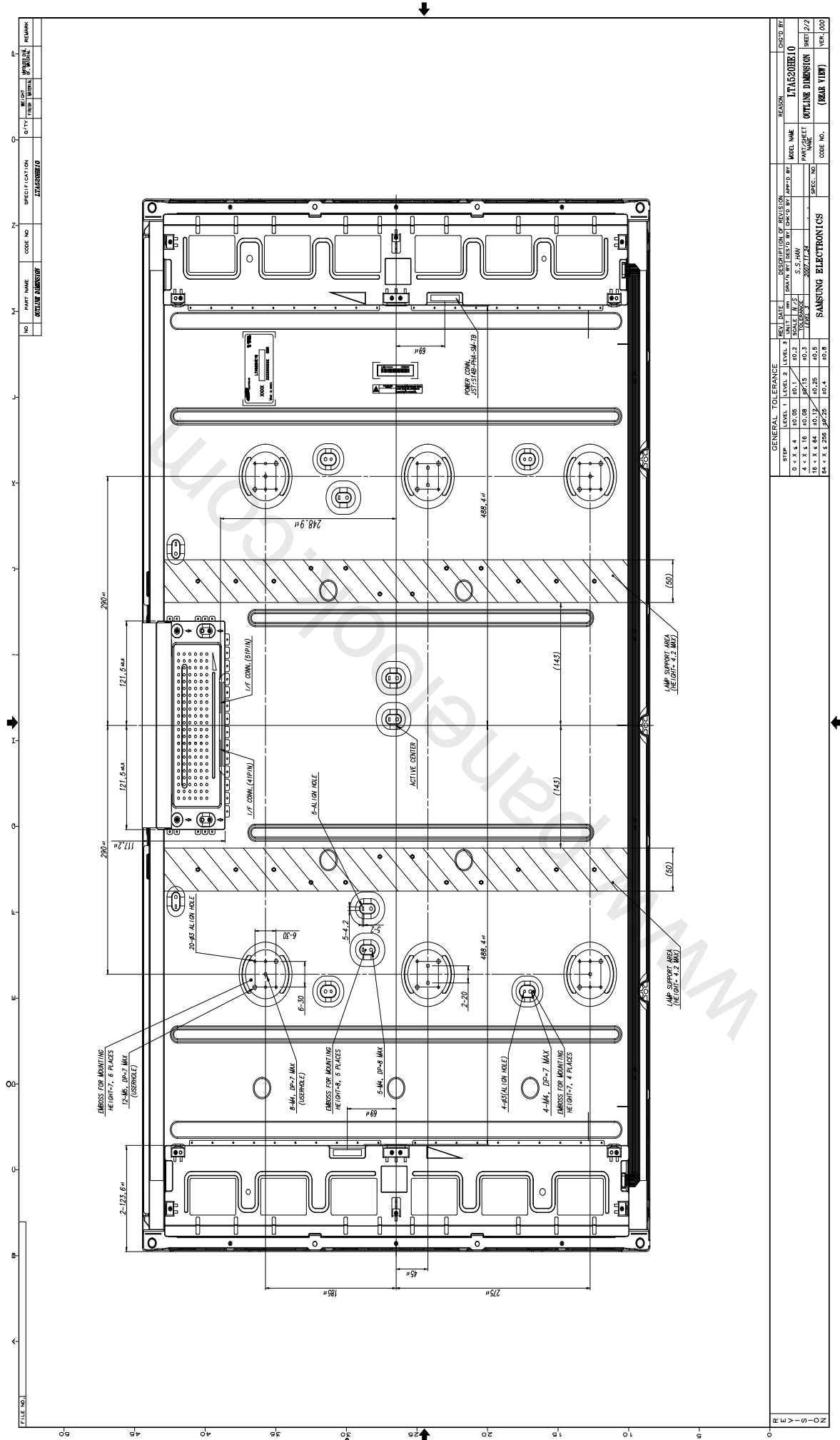

8. PACKING

8.1 CARTON (Internal Package)

(1) Packing Form

Corrugated fiberboard box and corrugated cardboard as shock absorber

(2) Packing Method

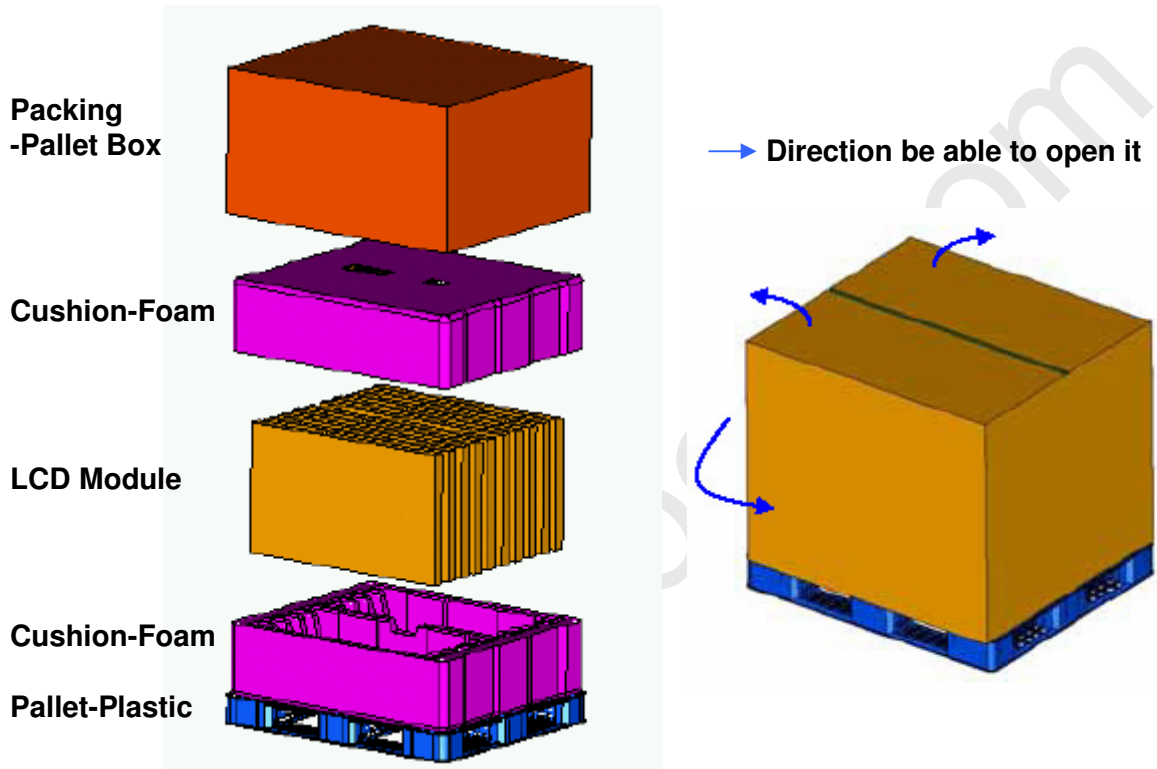

8.2 Packing Specification

Item	Specification	Remark
LCD Packing	9ea / (Packing-Pallet Box)	1. 171 Kg / LCD (9ea) 2. 15.6 Kg / Cushion-pallet (2ea) 3. 10.5 Kg / Packing-Pallet Box (1ea) 4. Cushion-pallet Material : EPS 5. Packing-Pallet Box Material : DW4
Pallet	1Box / Pallet	1. Pallet weight = 10kg
Packing Direction	Vertical	
Total Pallet Size	H x V x height	1475mm(H) x 1150mm(V) x995mm(height)
Total Pallet Weight	207.1kg	Pallet(10kg) + Module(21*9=171kg) + Cushion(up+botton=15.6kg) + Pallet-BOX(10.5kg)

MODEL

LTA520HE10

Doc. No

06-000-G-080404

Page

25 / 29

9. MARKING & OTHERS

A nameplate bearing followed by is affixed to a shipped product at the specified location on each product.

- (1) Part number : LTA520HE10
- (2) Revision: Three letters
- (3) Lot number : X X X X XXX XX X

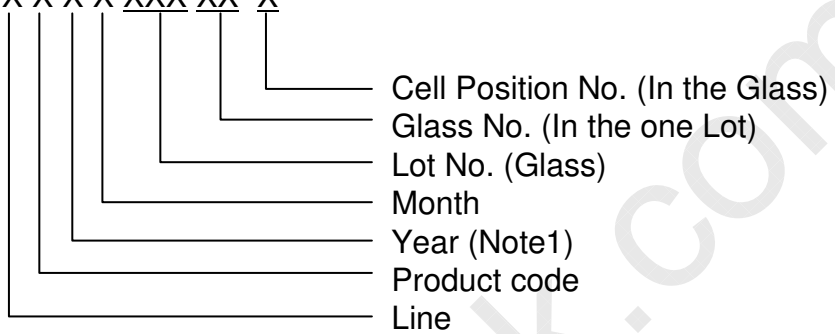

(4) Nameplate Indication

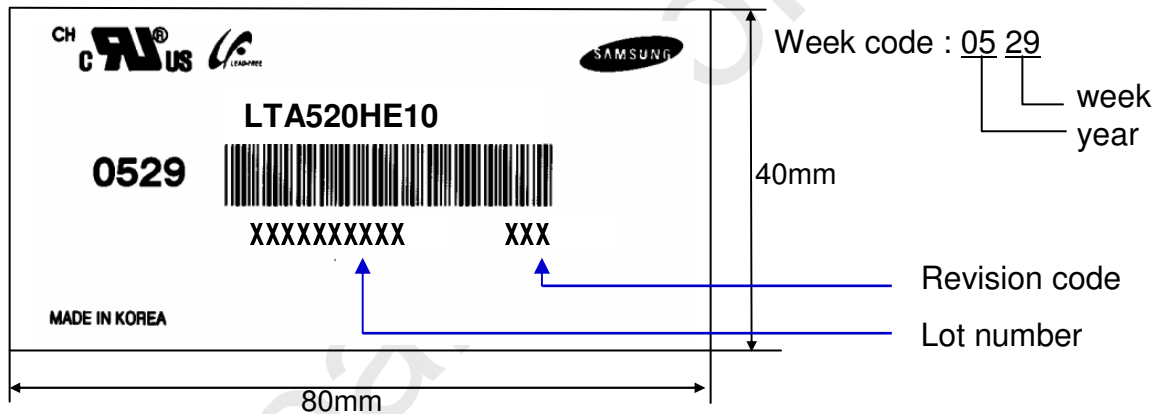

(5) Packing box attach

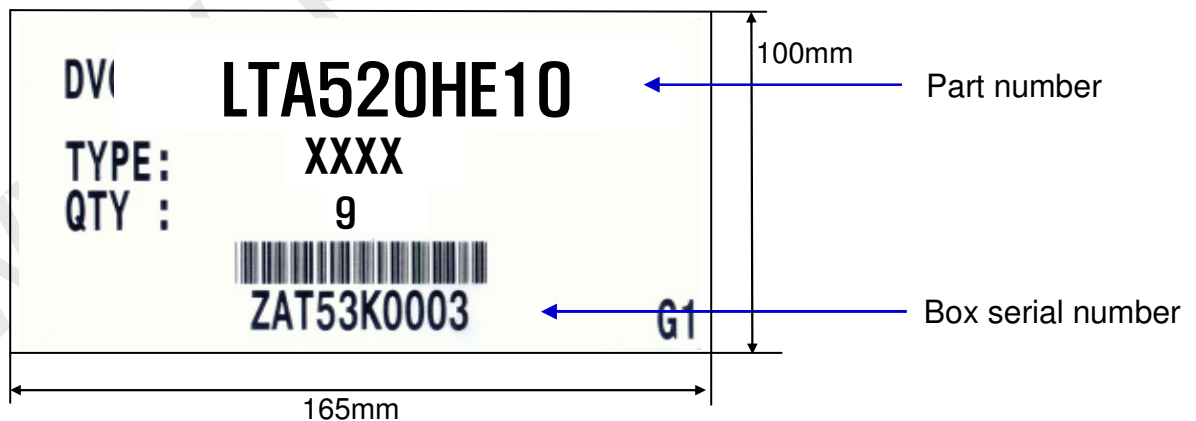

(6) Others

- 1. After service part
Lamps cannot be replaced because of the narrow bezel structure.

MODEL	LTA520HE10	Doc. No	06-000-G-080404	Page	26 / 29
-------	------------	---------	-----------------	------	---------

10. General Precautions

10.1 Handling

- (a) When the Module is assembled, it should be attached to the system firmly using all mounting holes. Be careful not to twist and bend the Module.
- (b) Because the inverter use high voltage, it should be disconnected from power before it is assembled or disassembled.
- (c) Refrain from strong mechanical shock and / or any force to the Module. In addition to damage, this may cause improper operation or damage to the Module and CCFL back light.
- (d) Note that polarizers are very fragile and could be damage easily. Do not press or scratch the surface harder than a HB pencil lead.
- (e) Wipe off water droplets or oil immediately. If you leave the droplets for a long time, staining or discoloration may occur.
- (f) If the surface of the polarizer is dirty, clean it using absorbent cotton or soft cloth.
- (g) Desirable cleaners are water, IPA(Isopropyl Alcohol) or Hexane. Do not use Ketone type materials(ex. Acetone), Ethyl alcohol, Toluene, Ethyl acid or Methyl chloride. It might permanent damage to the polarizer due to chemical reaction.
- (h) If the liquid crystal material leaks from the panel, it should be kept away from the eyes or mouth . In case of contact with hands, legs or clothes, it must be washed away with soap thoroughly.
- (i) Protect the module from Electrostatic discharge. Otherwise the ASIC IC or Semiconductor would be damaged.
- (j) Use finger-stalls with soft gloves in order to keep display clean during the incoming inspection and assembly process.
- (k) Do not disassemble the Module.
- (l) Do not disassemble shield case of inverter & LVDS board.
- (m) Do not connect N.C pins. (Samsung internal use only)
- (n) Protection film for polarizer on the Module should be slowly peeled off just before use so that the electrostatic charge can be minimized. Must put on antistatic glove while handle a module
- (o) Pins of I/F connector should not be touched directly with bare hands.

MODEL	LTA520HE10	Doc. No	06-000-G-080404	Page	27 / 29
-------	------------	---------	-----------------	------	---------

10.2 Storage

- (a) Do not leave the Module in high temperature, and high humidity for a long time. It is highly recommended to store the Module with temperature from 0 to 35 °C and relative humidity of less than 70%.
- (b) Do not store the TFT-LCD Module in direct sunlight.
- (c) The Module should be stored in a dark place. It is prohibited to apply sunlight or fluorescent light in storing.

10.3 Operation

- (a) Do not connect or disconnect the Module in the "Power On" condition.
- (b) Power supply should always be turned on/off by the "Power on/off sequence"
- (c) Module has high frequency circuits. Sufficient suppression to the electromagnetic interference should be done by system manufacturers. Grounding and shielding methods may be important to minimize the interference.
- (d) The cable between the back light connector and its inverter power supply should be connected directly with a minimized length. A longer cable between the back light and the inverter may cause lower luminance of lamp(CCFT) and may require higher startup voltage(Vs).

10.4 Operation Condition Guide

- (a) The LCD product should be operated under normal conditions.
Normal condition is defined as below;
 - Temperature : 20 ± 15 °C
 - Humidity : 55 ± 20 %
 - Display pattern : continually changing pattern (Not stationary)
- (b) If the product will be used in extreme conditions such as high temperature, humidity, display patterns or operation time etc., It is strongly recommended to contact SEC for Application engineering advice. Otherwise, its reliability and function may not be guaranteed. Extreme conditions are commonly found at Airports, Transit Stations, Banks, Stock market, and Controlling systems.

MODEL	LTA520HE10	Doc. No	06-000-G-080404	Page	28 / 29
-------	------------	---------	-----------------	------	---------

10.5 Others

- (a) Ultra-violet ray filter is necessary for outdoor operation.
- (b) Avoid condensation of water. It may result in improper operation or disconnection of electrode.
- (c) Do not exceed the absolute maximum rating value. (supply voltage variation, input voltage variation, variation in part contents and environmental temperature, and so on)
Otherwise the Module may be damaged.
- (d) If the Module keeps displaying the same pattern for a long period of time, the image may be "sticked" to the screen.
To avoid image sticking, it is recommended to use a screen saver.
- (e) This Module has its circuitry PCB's on the rear side and should be handled carefully in order not to be stressed.
- (f) Please contact SEC in advance when you display the same pattern for a long time.

MODEL

LTA520HE10

Doc. No

06-000-G-080404

Page

29 / 29