



ELECTRONICS

Approval

Customer : GA

DATE : 07.Apr.2010

**SAMSUNG TFT-LCD****MODEL : LTA550HJ06-W01**Any Modification of Specification is not allowed without SEC's Permission.

NOTE :

<b>Customer's Approval</b>	
SIGNATURE	DATE

APPROVAED BY <i>Kyunghwan Ko</i>	DATE 07.Apr.2010
PREPARED BY <b>SUNOK.SONG</b>	DATE 07.Apr.2010

LCD Business

Samsung Electronics Co . , LTD.

MODEL	LTA550HJ06	Doc. No	06-000-S-100407	Page	1/27
-------	------------	---------	-----------------	------	------

## Contents

Revision History	(3)
General Description	(4)
General Information	(4)
1. Absolute Maximum Ratings	(5)
2. Optical Characteristics	(7)
3. Electrical Characteristics	(10)
3.1 TFT LCD Module	
3.2 Back Light Unit	
3.3 Inverter Input & Specification	
4. Input Terminal Pin Assignment	(13)
4.1 Input Signal & Power	
4.2 Balance Board	
4.3 LVDS Interface	
4.4 Input Signals, Basic Display Colors and Gray Scale of Each Color	
5. Interface Timing	(19)
6.1 Timing Parameters (DE only mode)	
6.2 Power ON/OFF Sequence	
6. Outline Dimension	(22)
7. Reliability Test	(24)
8. Packing	(25)
9. Marking & Others	(26)
10. General Precaution	(27)
10.1 Handling	
10.2 Storage	
10.3 Operation	
10.4 Operation Condition Guide	
10.5 Others	

MODEL

LTA550HJ06

Doc. No

06-000-S-100407

Page

2/27



## Revision History

Date	Rev. No	Page	Summary
07.Mar .2010.	000	all	First issued

www.panelook.com

MODEL

LTA550HJ06

Doc. No

06-000-S-100407

Page

3/27

## General Description

### Description

LTA550HJ06 is a color active matrix liquid crystal display (LCD) that uses amorphous silicon TFT (Thin Film Transistor) as switching components. This model is composed of a TFT LCD panel, a driver circuit and a back light unit. The resolution of a 55.0" is 1920 x 1080 and this model can display up to 1.07 Billion colors with wide viewing angle of 89° or higher in all directions. This panel is intended to support applications to provide an excellent performance for Flat Panel Display such as Home-alone Multimedia TFT-LCD TV and High Definition TV.

### Features

- RoHS compliance (Pb-free)
- High contrast & ratio aperture ratio with wide color gamut
- SPVA (Super Patterned Vertical Align) mode
- Wide viewing angle ( $\pm 178^\circ$ )
- High speed response & Natural Motion (DFR: Double Frame Rate)
- FHD resolution (16:9)
- Low Power consumption
- 16 Normal CCFL (Cold Cathode Fluorescent Lamp)
- DE (Data Enable) mode
- LVDS (Low Voltage Differential Signaling) interface (4pixel/clock)

## General Information

Items	Specification	Unit	Note
Module Size	1267.6 (H <sub>TYP</sub> ) x 738.4 (V <sub>TYP</sub> )	mm	±1.5mm
	59.6 (D <sub>typ</sub> )		±1.2mm
Weight	16500	g	
Pixel Pitch	0.63(H) × 0.63(V)	mm	
Active Display Area	1209.6(H) X 680.4(V)	mm	
Surface Treatment	Haze 0%, Reflection ratio 1%	-	Hard -coating
Display Colors	1.07 Billion (10bit Dithering)	colors	
Number of Pixels	1920 x 1080	pixel	
Pixel Arrangement	RGB vertical stripe	-	
Display Mode	Normally Black	-	
Luminance of White	500	cd/m <sup>2</sup>	

MODEL

LTA550HJ06

Doc. No

06-000-S-100407

Page

4/27

## 1. Absolute Maximum Ratings

If the condition exceeds maximum ratings, it can cause malfunction or unrecoverable damage to the device.

(V<sub>SS</sub> = 0 V)

(V<sub>DD</sub> = 12 V)

Item	Symbol	Min.	Max.	Unit	Note	
Power Supply Voltage	V <sub>DD</sub>	10.8	13.2	V	(1)	
Storage temperature	T <sub>STG</sub>	-20	65	°C	(2)	
Glass surface temperature (Operation)	Center	T <sub>OPR</sub>	0	50	°C	(2)
	Temperature uniformity	ΔT		10	°C	(5)
Shock ( non - operating )	S <sub>nop</sub> ±X,±Y ±Z	-	30	G	(3)	
Vibration ( non - operating )	V <sub>nop</sub>	-	1.5	G	(4)	

Note (1) T<sub>a</sub> = 25 ± 2 °C

(2) Temperature and relative humidity range are shown in the figure below.

a. 90 % RH Max. (T<sub>a</sub> ≤ 39 °C)

b. Relative Humidity is 90% or less. (T<sub>a</sub> > 39 °C)

c. No condensation

(3) 11ms, sine wave, one time for ±X, ±Y, ±Z axis, 30G

(4) 10-300 Hz, Sweep rate 11min, 30min for X,Y,Z axis

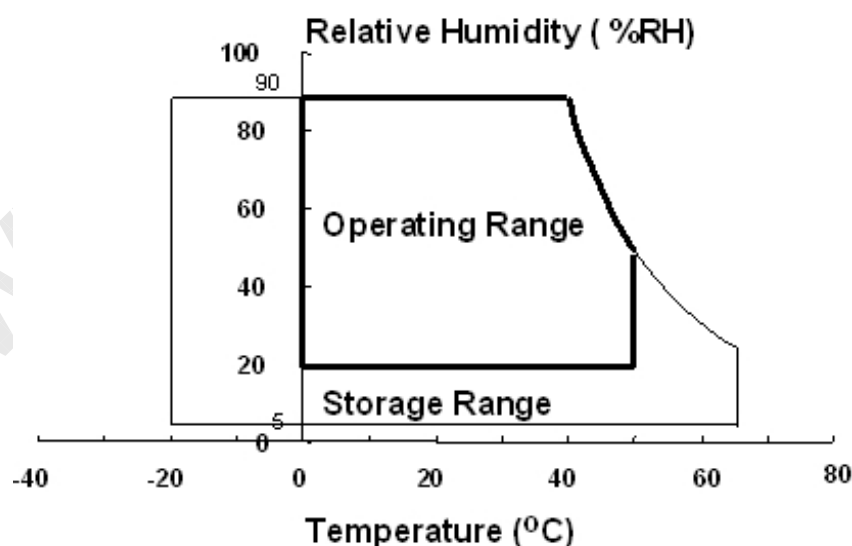

## (5) Definition of test point

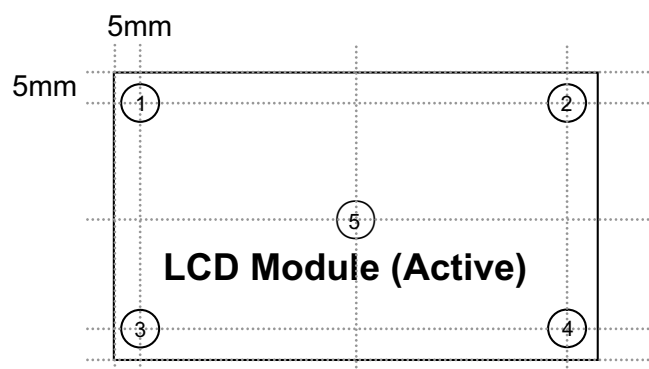

$\Delta T$  should be less than  $10\text{ }^{\circ}\text{C}$  ( $\Delta T = |T_{\text{OPR}} - T_{\text{MAX}}|$ )

$T_{\text{OPR}}$  : Temperature of the center of the glass surface (Test point 5)

$T_1 \sim T_4$  : Temperature of each edge of the glass surface

$T_{\text{MAX}}$  : The highest temperature of the glass surface

## 2. Optical Characteristics

The optical characteristics should be measured in a dark room or equivalent.

Measuring equipment :TOPCON RD-80S, TOPCON SR-3 ,ELDIM EZ-Contrast

(Ta = 25 ± 2°C, VDD=12V, fv=120Hz, f<sub>DCLK</sub>=297MHz, I<sub>L</sub> =11.5 mArms)

Item	Symbol	Condition	Min.	Typ.	Max.	Unit	Note	
Contrast Ratio (Center of screen)	C/R	Normal $\theta_{L,R}=0$ $\theta_{U,D}=0$  Viewing Angle	-	6000	-		(1) SR-3	
Response Time	G-to-G		Tg	-	6	7.5	msec	(3) RD-80S
Luminance of White (Center of screen)	Y <sub>L</sub>			350	450	-	cd/m <sup>2</sup>	(4) SR-3
Color Chromaticity (CIE 1931)	Red		Rx	TYP. -0.03	0.640	TYP. +0.03		(5),(6) SR-3
			Ry		0.340			
	Green		Gx		0.300			
			Gy		0.600			
	Blue		Bx		0.150			
			By		0.060			
	White		Wx		0.280			
		Wy	0.290					
Color Gamut	-	-	72	-	%	(5) SR-3		
Color Temperature	-	-	10000	-	K			
Viewing Angle	Hor.	$\theta_L$	79	89	-	Degree	(6) EZ- Contrast	
		$\theta_R$	79	89	-			
	Ver.	$\theta_U$	79	89	-			
		$\theta_D$	79	89	-			
Brightness Uniformity (9 Points)	B <sub>uni</sub>		-	-	25	%	(2) SR-3	

### - Test Equipment Setup

The measurement should be executed in a stable, windless and dark room between 40min and 60min after lighting the back light at the given temperature for stabilization of the back light. This should be measured in the center of screen.

Total Lamp current : 6.5 mA

Environment condition : Ta = 25 ± 2 °C

MODEL

LTA550HJ06

Doc. No

06-000-S-100407

Page

7/27

Photo detector	Field
SR-3	1°
RD-80S	2°

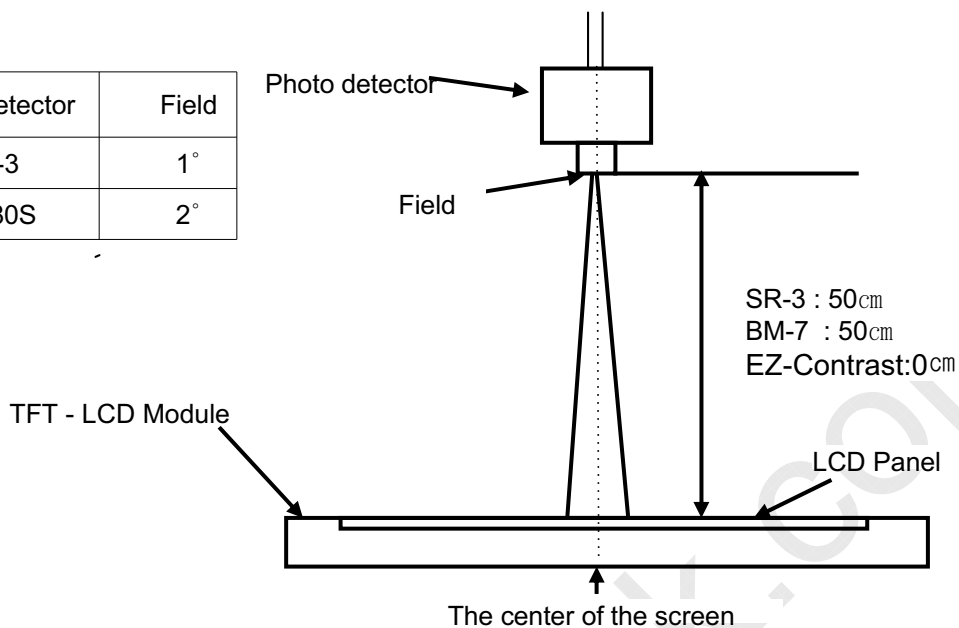

- Definition of test point

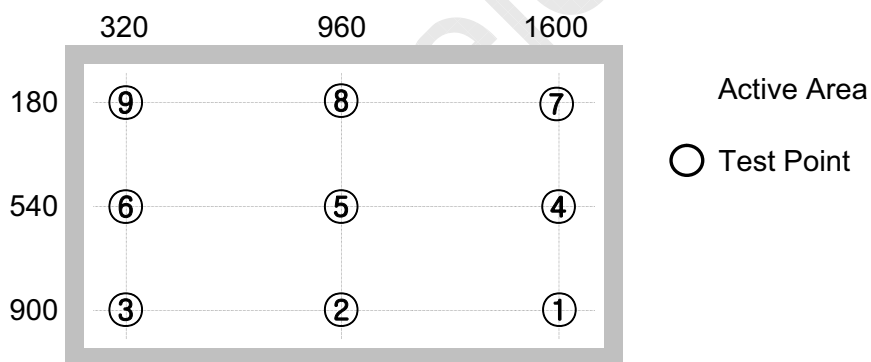

Note (1) Definition of Contrast Ratio (C/R)

: Ratio of gray max (Gmax) & gray min (Gmin) at the center point ⑤ of the panel

$$C/R = \frac{G_{max}}{G_{min}}$$

Gmax : Luminance with all pixels white

Gmin : Luminance with all pixels black

MODEL	LTA550HJ06	Doc. No	06-000-S-100407	Page	8/27
-------	------------	---------	-----------------	------	------



Note (2) Definition of 9 points brightness uniformity (Test pattern : Full White)

$$B_{uni} = 100 * \frac{(B_{max} - B_{min})}{B_{max}}$$

Bmax : Maximum brightness

Bmin : Minimum brightness

Note (3) Definition of Response time : Sum of Tr, Tf

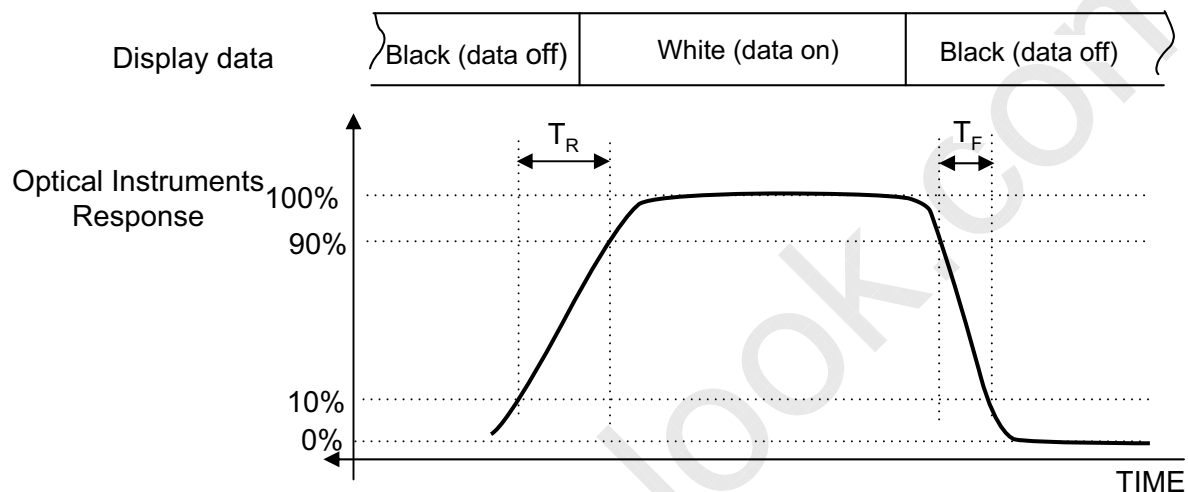

※ G-to-G : Average response time between Gray to Gray (Scale)

Note (4) Definition of Luminance of White : Luminance of white at center point ⑤

Note (5) Definition of Color Chromaticity (CIE 1931)

Color coordinate of Red, Green, Blue & White at center point ⑤

Note (6) Definition of Viewing Angle

: Viewing angle range (C/R  $\geq 10$ )

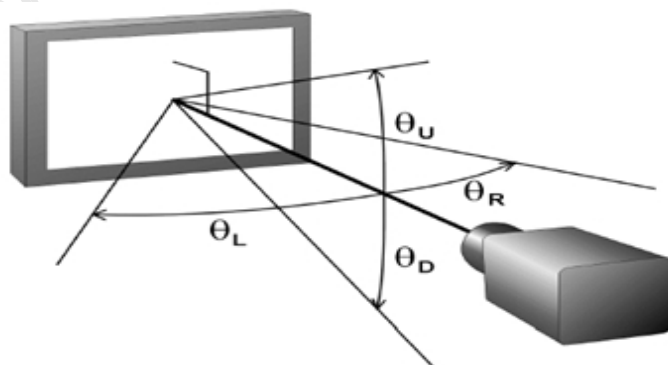

### 3. Electrical Characteristics

#### 3.1 TFT LCD Module

The connector for display data & timing signal should be connected.

$T_a = 25^\circ\text{C} \pm 2^\circ\text{C}$

Item	Symbol	Min.	Typ.	Max.	Unit	Note
Voltage of Power Supply	$V_{DD}$	10.8	12.0	13.2	V	(1)
Current of Power Supply	(a) Black	-	700	850	mA	(2),(3)
	(b) White	-	700	850	mA	
	(c) Sub-Vstripe	-	1450	1650	mA	
Vsync Frequency	$f_V$	95	120	125	Hz	
Hsync Frequency	$f_H$	120	135	140	kHz	
Main Frequency	Fdclk	260	297	305	MHz	
Rush Current	$I_{RUSH}$	-	-	7	A	(4)

Note (1) The ripple voltage should be controlled under 10% of  $V_{DD}$ .

(2)  $f_V = 120\text{Hz}$ ,  $f_{DCLK} = 297\text{MHz}$ ,  $V_{DD} = 12\text{V}$ , DC Current.

(3) Power dissipation check pattern (LCD Module only)

(4) Dual LVDS Signal (4pixel/1clock, Even/Odd)

a) Black Pattern

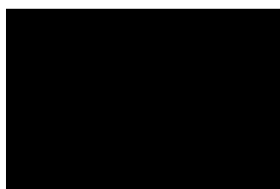

b) White Pattern



c) Sub-Vstripe

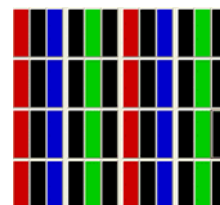

#### (5) Measurement Conditions

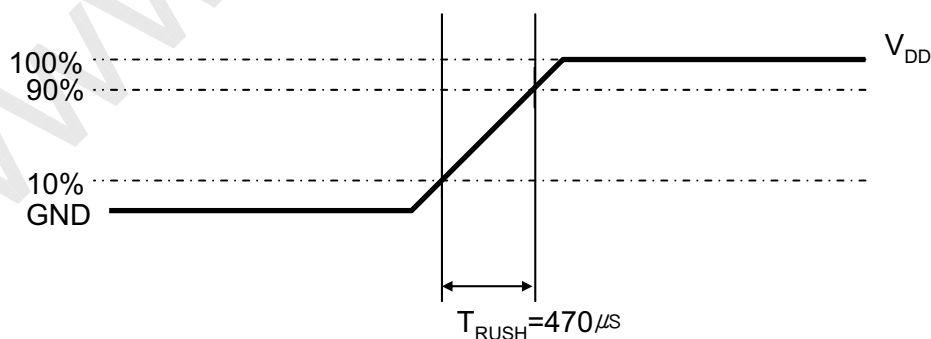

Rush Current  $I_{RUSH}$  can be measured when  $T_{RUSH}$  is  $470\mu\text{s}$ .

MODEL

LTA550HJ06

Doc. No

06-000-S-100407

Page

10/27

### 3.2 Back Light Unit

The back light unit contains 16 Normal CCFL ( Cold Cathode Fluorescent Lamp ).

$T_a = 25 \pm 2^\circ\text{C}$

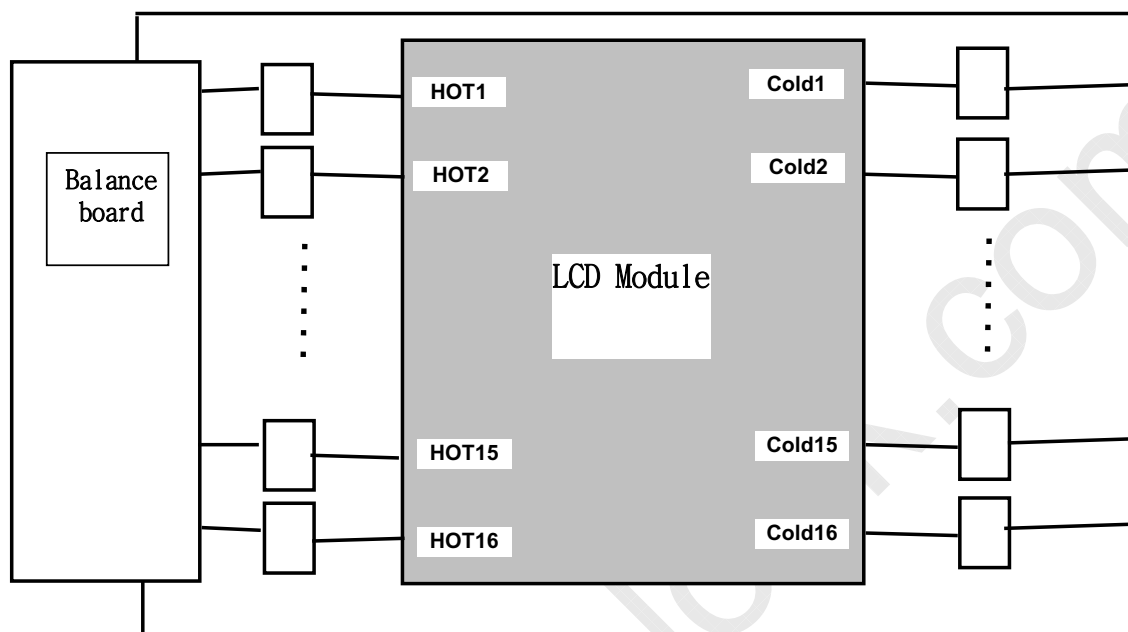

Item	Symbol	Min.	Typ.	Max.	Unit	Note
Operating Life Time	Hr	-	50000	-	Hour	(1)

Note (1) It is defined as the time to take until the brightness reduces to 50% of its original value.

[Operating condition :  $T_a = 25 \pm 2^\circ\text{C}$ ,  $I_L = 6.5\text{mA}$ , For single lamp only. ]

### 3.3 Inverter Input Condition & Specification

Items	Symbol	Conditions	Specifications			Unit	Note
			Min.	Typ.	Max.		
Input Voltage	V <sub>in</sub>	-	22	24	26	V	Ta=25±2 °C
Input Current	I <sub>RUSH</sub>	V <sub>in</sub> = 24V V <sub>dim</sub> = 3.3V	-	-	10.72	A	(1)
Lamp Current	I <sub>o</sub>	V <sub>in</sub> = 24V V <sub>dim</sub> = 3.3V	10.4	11.0	11.6	mArms	(2)
PWM Frequency	F <sub>INV_PWM</sub>	V <sub>in</sub> = 24V Dim = 0v	140	150	160	Hz	-
Backlight On/Off	ON	V <sub>in</sub> = 24V	2.4	-	5.5	V	(3)
	OFF	V <sub>in</sub> = 24V	0	-	0.8		
Dimming Control	V <sub>DIM</sub>	Max Lum	3.3	-	-	V	(4)
		Min. Lum	-	-	0		

Note) Power Consumption is measured when 450[cd/m<sup>2</sup>] of luminance which is the typical luminance.

Lamp Current is measured at the point before Lamp.

- (1) Max Value of the Power Consumption is measured during initial turn-on time\* of the backlight.
- (2) Max Value of the Power Consumption is measured after 60 min warm-up.
- (3) Inverter pin NO.12 is for backlight On/Off.
- (4) Inverter pin NO.13 is for dimming control.

\* Initial turn-on time : From 0sec to 60min after turn-on

MODEL

LTA550HJ06

Doc. No

06-000-S-100407

Page

12/27

## 4. Input Terminal Pin Assignment

### 4.1. Input Signal & Power

Pin Number	Signal	Pin Number	Signal	Pin Number	Signal
1	Panel_VCC	27	Ch3[1]-	53	Ch4[4]+
2	Panel_VCC	28	Ch3[1]+	54	Ch4[4]-
3	Panel_VCC	29	Ch3[2]-	55	Ch4[3]+
4	Panel_VCC	30	Ch3[2]+	56	Ch4[3]-
5	Panel_VCC	31	GND	57	GND
6	N.C	32	Ch3CLK-	58	Ch4CLK+
7	GND	33	Ch3CLK+	59	Ch4CLK-
8	GND	34	GND	60	GND
9	GND	35	Ch3[3]-	61	Ch4[2]+
10	Ch1[0]-	36	Ch3[3]+	62	Ch4[2]-
11	Ch1[0]+	37	Ch3[4]-	63	Ch4[1]+
12	Ch1[1]-	38	Ch3[4]+	64	Ch4[1]-
13	Ch1[1]+	39	GND	65	Ch4[0]+
14	Ch1[2]-	40	SCL_I(for TCON)	66	Ch4[0]-
15	Ch1[2]+	41	NC	67	GND
16	GND	42	NC	68	Ch2[4]+
17	Ch1CLK-	43	WP(EEPROM)	69	Ch2[4]-
18	Ch1CLK+	44	SDA_I(for TCON)	70	Ch2[3]+
19	GND	45	LVDS_SEL	71	Ch2[3]-
20	Ch1[3]-	46	NC	72	GND
21	Ch1[3]+	47	NC	73	Ch2CLK+
22	Ch1[4]-	48	NC	74	Ch2CLK-
23	Ch1[4]+	49	NC	75	GND
24	GND	50	NC	76	Ch2[2]+
25	Ch3[0]-	51	NC(HVS for LCD)	77	Ch2[2]-
26	Ch3[0]+	52	GND	78	Ch2[1]+
(NC) NOT CONNECTED : THIS PINS ARE ONLY USED FOR SEC INTERNAL OPERATIONS. (LVDS_SEL) : IF THIS PIN : HIGH (3.3V) → NORMAL NS LVDS FORMAT				79	Ch2[1]-
				80	Ch2[0]+
				81	Ch2[0]-
				82	GND

MODEL

LTA550HJ06

Doc. No

06-000-S-100407

Page

13/27

Note(1) Pin number starts from Right side

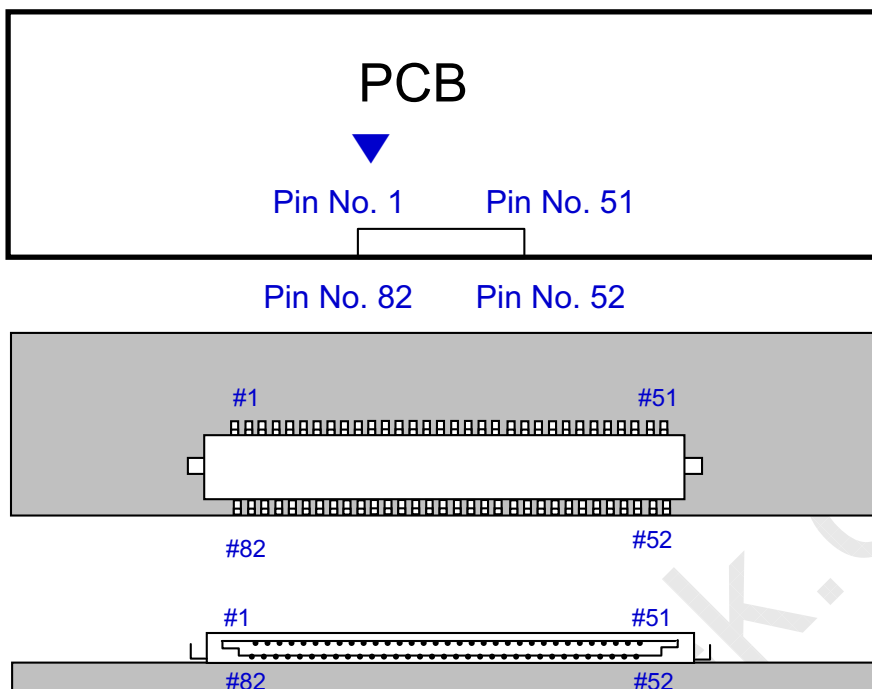
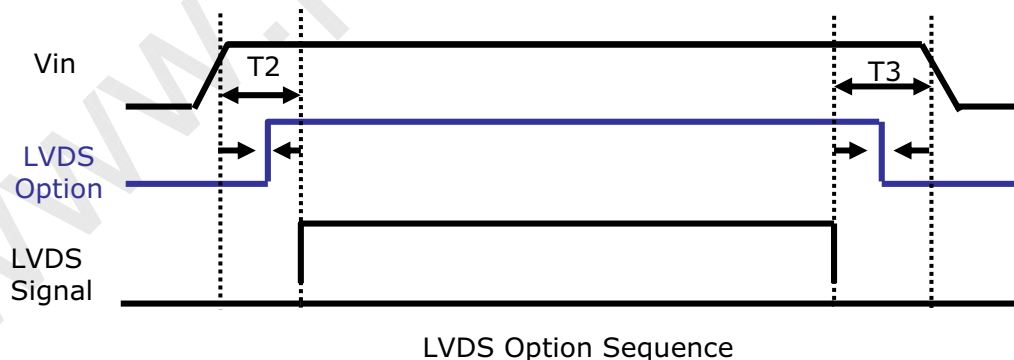

Fig. Connector diagram

- a. Power GND pins should be connected to the LCD's metal chassis.
- b. All power input pins should be connected together.
- c. All NC pin should be separated from other signal or power.

Note(2) LVDS OPTION : If this PIN HIGH ( 3.3V ) → Normal LVDS format  
 LOW ( GND ) → JEIDA LVDS format

SEQUENCE : On = VDD(T1) → LVDS Option → Interface Signal(T2)  
 OFF = Interface Signal(T3) → LVDS Option → VDD



MODEL	LTA550HJ06	Doc. No	06-000-S-100407	Page	14/27
-------	------------	---------	-----------------	------	-------

## 4.2 Inverter Input Pin Configuration

Connector : JST, S14B-PHA-SM-TB(LF)

Pin No.	Pin Configuration (FUNCTION)
1	Vin (24 V)
2	Vin (24 V)
3	Vin (24 V)
4	Vin (24 V)
5	Vin (24 V)
6	GND
7	GND
8	GND
9	GND
10	GND
11	<b>No Connection (DO NOT CONNECT)</b>
12	Backlight On /Off [ON: 2.4 ~ 5.5 V, OFF: 0 ~ 0.8 V]
13	Dimming Control [ 0V: Min, 3.3V: Max ]
14	<b>No Connection (DO NOT CONNECT)</b>

## 4.3. Inverter Input Power Sequence

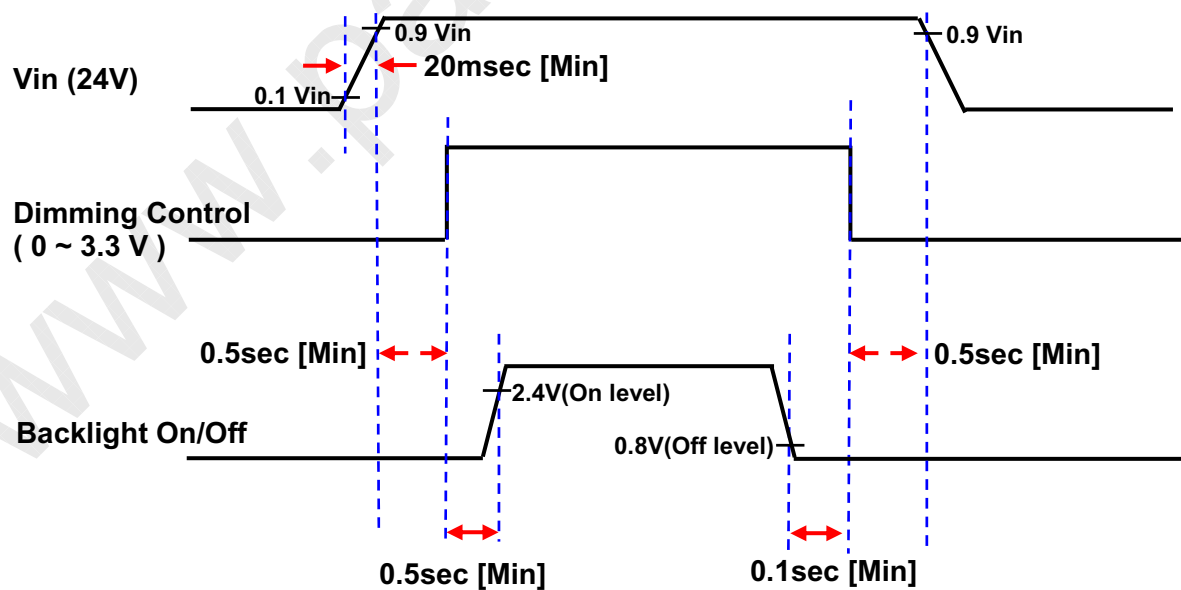

MODEL

LTA550HJ06

Doc. No

06-000-S-100407

Page

15/27

## 4.3 LVDS Interface

- LVDS Receiver : Tcon (merged)

- Data Format (JEIDA)

	LVDS pin	JEIDA -DATA
TxOUT/RxIN0	TxIN/RxOUT0	R4
	TxIN/RxOUT1	R5
	TxIN/RxOUT2	R6
	TxIN/RxOUT3	R7
	TxIN/RxOUT4	R8
	TxIN/RxOUT6	R9
	TxIN/RxOUT7	G4
TxOUT/RxIN1	TxIN/RxOUT8	G5
	TxIN/RxOUT9	G6
	TxIN/RxOUT12	G7
	TxIN/RxOUT13	G8
	TxIN/RxOUT14	G9
	TxIN/RxOUT15	B4
	TxIN/RxOUT18	B5
TxOUT/RxIN2	TxIN/RxOUT19	B6
	TxIN/RxOUT20	B7
	TxIN/RxOUT21	B8
	TxIN/RxOUT22	B9
	TxIN/RxOUT24	HSYNC
	TxIN/RxOUT25	VSYNC
	TxIN/RxOUT26	DEN
TxOUT/RxIN3	TxIN/RxOUT27	R2
	TxIN/RxOUT5	R3
	TxIN/RxOUT10	G2
	TxIN/RxOUT11	G3
	TxIN/RxOUT16	B2
	TxIN/RxOUT17	B3
	TxIN/RxOUT23	RESERVED
TxOUT/RxIN4	TxIN/RxOUT28	R0
	TxIN/RxOUT29	R1
	TxIN/RxOUT30	G0
	TxIN/RxOUT31	G1
	TxIN/RxOUT32	B0
	TxIN/RxOUT33	B1
	TxIN/RxOUT34	REVERSED

MODEL

LTA550HJ06

Doc. No

06-000-S-100407

Page

16/27



### 4.4 Input Signals, Basic Display Colors and Gray Scale of Each Color

COLOR	DISPLAY (8bit)	DATA SIGNAL																								GRAY SCALE LEVEL
		RED							GREEN							BLUE										
		R0	R1	R2	R3	R4	R5	R6	R7	G0	G1	G2	G3	G4	G5	G6	G7	B0	B1	B2	B3	B4	B5	B6	B7	
BASIC COLOR	BLACK	0	0	0	0	0	0	0	0	0	0	0	0	0	0	0	0	0	0	0	0	0	0	0	0	-
	BLUE	0	0	0	0	0	0	0	0	0	0	0	0	0	0	0	0	1	1	1	1	1	1	1	1	-
	GREEN	0	0	0	0	0	0	0	0	1	1	1	1	1	1	1	1	0	0	0	0	0	0	0	0	-
	CYAN	0	0	0	0	0	0	0	0	1	1	1	1	1	1	1	1	1	1	1	1	1	1	1	1	-
	RED	1	1	1	1	1	1	1	1	0	0	0	0	0	0	0	0	0	0	0	0	0	0	0	0	-
	MAGENTA	1	1	1	1	1	1	1	1	0	0	0	0	0	0	0	0	1	1	1	1	1	1	1	1	-
	YELLOW	1	1	1	1	1	1	1	1	1	1	1	1	1	1	1	1	0	0	0	0	0	0	0	0	-
	WHITE	1	1	1	1	1	1	1	1	1	1	1	1	1	1	1	1	1	1	1	1	1	1	1	1	-
GRAY SCALE OF RED	BLACK	0	0	0	0	0	0	0	0	0	0	0	0	0	0	0	0	0	0	0	0	0	0	0	R0	
	DARK ↑	1	0	0	0	0	0	0	0	0	0	0	0	0	0	0	0	0	0	0	0	0	0	0	R1	
		0	1	0	0	0	0	0	0	0	0	0	0	0	0	0	0	0	0	0	0	0	0	0	R2	
		:	:	:	:	:	:	:	:	:	:	:	:	:	:	:	:	:	:	:	:	:	:	:	R3~R252	
		:	:	:	:	:	:	:	:	:	:	:	:	:	:	:	:	:	:	:	:	:	:	:		
	LIGHT ↓	1	0	1	1	1	1	1	1	0	0	0	0	0	0	0	0	0	0	0	0	0	0	0	R253	
		0	1	1	1	1	1	1	1	0	0	0	0	0	0	0	0	0	0	0	0	0	0	0	R254	
	RED	1	1	1	1	1	1	1	1	0	0	0	0	0	0	0	0	0	0	0	0	0	0	0	R255	
GRAY SCALE OF GREEN	BLACK	0	0	0	0	0	0	0	0	0	0	0	0	0	0	0	0	0	0	0	0	0	0	0	G0	
	DARK ↑	0	0	0	0	0	0	0	0	1	0	0	0	0	0	0	0	0	0	0	0	0	0	0	G1	
		0	0	0	0	0	0	0	0	0	1	0	0	0	0	0	0	0	0	0	0	0	0	0	G2	
		:	:	:	:	:	:	:	:	:	:	:	:	:	:	:	:	:	:	:	:	:	:	:	G3~G252	
		:	:	:	:	:	:	:	:	:	:	:	:	:	:	:	:	:	:	:	:	:	:	:		
	LIGHT ↓	0	0	0	0	0	0	0	0	1	0	1	1	1	1	1	1	0	0	0	0	0	0	0	G253	
		0	0	0	0	0	0	0	0	0	1	1	1	1	1	1	1	0	0	0	0	0	0	0	G254	
	GREEN	0	0	0	0	0	0	0	0	1	1	1	1	1	1	1	1	0	0	0	0	0	0	0	G255	
GRAY SCALE OF BLUE	BLACK	0	0	0	0	0	0	0	0	0	0	0	0	0	0	0	0	0	0	0	0	0	0	0	B0	
	DARK ↑	0	0	0	0	0	0	0	0	0	0	0	0	0	0	0	0	1	0	0	0	0	0	0	B1	
		0	0	0	0	0	0	0	0	0	0	0	0	0	0	0	0	0	1	0	0	0	0	0	B2	
		:	:	:	:	:	:	:	:	:	:	:	:	:	:	:	:	:	:	:	:	:	:	:	B3~B252	
		:	:	:	:	:	:	:	:	:	:	:	:	:	:	:	:	:	:	:	:	:	:	:		
	LIGHT ↓	0	0	0	0	0	0	0	0	0	0	0	0	0	0	0	0	1	0	1	1	1	1	1	B253	
		0	0	0	0	0	0	0	0	0	0	0	0	0	0	0	0	0	1	1	1	1	1	1	B254	
	BLUE	0	0	0	0	0	0	0	0	0	0	0	0	0	0	0	0	1	1	1	1	1	1	1	B255	

Note) Definition of Gray :

Rn : Red Gray, Gn : Green Gray, Bn : Blue Gray (n = Gray level)

Input Signal : 0 = Low level voltage, 1 = High level voltage

MODEL	LTA550HJ06	Doc. No	06-000-S-100407	Page	17/27
-------	------------	---------	-----------------	------	-------

## 5. Interface Timing

### 5.1 Timing Parameters (DE only mode)

SIGNAL	ITEM	SYMBOL	MIN.	TYP.	MAX.	Unit	NOTE
Clock	Frequency	$1/T_C$	260	297	305	MHz	4pixels/ clk
Hsync		$F_H$	120	135	140	KHz	-
Vsync		$F_V$	95	120	125	Hz	-
Vertical Display Term	Active Display Period	$T_{VD}$	-	1080	-	Lines	-
	Vertical Total	$T_V$	1092	1125	1350	Lines	-
Horizontal Display Term	Active Display Period	$T_{HD}$	-	1920	-	Clocks	-
	Horizontal Total	$T_H$	2090	2200	2350	clocks	-

Note) This product is DE only mode. The input of Hsync & Vsync signal does not have an effect on normal operation.

## 5.2 Power ON/OFF Sequence

To prevent a latch-up or DC operation of the LCD Module, the power on/off sequence should be as the diagram below.

$$\begin{aligned} 0.5 < T1 &\leq 10\text{ms} \\ 0 < T2 &\leq 50\text{ms} \\ 0 < T3 &\leq 50\text{ms} \\ 1000\text{ms} &\leq T4 \end{aligned}$$

$$\begin{aligned} 1000\text{ms} &\leq T5 \\ &\text{(Recommend Value)} \\ 100\text{ms} &\leq T6 \\ &\text{(Recommend Value)} \end{aligned}$$

T1 :  $V_{DD}$  rising time from 10% to 90%

T2 : The time from  $V_{DD}$  to valid data at power ON.

T3 : The time from valid data off to  $V_{DD}$  off at power Off.

T4 :  $V_{DD}$  off time for Windows restart

T5 : The time from valid data to B/L enable at power ON.

T6 : The time from valid data off to B/L disable at power Off.

- The supply voltage of the external system for the Module input should be the same as the definition of  $V_{DD}$ .
- Apply the lamp voltage within the LCD operation range. When the back light turns on before the LCD operation or the LCD turns off before the back light turns off, the display may momentarily show abnormal screen.
- In case of  $V_{DD}$  = off level, please keep the level of input signals low or keep a high impedance.
- T4 should be measured after the Module has been fully discharged between power off and on period.
- Interface signal should not be kept at high impedance when the power is on.

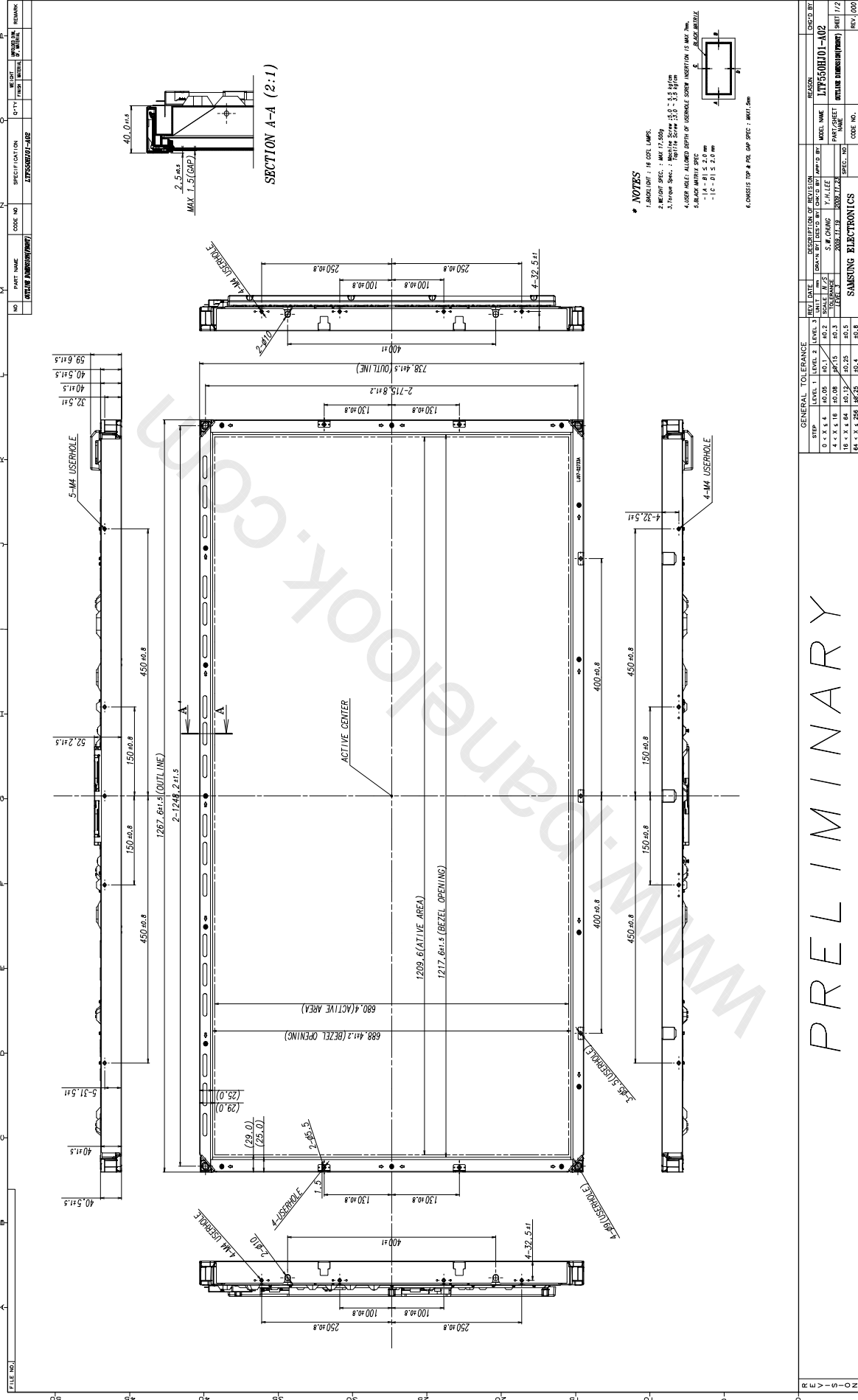

- NOTES**
1. DIMENSION : IN DEC. LINES.
  2. BEZEL SPEC. : MAX. 17.500mm
  3. FRAME SPEC. : BEZEL THICKNESS 3.0 ± 0.3 mm
  4. USER HOLE: ALLOWED DEPTH OF USER HOLE SHOULD NOT EXCEED 1.5 mm.
  5. BEZEL MOUNTING SPEC. :  
- 1-C-D1 ≤ 2.0 mm
  6. CHASSIS TOP # POL. GAP SPEC. : MAX. 5mm

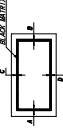

PRELIMINARY

GENERAL TOLERANCE		REVISION		DESCRIPTION OF REVISION		REASON	
STEP	LEVEL	NO.	DATE	BY	DATE	NO.	DATE
0 - X ± 4	±0.05	±0.1					
1 - X ± 4	±0.05	±0.1					
2 - X ± 4	±0.05	±0.1					
3 - X ± 4	±0.05	±0.1					
4 - X ± 4	±0.05	±0.1					
5 - X ± 4	±0.05	±0.1					
6 - X ± 4	±0.05	±0.1					
7 - X ± 4	±0.05	±0.1					
8 - X ± 4	±0.05	±0.1					
9 - X ± 4	±0.05	±0.1					
10 - X ± 4	±0.05	±0.1					
11 - X ± 4	±0.05	±0.1					
12 - X ± 4	±0.05	±0.1					
13 - X ± 4	±0.05	±0.1					
14 - X ± 4	±0.05	±0.1					
15 - X ± 4	±0.05	±0.1					
16 - X ± 4	±0.05	±0.1					
17 - X ± 4	±0.05	±0.1					
18 - X ± 4	±0.05	±0.1					
19 - X ± 4	±0.05	±0.1					
20 - X ± 4	±0.05	±0.1					
21 - X ± 4	±0.05	±0.1					
22 - X ± 4	±0.05	±0.1					
23 - X ± 4	±0.05	±0.1					
24 - X ± 4	±0.05	±0.1					
25 - X ± 4	±0.05	±0.1					
26 - X ± 4	±0.05	±0.1					
27 - X ± 4	±0.05	±0.1					
28 - X ± 4	±0.05	±0.1					
29 - X ± 4	±0.05	±0.1					
30 - X ± 4	±0.05	±0.1					
31 - X ± 4	±0.05	±0.1					
32 - X ± 4	±0.05	±0.1					
33 - X ± 4	±0.05	±0.1					
34 - X ± 4	±0.05	±0.1					
35 - X ± 4	±0.05	±0.1					
36 - X ± 4	±0.05	±0.1					
37 - X ± 4	±0.05	±0.1					
38 - X ± 4	±0.05	±0.1					
39 - X ± 4	±0.05	±0.1					
40 - X ± 4	±0.05	±0.1					
41 - X ± 4	±0.05	±0.1					
42 - X ± 4	±0.05	±0.1					
43 - X ± 4	±0.05	±0.1					
44 - X ± 4	±0.05	±0.1					
45 - X ± 4	±0.05	±0.1					
46 - X ± 4	±0.05	±0.1					
47 - X ± 4	±0.05	±0.1					
48 - X ± 4	±0.05	±0.1					
49 - X ± 4	±0.05	±0.1					
50 - X ± 4	±0.05	±0.1					



## 7. Reliability Test

Item	Test condition	Quantity
Temperature Step stress	-20℃ ~ 60℃, 10Cycle, 80hr	4EA
HTOL	50℃operation, 1000hr	8EA
LTOL	0℃operation, 1000hr	4EA
LTOL 2	-20℃, -10℃ Each condition over 5hr off, over 1hr on	4EA
HTS	70℃storage, 500hr	4EA
LTS	-30℃storage, 500hr	4EA
THB	40℃ / 95%RH, 30sec On / Off , 500hr operation	4EA
WHTS	60℃ / 75%RH, 500hr	4EA
Thermal Shock	-20℃(30min) ~ 60℃(30min) storage, 200cycle	4EA
ALTITUDE	-10℃ ~ 45℃, 0 ~ 40,000ft , 18hr	2EA
ESD	contact : ± 8 kV ,150pF/330Ω ,200Point,1 time/Point (operation) non-contact : ± 15 kV ,150pF/330Ω ,200Point,1 time/Point (operation) Inverter input pin : ± 15 kV ,150pF/330Ω , 3 times/Pin	3EA
Vibration	10~300Hz/1.5G/10minSR, XYZ, 30min/axis	3EA
Shock	30G, 11msec, ±XYZ 1time/axis	3EA
Noise	On 90 min / Off 90 min	2 EA
Dust	5hr on/off (yellow earth 5sec spread / 5 min precipitation)	2 EA
Short term Image sticking	25~50℃ Mosaic pattern (9*10) 12hr fix	8 EA
Long term Image sticking	50℃ Mosaic pattern (9*10) 504hr fix	4 EA
PALLET Vibration	1.05 Grms, Random, Z axis 1Hr	1PALLET(9EA)
PALLET Drop	20cm, 4Edge(Bottom), 1Face(Bottom)	1PALLET(9EA)

### [ Result Evaluation Criteria]

Under the display quality test conditions with normal operation state, these should be no change which may affect practical display functions.

- \* HTOL/ LTOL : High/Low Temperature Operating Life
- \*\* THB : Temperature Humidity Bias
- \*\*\* HTS/LTS : High/Low Temperature Storage
- \*\*\*\* WHTS : Wet High Temperature Storage

MODEL

LTA550HJ06

Doc. No

06-000-S-100407

Page

22/27

## 8. PACKING

### 8.1 CARTON (Internal Package)

#### (1) Packing Form

Corrugated fiberboard box and corrugated cardboard as shock absorber

#### (2) Packing Method

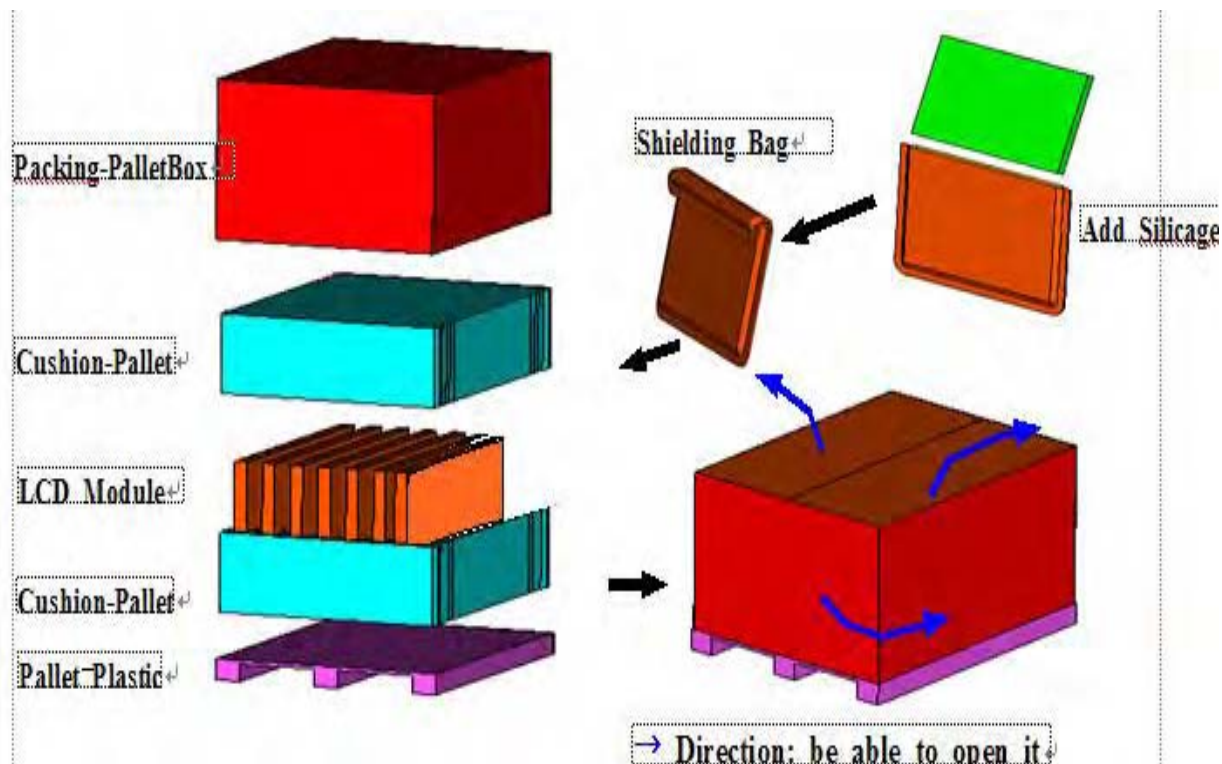

### 8.2 Packing Specification

Item	Specification	Remark
LCD Packing	9ea / (Packing-Pallet Box)	1. 157.5Kg / LCD (9ea) 2. 13.4 Kg / Cushion-pallet (2ea) 3. 10.5 Kg / Packing-Pallet Box (1ea) >. Cushion-pallet Material : EPS >. Packing-Pallet Box Material : SW4
Pallet	1Box / Pallet	1. Pallet weight = 10kg >. Pallet Material : HDPE
Packing Direction	Vertical	
Total Pallet Size	H x V x height	1475mm(H) x 1150mm(V) x 995mm(height)
Total Pallet Weight	191.4 kg	Pallet(10kg) + Module(17.5*9=157.5) + Cushion(up+botton=13.4kg) + Pallet- BOX(10.5kg)

MODEL

LTA550HJ06

Doc. No

06-000-S-100407

Page

23/27

## 9. MARKING & OTHERS

A nameplate bearing followed by is affixed to a shipped product at the specified location on each product.

- (1) Part number : LTF550HJ01
- (2) Revision: letters
- (3) Lot number : X X X X XXX XX X

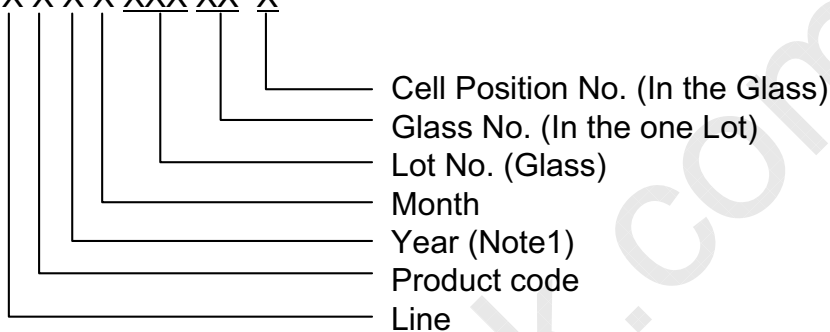

### (4) Nameplate Indication

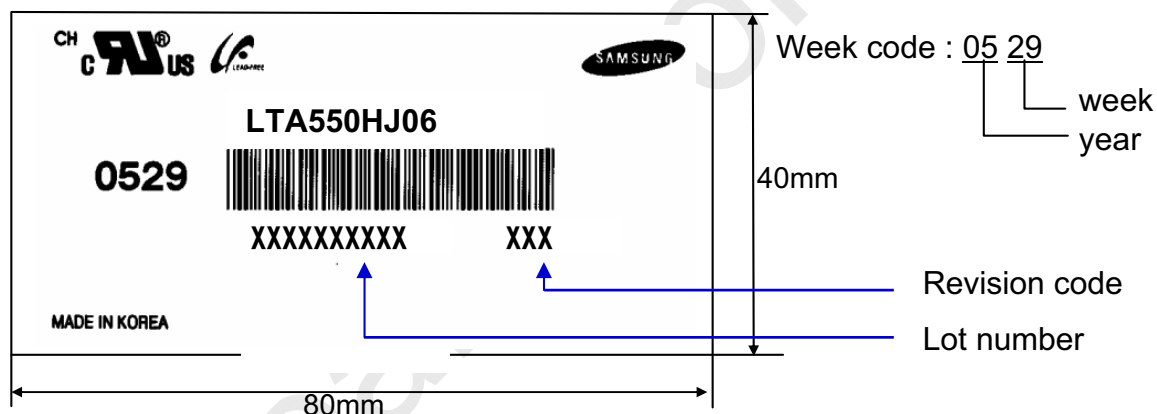

### (5) Packing box attach

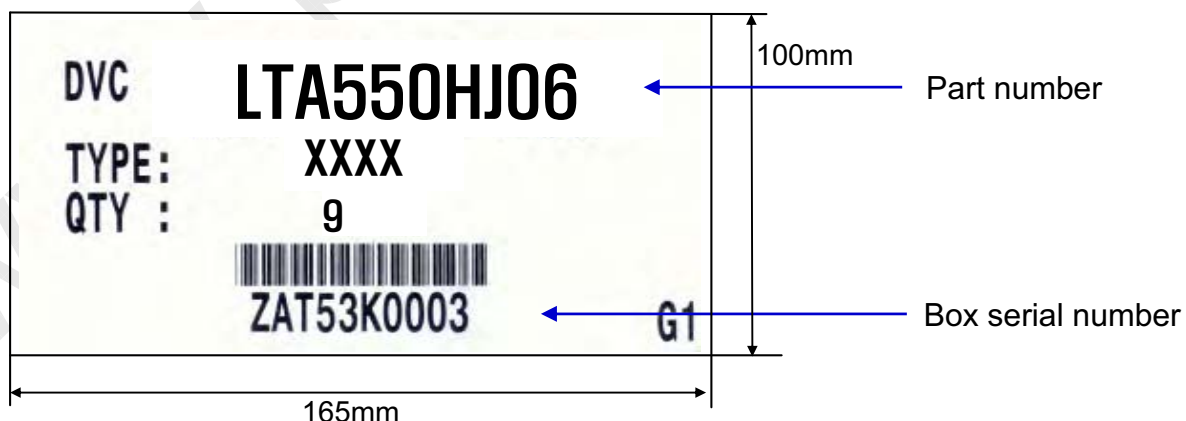

### (6) Others

- 1. After service part  
 Lamps cannot be replaced because of the narrow bezel structure.

MODEL	LTA550HJ06	Doc. No	06-000-S-100407	Page	24/27
-------	------------	---------	-----------------	------	-------



## 10. General Precautions

### 10.1 Handling

- (a) When the Module is assembled, it should be attached to the system firmly using all mounting holes. Be careful not to twist and bend the Module.
- (b) Because the inverter use high voltage, it should be disconnected from power before it is assembled or disassembled.
- (c) Refrain from strong mechanical shock and / or any force to the Module. In addition to damage, this may cause improper operation or damage to the Module and CCFL back light.
- (d) Note that polarizers are very fragile and could be damage easily. Do not press or scratch the surface harder than a HB pencil lead.
- (e) Wipe off water droplets or oil immediately. If you leave the droplets for a long time, staining or discoloration may occur.
- (f) If the surface of the polarizer is dirty, clean it using absorbent cotton or soft cloth.
- (g) Desirable cleaners are water, IPA(Isopropyl Alcohol) or Hexane. Do not use Ketone type materials(ex. Acetone), Ethyl alcohol, Toluene, Ethyl acid or Methyl chloride. It might permanent damage to the polarizer due to chemical reaction.
- (h) If the liquid crystal material leaks from the panel, it should be kept away from the eyes or mouth . In case of contact with hands, legs or clothes, it must be washed away with soap thoroughly.
- (i) Protect the module from Electrostatic discharge. Otherwise the ASIC IC or Semiconductor would be damaged.
- (j) Use finger-stalls with soft gloves in order to keep display clean during the incoming inspection and assembly process.
- (k) Do not disassemble the Module.
- (l) Do not disassemble shield case of inverter & LVDS board.
- (m) Do not connect N.C pins. (Samsung internal use only)
- (n) Protection film for polarizer on the Module should be slowly peeled off just before use so that the electrostatic charge can be minimized. Must put on antistatic glove while handle a module
- (o) Pins of I/F connector should not be touched directly with bare hands.

MODEL

LTA550HJ06

Doc. No

06-000-S-100407

Page

25/27

## 10.2 Storage

- (a) Do not leave the Module in high temperature, and high humidity for a long time. It is highly recommended to store the Module with temperature from 0 to 35°C and relative humidity of less than 70%.
- (b) Do not store the TFT-LCD Module in direct sunlight.
- (c) The Module should be stored in a dark place. It is prohibited to apply sunlight or fluorescent light in storing.

## 10.3 Operation

- (a) Do not connect or disconnect the Module in the "Power On" condition.
- (b) Power supply should always be turned on/off by the "Power on/off sequence"
- (c) Module has high frequency circuits. Sufficient suppression to the electromagnetic interference should be done by system manufacturers. Grounding and shielding methods may be important to minimize the interference.
- (d) The cable between the back light connector and its inverter power supply should be connected directly with a minimized length. A longer cable between the back light and the inverter may cause lower luminance of lamp(CCFT) and may require higher startup voltage(Vs).

## 10.4 Operation Condition Guide

- (a) The LCD product should be operated under normal conditions.  
Normal condition is defined as below;
  - Temperature :  $20 \pm 15^{\circ}\text{C}$
  - Humidity :  $55 \pm 20\%$
  - Display pattern : continually changing pattern (Not stationary)
- (b) If the product will be used in extreme conditions such as high temperature, humidity, display patterns or operation time etc., It is strongly recommended to contact SEC for Application engineering advice. Otherwise, its reliability and function may not be guaranteed. Extreme conditions are commonly found at Airports, Transit Stations, Banks, Stock market, and Controlling systems.

MODEL

LTA550HJ06

Doc. No

06-000-S-100407

Page

26/27

## 10.5 Others

- (a) Ultra-violet ray filter is necessary for outdoor operation.
- (b) Avoid condensation of water. It may result in improper operation or disconnection of electrode.
- (c) Do not exceed the absolute maximum rating value. ( supply voltage variation, input voltage variation, variation in part contents and environmental temperature, and so on)  
Otherwise the Module may be damaged.
- (d) If the Module keeps displaying the same pattern for a long period of time, the image may be "sticked" to the screen.  
To avoid image sticking, it is recommended to use a screen saver.
- (e) This Module has its circuitry PCB's on the rear side and should be handled carefully in order not to be stressed.
- (f) Please contact SEC in advance when you display the same pattern for a long time.

MODEL

LTA550HJ06

Doc. No

06-000-S-100407

Page

27/27