

**Samsung Secret**

Product Information

Customer :HISENSE**DATE : 31. Dec. 2009****SAMSUNG TFT-LCD****MODEL : LTA550HQ06-C01**

The Information Described in this Specification is Preliminary and can be changed without prior notice

LCD Business

Samsung Electronics Co . , LTD.

MODEL	LTA550HJ05	Doc. No	06-000-G-091231	Page	1 / 25
-------	------------	---------	-----------------	------	--------

Contents**Samsung Secret**

General Description	-----	(3)
General Information	-----	(3)
1. Absolute Maximum Ratings	-----	(4)
2. Optical Characteristics	-----	(5)
3. Electrical Characteristics	-----	(8)
3.1 TFT LCD Module		
3.2 Back Light Unit		
3.3 Inverter Input & Specification		
4. Input Terminal Pin Assignment	-----	(11)
4.1 Input Signal & Power		
4.2 Converter Input Pin Configuration		
4.3 Converter Input Power Sequence		
4.4 LVDS Interface		
4.5 Input Signals, Basic Display Colors and Gray Scale of Each Color		
5. Interface Timing	-----	(17)
5.1 Timing Parameters (DE only mode)		
5.2 Timing Diagrams of interface Signal (DE only mode)		
5.3 Power ON/OFF Sequence		
6. Outline Dimension	-----	(20)
7. Packing	-----	(22)
8. Marking & Others	-----	(23)
9. General Precaution	-----	(24)
9.1 Handling		
9.2 Storage		
9.3 Operation		
9.4 Operation Condition Guide		
9.5 Others		

MODEL

LTA550HJ05

Doc. No

06-000-G-091231

Page

2 / 25

General Description

Samsung Secret

Description

LTA550HQ06 is a color active matrix liquid crystal display (LCD) that uses amorphous silicon TFT (Thin Film Transistor) as switching components. This model is composed of a TFT LCD panel, a driver circuit and a back light unit. The resolution of a 55.0" is 1920 x 1080 and this model can display up to 16.7 Million colors with wide viewing angle of 89° or higher in all directions. This panel is intended to support applications to provide an excellent performance for Flat Panel Display such as Home-alone Multimedia TFT-LCD TV and High Definition TV

Features

- RoHS compliance (Pb-free)
- High contrast ratio & aperture ratio with wide color gamut
- SPVA (Super Patterned Vertical Align) mode
- Wide viewing angle ($\pm 178^\circ$)
- High speed response (& Natural Motion (DFR: Double Frame Rate))
- FHD resolution (16:9)
- Low Power consumption
- Edge Type LED (Light Emitted Diode) BLU
- DE (Data Enable) mode
- 4ch LVDS (Low Voltage Differential Signaling) interface (4pixel/clock)

General Information

Items	Specification	Unit	Note
Module Size	TBD	mm	$\pm 1.0\text{mm}$
	TBD		
Weight	TBD (Max)	Kg	
Pixel Pitch	0.630(H) x 0.630(W)	mm	
Active Display Area	1209.6(H) X 680.4(V)	mm	
Surface Treatment	Haze 7%, Hard-coating(3H)		
Display Colors	8 bit – 16.7 Million	colors	
Number of Pixels	1920 x 1080	pixel	
Pixel Arrangement	RGB vertical stripe		
Display Mode	Normally Black		
Luminance of White	450 (Typ.)	cd/m ²	

MODEL

LTA550HJ05

Doc. No

06-000-G-091231

Page

3 / 25

Samsung Secret

1. Absolute Maximum Ratings

If the condition exceeds maximum ratings, it can cause malfunction or unrecoverable damage to the device.

Item	Symbol	Min.	Max.	Unit	Note
Power Supply Voltage	V_{DD}	GND-0.5	13.2	V	(1)
Dimming Control	Max. Lum	-	5	V	
Storage temperature	T_{STG}	-20	60	°C	(2)
Operating temperature	T_{OPR}	0	50	°C	
Surface temperature	T_{SUR}	0	60	°C	(3)
Shock (non - operating)	X,Y,Z	-	50	G	(4)
Vibration (non - operating)	V_{NOP}	-	1.5	G	(5)

Note (1) $T_a = 25 \pm 2 \text{ }^\circ\text{C}$

(2) Temperature and relative humidity range are shown in the figure below.

a. 90 % RH Max. ($T_a \leq 39 \text{ }^\circ\text{C}$)

b. Relative Humidity is 90% or less. ($T_a > 39 \text{ }^\circ\text{C}$)

c. No condensation

(3) Although abnormal visual problems can be occurred in T_{SUR} range, the polarizer is not damaged in this range.

(4) 11ms, sine wave, one time for $\pm X, \pm Y, \pm Z$ axis

(5) 10-300 Hz, Sweep rate 10min, 30min for X,Y,Z axis

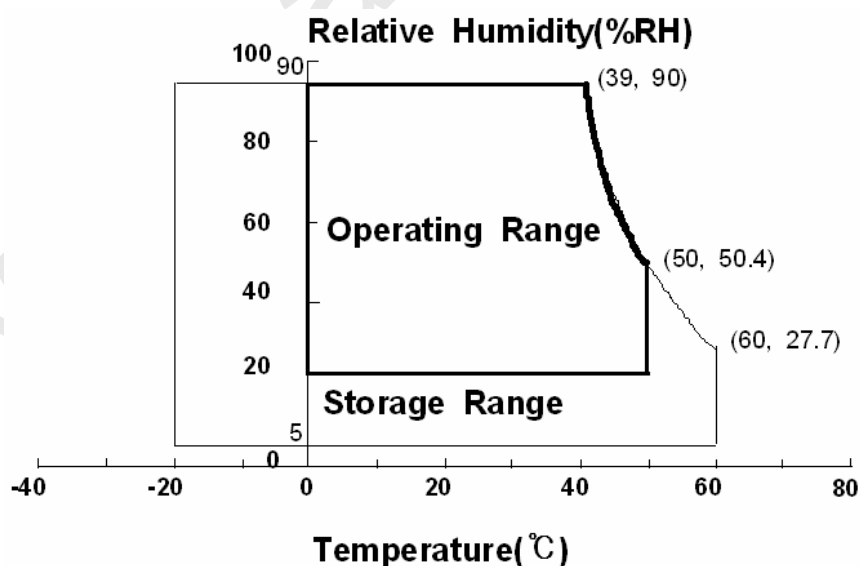

Fig. Temperature and Relative humidity range

MODEL

LTA550HJ05

Doc. No

06-000-G-091231

Page

4 / 25

2. Optical Characteristics

Samsung Secret

The optical characteristics should be measured in a dark room or equivalent.

Measuring equipment : TOPCON RD-80S, TOPCON SR-3, ELDIM EZ-Contrast

(Ta = 25 ± 2°C, VDD=12V, fv= 120Hz, f_{DCLK} = 297.0MHz, LED Current = TBD)

Item	Symbol	Condition	Min.	Typ.	Max.	Unit	Note	
Contrast Ratio (Center of screen)	C/R		4000	5000	-		(1) SR-3	
Response Time G-to-G	Tg		-	6	-	msec	(3) RD-80S	
Luminance of White (Center of screen)	Y _L		350	450	-	cd/m ²	(4) SR-3	
Color Chromaticity (CIE 1931)	Red	Rx	Normal q _{L,R} = 0 q _{U,D} = 0 Viewing Angle	TBD	TYP. -0.03	TYP. +0.03	(5),(6) SR-3	
		Ry		TBD				
	Green	Gx		TBD				
		Gy		TBD				
	Blue	Bx		TBD				
		By		TBD				
	White	Wx		0.280				
		Wy		0.290				
Color Gamut	-		-	74	-	%	(5) SR-3	
Color Temperature	-		-	10,000	-	K		
Viewing Angle	Hor.	q _L	C/R ≥ 10	75	89	-	Degree	(6) EZ-Contrast
		q _R		75	89	-		
	Ver.	q _U		75	89	-		
		q _D		75	89	-		
White Brightness Uniformity (9 Points)	B _{uni}		-	-	25	%	(2) SR-3	

- Test Equipment Setup

The measurement should be executed in a stable, windless and dark room between 40min and 60min after lighting the back light at the given temperature for stabilization of the back light. This should be measured in the center of screen.

Environment condition : Ta = 25 ± 2 °C

MODEL	LTA550HJ05	Doc. No	06-000-G-091231	Page	5 / 25
-------	------------	---------	-----------------	------	--------

Samsung Secret

Photo detector	Field
SR-3	2°
RD-80S	1°

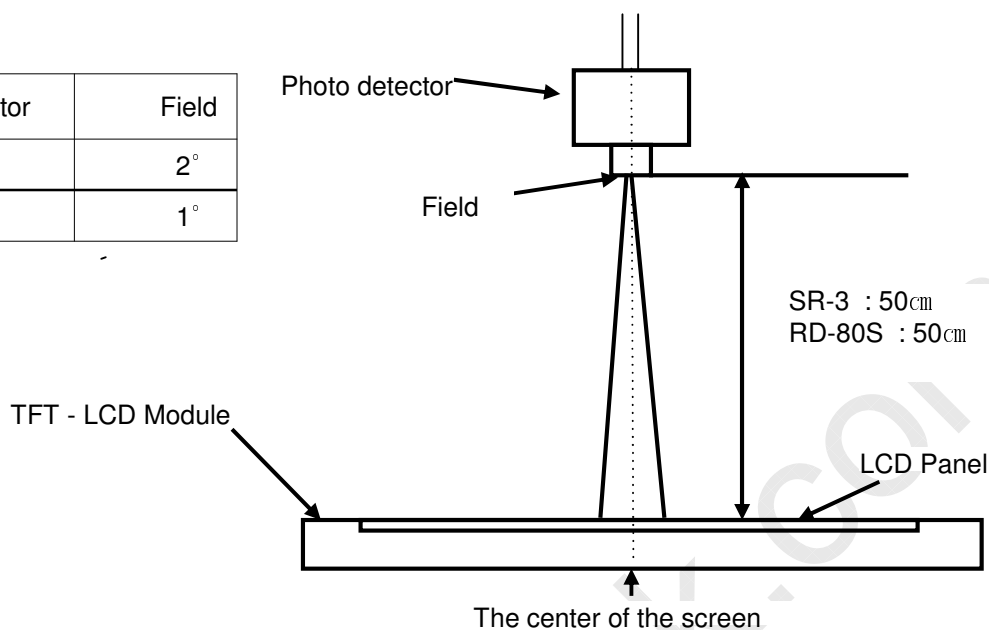

- Definition of test point

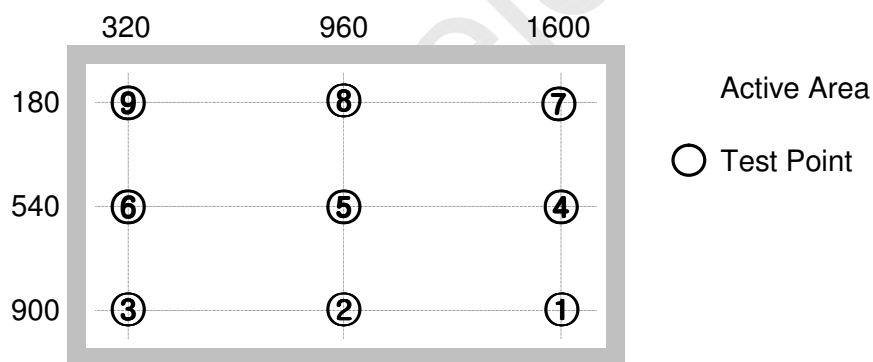

Note (1) Definition of Contrast Ratio (C/R)

: Ratio of gray max (Gmax) & gray min (Gmin) at the center point ⑤ of the panel

$$C/R = \frac{G \max}{G \min}$$

Gmax : Luminance with all pixels white

Gmin : Luminance with all pixels black

MODEL	LTA550HJ05	Doc. No	06-000-G-091231	Page	6 / 25
-------	------------	---------	-----------------	------	--------

Samsung Secret

Note (2) Definition of 9 points brightness uniformity (Test pattern : Full White)

$$B_{uni} = 100 * \frac{(B_{max} - B_{min})}{B_{max}}$$

Bmax : Maximum brightness

Bmin : Minimum brightness

Note (3) Definition of Response time : Sum of Tr, Tf

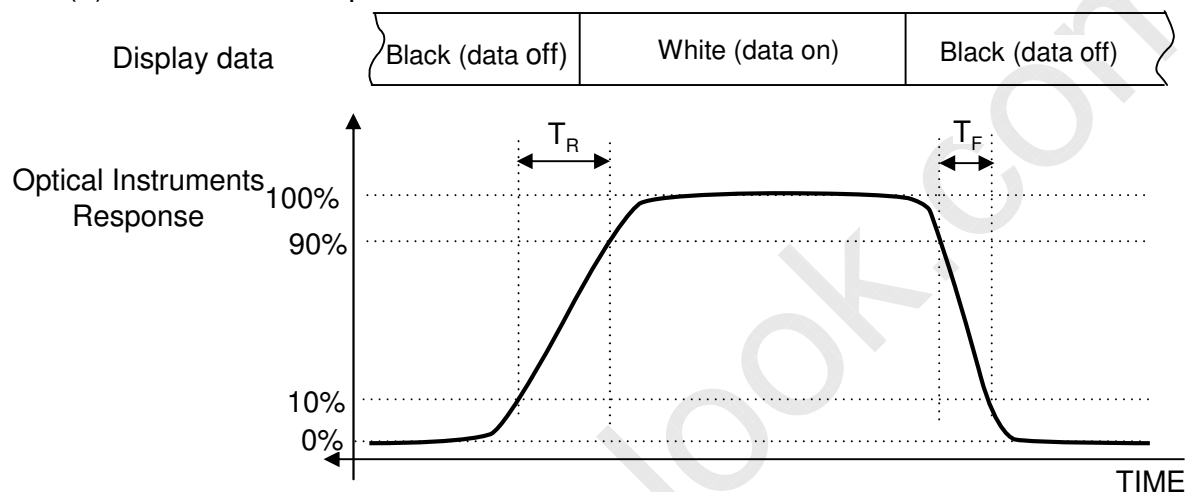

Note (4) Definition of Luminance of White : Luminance of white at center point ⑤

Note (5) Definition of Color Chromaticity (CIE 1931)

Color coordinate of Red, Green, Blue & White at center point ⑤

Note (6) Definition of Viewing Angle

: Viewing angle range (C/R ≥ 10)

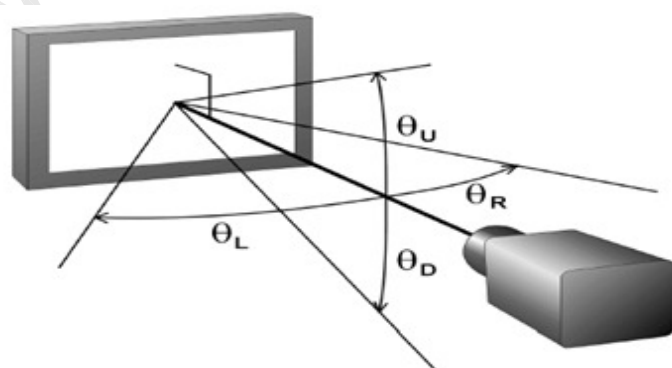

MODEL

LTA550HJ05

Doc. No

06-000-G-091231

Page

7 / 25

3. Electrical Characteristics

Samsung Secret

3.1 TFT LCD Module

The connector for display data & timing signal should be connected.

$T_a = 25^\circ\text{C} \pm 2^\circ\text{C}$

Item	Symbol	Min.	Typ.	Max.	Unit	Note
Voltage of Power Supply	V_{DD}	10.8	12.0	13.2	V	(1)
Current of Power Supply	(a) Black	-	TBD	TBD	mA	(2),(3)
	(b) White	-	TBD	TBD	mA	
	(c) H-STRIPE	-	TBD	TBD	mA	
Vsync Frequency	f_V	-	120.0	-	Hz	
Hsync Frequency	f_H	-	135.0	-	kHz	
Main Frequency	f_{DCLK}	-	297.0	-	MHz	
Rush Current	I_{RUSH}	-	-	7	A	(4)

Note (1) The ripple voltage should be controlled under 10% of V_{DD} .

(2) $f_V=120\text{Hz}$, $f_{DCLK} = 297.0\text{MHz}$, $V_{DD} = 12.0\text{V}$, DC Current.

(3) Power dissipation check pattern (LCD Module only)

a) Black Pattern

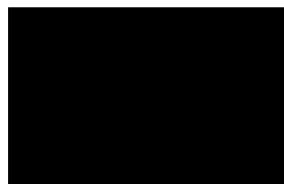

b) White Pattern



c) H-STRIPE

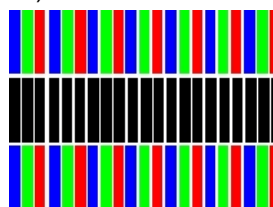

(4) Measurement Conditions

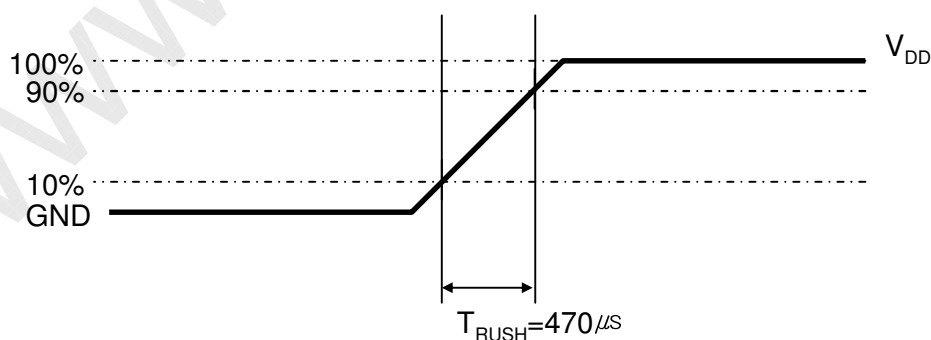

Rush Current I_{RUSH} can be measured when T_{RUSH} is $470 \mu\text{s}$.

MODEL

LTA550HJ05

Doc. No

06-000-G-091231

Page

8 / 25

Samsung Secret

3.2 Back Light Unit

The back light unit contains Edge type White LEDs (Light Emitting Diode)

$T_a = 25 \pm 2^\circ\text{C}$

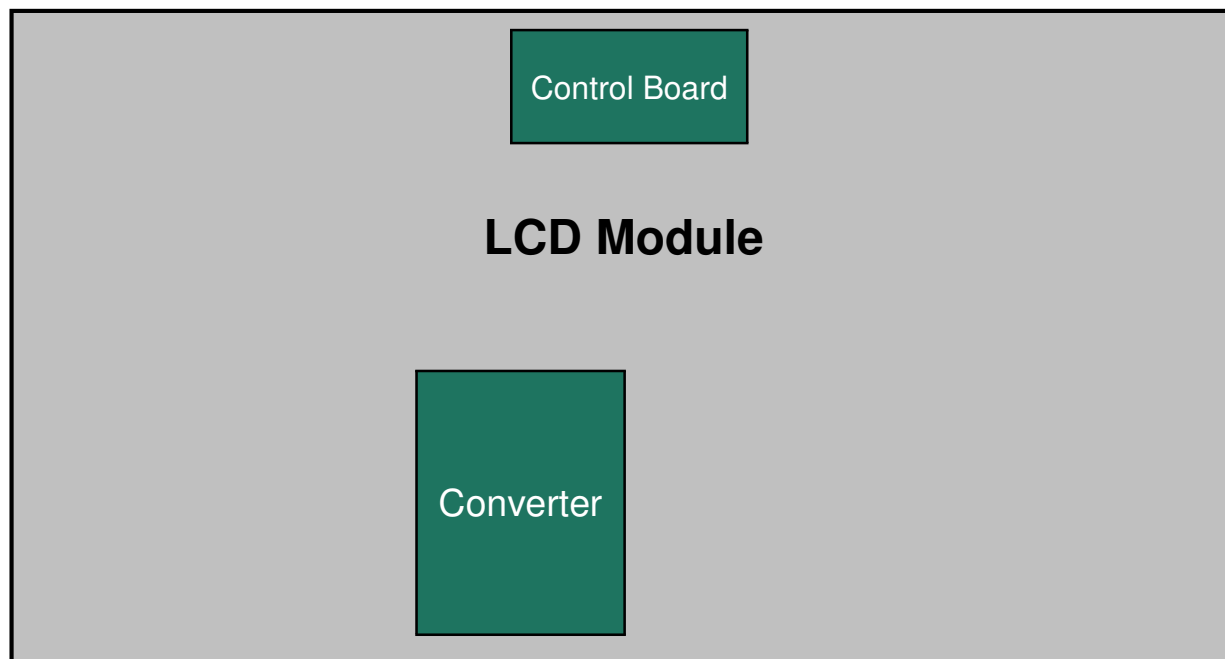

Item	Symbol	Min.	Typ.	Max.	Unit	Note
Operating Life Time	Hr	30,000	-	-	Hour	(1)

Note (1) It is defined as the time to take until the brightness reduces to 50% of its original value.

[Operating condition : $T_a = 25 \pm 2^\circ\text{C}$, For single lamp only.]

MODEL	LTA550HJ05	Doc. No	06-000-G-091231	Page	9 / 25
-------	------------	---------	-----------------	------	--------

3.3 Inverter Input Condition & Specification

Samsung Secret

Items	Symbol	Conditions	Specifications			Unit	Note
			Min.	Typ.	Max.		
Input Voltage	V _{in}	-	22	24	26	V	Ta=25±2 °C
Input Current	I _{RUSH}	V _{in} =24.0V V _{dim} =3.3V	-	-	8.83	A	
Output Current	I _{O,MAX}	V _{in} =24.0V V _{dim} =3.3 V	TBD	TBD	TBD	mArms	
Shut Down Time	T _{SD}	V _{in} =22.0~26.0V V _{dim} =0~3.3 V	-	-	2000	msec	
Backlight On/Off	ON	V _{in} =24.0 V	2.4	-	5.5	V	
	OFF	V _{in} =24.0 V	0	-	0.8		
Dimming Range	V _{-DIM}	V _{in} =22.0~26.0V	0	-	3.3	V	
Dimming Duty Output	D max	V _{in} =24.0V V _{dim} =3.3 V	100	-	-	%	(2)
	D min	V _{in} =24.0V V _{dim} =0 V	-	0	-		
Dimming Frequency	F _{PWM}	V _{in} =24.0V	TBD	TBD	TBD	HZ	
External Dimming Duty Range	EX_Dim	Min	0	-	100	%	(2)
External Dimming Frequency Range	F _{EX_PWM}	V _{in} =22.0~26.0V	TBD	-	TBD	Hz	Dim Pin(#13) :Floating
External Dimming Signal Level	V _{PWM}	High (ON)	2.4	-	5.5	V	
		Low (OFF)	-0.3	-	0.8		

Note) Power Consumption is measured when 450 [cd/m] of luminance which is the typical luminance.

(1) All data is measured after 120min warm-up

(2) Duty = On/(On+Off) * 100

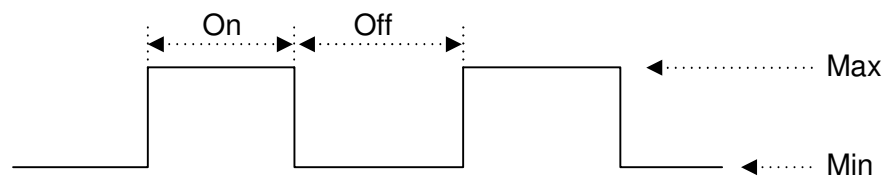

MODEL

LTA550HJ05

Doc. No

06-000-G-091231

Page

10 / 25

4. Input Terminal Pin Assignment

Samsung Secret

4.1.1 Input Signal & Power

Connector : FI-RE51S-HF (JAE/UJU)

Pin	Description	Pin	Description
1	Vdd(12V)	26	Rx4[0]P
2	Vdd(12V)	27	Rx4[1]N
3	Vdd(12V)	28	Rx4[1]P
4	Vdd(12V)	29	Rx4[2]N
5	Vdd(12V)	30	Rx4[2]P
6	No Connection	31	GND
7	GND	32	Rx4CLK-
8	GND	33	Rx4CLK+
9	GND	34	GND
10	Rx2[0]N	35	Rx4[3]N
11	Rx2[0]P	36	Rx4[3]P
12	Rx2[1]N	37	Rx4[4]N
13	Rx2[1]P	38	Rx4[4]P
14	Rx2[2]N	39	GND
15	Rx2[2]P	40	No Connection
16	GND	41	No Connection
17	Rx2CLK-	42	3D Enable (input)
18	Rx2CLK+	43	No Connection
19	GND	44	No Connection
20	Rx2[3]N	45	LVDS Option * Note(1)
21	Rx2[3]P	46	I2C_SCL_F
22	Rx2[4]N	47	No Connection
23	Rx2[4]P	48	I2C_SDA_F
24	GND	49	3D sync (output)
25	Rx4[0]N	50	MAIN_CHECK
		51	No Connection *1)

NOTE) No connection : This Pins are only used for SAMSUNG internal using

NOTE1) MAIN_CHECK: High(3.3V) → Use Autoscript

Low(GND) → Not use Autoscript (Customer can control FRC Chip)

MODEL

LTA550HJ05

Doc. No

06-000-G-091231

Page

11 / 25

Note) Pin number starts from Right side

Samsung Secret

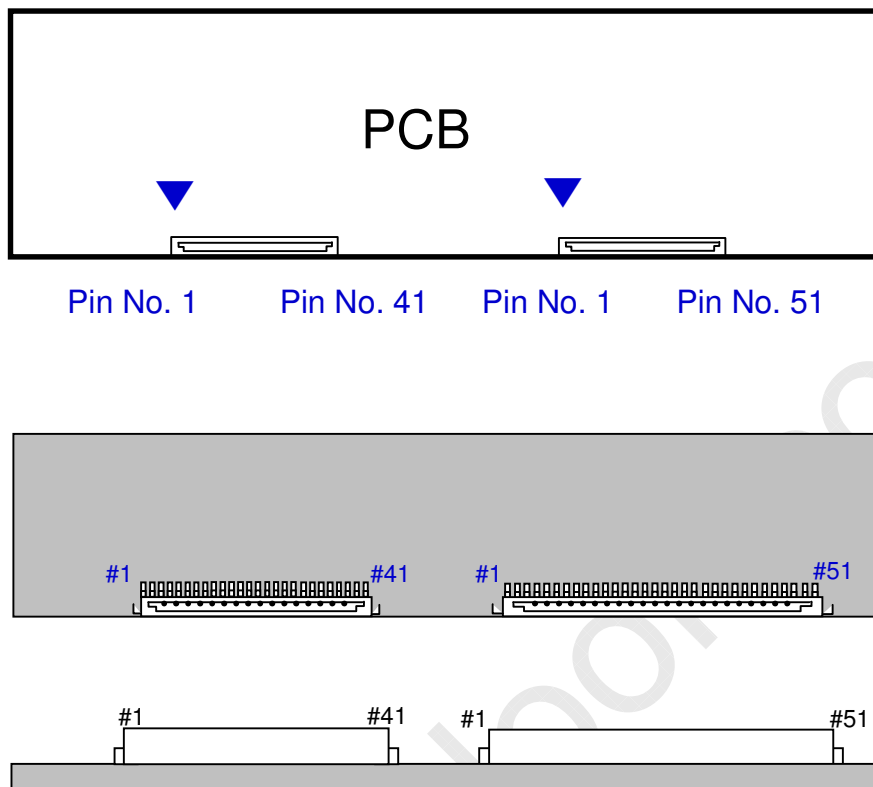

Fig. Connector diagram

- All GND pins should be connected together and also be connected to the LCD's metal chassis.
- All power input pins should be connected together.
- All NC pins should be separated from other signal or power.

Note(2) LVDS OPTION : This model have only JEIDA LVDS format

SEQUENCE : On = VDD(T1) → LVDS Option → Interface Signal(T2)

OFF = Interface Signal(T3) → LVDS Option → VDD

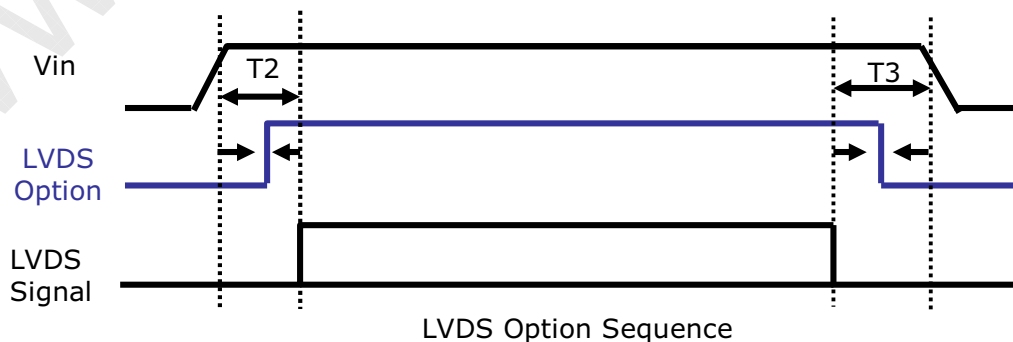

MODEL

LTA550HJ05

Doc. No

06-000-G-091231

Page

12 / 25

4.2. Inverter Input Pin Configuration

Samsung Secret

Connector : Yeon-ho, 20022WR-14B1

Pin No.	Pin Configuration(FUNCTION)
	Master
1	24 V
2	24 V
3	24 V
4	24 V
5	24 V
6	GND
7	GND
8	GND
9	GND
10	GND
11	Error Out
12	Backlight On /Off [ON:2.4 - 5.5 V, OFF: 0 - 0.8 V]
13	Dimming Control [0V:Min, 3.3V:Max] *Note(1)
14	External PWM [0~100%] *Note(1)

Note(1) If use Dimming Control, Pin 14 Must be N.C

If use External PWM, Pin 13 Must be N.C

4.3. Inverter Input Power Sequence

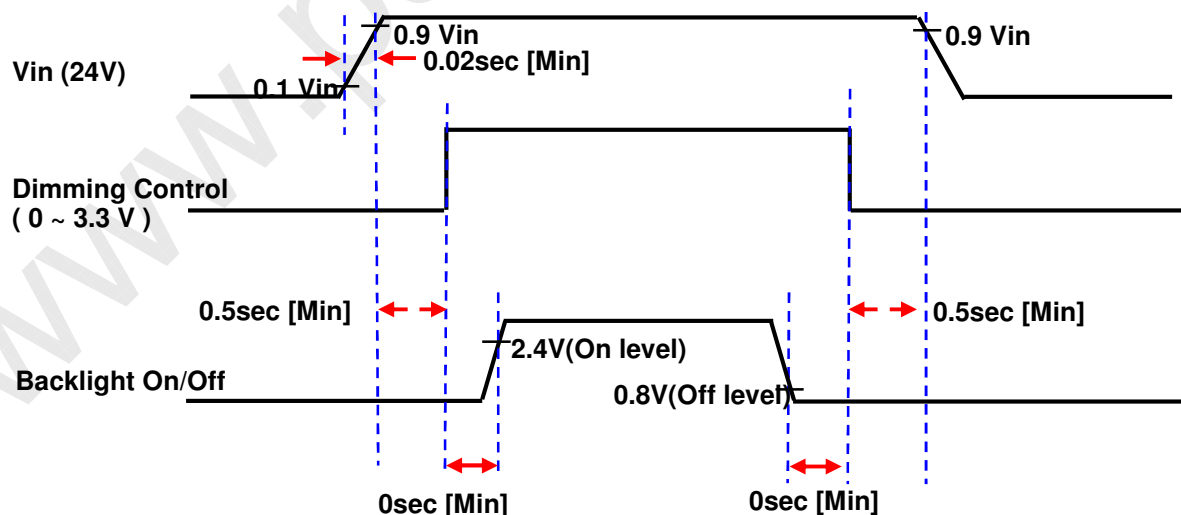

Note) SEQUENCE : ON = Vin(24V) > Dimming Control ≥ Backlight On/Off

OFF = Backlight On/Off ≥ Dimming Control > Vin(24V)

MODEL	LTA550HJ05	Doc. No	06-000-G-091231	Page	13 / 25
-------	------------	---------	-----------------	------	---------

4.4 LVDS Interface

Samsung Secret

- LVDS Receiver : Tcon (merged)
- Data Format (JEIDA & Normal)

	LVDS pin	JEIDA -DATA
TxOUT/RxIN0	TxIN/RxOUT0	R4
	TxIN/RxOUT1	R5
	TxIN/RxOUT2	R6
	TxIN/RxOUT3	R7
	TxIN/RxOUT4	R8
	TxIN/RxOUT6	R9
	TxIN/RxOUT7	G4
TxOUT/RxIN1	TxIN/RxOUT8	G5
	TxIN/RxOUT9	G6
	TxIN/RxOUT12	G7
	TxIN/RxOUT13	G8
	TxIN/RxOUT14	G9
	TxIN/RxOUT15	B4
	TxIN/RxOUT18	B5
TxOUT/RxIN2	TxIN/RxOUT19	B6
	TxIN/RxOUT20	B7
	TxIN/RxOUT21	B8
	TxIN/RxOUT22	B9
	TxIN/RxOUT24	HSYNC
	TxIN/RxOUT25	VSYNC
	TxIN/RxOUT26	DEN
TxOUT/RxIN3	TxIN/RxOUT27	R2
	TxIN/RxOUT5	R3
	TxIN/RxOUT10	G2
	TxIN/RxOUT11	G3
	TxIN/RxOUT16	B2
	TxIN/RxOUT17	B3
	TxIN/RxOUT23	RESERVED
TxOUT/RxIN4	TxIN/RxOUT28	R0
	TxIN/RxOUT29	R1
	TxIN/RxOUT30	G0
	TxIN/RxOUT31	G1
	TxIN/RxOUT32	B0
	TxIN/RxOUT33	B1
	TxIN/RxOUT34	RESERVED

MODEL

LTA550HJ05

Doc. No

06-000-G-091231

Page

14 / 25

Samsung Secret

4.5 Input Signals, Basic Display Colors and Gray Scale of Each Color

COLOR	DISPLAY (8bit)	DATA SIGNAL																												GRAY SCALE LEVEL	
		RED									GREEN									BLUE											
		R0	R1	R2	R3	R4	R5	R6	R7	R8	R9	G0	G1	G2	G3	G4	G5	G6	G7	G8	G9	B0	B1	B2	B3	B4	B5	B6	B7		B8
BASIC COLOR	BLACK	0	0	0	0	0	0	0	0	0	0	0	0	0	0	0	0	0	0	0	0	0	0	0	0	0	0	0	0	-	
	BLUE	0	0	0	0	0	0	0	0	0	0	0	0	0	0	0	0	0	0	0	0	1	1	1	1	1	1	1	1	1	-
	GREEN	0	0	0	0	0	0	0	0	0	0	1	1	1	1	1	1	1	1	1	1	0	0	0	0	0	0	0	0	0	-
	CYAN	0	0	0	0	0	0	0	0	0	0	1	1	1	1	1	1	1	1	1	1	1	1	1	1	1	1	1	1	1	-
	RED	1	1	1	1	1	1	1	1	1	1	0	0	0	0	0	0	0	0	0	0	0	0	0	0	0	0	0	0	0	-
	MAGENTA	1	1	1	1	1	1	1	1	1	1	0	0	0	0	0	0	0	0	0	0	1	1	1	1	1	1	1	1	1	-
	YELLOW	1	1	1	1	1	1	1	1	1	1	1	1	1	1	1	1	1	1	1	1	0	0	0	0	0	0	0	0	0	-
	WHITE	1	1	1	1	1	1	1	1	1	1	1	1	1	1	1	1	1	1	1	1	1	1	1	1	1	1	1	1	1	-
GRAY SCALE OF RED	BLACK	0	0	0	0	0	0	0	0	0	0	0	0	0	0	0	0	0	0	0	0	0	0	0	0	0	0	0	0	R0	
	DARK ↑	1	0	0	0	0	0	0	0	0	0	0	0	0	0	0	0	0	0	0	0	0	0	0	0	0	0	0	0	R1	
		0	1	0	0	0	0	0	0	0	0	0	0	0	0	0	0	0	0	0	0	0	0	0	0	0	0	0	0	R2	
		:	:	:	:	:	:	:	:	:	:	:	:	:	:	:	:	:	:	:	:	:	:	:	:	:	:	:	:	R3~R1020	
	LIGHT ↓	:	:	:	:	:	:	:	:	:	:	:	:	:	:	:	:	:	:	:	:	:	:	:	:	:	:	:	:	:	
		1	0	1	1	1	1	1	1	1	1	0	0	0	0	0	0	0	0	0	0	0	0	0	0	0	0	0	0	R1021	
		0	1	1	1	1	1	1	1	1	1	0	0	0	0	0	0	0	0	0	0	0	0	0	0	0	0	0	0	R1022	
	RED	1	1	1	1	1	1	1	1	1	1	0	0	0	0	0	0	0	0	0	0	0	0	0	0	0	0	0	0	R1023	
GRAY SCALE OF GREEN	BLACK	0	0	0	0	0	0	0	0	0	0	0	0	0	0	0	0	0	0	0	0	0	0	0	0	0	0	0	0	G0	
	DARK ↑	0	0	0	0	0	0	0	0	0	0	1	0	0	0	0	0	0	0	0	0	0	0	0	0	0	0	0	0	G1	
		0	0	0	0	0	0	0	0	0	0	0	1	0	0	0	0	0	0	0	0	0	0	0	0	0	0	0	0	G2	
		:	:	:	:	:	:	:	:	:	:	:	:	:	:	:	:	:	:	:	:	:	:	:	:	:	:	:	:	G3~G1020	
	LIGHT ↓	:	:	:	:	:	:	:	:	:	:	:	:	:	:	:	:	:	:	:	:	:	:	:	:	:	:	:	:	:	
		0	0	0	0	0	0	0	0	0	0	1	0	1	1	1	1	1	1	1	1	0	0	0	0	0	0	0	0	G1021	
		0	0	0	0	0	0	0	0	0	0	1	1	1	1	1	1	1	1	1	1	0	0	0	0	0	0	0	0	G1022	
	GREEN	0	0	0	0	0	0	0	0	0	0	1	1	1	1	1	1	1	1	1	1	0	0	0	0	0	0	0	0	G1023	
GRAY SCALE OF BLUE	BLACK	0	0	0	0	0	0	0	0	0	0	0	0	0	0	0	0	0	0	0	0	0	0	0	0	0	0	0	B0		
	DARK ↑	0	0	0	0	0	0	0	0	0	0	0	0	0	0	0	0	0	0	0	0	1	0	0	0	0	0	0	0	B1	
		0	0	0	0	0	0	0	0	0	0	0	0	0	0	0	0	0	0	0	0	0	1	0	0	0	0	0	0	B2	
		:	:	:	:	:	:	:	:	:	:	:	:	:	:	:	:	:	:	:	:	:	:	:	:	:	:	:	:	B3~B1020	
	LIGHT ↓	:	:	:	:	:	:	:	:	:	:	:	:	:	:	:	:	:	:	:	:	:	:	:	:	:	:	:	:	:	
		0	0	0	0	0	0	0	0	0	0	0	0	0	0	0	0	0	0	0	0	1	0	1	1	1	1	1	1	B1021	
		0	0	0	0	0	0	0	0	0	0	0	0	0	0	0	0	0	0	0	0	1	1	1	1	1	1	1	1	B1022	
	BLUE	0	0	0	0	0	0	0	0	0	0	0	0	0	0	0	0	0	0	0	0	1	1	1	1	1	1	1	1	B1023	

Note) Definition of Gray :

Rn : Red Gray, Gn : Green Gray, Bn : Blue Gray (n = Gray level)

Input Signal : 0 = Low level voltage, 1 = High level voltage

MODEL	LTA550HJ05	Doc. No	06-000-G-091231	Page	15 / 25
-------	------------	---------	-----------------	------	---------

Samsung Secret

5. Interface Timing

5.1 Timing Parameters (DE mode)

SIGNAL	ITEM	SYMBOL	Video	PAL	NTSC	Unit	NOTE
Clock	Frequency	$1/T_C$	142.5	148.5	148.5	MHz	-
Hsync		F_H	64.8	67.5	140	KHz	-
Vsync		F_V	48	50	60	Hz	-
Vertical Display Term	Active Display Period	T_{VD}	1080	1080	1080	Lines	-
	Vertical Total	T_V	1350	1350	1125	Lines	-
Horizontal Display Term	Active Display Period	T_{HD}	1920	1920	1920	Clock s	-
	Horizontal Total	T_H	2200 (1100*2)	2200 (1100*2)	2200 (1100*2)	clocks	-

Note) This product is DE mode. But the Hsync & Vsync signal must be inputted

- (1) Test Point : TTL control signal and CLK at LVDS Tx input terminal in system
- (2) Internal VDD = 3.3V
- (3) Spread Spectrum
 - Modulation rate (Max) : +-1.5%
 - Modulation frequency : under 100Khz

MODEL

LTA550HJ05

Doc. No

06-000-G-091231

Page

16 / 25

5.2 Timing diagrams of interface signal (DE mode)

Samsung Secret

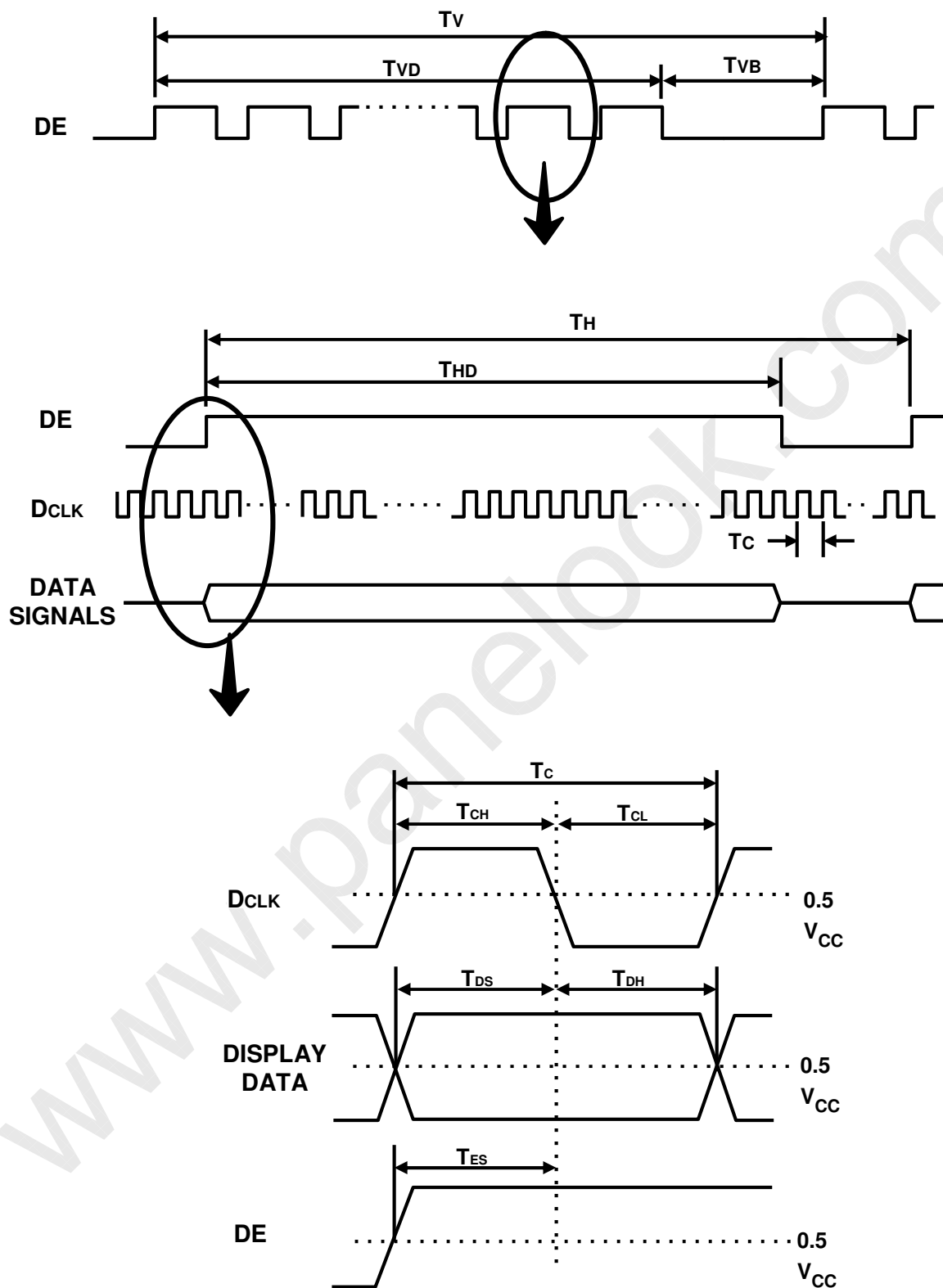

MODEL

LTA550HJ05

Doc. No

06-000-G-091231

Page

17 / 25

5.3 Power ON/OFF Sequence

Samsung Secret

To prevent a latch-up or DC operation of the LCD Module, the power on/off sequence should be as the diagram below.

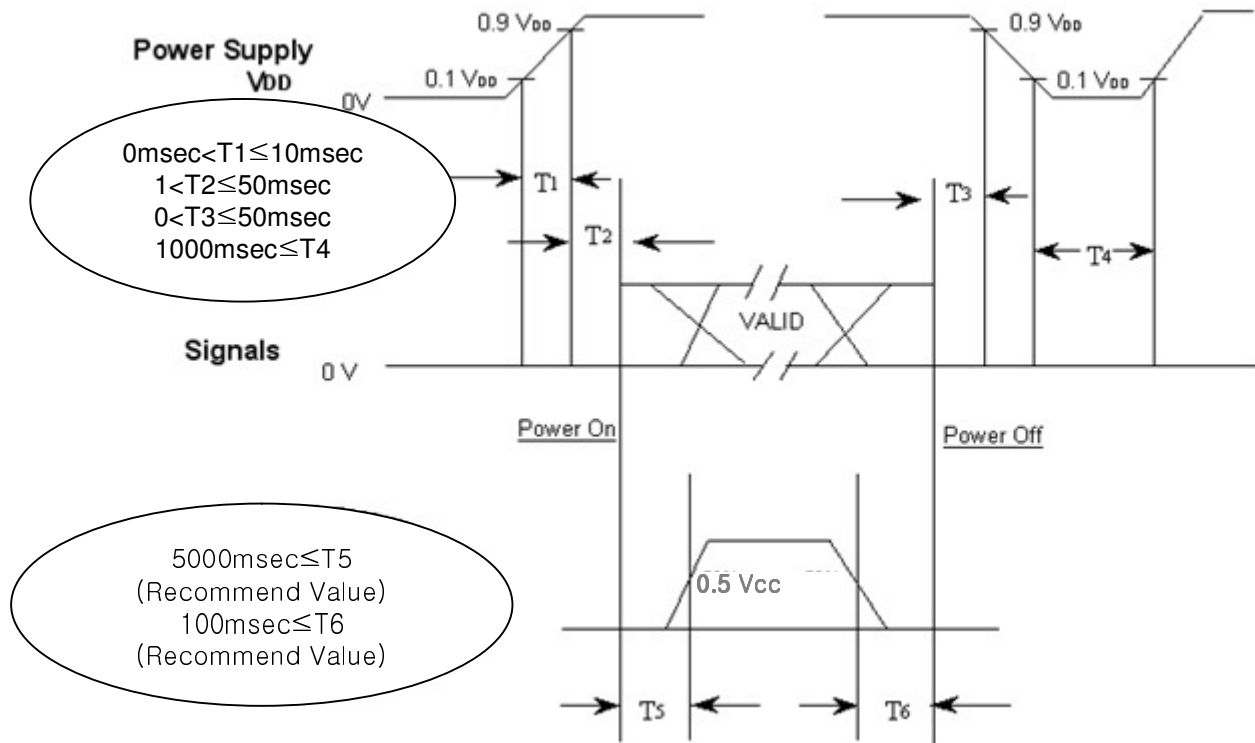

T_1 : V_{DD} rising time from 10% to 90%

T_2 : The time from V_{DD} to valid data at power ON.

T_3 : The time from valid data off to V_{DD} off at power Off.

T_4 : V_{DD} off for Windows restart

T_5 : The time from valid data to B/L enable at power ON.

T_6 : The time from valid data off to B/L disable at power Off.

- The supply voltage of the external system for the Module input should be the same as the definition of V_{DD} .
- Apply the lamp voltage within the LCD operation range. When the back light turns on before the LCD operation or the LCD turns off before the back light turns off, the display may momentarily show abnormal screen.
- In case of V_{DD} = off level, please keep the level of input signals low or keep a high impedance.
- T_4 should be measured after the Module has been fully discharged between power off and on period.
- Interface signal should not be kept at high impedance when the power is on.
- In Case T_5 is less than 1000msec and T_6 is less than 100msec, Garbage Display can be seen. (It is not related to electrical function issue, Just for recommendation to prevent Garbage Display)

MODEL

LTA550HJ05

Doc. No

06-000-G-091231

Page

18 / 25



6. Outline Dimension- Front

Samsung Secret

TBD

www.panelook.com

MODEL	LTA550HJ05	Doc. No	06-000-G-091231	Page	19 / 25
-------	------------	---------	-----------------	------	---------

6. Outline Dimension- Rear

Samsung Secret

TBD

MODEL

LTA550HJ05

Doc. No

06-000-G-091231

Page

20 / 25

Samsung Secret

7. PACKING

7.1 CARTON (Internal Package)

(1) Packing Form

Corrugated fiberboard box and corrugated cardboard as shock absorber

(2) Packing Method

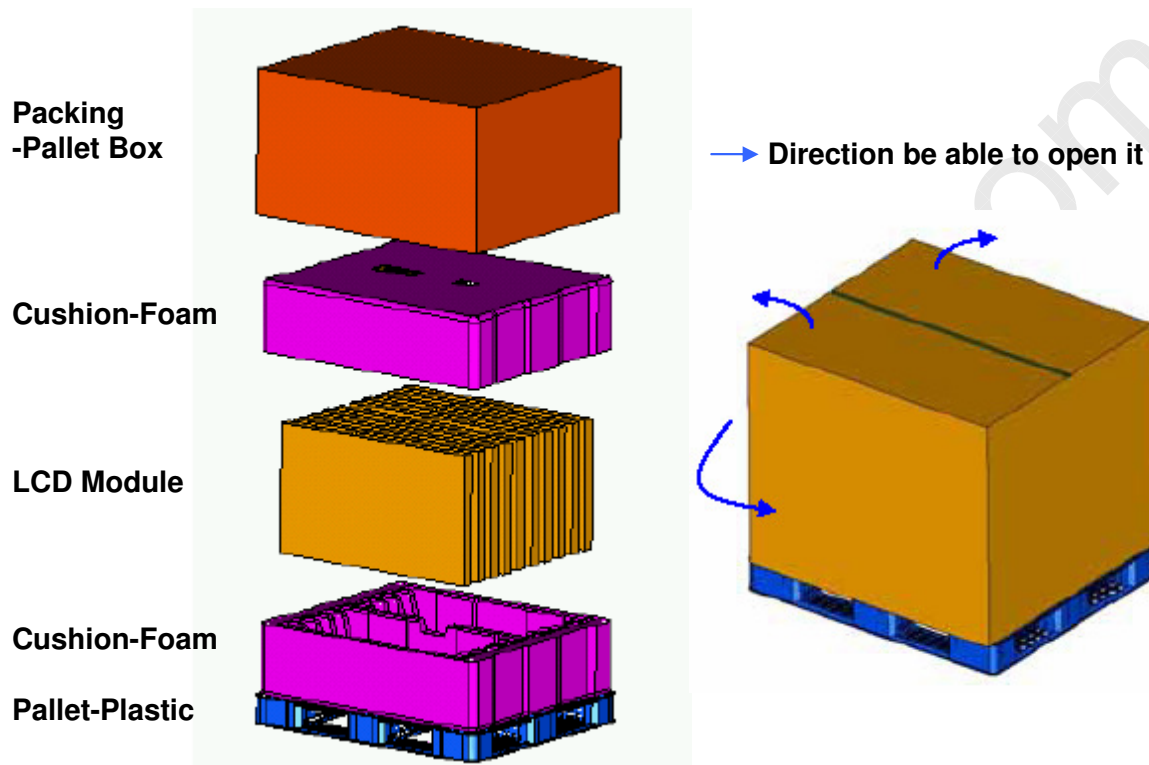

7.2 Packing Specification

Item	Specification	Remark
LCD Packing	12ea / (Packing-Pallet Box)	1. TBD kg / LCD (12ea) 2. 15.3 Kg / Cushion-pallet (2ea) 3. 10.5 Kg / Packing-Pallet Box (1ea) 4. Cushion-pallet Material : EPS 5. Packing-Pallet Box Material : DW4
Pallet	1Box / Pallet	1. Pallet weight = 10 kg
Packing Direction	Vertical	
Total Pallet Size	H x V x height	1475mm(H) x 1150mm(V) x 995mm(height)
Total Pallet Weight	TBD kg	Pallet(10 kg) + Module (TBD kg) + Cushion (up + bottom =15.3kg) + Pallet-BOX(10.5kg)

MODEL

LTA550HJ05

Doc. No

06-000-G-091231

Page

21 / 25

Samsung Secret

8. MARKING & OTHERS

A nameplate bearing followed by is affixed to a shipped product at the specified location on each product.

- (1) Part number : LTA400HF16
- (2) Revision: Three letters
- (3) Lot number : X X X X XXX XX X

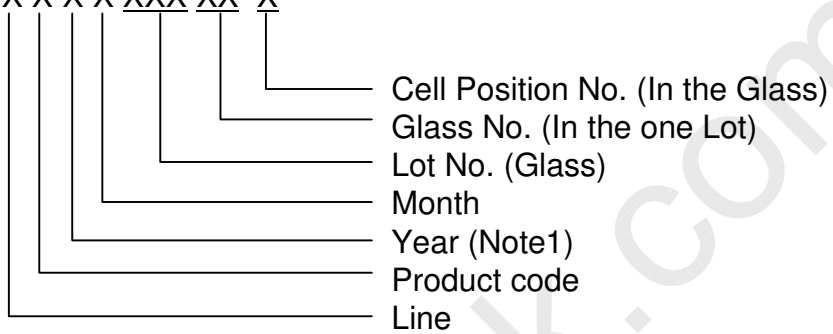

(4) Nameplate Indication

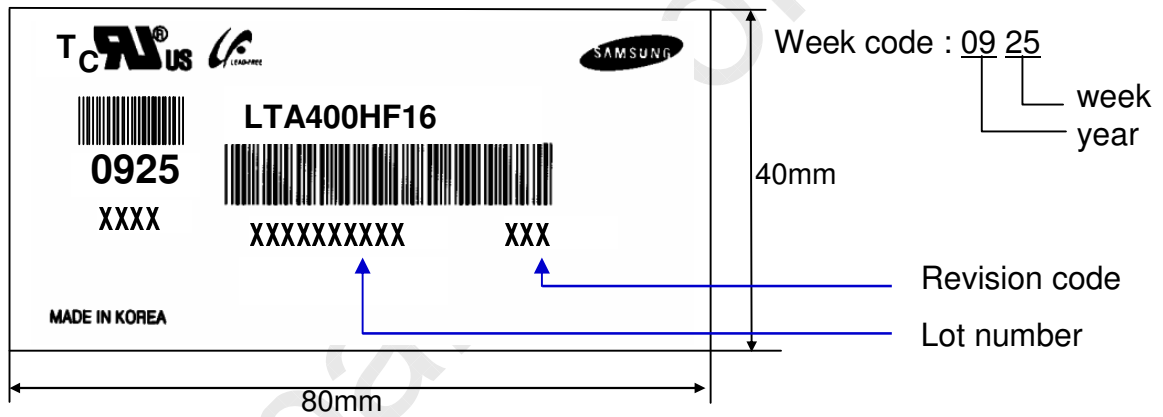

(5) Packing box attach

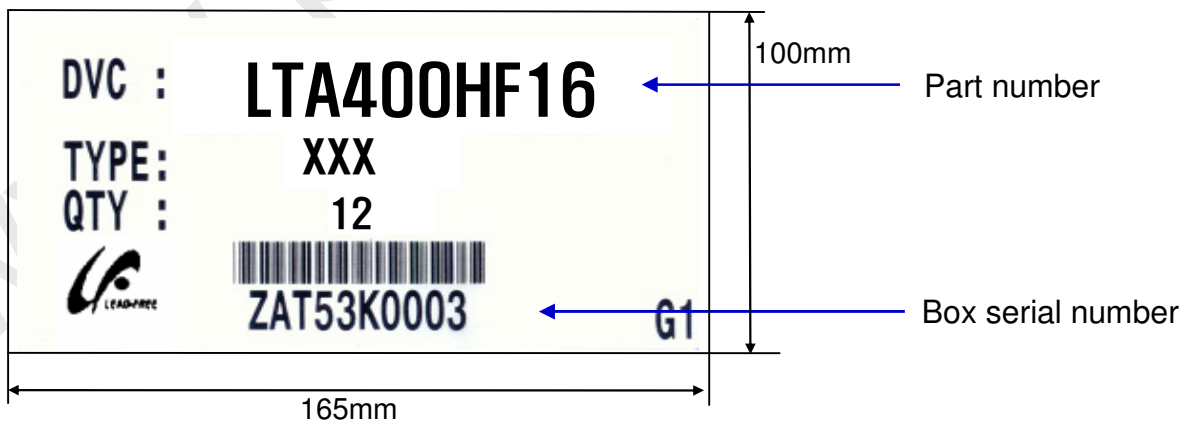

(6) Others

- 1. After service part

Lamps cannot be replaced because of the narrow bezel structure.

MODEL	LTA550HJ05	Doc. No	06-000-G-091231	Page	22 / 25
-------	------------	---------	-----------------	------	---------

9. General Precautions

Samsung Secret

9.1 Handling

- (a) When the Module is assembled, it should be attached to the system firmly using all mounting holes. Be careful not to twist and bend the Module.
- (b) Because the inverter use high voltage, it should be disconnected from power before it is assembled or disassembled.
- (c) Refrain from strong mechanical shock and / or any force to the Module.
In addition to damage, this may cause improper operation or damage to the Module and CCFT back light.
- (d) Note that polarizers are very fragile and could be damage easily.
Do not press or scratch the surface harder than a HB pencil lead.
- (e) Wipe off water droplets or oil immediately. If you leave the droplets for a long time, staining or discoloration may occur.
- (f) If the surface of the polarizer is dirty, clean it using absorbent cotton or soft cloth.
- (g) Desirable cleaners are water, IPA(Isopropyl Alcohol) or Hexane.
Do not use Ketone type materials(ex. Acetone), Ethyl alcohol, Toluene, Ethyl acid or Methyl chloride. It might permanent damage to the polarizer due to chemical reaction.
- (h) If the liquid crystal material leaks from the panel, it should be kept away from the eyes or mouth . In case of contact with hands, legs or clothes, it must be washed away with soap thoroughly.
- (i) Protect the module from Electrostatic discharge. Otherwise the ASIC IC or semiconductor would be damaged.
- (j) Use finger-stalls with soft gloves in order to keep display clean during the incoming inspection and assembly process.
- (k) Do not disassemble the Module.
- (l) Do not disassemble shield case of inverter & LVDS board
- (m) Do not connect N.C pins. (Samsung internal use only)
- (n) Protection film for polarizer on the Module should be slowly peeled off just before use so that the electrostatic charge can be minimized. Must put on antistatic glove while handling a module
- (o) Pins of I/F connector should not be touched directly with bare hands.

MODEL	LTA550HJ05	Doc. No	06-000-G-091231	Page	23 / 25
-------	------------	---------	-----------------	------	---------

Samsung Secret

9.2 Storage

- (a) Do not leave the Module in high temperature, and high humidity for a long time. It is highly recommended to store the Module with temperature from 0 to 35 °C and relative humidity of less than 70%.
- (b) Do not store the TFT-LCD Module in direct sunlight.
- (c) The Module should be stored in a dark place. It is prohibited to apply sunlight or fluorescent light in storing.

9.3 Operation

- (a) Do not connect or disconnect the Module in the "Power On" condition.
- (b) Power supply should always be turned on/off by the "Power on/off sequence"
- (c) Module has high frequency circuits. Sufficient suppression to the electromagnetic interference should be done by system manufacturers. Grounding and shielding methods may be important to minimize the interference.
- (d) The cable between the back light connector and its inverter power supply should be connected directly with a minimized length. A longer cable between the back light and the inverter may cause lower luminance of lamp(CCFT) and may require higher startup voltage(Vs).

9.4 Operation Condition Guide

- (a) The LCD product should be operated under normal conditions.
Normal condition is defined as below;
 - Temperature : 20 ± 15 °C
 - Humidity : 55 ± 20 %
 - Display pattern : continually changing pattern (Not stationary)
- (b) If the product will be used in extreme conditions such as high temperature, humidity, display patterns or operation time etc., It is strongly recommended to contact SEC for Application engineering advice. Otherwise, its reliability and function may not be guaranteed. Extreme conditions are commonly found at Airports, Transit Stations, Banks, Stock market, and Controlling systems.

MODEL

LTA550HJ05

Doc. No

06-000-G-091231

Page

24 / 25

9.5 Others

Samsung Secret

- (a) Ultra-violet ray filter is necessary for outdoor operation.
- (b) Avoid condensation of water. It may result in improper operation or disconnection of electrode.
- (c) Do not exceed the absolute maximum rating value. (supply voltage variation, input voltage variation, variation in part contents and environmental temperature, and so on)
Otherwise the Module may be damaged.
- (d) If the Module keeps displaying the same pattern for a long period of time, the image may be "sticked" to the screen.
To avoid image sticking, it is recommended to use a screen saver.
- (e) This Module has its circuitry PCB's on the rear side and should be handled carefully in order not to be stressed.
- (f) Please contact SEC in advance when you display the same pattern for a long time.

MODEL

LTA550HJ05

Doc. No

06-000-G-091231

Page

25 / 25